

brother®

BASIC USER'S GUIDE

DCP-9055CDN

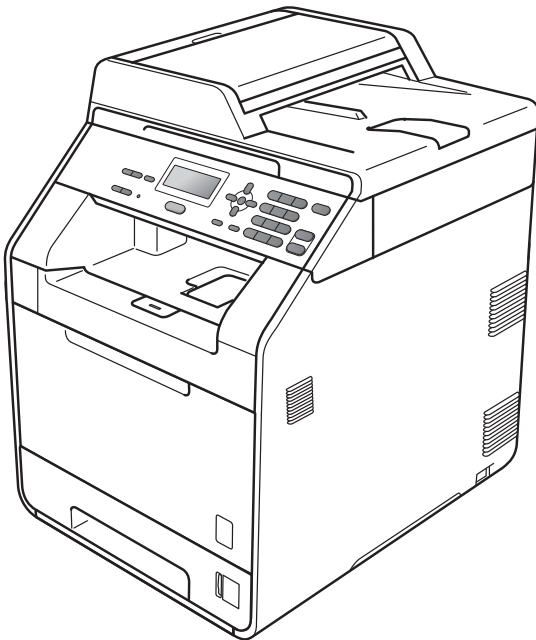

Version A

CHN-ENG

To create a better environment

Please cooperate

Firstly, thank you very much indeed for using our Brother products!

Brother focuses on the earth environment concerned. And make a basic policy which is to concern about the earth environment, including any workflow from product development to discard. The local citizen should be responsible for local society and its environment during these environment protection activities.

Therefore, we hope you'll take part in this environment plan, and pay attention to environment protection points as below while discarding used consumables.

- 1 Please deliver the used package materials to relevant waste disposal office for recycle.
- 2 When you discard used consumables, please follow and carry on relevant local regulations properly.
- 3 When the machine need replacing parts for the maintenance and repair, please discard used circuit boards, used electrical parts and products as disposed electrical materials.
- 4 The power consumption is 0 W after you turn off the machine and unplug it from the AC outlet.
- 5 Some parts in the machine can be used on the same series model machines which produced by the same factory.

Note: If you want to replace the parts, please contact your local Brother repair station.

User's Guides and where do I find it?

Which manual?	What's in it?	Where is it?
Safety and Legal	Please read the Safety Instructions before you set up your machine.	Printed / In the box
Quick Setup Guide	Read this Guide first. Follow the instructions for setting up your machine and installing the drivers and software for the operating system and connection type you are using.	For Chinese: Printed / In the box For Chinese English: PDF file / Documentation CD-ROM / In the box
Basic User's Guide	Learn the basic Copy and Scan operations and how to replace consumables. See troubleshooting tips.	For Chinese: Printed / In the box For Chinese English: PDF file / Documentation CD-ROM / In the box
Advanced User's Guide	Learn more advanced operations: Copy, security features and performing routine maintenance.	PDF file / Documentation CD-ROM / In the box
Software User's Guide	Follow these instructions for Printing, Scanning, Network Scanning and using the Brother ControlCenter utility.	PDF file / Documentation CD-ROM / In the box
Network Glossary	This Guide provides basic information about advanced network features of Brother machines along with general networking and common terms.	PDF file / Documentation CD-ROM / In the box
Network User's Guide	This Guide provides useful information of wired network settings and security settings using Brother machine. You can also find supported protocol information for your machine and the detailed troubleshooting tips.	PDF file / Documentation CD-ROM / In the box

Table of Contents

(BASIC USER'S GUIDE)

1	General information	1
	Using the documentation	1
	Symbols and conventions used in the documentation	1
	Accessing the Advanced User's Guide, Software User's Guide and Network User's Guide	2
	Viewing Documentation	2
	Accessing Brother Support (Windows®)	4
	Accessing Brother Support (Macintosh)	4
	Control panel overview	6
	Data LED indications	8
	Volume settings	9
	Beeper volume	9
2	Loading paper	10
	Loading paper and print media	10
	Loading paper in the standard paper tray	10
	Loading paper in the multi-purpose tray (MP tray)	12
	Scannable area	16
	Unprintable area when printing from a computer	17
	Paper settings	18
	Paper Type	18
	Paper Size	18
	Tray Use in copy mode	18
	Tray Use in print mode	19
	Acceptable paper and other print media	19
	Recommended paper and print media	19
	Type and size of paper	19
	Handling and using special paper	21
3	Loading documents	24
	How to load documents	24
	Using the automatic document feeder (ADF)	24
	Using the scanner glass	25
4	Making copies	26
	How to copy	26
	Stop copying	26
	Copy settings	26
5	How to print from a computer	27
	Printing a document	27

6	How to scan to a computer	28
	Scanning a document as PDF file using ControlCenter4 (Windows®)	28
	Changing the SCAN key settings	31
	Before scanning.....	31
	SCAN key settings.....	31
	Scanning using the SCAN key	33
A	Routine maintenance	34
	Replacing the consumable items.....	34
	Replacing a Toner cartridge	37
	Replacing the drum unit.....	43
	Replacing the belt unit	49
	Replacing the waste toner box	54
	Cleaning and Checking the machine	60
	Cleaning the outside of the machine	60
	Cleaning the scanner glass	61
	Cleaning the laser scanner windows	62
	Cleaning the corona wires	66
	Cleaning the drum unit	69
	Cleaning the paper pick-up rollers.....	75
	Calibration	76
	Auto Registration	77
	Manual Registration.....	77
	Frequency (Color Correction).....	77
B	Troubleshooting	78
	Error and maintenance messages.....	78
	Document is jammed in the top of the ADF unit	83
	Document is jammed under the document cover	83
	Removing small documents jammed in the ADF.....	84
	Document is jammed at the output tray	84
	Paper is jammed in the MP tray	84
	Paper is jammed in the Paper Tray 1 or Tray 2.....	85
	Paper is jammed at the back of the machine	86
	Paper is jammed inside the machine.....	88
	Paper is jammed underneath paper tray 1	91
	Troubleshooting.....	93
	If you are having difficulty with your machine	93
	Improving the print quality	97
	Machine Information	104
	Checking the Serial Number.....	104
	Reset functions.....	104
	How to reset the machine.....	104
C	Menu and features	105
	On-screen programming.....	105
	How to access the menu mode	105
	Menu table	106
	Entering text	116

D Specifications 118

General 118
Document Size 120
Print media..... 121
Copy 123
Scanner 124
Printer 125
Interfaces 126
Computer requirements 127
Consumable items 129
Network (LAN) 130

E Index 131

Table of Contents

(ADVANCED USER'S GUIDE)

The *Advanced User's Guide* explains the following features and operations.

You can view the *Advanced User's Guide* on the Documentation CD-ROM.

1 General setup

Memory storage
Ecology features
LCD Contrast
User Settings List
Network Configuration List

2 Security features

Secure Function Lock 2.0

3 Making copies

Copy settings
Duplex (2-sided) copying

A Routine maintenance

Cleaning and checking the machine
Replacing periodic maintenance parts
Packing and shipping the machine

B Options

Optional paper tray (LT-300CL)
Memory board

C Glossary

D Index

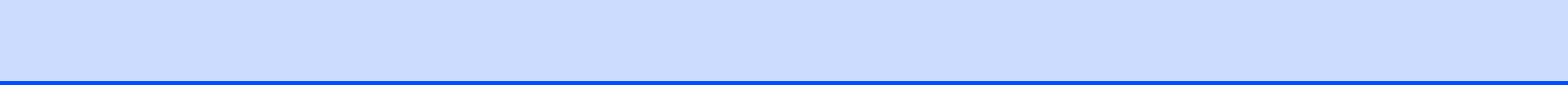

Using the documentation

Thank you for buying a Brother machine! Reading the documentation will help you make the most of your machine.

Symbols and conventions used in the documentation

The following symbols and conventions are used throughout the documentation.

Bold	Bold style identifies keys on the machine control panel or computer screen.
<i>Italics</i>	Italicized style emphasizes an important point or refers you to a related topic.
Courier New	Courier New font identifies the messages shown on the LCD of the machine.

WARNING

WARNING indicates a potentially hazardous situation which, if not avoided, could result in death or serious injuries.

CAUTION

CAUTION indicates a potentially hazardous situation which, if not avoided, may result in minor or moderate injuries.

IMPORTANT

IMPORTANT indicates a potentially hazardous situation which, if not avoided, may result in damage to property or loss of product functionality.

 Electrical Hazard icons alert you to a possible electrical shock.



Hot Surface icons warn you not to touch machine parts that are hot.



Notes tell you how you should respond to a situation that may arise or give tips about how the current operation works with other features.

Accessing the Advanced User's Guide, Software User's Guide and Network User's Guide

This Basic User's Guide does not contain all the information about the machine such as how to use the advanced features Copy, Printer, Scanner and Network. When you are ready to learn detailed information about these operations, read the **Advanced User's Guide**, **Software User's Guide**, **Network Glossary** and **Network User's Guide** that are on the Documentation CD-ROM.

Viewing Documentation

- 1 Turn on your computer. Insert the Documentation CD-ROM into your CD-ROM drive.

 **Note**

(Windows® users) If the screen does not appear automatically, go to **My Computer (Computer)**, double-click the CD-ROM icon, and then double-click **index.html**.

- 2 (Macintosh users) Double-click the Documentation CD-ROM icon, and then double-click **index.html**.

- 3 Click your country.

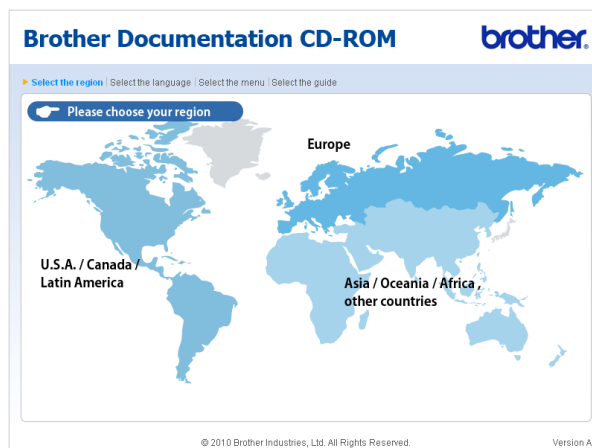

- 4 Point to your language, point to **View Guide**, and then click the guide you want to read.

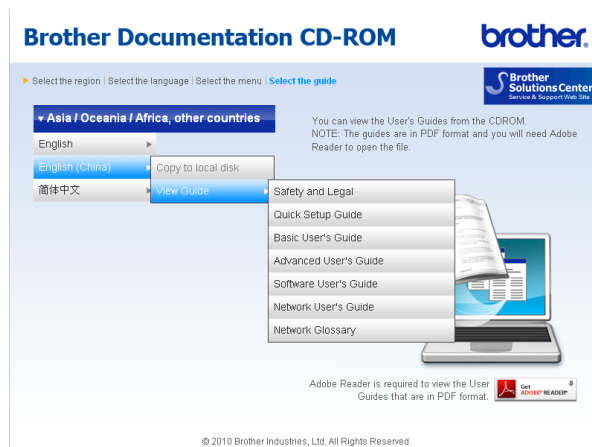
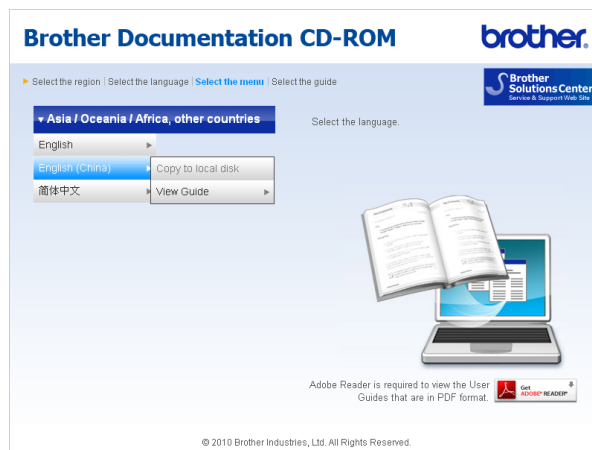

**Note**

- (Windows® users only) Your web browser may display a yellow bar at the top of the page that contains a security warning about Active X controls. For the page to display correctly you must click on the bar, click **Allow Blocked Content**, then click **Yes** in the Security Warning dialog box.
- (Windows® users only) ¹ For faster access, you can copy all user documentation in PDF format to a local folder on your computer. Point to your language, then click **Copy to local disk**.

¹ Microsoft® Internet Explorer® 6.0 or greater.

How to find Scanning instructions

There are several ways you can scan documents. You can find the instructions as follows:

Software User's Guide

- *Scanning*
- *ControlCenter*
- *Network Scanning*

Presto! PageManager User's Guide**Note**

Presto! PageManager must be downloaded and installed before use.

Presto! PageManager User's Guide

- Instructions for scanning directly from Presto! PageManager. The complete Presto! PageManager User's Guide can be viewed from the Help selection in the Presto! PageManager application.

How to find Network setup instructions

Your machine can be connected to a wired network. You can find basic setup instructions in the *Quick Setup Guide*. For more information about network setup please see the *Network User's Guide* on the Documentation CD-ROM.

Accessing Brother Support (Windows®)

You can find all the contacts you will need, such as Web support (Brother Solutions Center) on the Installation CD-ROM.

- Click **Brother Support** on the main menu. The following screen will appear:

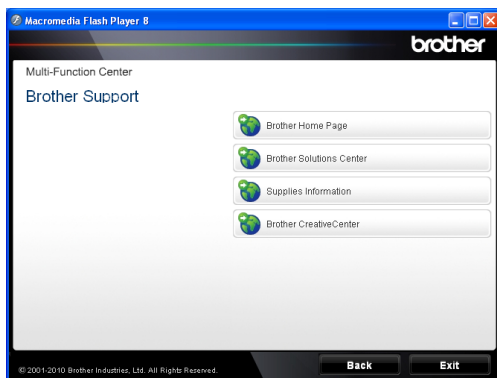

- To access our website, click **Brother Home Page**.
- For the latest news and product support information, click **Brother Solutions Center**.
- To visit our website for original Brother Supplies, click **Supplies Information**.
- To access the Brother CreativeCenter for FREE photo projects and printable downloads, click **Brother CreativeCenter**.
- To return to the main page, click **Back** or if you have finished, click **Exit**.

Accessing Brother Support (Macintosh)

You can find all the contacts you will need, such as Web support (Brother Solutions Center) on the Installation CD-ROM.

- Double-click the **Brother Support** icon. The following screen will appear:

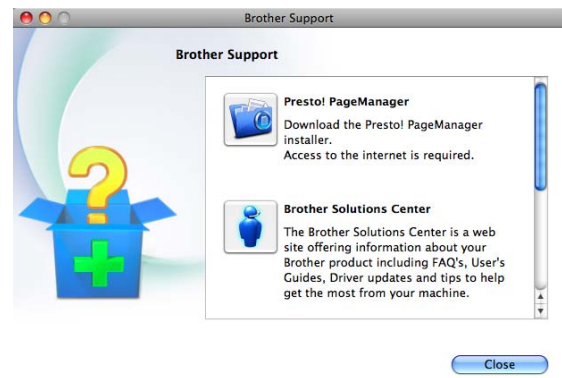

- To download and install Presto! PageManager, click **Presto! PageManager**.
- For the latest news and product support information, click **Brother Solutions Center**.
- To visit our website for original Brother Supplies, click **Supplies Information**.

Control panel overview

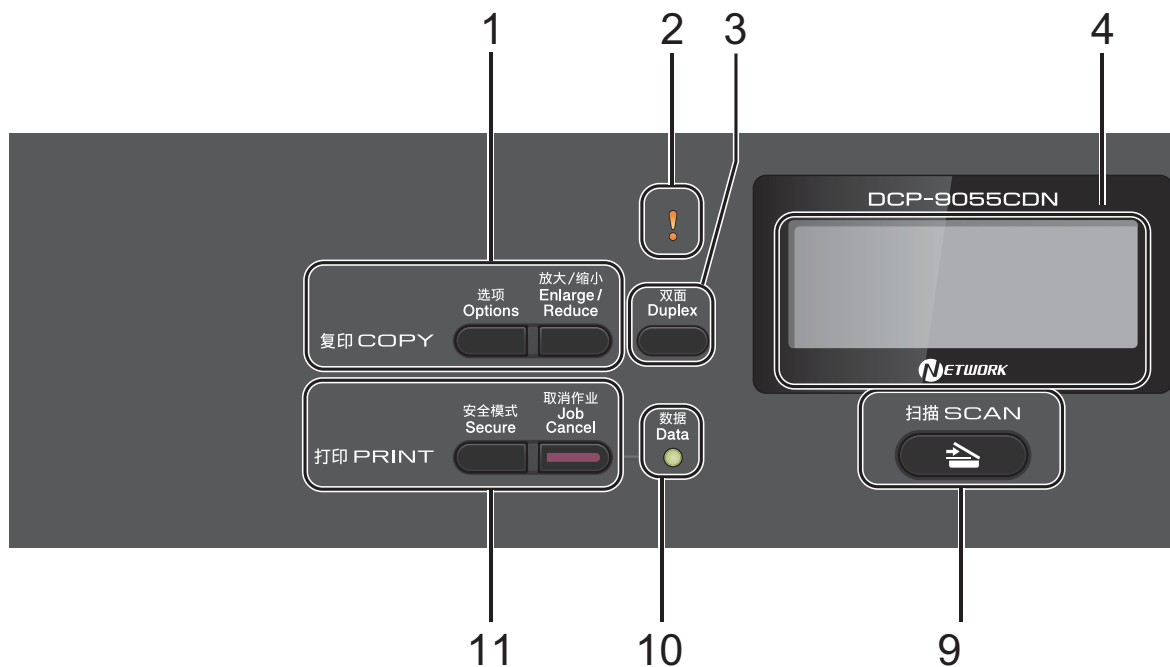

1 COPY keys:

Options

You can quickly and easily choose temporary settings for copying.

Enlarge/Reduce

Reduces or enlarges copies.

2 Error LED

Blinks in orange when the LCD displays an error or an important status message.

3 Duplex

You can choose Duplex to copy on both sides of the paper.

4 LCD

Displays messages to help you set up and use your machine.

5 Clear

Deletes entered data or lets you cancel the current setting.

Menu

Lets you access the Menu to program your settings in this machine.

OK

Lets you store your settings in the machine.

Selection keys:

◀ or ▶

Press to scroll backwards or forwards through menu selections.

▲ or ▼

Press to scroll through the menus and options.

6 Numeric keys

Use these keys to enter text.

7 Stop/Exit

Stops an operation or exits from a menu.

8 Start:

Color

Lets you start making copies in full color.

Mono

Lets you start making copies in black & white.

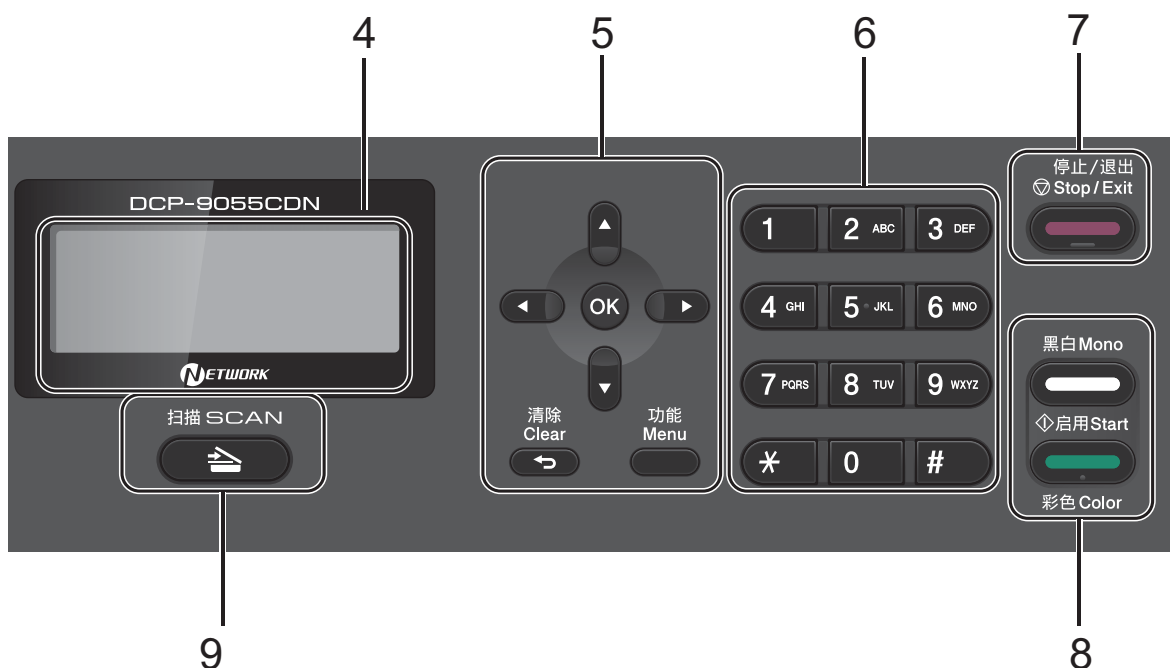
**9 SCAN:****SCAN**

Puts the machine in Scan mode.

10 Data LED

The LED will flash depending on the machine status.

11 PRINT keys:**Secure**

You can print data saved in the memory when you enter your four-digit password. (For details about using the Secure key, see the *Software User's Guide*.)

When using Secure Function Lock, you can switch restricted users by holding down ◀ as you press **Secure**. (See *Secure Function Lock 2.0* in *Chapter 2* of the *Advanced User's Guide*.)



Job Cancel

Cancels a programmed print job and clears it from the machine's memory. To cancel multiple print jobs, hold down this key until the LCD shows *Job Cancel (All)*.

Data LED indications

The **Data** LED (light emitting diode) will flash depending on the machine's status.



LED	Machine Status	Description
○	Ready Mode	The machine is ready to print, in sleep mode, there is no print data, or the power switch is off.
 Green (blinking)	Receiving Data	The machine is either receiving data from the computer, processing data in memory, or printing data.
 Green	Data Remaining in Memory	Print data remains in the machine memory.

Volume settings

Beeper volume

When the beeper is on, the machine will beep when you press a key or make a mistake. You can choose a range of volume levels, from High to Off.

- 1 Press **Menu**, **1**, **2**.
- 2 Press **▲** or **▼** to choose **Off**, **Low**, **Med** or **High**.
Press **OK**.
- 3 Press **Stop/Exit**.

2

Loading paper

Loading paper and print media

The machine can feed paper from the standard paper tray, optional lower tray or multi-purpose tray.

When you put paper into the paper tray, note the following:

- If your application software supports paper size selection on the print menu, you can select it through the software. If your application software does not support it, you can set the paper size in the printer driver or by using the control panel buttons.

Loading paper in the standard paper tray

You can load up to 250 sheets for Tray 1 (Standard paper tray) and 500 sheets for Tray 2 (Optional lower tray). Paper can be loaded up to the maximum paper mark (▼▼▼) on the sliding paper with guide. (For recommended paper to use, see *Paper capacity of the paper trays* on page 20.)

Printing on plain paper, thin paper or recycled paper from the standard paper tray

- 1 Pull the paper tray completely out of the machine.

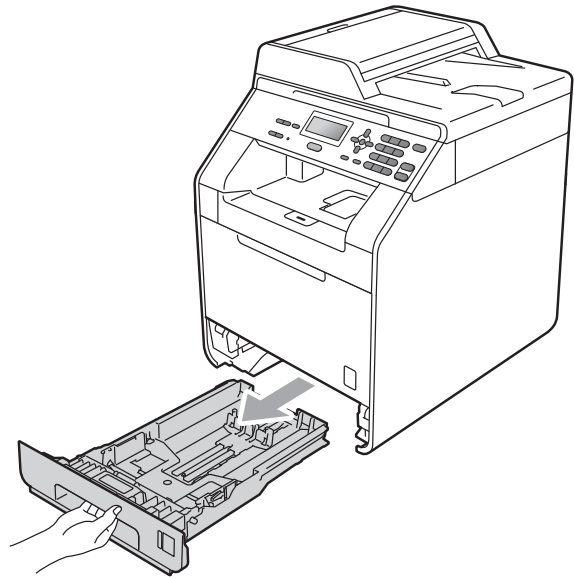

⚠ WARNING

DO NOT touch the shaded parts shown in the illustration. These rollers may be rotating at high speed.

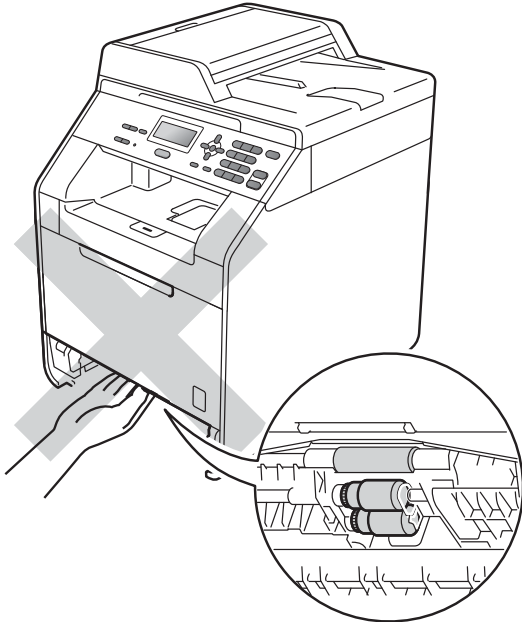

- 2 While pressing the green paper-guide release lever (1), slide the paper guides to fit the paper size you are loading in the tray. Make sure that the guides are firmly in the slots.

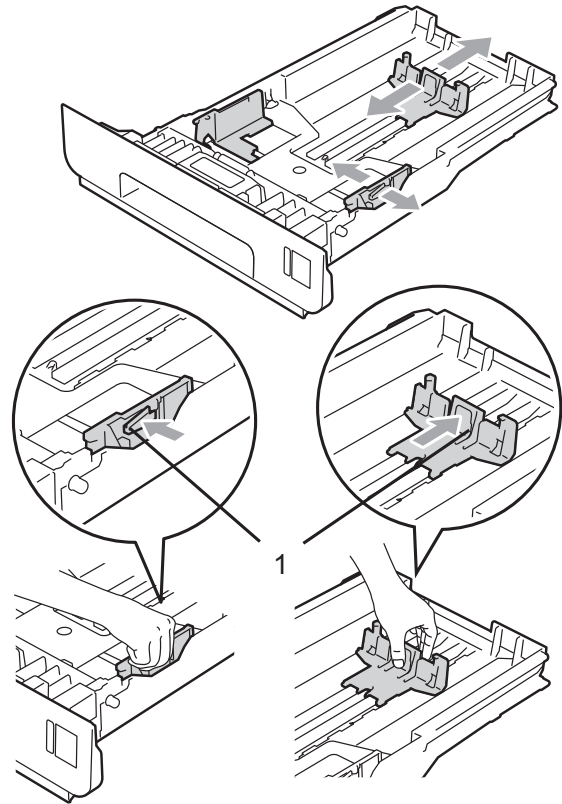

- 3 Fan the stack of paper well to avoid paper jams and misfeeds.

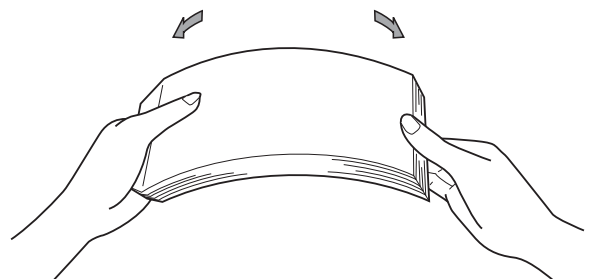

- 4 Put paper in the tray and make sure:
- The paper is below the maximum paper mark (▼▼▼) (1).
Over filling the paper tray will cause paper jams.
 - The side to be printed on must be face down.
 - The paper guides touch the sides of the paper so it will feed properly.

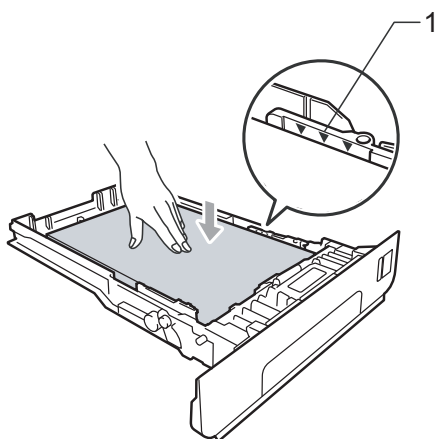

- 5 Put the paper tray firmly back in the machine. Make sure that it is completely inserted into the machine.
- 6 Lift up the support flap (1) to prevent paper from sliding off the face-down output tray or remove each page as soon as it comes out of the machine.

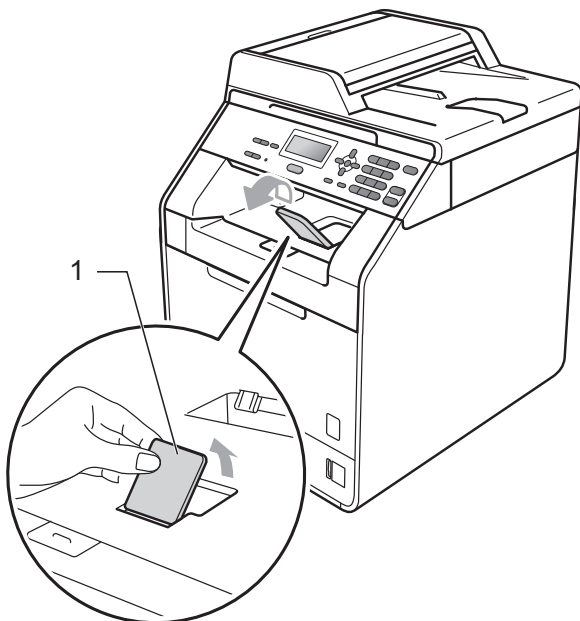

Loading paper in the multi-purpose tray (MP tray)

You can load up to 3 envelopes or special print media in the MP tray or up to 50 sheets of plain paper. Use this tray to print or copy on thick paper, bond paper, labels or envelopes. (For recommended paper to use, see *Paper capacity of the paper trays* on page 20.)

Printing on plain paper, bond paper, labels or glossy paper from the MP tray

- 1 Open the MP tray and lower it gently.

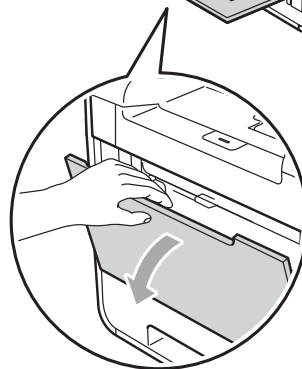
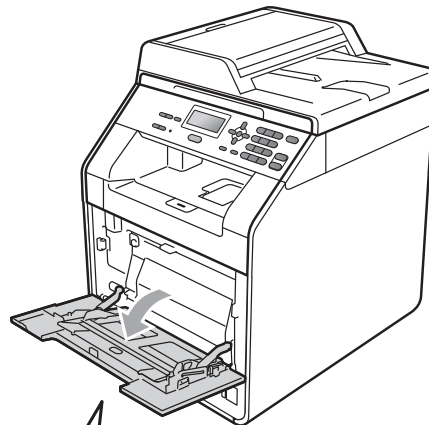

- 2 Pull out the MP tray support and unfold the flap (1).

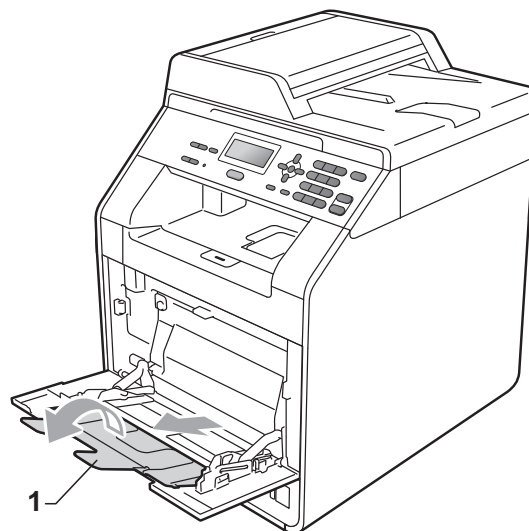

- 3 Put paper in the MP tray and make sure:
- The paper stays under the maximum paper mark (1).
 - The paper edge is positioned between the arrows (2).
 - The side to be printed on must be face up with the leading edge (top of the paper) in first.

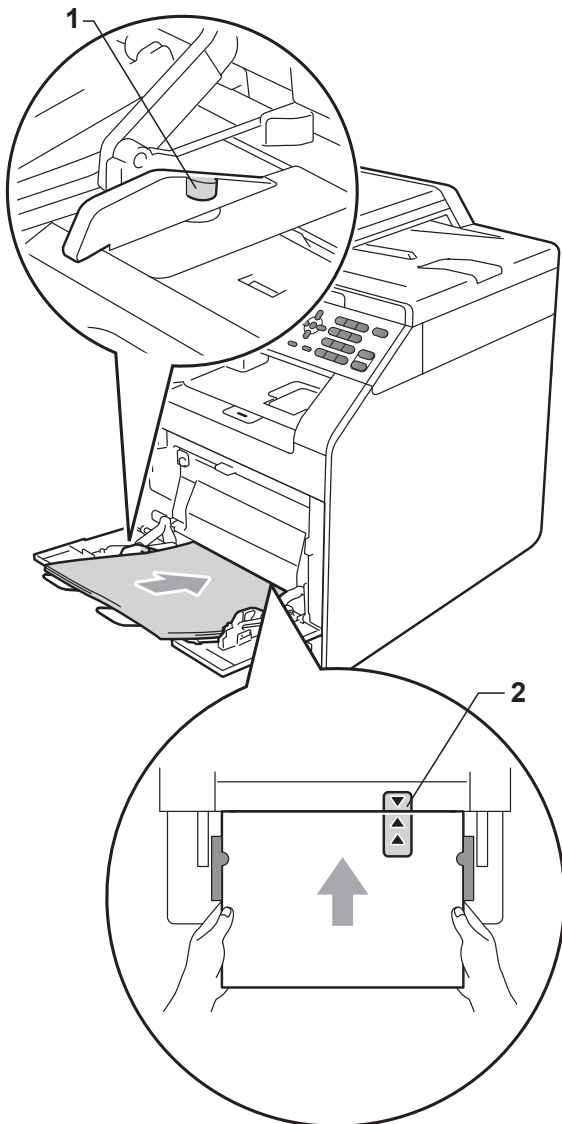

- 4 Lift up the support flap to prevent paper from sliding off the face-down output tray, or remove each page as soon as it comes out of the machine.



Printing on envelopes and thick paper from the MP tray

Before loading, press the corners and sides of the envelopes to make them as flat as possible.

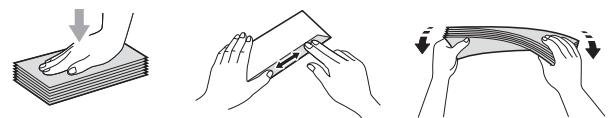

Note

When you are using glossy paper, put only one sheet at a time in the MP tray to avoid a paper jam.

- 1 Open the MP tray and lower it gently.

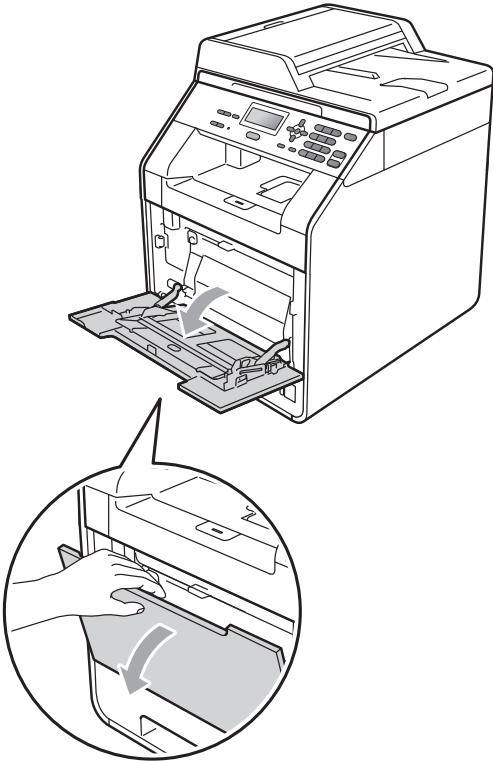

- 2 Pull out the MP tray support and unfold the flap (1).

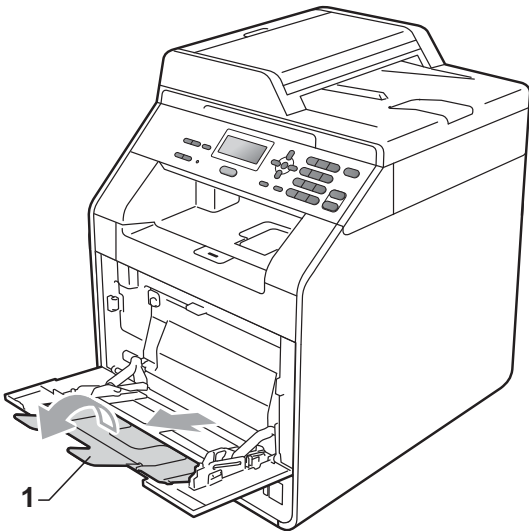

- 3 Lift up the support flap to prevent envelopes and thick sheets of paper from sliding off the face down output tray. If the support flap is closed you should remove each envelope as soon as it comes out of the machine.

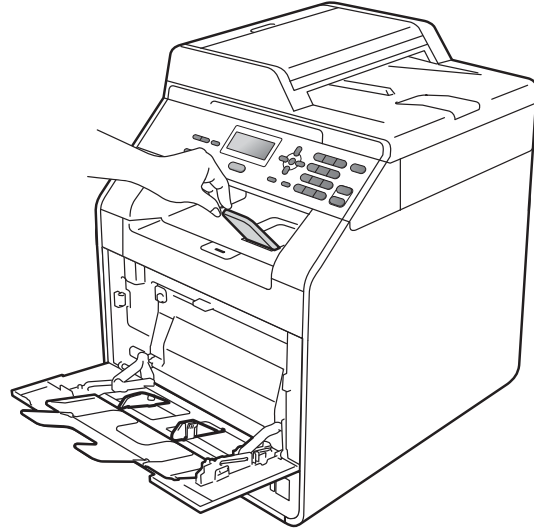

- 4 Put up to 3 envelopes or up to 25 sheets of thick paper (163 g/m²) in the MP tray. If you add more envelopes or paper it may cause a jam. Make sure:
 - The top of envelope edge is positioned between the arrows (1).
 - The side to be printed on must be face up.

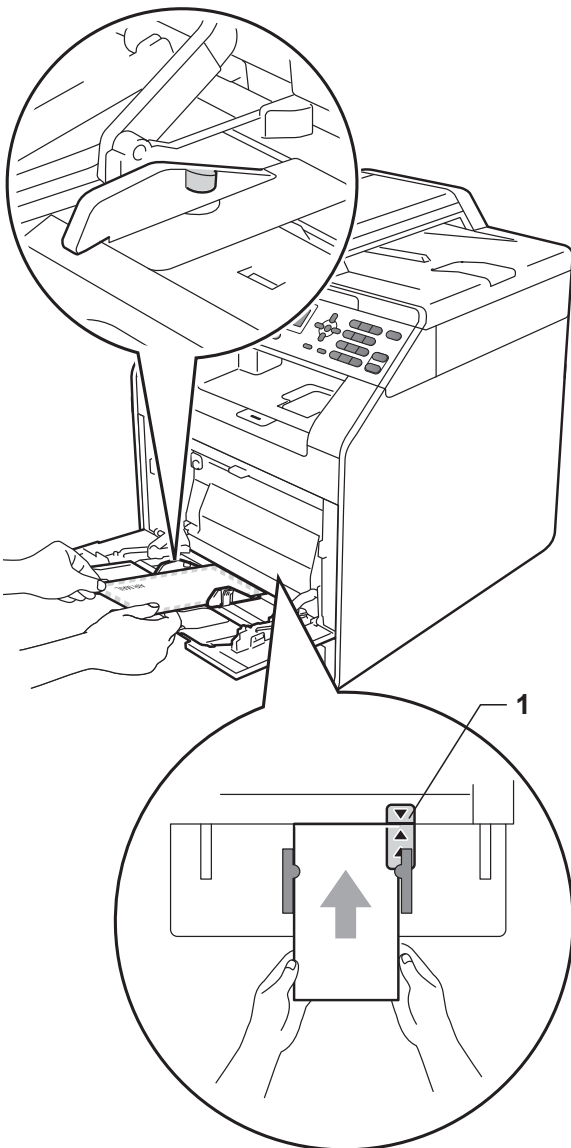

- 5 Open the back cover (Face-up output tray).

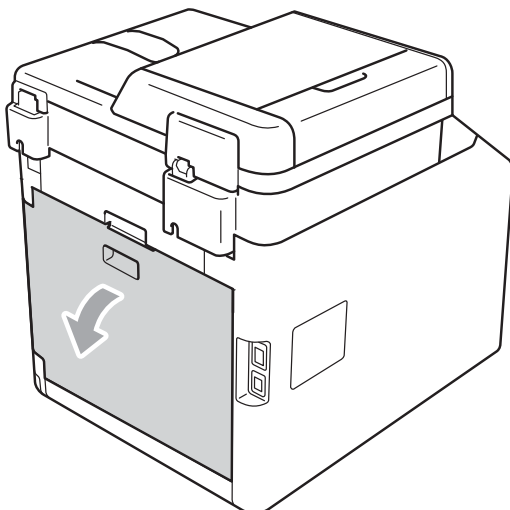

- 6 Pull down the two gray levers, one on the left-hand side and one on the right-hand side, to the envelope position as shown in the illustration below.

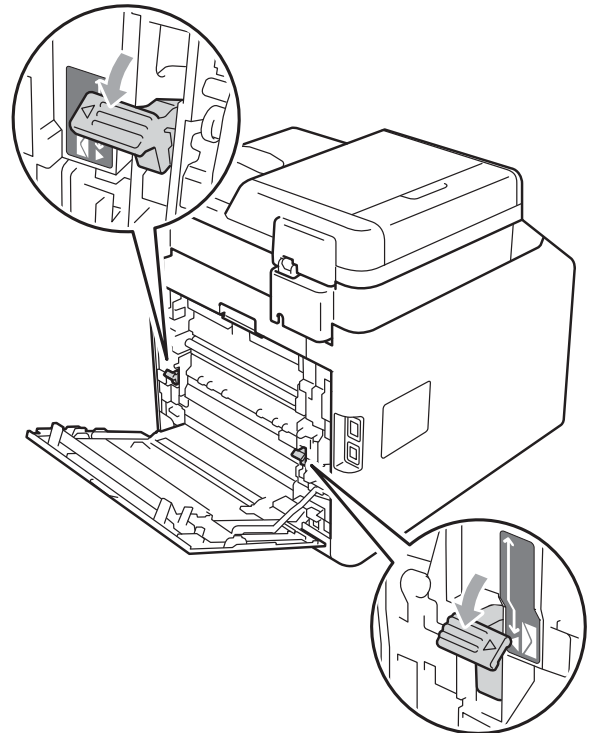

- 7 Close the back cover.
- 8 Send the print data to the machine.
- 9 When you have finished printing, open the back cover and reset the two gray levers which are pulled down at step 6 back to the original position.



Note

- Remove each printed envelope immediately to prevent a paper jam.
- If your thick paper curls during printing, put only one sheet at a time in the MP tray and open the back cover (back output tray) to let the printed pages exit to the back output tray.

- To easily remove a small printout from the output tray, lift up the scanner by using both hands as shown in the illustration.

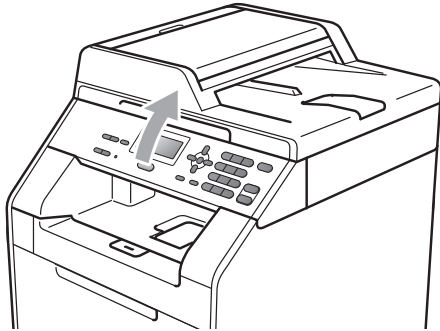

- You can still use the machine while the scanner is up. To close the scanner, push it down with both hands.

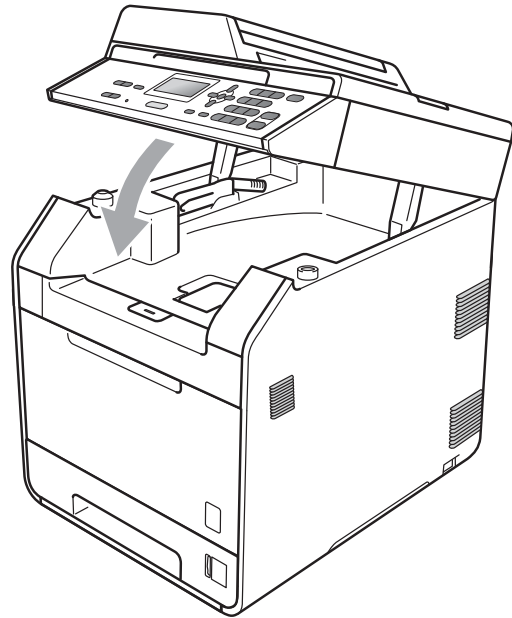

Scannable area

The figures below show unscannable areas for Copying.

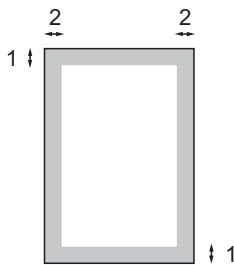

Document Size	Top (1) Bottom (1)	Left (2) Right (2)
Letter	4 mm	3.96 mm
A4	4 mm	2 mm

Note

This unscannable area shown above is for a single copy or a 1 in 1 copy using A4 size paper. The area that cannot be scanned will vary by paper size.

Unprintable area when printing from a computer

When using the printer driver the printable area is smaller than the paper size. The figures below show unprintable areas.

Portrait

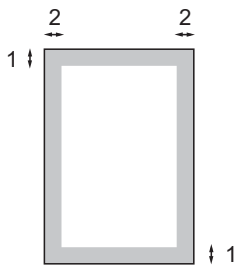

Landscape

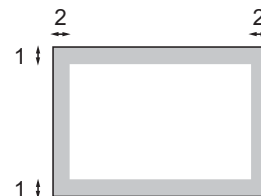

	Windows® printer driver and Macintosh printer driver BRScript printer driver for Windows® and Macintosh
1	4.23 mm
2	4.23 mm



Note

The area that cannot be printed on may vary depending on the paper size and the printer driver you are using. The unprintable area shown above is for A4 size paper.

Paper settings

Paper Type

Set up the machine for the type of paper you are using. This will give you the best print quality.

- 1 Do one of the following:
 - To set the paper type for the MP Tray press **Menu, 1, 1, 1, 1**.
 - To set the paper type for Tray#1 press **Menu, 1, 1, 1, 2**.
 - To set the paper type for Tray#2 ¹ press **Menu, 1, 1, 1, 3** if you installed the optional tray.

¹ Tray#2 appears only if the optional tray is installed.

- 2 Press **▲** or **▼** to choose *Thin, Plain, Thick, Thicker, Recycled Paper* or *Glossy Paper*. Press **OK**.

- 3 Press **Stop/Exit**.



Note

You can choose *Glossy Paper* for MP Tray.

Paper Size

You can use the following sizes of paper for printing copies: A4, Letter, Legal, Executive, A5, A5 L, A6, B5, B6, Folio (8.5 in. × 13 in.), 16K (195 × 270mm), 16K (184 × 260mm) and 16K (197 × 273mm).

When you change the size of paper in the tray, you will also need to change the setting for paper size at the same time so your machine can fit the document.

- 1 Do one of the following:
 - To set the paper size for the MP Tray press **Menu, 1, 1, 2, 1**.

- To set the paper size for Tray#1 press **Menu, 1, 1, 2, 2**.
- To set the paper size for Tray#2 ¹ press **Menu, 1, 1, 2, 3** if you installed the optional tray.

¹ Tray#2 appears only if the optional tray is installed.

- 2 Press **▲** or **▼** to choose *A4, Letter, Legal, Executive, A5, A5 L, A6, B5, B6, Folio, 16K (195×270mm), 16K (184×260mm), 16K (197×273mm)* or *Any*. Press **OK**.

- 3 Press **Stop/Exit**.



Note

- The *Any* option appears only when you choose the MP tray.
- If you choose *Any* for the MP Tray Paper Size: You must choose *MP Only* for the Tray Use setting. You cannot use the *Any* Paper Size selection for the MP tray when making N in 1 copies. You must choose one of the other available Paper Size selections for the MP tray.
- A5 L and A6 size are not available for the Tray#2.
- 16K (195×270mm), 16K (184×260mm) and 16K (197×273mm) size are not available for Tray#1 and Tray#2.

Tray Use in copy mode

You can change the priority tray that the machine will use for printing copies.

When you choose *Tray#1 Only, MP Only* or *Tray#2 Only* ¹, the machine pulls the paper only from that tray. If the selected tray is out of paper, *No Paper* will appear on the LCD. Insert the paper in the empty tray.

To change the tray setting follow the instructions below:

- 1 Press **Menu, 1, 4, 1**.

- 2 Press ▲ or ▼ to choose Tray#1 Only, Tray#2 Only¹, MP Only, MP>T1>T2¹ or T1>T2¹>MP. Press **OK**.

¹ Tray#2 Only or T2 appears only if the optional tray is installed.

- 3 Press **Stop/Exit**.



Note

- When loading the documents in the ADF and MP>T1>T2 or T1>T2>MP is selected, the machine looks for the tray with the most suitable paper and pulls paper from that tray. If no tray has suitable paper, the machine pulls paper from the higher priority tray.
- When using the scanner glass, your document is copied from the higher priority tray even if more suitable paper is in another paper tray.

Tray Use in print mode

You can change the default tray the machine will use for printing from your computer.

- 1 Press **Menu, 1, 4, 2**.
- 2 Press ▲ or ▼ to choose Tray#1 Only, Tray#2 Only¹, MP Only, MP>T1>T2¹ or T1>T2¹>MP. Press **OK**.

¹ Tray#2 Only or T2 appears only if the optional tray is installed.

- 3 Press **Stop/Exit**.

Acceptable paper and other print media

Print quality may vary according to the type of paper you are using.

You can use the following types of print media: thin paper, plain paper, thick paper, bond paper, recycled paper, glossy paper, labels or envelopes.

For best results, follow the instructions below:

- DO NOT put different types of paper in the paper tray at the same time because it may cause paper jams or misfeeds.
- For correct printing, you must choose the same paper size from your software application as the paper in the tray.
- Avoid touching the printed surface of the paper immediately after printing.
- Before you buy a lot of paper, test a small quantity to make sure the paper is suitable.

Recommended paper and print media

Paper Type	Item
Plain Paper	APP Blue Flagship 70 g/m ²
	APP Gold Flagship 80 g/m ²
	Advanced Agro Double A 80 g/m ²

Type and size of paper

The machine feeds paper from the installed standard paper tray, multi-purpose tray or optional lower tray.

The name for the paper trays in the printer driver and this Guide are as follows:

Tray and optional unit	Name
Standard paper tray	Tray 1
Multi-purpose tray	MP Tray
Optional lower tray	Tray 2

Paper capacity of the paper trays

	Paper size	Paper types	No. of sheets
Paper Tray (Tray 1)	A4, Letter, Legal, B5, Executive, A5, A5 (Long Edge), A6, B6, Folio ¹	Plain paper, Thin paper and Recycled paper	up to 250 [80 g/m ²]
Multi-purpose Tray (MP Tray)	Width: 69.8 to 216 mm Length: 116 to 406.4 mm	Plain paper, Thin paper, Thick paper, Thicker paper, Bond paper, Recycled paper, Envelopes, Labels and Glossy paper	50 sheets [80 g/m ²] 3 Envelopes 1 Glossy paper
Optional lower Tray (Tray 2)	A4, Letter, Legal, B5, Executive, A5, B6, Folio ¹	Plain paper, Thin paper and Recycled paper	up to 500 [80 g/m ²]

¹ Folio size is 215.9 mm x 330.2 mm

Recommended paper specifications

The following paper specifications are suitable for this machine.

Basis weight	70-90 g/m ²
Thickness	80-110 μm
Roughness	Higher than 20 sec.
Stiffness	90-150 cm ³ /100
Grain direction	Long grain
Volume resistivity	10e ⁹ -10e ¹¹ ohm
Surface resistivity	10e ⁹ -10e ¹² ohm-cm
Filler	CaCO ₃ (Neutral)
Ash content	Below 23 wt%
Brightness	Higher than 80%
Opacity	Higher than 85%

- Use paper made for plain paper copying.

- Use paper that is 70 to 90 g/m².
- Use long grain paper with a neutral Ph value, and a moisture content of approx. 5%.
- This machine can use recycled paper that meets DIN 19309 specifications.

Handling and using special paper

The machine is designed to work well with most types of xerographic and bond paper. However, some paper variables may have an effect on print quality or handling reliability. Always test samples of paper before purchasing to ensure desirable performance. Store paper in its original packaging and keep it sealed. Keep the paper flat and away from moisture, direct sunlight and heat.

Some important guidelines when selecting paper are:

- DO NOT use inkjet paper because it may cause a paper jam or damage your machine.
- Preprinted paper must use ink that can withstand the temperature of the machine's fusing process 392 degrees Fahrenheit (200 degrees centigrade).
- If you use bond paper, paper having a rough surface or paper that is wrinkled or creased, the paper may exhibit degraded performance.
- When you are using glossy paper, put only one sheet at a time in the MP tray to avoid a paper jam.

Types of paper to avoid

! IMPORTANT

Some types of paper may not perform well or may cause damage to your machine.

DO NOT use paper:

- that is highly textured

- that is curled or warped

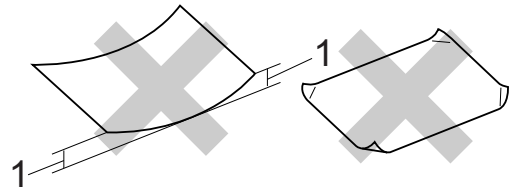

1 A curl of 2 mm or greater may cause jams to occur.

- that is coated or has a chemical finish
- that is damaged, creased or folded
- that exceeds the recommended weight specification in this guide
- with tabs and staples
- with letterheads using low temperature dyes or thermography
- that is multipart or carbonless
- that is designed for inkjet printing

If you use any of the types of paper listed, they may damage your machine. This damage may not be covered under any Brother warranty or service agreement.

Envelopes

Most envelopes designed for laser printers will be suitable for your machine. However, some envelopes may have feed and print-quality problems because of the way they have been made. A suitable envelope should have edges with straight, well-creased folds. The envelope should lie flat and not be of baggy or flimsy construction. You should buy quality envelopes from a supplier who understands that you will be using the envelopes in a laser machine.

We recommend that you print a test envelope to make sure the print results are what you want.

Types of envelopes to avoid

! IMPORTANT

DO NOT use envelopes:

- that are damaged, curled, wrinkled or an unusual shape
- that are extremely shiny or textured
- with clasps, staples, snaps or tie strings
- with self-adhesive closures
- that are of a baggy construction
- that are not sharply creased
- that are embossed (have raised writing on them)
- that were previously printed by a laser machine
- that are pre-printed on the inside
- that cannot be arranged neatly when stacked
- that are made of paper that weighs more than the paper weight specifications for the machine
- with edges that are not straight or consistently square
- with windows, holes, cut-outs or perforations
- with glue on surface as shown in figure below

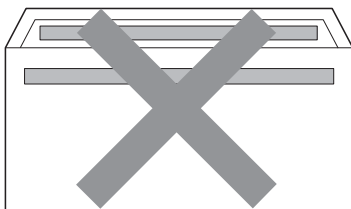

- with double flaps

- with each side folded as shown in figure below

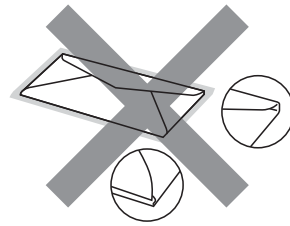

If you use any of the types of envelopes listed above, they may damage your machine. This damage may not be covered under any Brother warranty or service agreement.

Labels

The machine will print on most types of labels designed for use with a laser machine. Labels should have an adhesive that is acrylic-based since this material is more stable at the high temperatures in the fuser unit. Adhesives should not come in contact with any part of the machine, because the label stock may stick to the drum unit or rollers and cause jams and print quality problems. No adhesive should be exposed between the labels. Labels should be arranged so that they cover the entire length and width of the sheet. Using labels with spaces may result in labels peeling off and causing serious jams or print problems.

All labels used in this machine must be able to withstand a temperature of 392 degrees Fahrenheit (200 degrees centigrade) for a period of 0.1 seconds.

Types of labels to avoid

Do not use labels that are damaged, curled, wrinkled or an unusual shape.

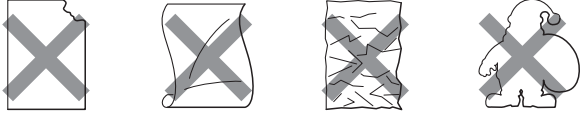

! IMPORTANT

- DO NOT feed part used label sheets. The exposed carrier sheet will damage your machine.
- Label sheets should not exceed the paper weight specifications described in this User's Guide. Labels exceeding this specification may not feed or print correctly and may cause damage to your machine.
- DO NOT reuse or insert labels that have previously been used or are missing a few labels on the sheet.

3

Loading documents

How to load documents

You can make copies, and scan from the ADF (Automatic Document Feeder) and the scanner glass.

Using the automatic document feeder (ADF)

The ADF can hold up to 35 pages and feeds each sheet individually. Use standard 80 g/m² paper and always fan the pages before putting them in the ADF.

Document Sizes Supported

Length:	147.3 to 356.0 mm
Width:	147.3 to 215.9 mm
Weight:	64 to 90 g/m ²

How to load documents

! IMPORTANT

- DO NOT leave thick documents on the scanner glass. If you do this, the ADF may jam.
- DO NOT use paper that is curled, wrinkled, folded, ripped, stapled, paper-clipped, pasted or taped.
- DO NOT use cardboard, newspaper or fabric.
- To avoid damaging your machine while using the ADF, DO NOT pull on the document while it is feeding.

Note

- To scan documents that are not suitable for the ADF, see *Using the scanner glass* on page 25.
- It is easier to use the ADF if you are loading a multiple page document.
- Make sure documents with correction fluid or written with ink are completely dry.

- 1 Unfold the ADF document support (1) and the ADF document output support flap (2).

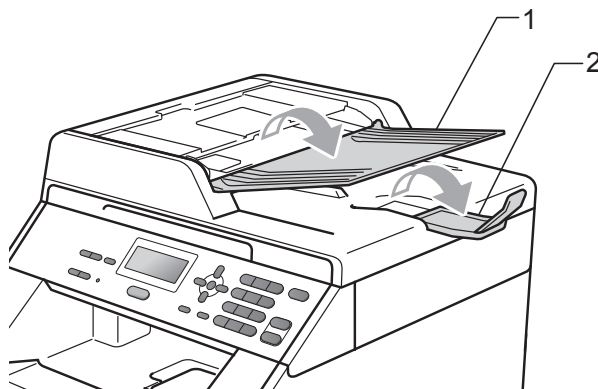

- 2 Fan the pages well.
- 3 Place your document **face up, top edge first** in the ADF until the LCD display message changes and you feel it touch the feed rollers.
- 4 Adjust the paper guides (1) to fit the width of your document.

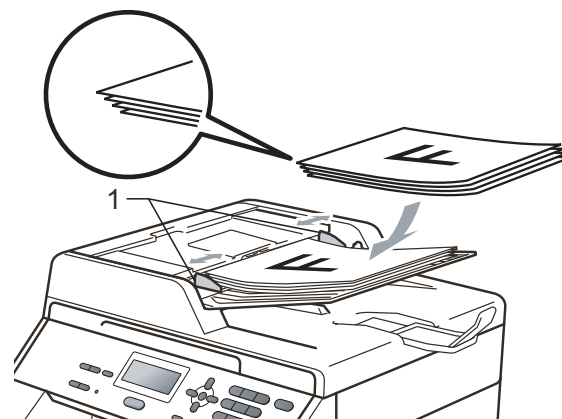

Using the scanner glass

You can use the scanner glass to copy or scan pages of a book one page at a time.

Document Sizes Supported

Length:	Up to 297.0 mm
Width:	Up to 215.9 mm
Weight:	Up to 2.0 kg

How to load documents



Note

To use the scanner glass, the ADF must be empty.

- 1 Lift the document cover.
- 2 Using the document guidelines on the left and top, place the document face down in the upper left corner of the scanner glass.

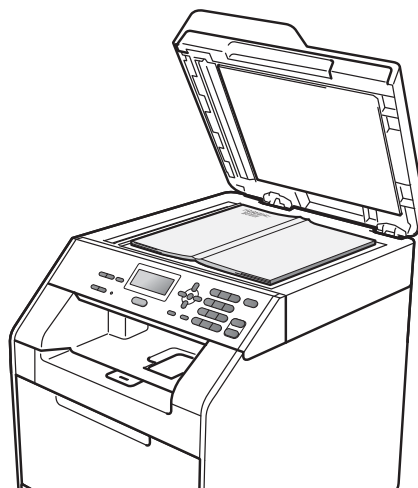
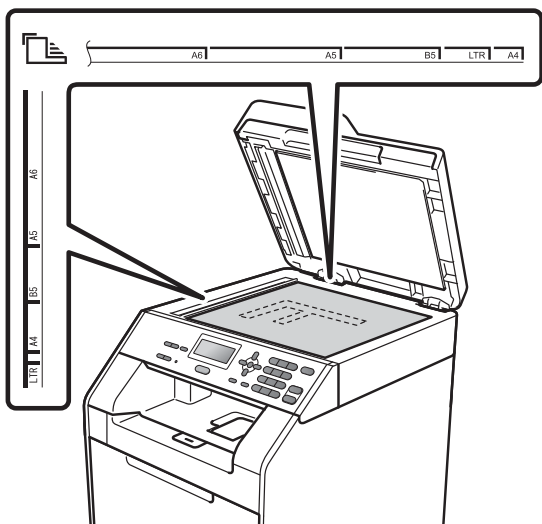

- 3 Close the document cover.

! IMPORTANT

If the document is a book or is thick do not slam the cover or press on it.

4

Making copies

How to copy

The following steps show the basic copy operation. For details about each option, see the *Advanced User's Guide*.

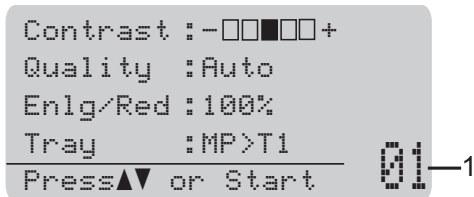

1 No. of Copies

You can enter the number of copies you want by using the numeric keys.

- 1 Do one of the following to load your document:
 - Place the document face up in the ADF. (See *Using the automatic document feeder (ADF)* on page 24.)
 - Load your document face down on the scanner glass. (See *Using the scanner glass* on page 25.)

2 Press **Mono Start** or **Color Start**.



Note

If the LCD shows **Please Wait** and the machine stops copying while you are making multiple copies, please wait for 30 to 40 seconds until the machine finishes the color registration and cleaning process of the belt unit.

Stop copying

To stop copying, press **Stop/Exit**.

Copy settings

You can change the following copy settings:

Press ▲ or ▼ to scroll through the copy settings. When the setting you want is highlighted, press **OK**. For details about changing the following copy settings, see *Copy settings* in *Chapter 3* of the *Advanced User's Guide*.

- Enlg/Red (Enlarge/Reduce)
- Stack/Sort
- Quality
- Contrast
- Brightness
- Color Adjust
- Page Layout
- Tray Select
- Duplex

Printing a document

The machine can receive data from your computer and print it. To print from a computer, install the printer driver. (See *Printing for Windows*[®] or *Printing and Faxing for Macintosh* in *Software User's Guide* for the details about the print settings.)

- 1 Install the Brother printer driver on the Installation CD-ROM. (See the *Quick Setup Guide*.)
- 2 From your application, choose the Print command.
- 3 Choose the name of your machine in the **Print** dialog box and click **Properties**.
- 4 Choose the settings you want in the **Properties** dialog box.
 - Paper Size
 - Orientation
 - Copies
 - Media Type
 - Print Quality
 - Color / Mono
 - Multiple Page
 - Duplex / Booklet
 - Paper Source
- 5 Click **OK** to begin printing.

6

How to scan to a computer

Scanning a document as PDF file using ControlCenter4 (Windows®)

(For Macintosh users) See *Scanning* in the *Software User's Guide*.

Note

- The screens on your PC may vary depending on your model.
- The illustrations in this chapter are based on "**Advanced Mode**" interface.

ControlCenter4 is a software utility that lets you quickly and easily access the applications you use most often. Using ControlCenter4 eliminates the need to manually launch specific applications. You can use ControlCenter4 on your computer.

- 1 Load your document. (See *How to load documents* on page 24.)
- 2 Open ControlCenter4 by clicking **start/All Programs/Brother/XXX-XXXX** (where XXX-XXXX is your model name)/**ControlCenter4**. The ControlCenter4 application will open.
- 3 Choose **Home Mode** or **Advanced Mode** before you use ControlCenter4.

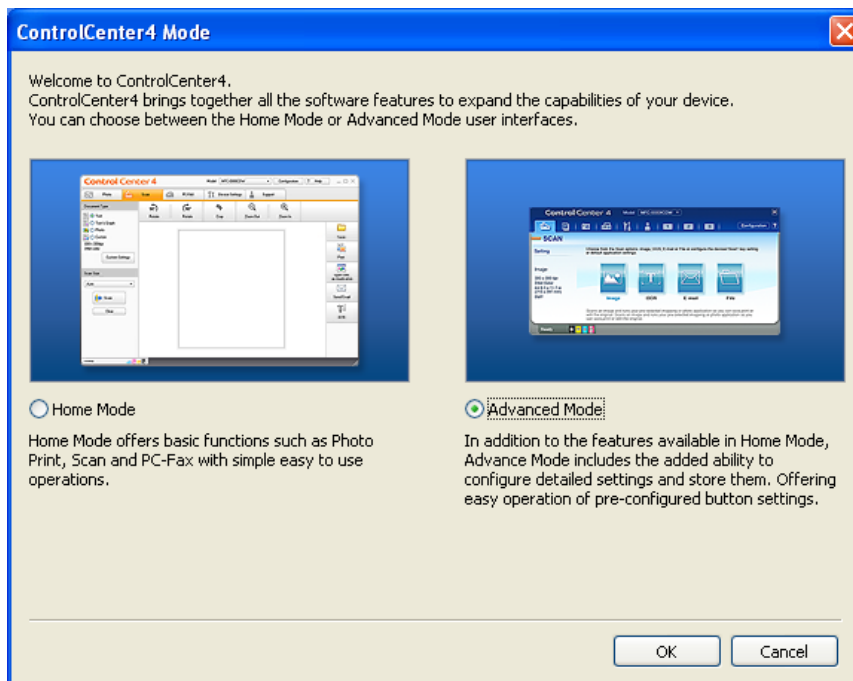

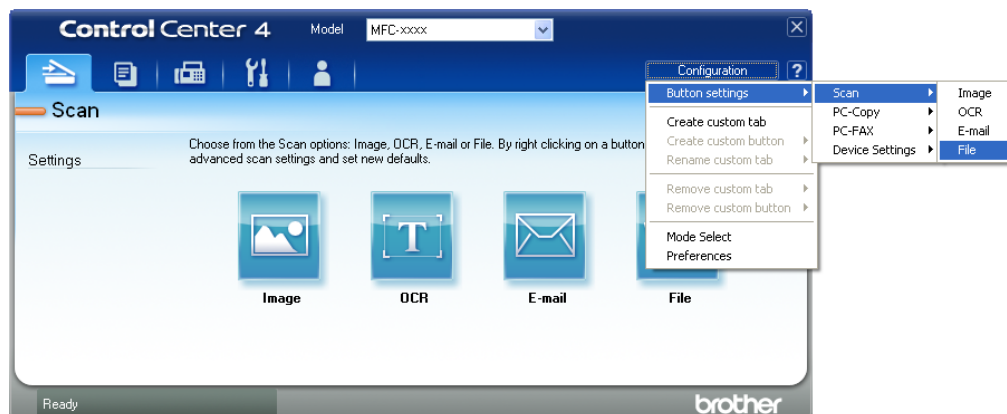

- 4 Make sure the machine you want to use is selected from the **Model** pull-down list.

- 5 Set the file type for saving to a folder. By default, the scanned data is saved as **JPEG (*.jpg)**. Click **Configuration**, and then select **Button settings**, **Scan** and **File**.

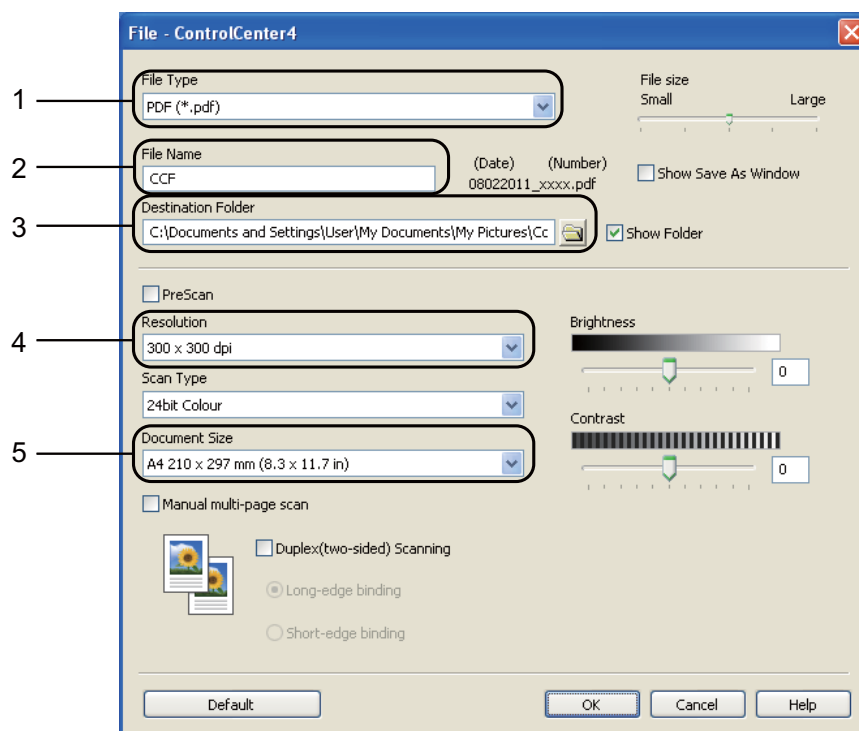

The configuration dialog box appears. You can change the default settings.



- 1 Choose **PDF (*.pdf)** from the **File Type** pull-down list.
- 2 You can enter the file name you want to use for the document.
- 3 You can save the file to the default folder, or choose your preferred folder by clicking the  **Browse** button.
- 4 You can choose a scanning resolution from the **Resolution** pull-down list.
- 5 You can choose the document size from the pull-down list.

- 6 Click **OK**.

- 7 Click **File**.
The machine starts the scanning process. The folder where the scanned data is saved will open automatically.

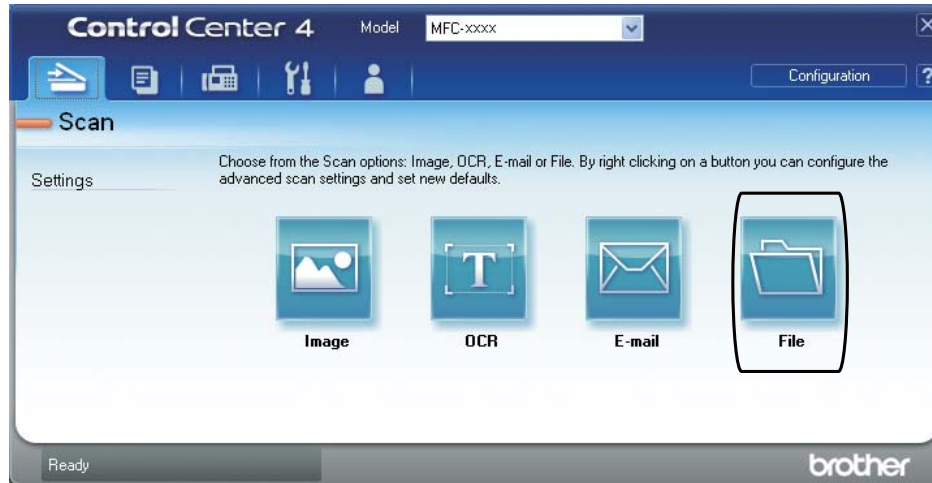

Changing the SCAN key settings

Before scanning

To use the machine as a scanner, install a scanner driver. If the machine is on a network, configure it with a TCP/IP address.

- Install the MFL-Pro Suit (including scanner drivers) on the Installation CD-ROM. (See the *Quick Setup Guide*.)
- Configure the machine with a TCP/IP address if network scanning does not work. (See *Configuring Network Scanning* in the *Software User's Guide*.)

SCAN key settings

You can change your machine's **SCAN** key settings using ControlCenter4.

- 1 Open ControlCenter4 by clicking **start/All Programs/Brother/XXX-XXXX** (where XXX-XXXX is your model name)/**ControlCenter4**. The ControlCenter4 application will open.
- 2 Make sure the machine you want to use is selected from the **Model** pull-down list.
- 3 Click the **Device Settings** tab.
- 4 Click **Device Scan Settings**.

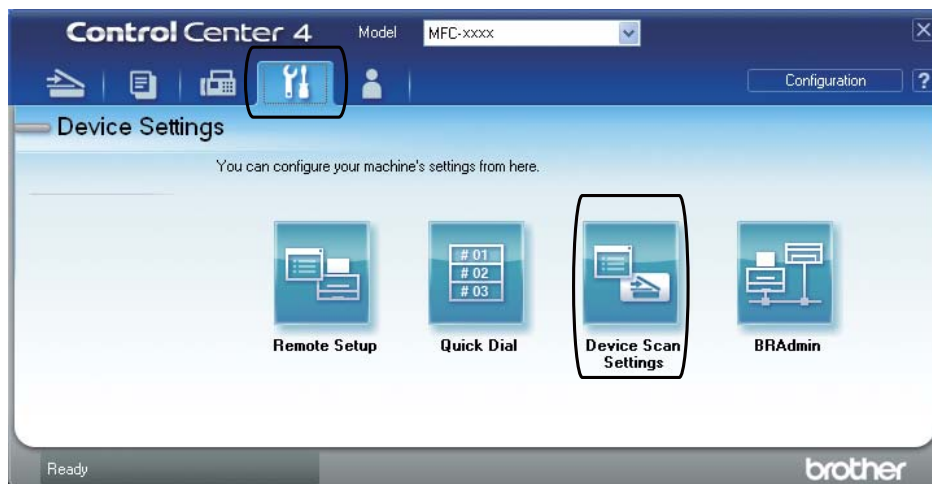

- 5 Choose the **File** tab. You can change the default settings.

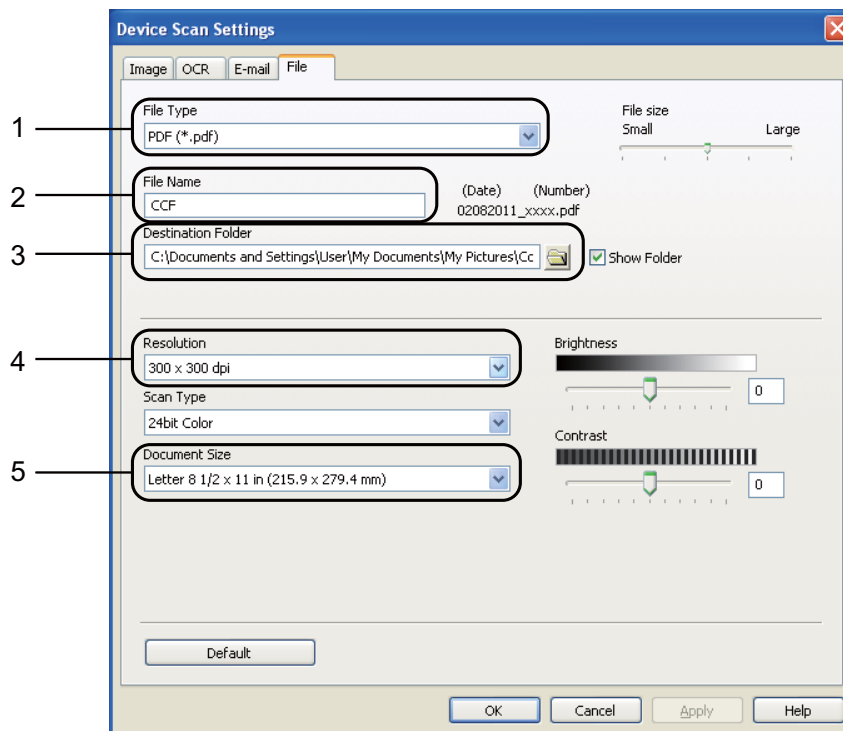

- 1 You can choose the file type from the pull-down list.
- 2 You can enter the file name you want to use for the document.
- 3 You can save the file to the default folder, or choose your preferred folder by clicking the  **Browse** button.
- 4 You can choose a scanning resolution from the **Resolution** pull-down list.
- 5 You can choose the document size from the pull-down list.

- 6 Click **OK**.

Scanning using the SCAN key

- 1 Load your document. (See *How to load documents* on page 24.)
- 2 Press  (**SCAN**).
- 3 Press ▲ or ▼ to choose `Scan to PC`.
Press **OK**.
- 4 Press ▲ or ▼ to choose `File`.
Press **OK**.
- 5 If you want to change the duplex setting, press ▲ or ▼ to choose `1sided`, `2sided (L) edge` or `2sided (S) edge`.
Press **OK**.
- 6 (For Network users)
Press ▲ or ▼ to choose the destination computer you want to send to.
Press **OK**.
If the LCD prompts you to enter a PIN number, enter the 4-digit PIN number for the destination computer using the dial pad on the control panel.
Press **OK**.
- 7 Press **Mono Start** or **Color Start**.
The machine starts the scanning process.



Note

Choose the scan mode you want.

Scan to:

- Network
 - FTP
 - E-mail (Scan to PC)
 - Image (Scan to PC)
 - OCR (Scan to PC)
 - File (Scan to PC)
-

A

Routine maintenance

Replacing the consumable items

The following messages appear on the LCD in the Ready mode. These messages provide advanced warnings to replace the consumable items before they reach the end of their life. To avoid any inconvenience, you may want to buy spare consumable items before the machine stops printing.

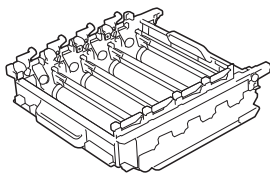
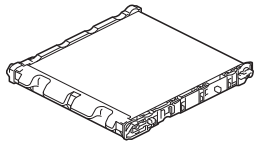
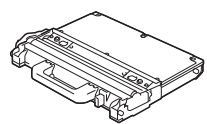
Standard Toner See <i>Replacing a Toner cartridge</i> on page 37.	Cyan TN-370C	Drum unit (DR-370CL) See <i>Replacing the drum unit</i> on page 43.	
	Magenta TN-370M		
	Yellow TN-370Y		
	Black TN-370BK		
High Capacity Toner See <i>Replacing a Toner cartridge</i> on page 37.	Cyan TN-375C	Belt unit (BU-300CL) See <i>Replacing the belt unit</i> on page 49.	
	Magenta TN-375M	Waste toner box (WT-300CL) See <i>Replacing the waste toner box</i> on page 54.	
	Yellow TN-375Y		
	Black TN-378BK		

LCD messages	Consumable item to replace	Model name	Approximate life	How to replace
Toner Low Prepare New X Toner Cartridge. X = Black, Cyan, Magenta, Yellow	Toner cartridge, Black	TN-370BK (Standard toner cartridge), TN-378BK (High capacity toner cartridge),	2,500 pages (Standard toner cartridge) ^{1 2} 6,000 pages (High capacity toner cartridge) ^{1 2}	See page 37.
	Toner cartridge, Cyan	TN-370C (Standard toner cartridge), TN-375C (High capacity toner cartridge),	1,500 pages (Standard toner cartridge) ^{1 2} 3,500 pages (High capacity toner cartridge) ^{1 2}	
	Toner cartridge, Magenta	TN-370M (Standard toner cartridge), TN-375M (High capacity toner cartridge),		
	Toner cartridge, Yellow	TN-370Y (Standard toner cartridge), TN-375Y (High capacity toner cartridge)		
WT Box End Soon	Waste toner box	WT-300CL	50,000 pages ¹	See page 54.

¹ A4 or Letter size single-sided pages.

² Approx. cartridge yield is declared in accordance with ISO/IEC 19798.

You will need to clean the machine regularly and replace the consumable items when the following messages are displayed on the LCD.

LCD messages	Consumable item to replace	Model name	Approximate life	How to replace
Replace Toner	Toner cartridge, Black	TN-370BK (Standard toner cartridge), TN-378BK (High capacity cartridge)	2,500 pages (Standard toner cartridge) ^{1 2} 6,000 pages (High capacity cartridge) ^{1 2}	See page 37.
	Toner cartridge, Cyan	TN-370C (Standard toner cartridge), TN-375C (High capacity cartridge)	1,500 pages (Standard toner cartridge) ^{1 2} 3,500 pages (High capacity cartridge) ^{1 2}	
	Toner cartridge, Magenta	TN-370M (Standard toner cartridge), TN-375M (High capacity cartridge)		
	Toner cartridge, Yellow	TN-370Y (Standard toner cartridge), TN-375Y (High capacity cartridge)		
Replace Parts Drum	Drum unit	DR-370CL	25,000 pages (1 page per job; Drum life is approximate and may vary by type of use.) ¹	See page 44.
Drum Stop				
Replace Parts Belt Unit	Belt unit	BU-300CL	50,000 pages ¹	See page 49.
Replace WT Box	Waste toner box	WT-300CL	50,000 pages ¹	See page 54.
Replace Parts Fuser Unit	Fuser unit		100,000 pages ¹	Call your Brother dealer for a replacement fuser unit.
Replace Parts Laser Unit	Laser unit		100,000 pages ¹	Call your Brother dealer for a replacement laser unit.
Replace Parts PF Kit 1	Paper feeding kit 1		100,000 pages ¹	Call your Brother dealer for a replacement paper feeding kit 1.
Replace Parts PF Kit 2	Paper feeding kit 2		100,000 pages ¹	Call your Brother dealer for a replacement paper feeding kit 2.
Replace Parts PF Kit MP	Paper feeding kit MP		50,000 pages ¹	Call your Brother dealer for a replacement paper feeding kit MP.

¹ A4 or Letter size single-sided pages.

² Approx. cartridge yield is declared in accordance with ISO/IEC 19798.



Note

- If you choose not to return your used consumable, please discard the used consumable according to local regulations, keeping it separate from domestic waste. If you have questions, call your local waste disposal office.
- We recommend placing used consumable items on a piece of paper to prevent accidentally spilling or scattering the material inside.

- If you use paper that is not a direct equivalent for the recommended paper, the life of consumable items and machine parts may be reduced.
- The projected life of the toner cartridges is based on ISO/IEC 19798. Frequency of replacement will vary depending on the complexity of printed pages, percentage of coverage and type of media used.

Replacing a Toner cartridge

Model Name: For the model name of toner cartridges, see *Replacing the consumable items* on page 34.

The Standard toner cartridges can print approximately 2,500 pages (black) or approximately 1,500 pages (cyan, magenta, yellow)¹. The High Yield toner cartridges can print approximately 6,000 pages (black) or approximately 3,500 pages (cyan, magenta, yellow)¹. Actual page count will vary depending on your average type of document. When a toner cartridge is running low, the LCD shows `Toner Low`.

The toner cartridges that come supplied with the machine are standard toner cartridges.

¹ Approx. cartridge yield is declared in accordance with ISO/IEC 19798.

Note

- It is a good idea to keep a new toner cartridge ready for use when you see the `Toner Low` warning.
- To ensure high quality printing, we recommend that you use only Brother Original toner cartridges. When you want to buy toner cartridges, please call your Brother dealer.
- We recommend that you clean the machine when you replace the toner cartridge. See *Cleaning and Checking the machine* on page 60.
- If you change the print density setting for lighter or darker printing, the amount of toner used will change.
- Wait to unpack the toner cartridge until immediately before you put it into the machine.

Toner Low

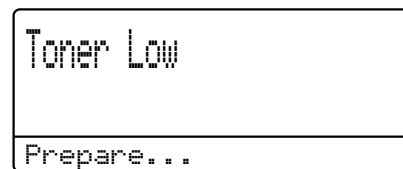

If the LCD shows `Toner Low Prepare New X Toner Cartridge.`, buy a new toner cartridge and have it ready before you get a `Replace Toner` message. The LCD shows the toner color that is near the end of its life (Cyan, Magenta, Yellow or Black).

Replace Toner

When the following message appears on the LCD, you need to replace the toner cartridge:

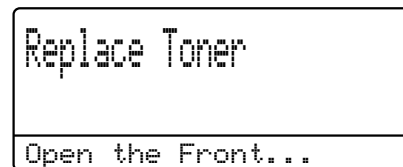

The message in the last line of the LCD indicates which color you need to replace.

The machine will stop printing until you replace the toner cartridge. A new or unused Brother Original toner cartridge will reset the `Replace Toner` mode.

Replacing the toner cartridge

- 1 Make sure that the machine is turned on.
- 2 Press the front cover release button and then open the front cover.

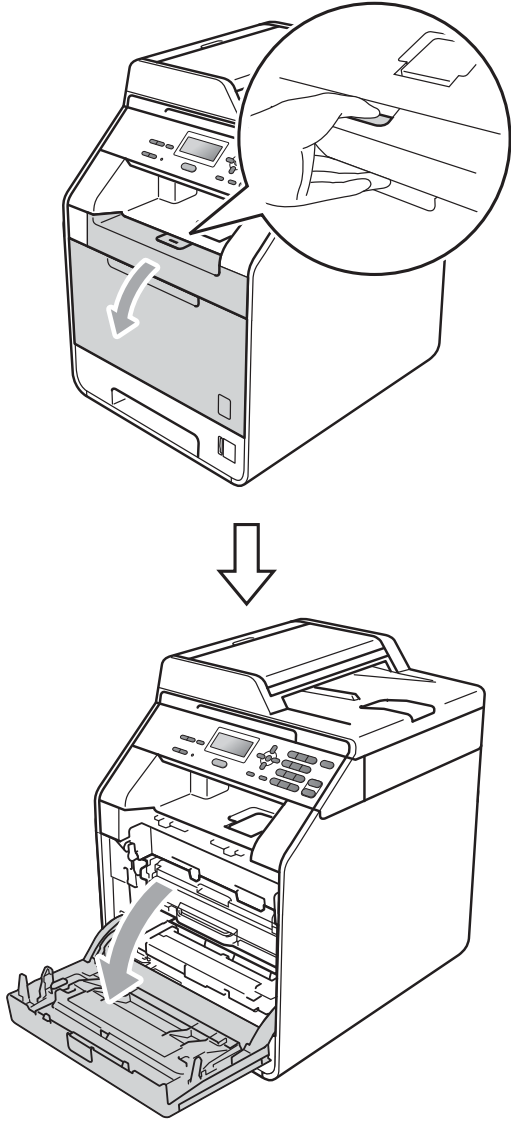

- 3 Hold the green handle of the drum unit. Pull the drum unit out until it stops.

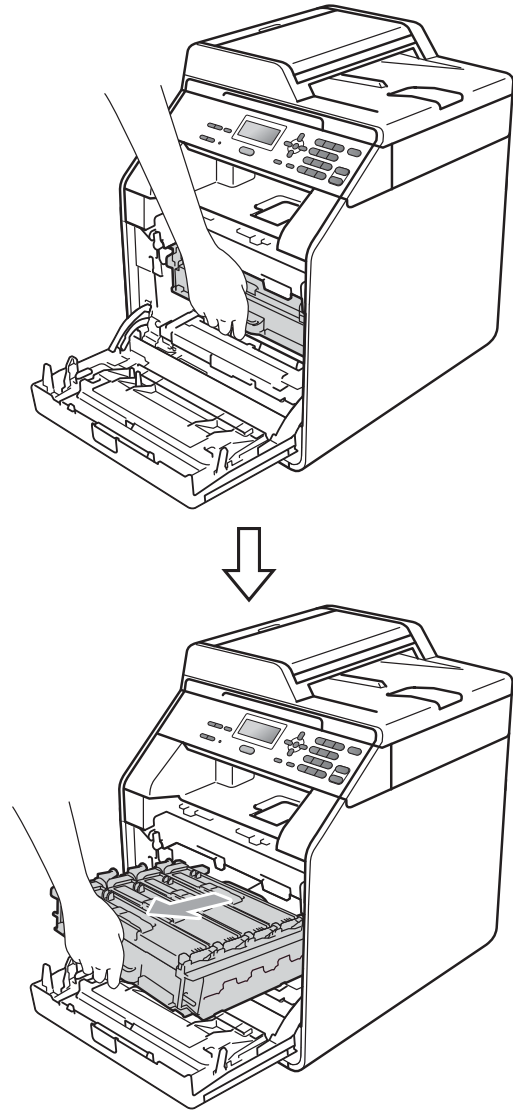

- 4 Hold the handle of the toner cartridge and slightly push it toward the machine to unlock it. Then pull it out of the drum unit. Repeat this for all the toner cartridges.

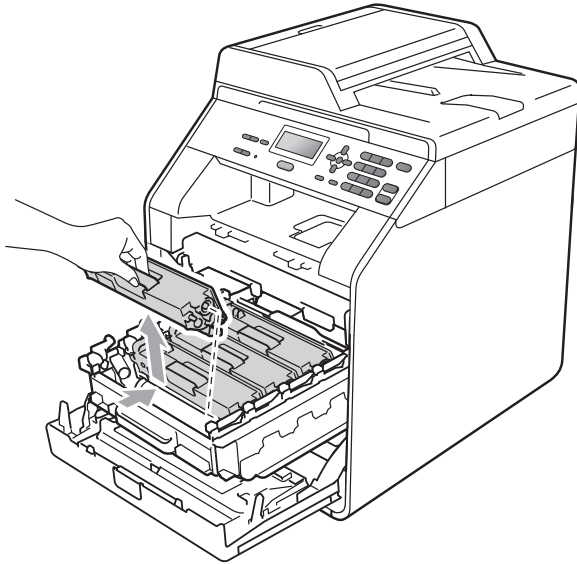

! WARNING

DO NOT put a toner cartridge into a fire. It could explode, resulting in injuries.

DO NOT use cleaning materials that contain ammonia, alcohol, any type of spray or any type of flammable substance to clean the inside or outside of the machine. Doing this may cause a fire or electrical shock.

See *To use the product safely* in the *Safety and Legal Booklet* for how to clean the machine.



Be careful not to inhale toner.

! IMPORTANT

- We recommend that you place the drum unit and/or the toner cartridge on a clean, flat, level, stable surface with a sheet of disposable paper or cloth underneath it in case you accidentally spill or scatter toner.
- Handle the toner cartridge carefully. If toner scatters on your hands or clothes, wipe or wash it off with cold water at once.
- To avoid print quality problems, DO NOT touch the shaded parts shown in the illustration.

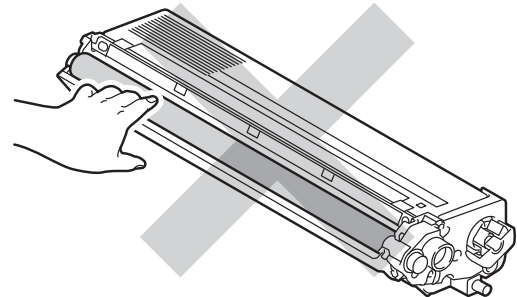

📝 Note

- Be sure to seal up the toner cartridge tightly in a suitable bag so that toner powder does not spill out of the cartridge.
- If you choose not to return your used consumable, please discard the used consumable according to local regulations, keeping it separate from domestic waste. If you have questions, call your local waste disposal office.

- 5 Push to release the latches of the corona wire cover (1), and then open the cover.

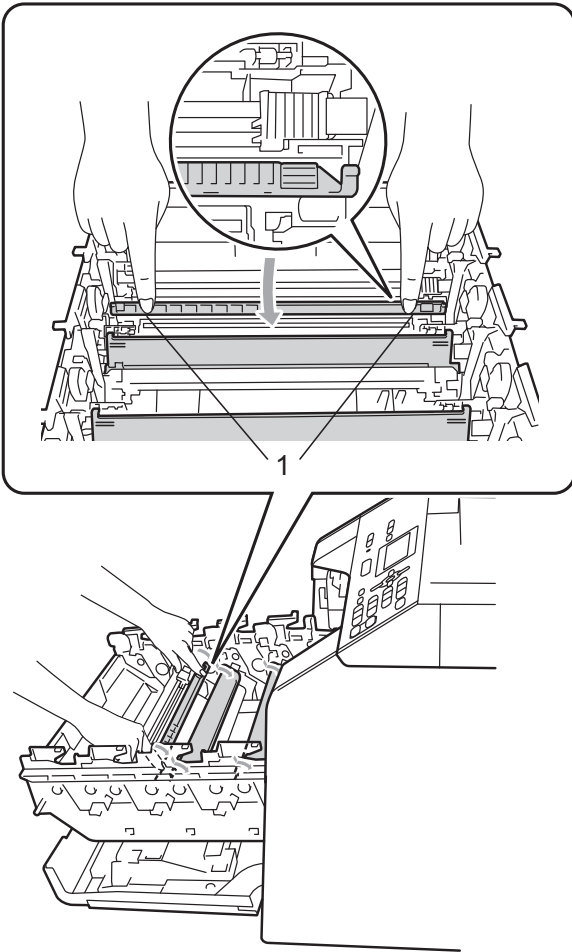

- 6 Clean the corona wire inside the drum unit by gently sliding the green tab from left to right and right to left several times.

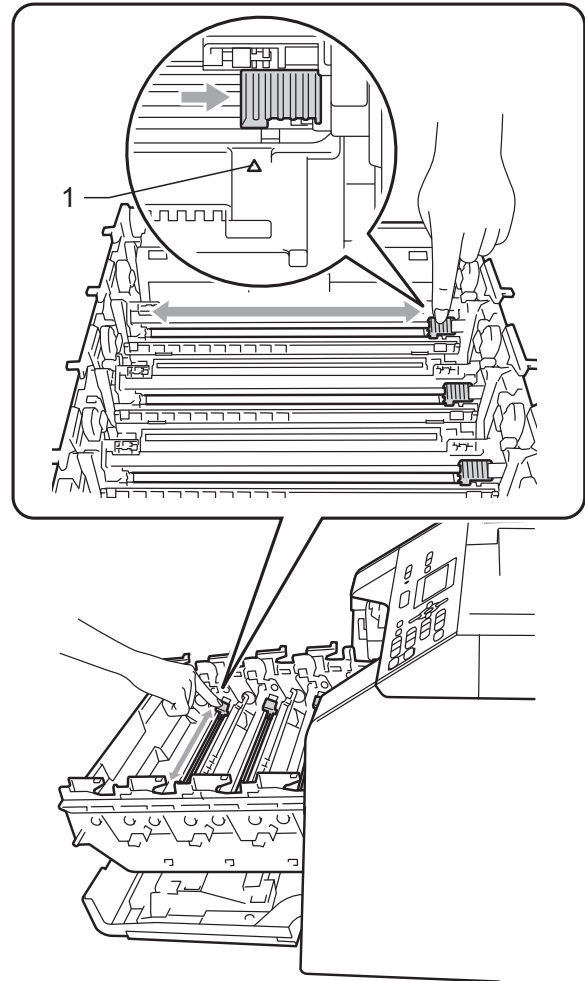

Note

Be sure to return the tab to the home position (▲) (1). If you do not, printed pages may have a vertical stripe.

- 7** Close the corona wire cover.

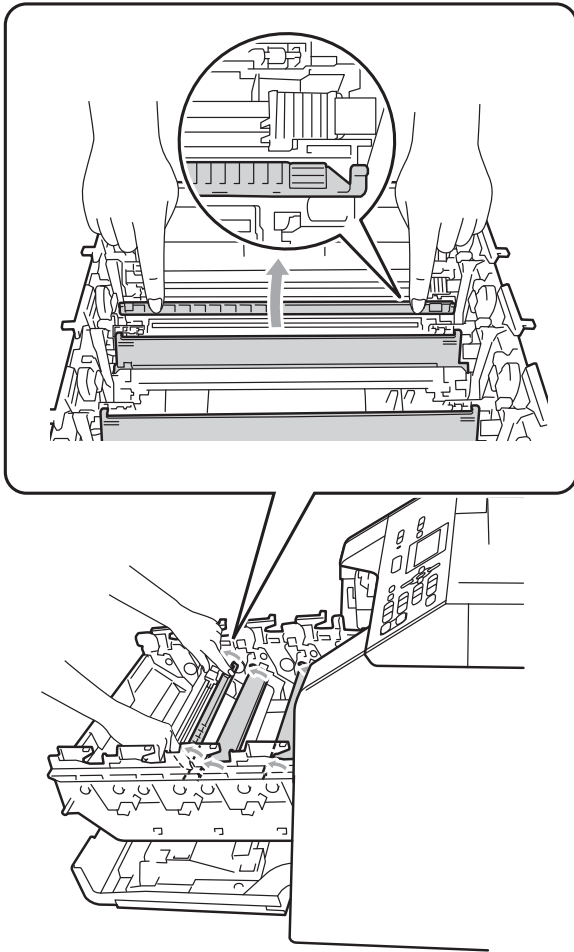

- 8** Repeat steps **5** to **7** to clean each of three remaining corona wires.

- 9** Unpack the new toner cartridge. Gently shake it from side to side several times to distribute the toner evenly inside the cartridge.

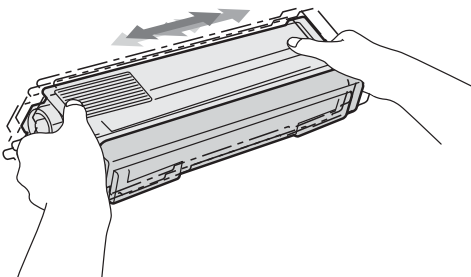

! IMPORTANT

- Unpack the toner cartridge just before you put it in the machine. If a toner cartridge is left unpacked for a long time, the toner life will be shortened.
- If an unpacked drum unit is put in direct sunlight or room light, the unit may be damaged.
- Brother machines are designed to work with toner of a particular specification and will work to a level of optimum performance when used with Brother Original toner cartridges. Brother cannot guarantee this optimum performance if toner or toner cartridges of other specifications are used. Brother does not therefore recommend the use of cartridges other than Brother Original cartridges with this machine, or the refilling of empty cartridges with toner from other sources. If damage is caused to the drum unit or other part of this machine as a result of the use of toner or toner cartridges other than Brother Original products due to the incompatibility or lack of suitability of those products with this machine, any repairs required as a result may not be covered by the warranty.

- 10** Pull off the protective cover.

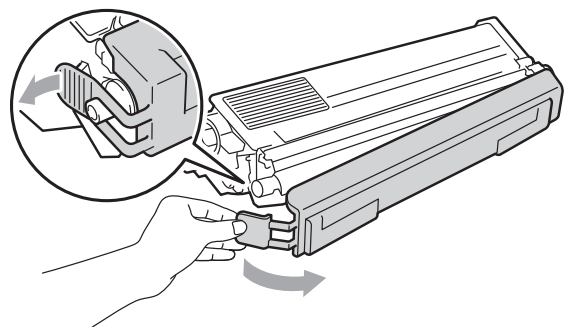

! IMPORTANT

Put the toner cartridge in the drum unit immediately after you have removed the protective cover. To prevent any degradation to the print quality, DO NOT touch the shaded parts shown in the illustrations.

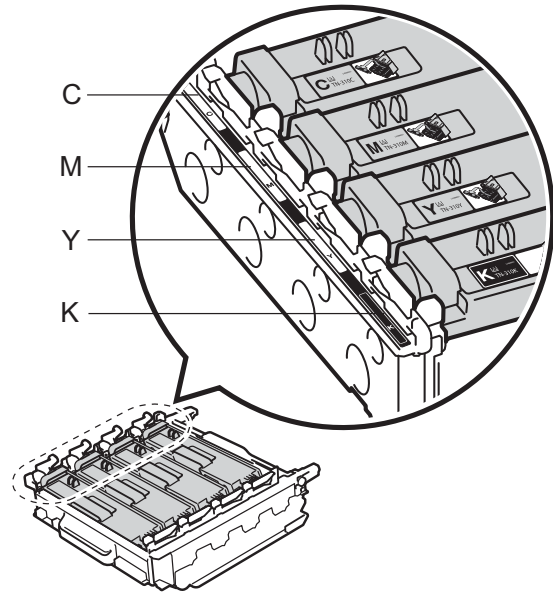
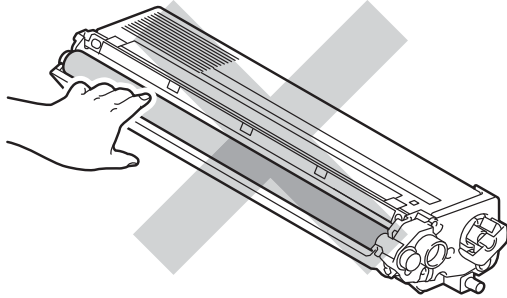

C - Cyan

M - Magenta

Y - Yellow

K - Black

- 11 Hold the handle of the toner cartridge and slide the toner cartridge into the drum unit then slightly pull it toward you until you hear it click into place. Make sure that you match the toner cartridge color to the same color label on the drum unit. Repeat this for all the toner cartridges.

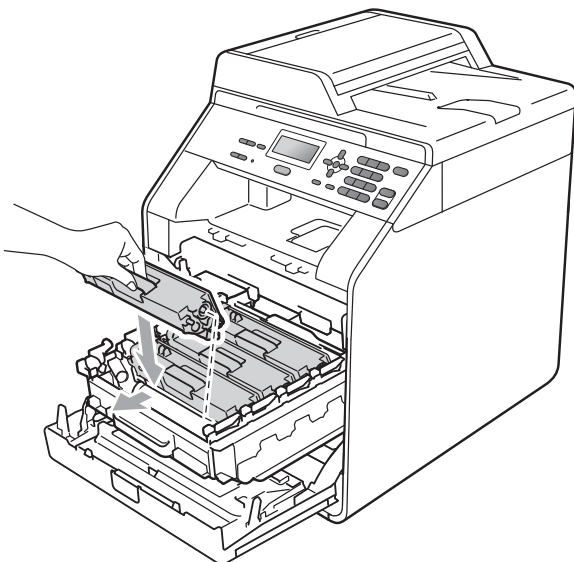

- 12 Push the drum unit in until it stops.

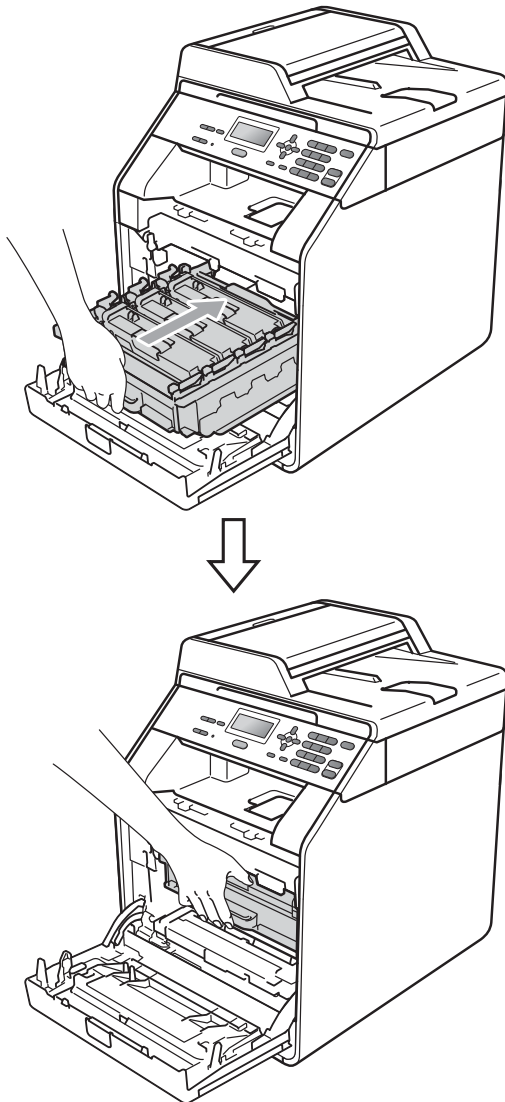

- 13 Close the front cover of the machine.



Note

After you replace a toner cartridge, DO NOT turn off the machine's power switch or open the front cover until the LCD clears the `Please Wait` message and returns to Ready mode.

Replacing the drum unit

Model name: DR-370CL

A new drum unit can print approximately 25,000 A4 or Letter size single-sided pages.

! IMPORTANT

For best performance, use a Brother Original drum unit and Brother Original toner units. Printing with a third-party drum unit or toner unit may reduce not only the print quality but also the quality and life of the machine itself. Warranty coverage may not apply to problems caused by the use of third-party drum or toner units.

Drum Error



The corona wires have become dirty. Clean the corona wires in the drum unit. (See *Cleaning the corona wires* on page 66.)

If you cleaned the corona wires and `Drum Error` was not cleared then the drum unit is at the end of its life. Replace the drum unit with a new one.

Replace Drum

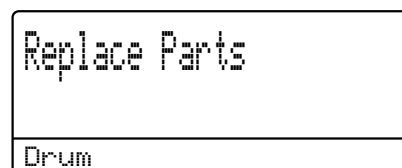

The drum unit has exceeded its rated life. Please replace the drum unit with a new one. We recommend a Brother Original drum unit be installed at this time.

After replacement, reset the drum counter by following the instructions included with the new drum unit.

Drum Stop

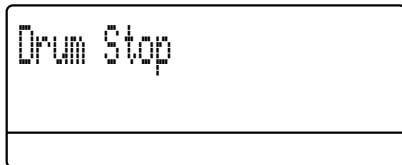

We cannot guarantee the print quality. Please replace the drum unit with a new one. We recommend a Brother Original drum unit be installed at this time.

After replacement, reset the drum counter by following the instructions included with the new drum unit.

Replacing the drum unit

! IMPORTANT

- While removing the drum unit, handle it carefully because it may contain toner. If toner scatters on your hands or clothes, wipe or wash it off with cold water at once.
- Every time you replace the drum unit, clean the inside of the machine. (See *Cleaning and Checking the machine* on page 60.)

- 1 Make sure that the machine is turned on.

- 2 Press the front cover release button and then open the front cover.

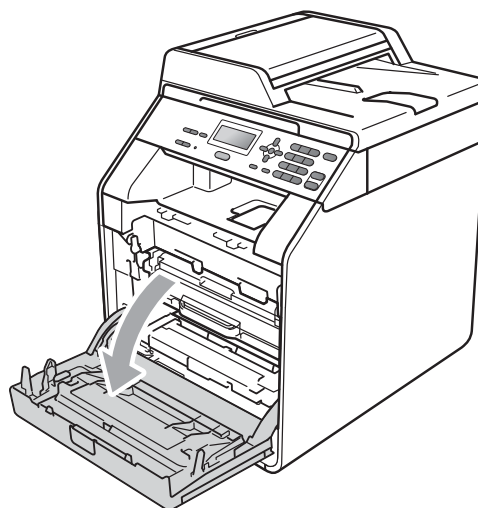
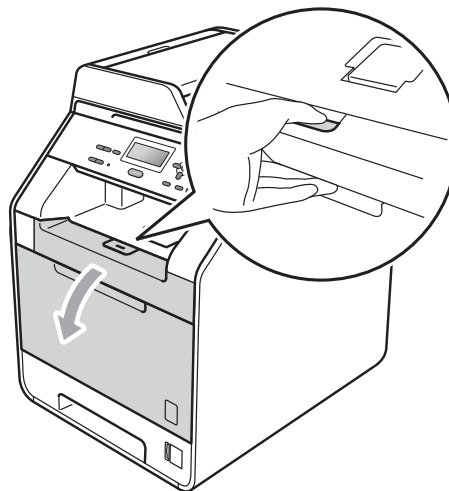

- 3 Hold the green handle of the drum unit. Pull the drum unit out until it stops.

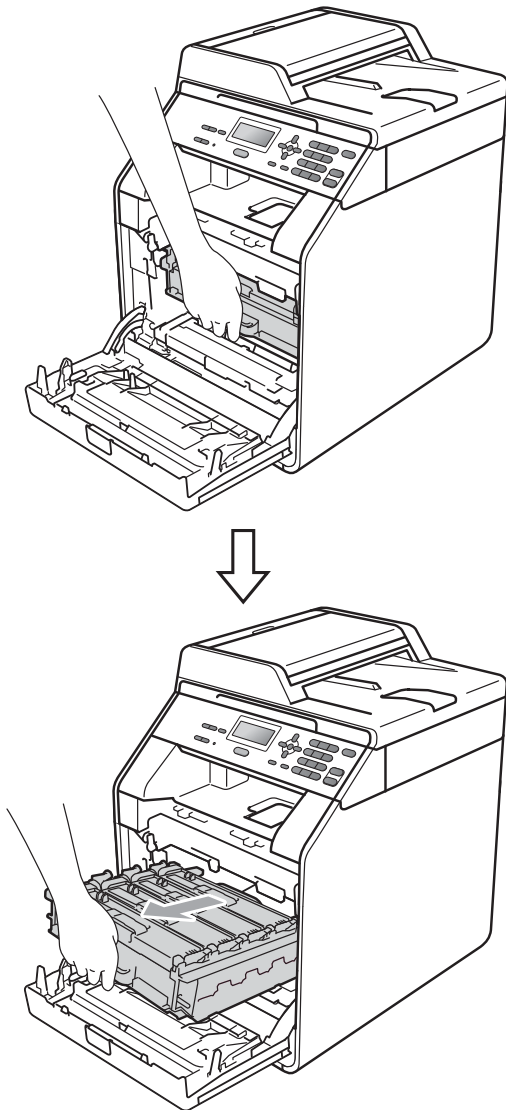

- 4 Turn the green lock lever (1) at the left of the machine anticlockwise to the release position. Holding the green handles of the drum unit, lift the front of the drum unit and remove it from the machine.

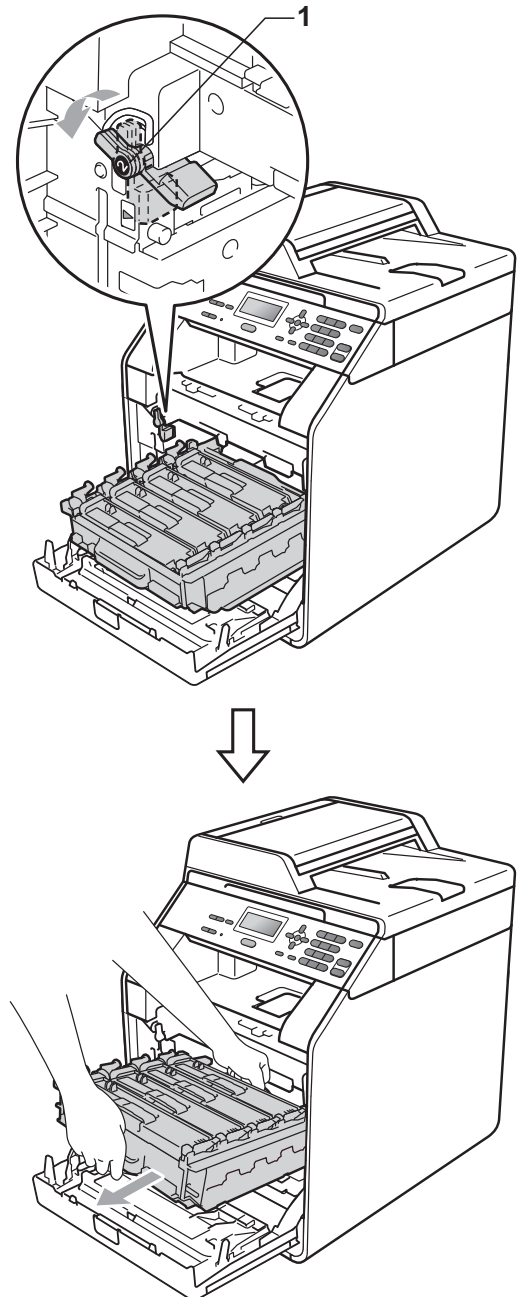

A

! IMPORTANT

- We recommend that you place the drum unit and/or the toner cartridge on a clean, flat surface with a sheet of disposable paper or cloth underneath it in case you accidentally spill or scatter toner.

- To prevent damage to the machine from static electricity, DO NOT touch the electrodes shown in the illustration.

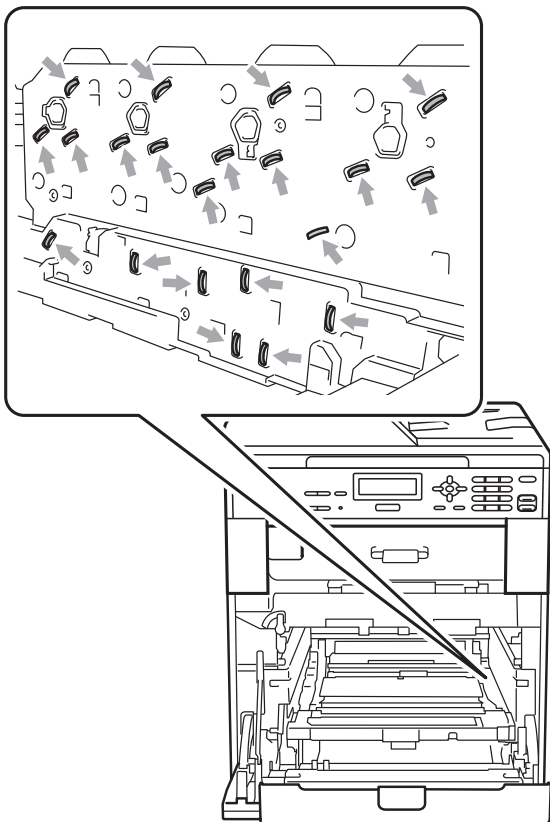

- Hold the green handles of the drum unit when you carry it. DO NOT hold the side of the drum unit.

- 5 Hold the handle of the toner cartridge and slightly push it to unlock it. Then pull it out of the drum unit. Repeat this for all the toner cartridges.

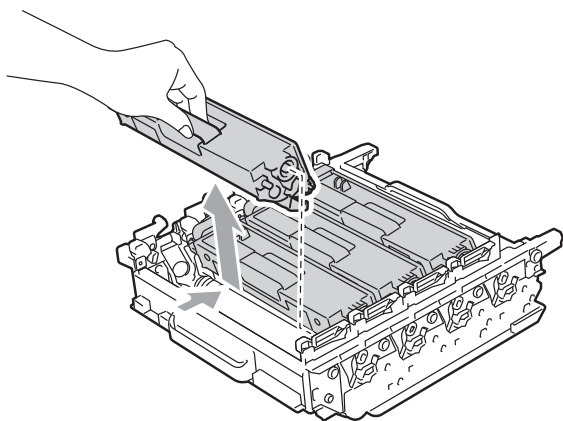

⚠ WARNING

DO NOT put a toner cartridge into a fire. It could explode, resulting in injuries.

DO NOT use cleaning materials that contain ammonia, alcohol, any type of spray, or any type of flammable substance to clean the outside or inside of the machine. Doing this may cause a fire or electrical shock.

See *To use the product safely* in the *Safety and Legal Booklet* for how to clean the machine.



Be careful not to inhale toner.

⚠ IMPORTANT

- Handle the toner cartridge carefully. If toner scatters on your hands or clothes, wipe or wash it off with cold water at once.
- We recommend that you place the drum unit and/or the toner cartridge on a clean, flat surface with a sheet of disposable paper or cloth underneath it in case you accidentally spill or scatter toner.

- To avoid print quality problems, DO NOT touch the shaded parts shown in the illustrations.

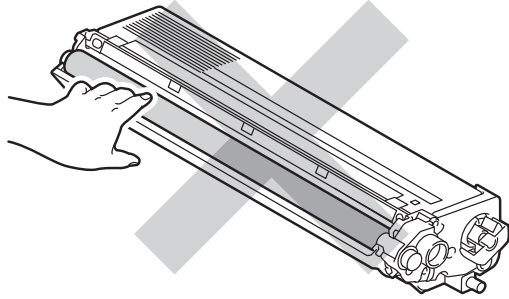

 **Note**

- Be sure to seal up the used drum unit tightly in a bag so that toner powder does not spill out of the unit.
- If you choose not to return your used consumable, please discard the used consumable according to local regulations, keeping it separate from domestic waste. If you have questions, call your local waste disposal office.

6. Unpack the new drum unit and remove the protective cover.

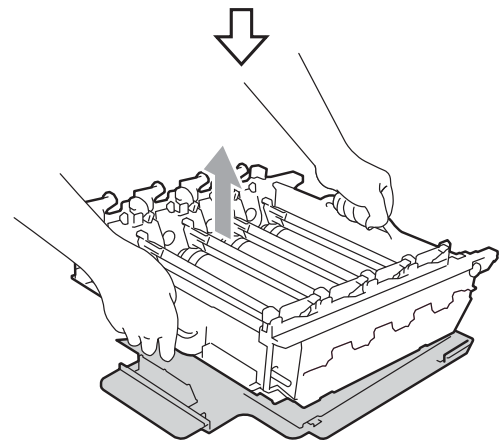
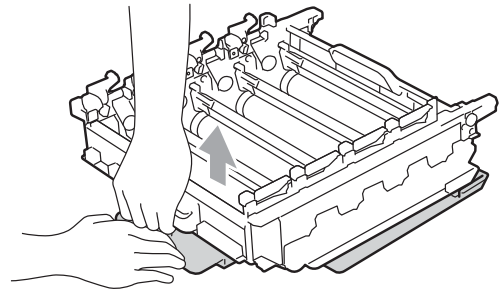

! IMPORTANT

- To avoid print quality problems, DO NOT touch the shaded parts shown in the illustrations.

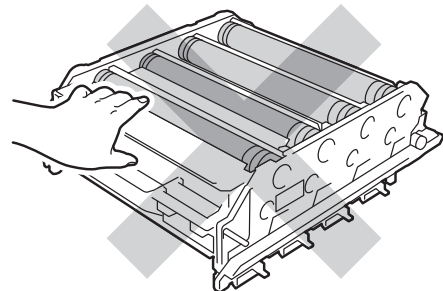
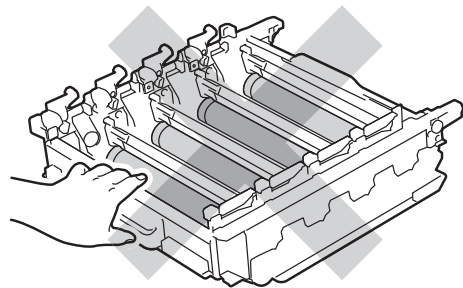

- Unpack the drum unit just before you put it in the machine. Exposure to direct sunlight or room light may damage the drum unit.

- 7 Hold the handle of the toner cartridge and slide the toner cartridge into the new unit, then slightly pull it toward you until you hear it click into place. Make sure that you match the toner cartridge color to the same color label on the drum unit. Repeat this for all the toner cartridges.

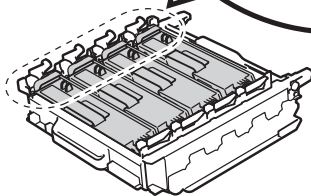
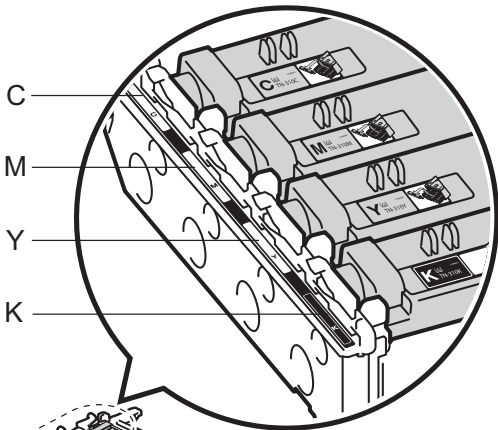
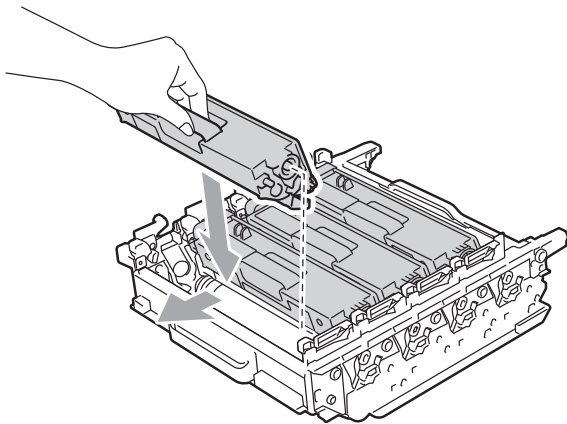

C - Cyan M - Magenta
Y - Yellow K - Black

- 8 Make sure the green lock lever (1) is in the release position as shown in the illustration.

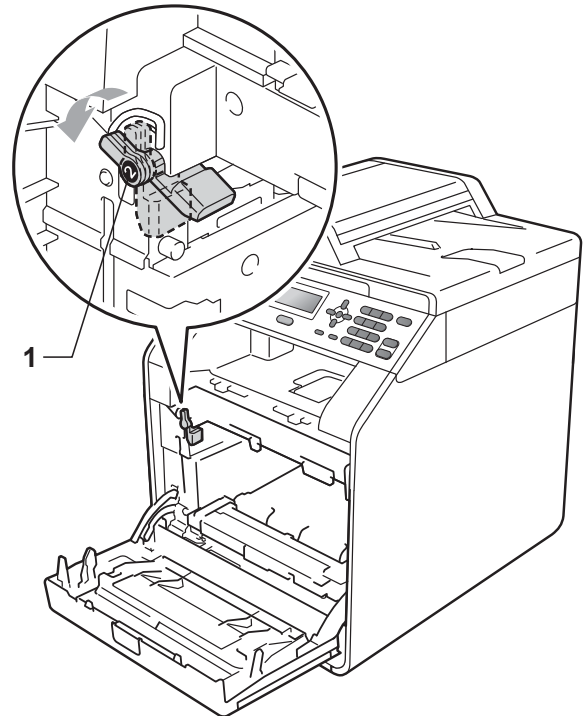

- 9 Match the guide ends (2) of the drum unit to the ► marks (1) on both sides of the machine, then gently slide the drum unit into the machine until it stops at the green lock lever.

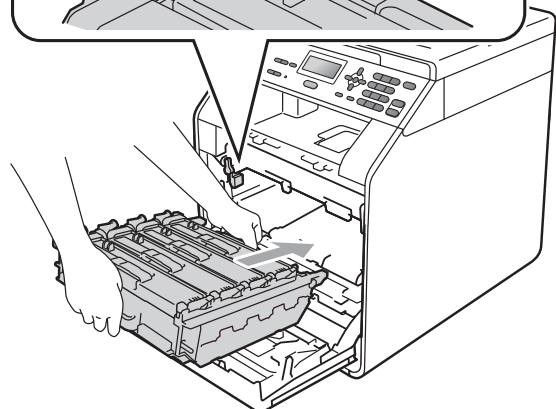
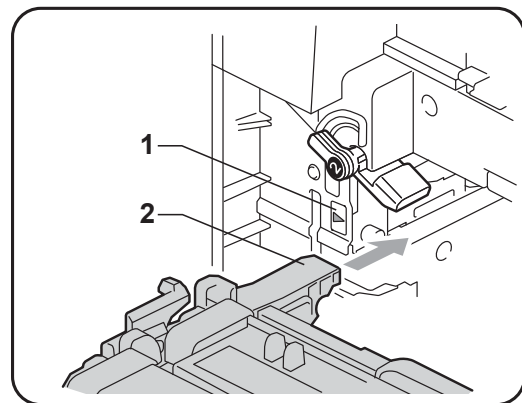

- 10 Turn the green lock lever (1) clockwise to the lock position.

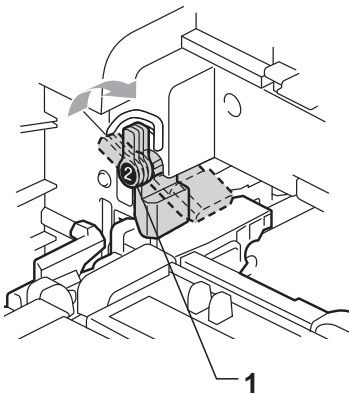

- 11 Push the drum unit in until it stops.

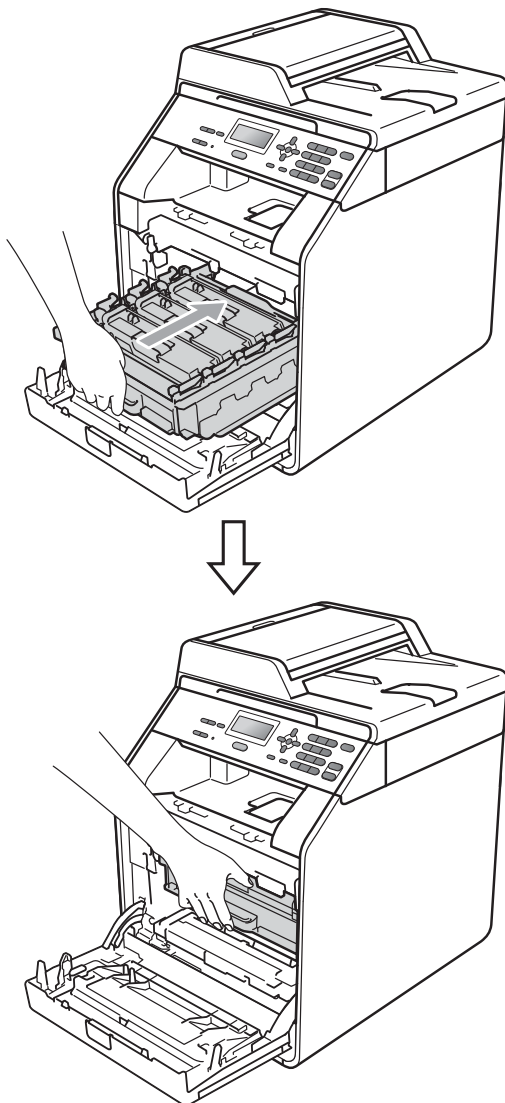

- 12 Close the front cover of the machine.

Resetting the drum counter

When you replace a drum unit with a new one, you need to reset the drum counter by completing the following steps:

- 1 Press **Menu**, **5**, **8**.
- 2 Press **▲** or **▼** to choose **Drum**. Press **OK**.
- 3 Press **1** to reset the drum unit counter.
- 4 Press **Stop/Exit**.

Replacing the belt unit

Model name: BU-300CL

A new belt unit can print approximately 50,000 A4 or Letter size single-sided pages.

Replace Belt

When the following message appears on the LCD, you need to replace the belt unit:

Replace Parts
Belt Unit

! IMPORTANT

- DO NOT touch the surface of the belt unit. If you touch it, it could degrade print quality.
- Damage caused by incorrect handling of the belt unit may void your warranty.

- 1 Make sure that the machine is turned on.

- 2 Press the front cover release button and then open the front cover.

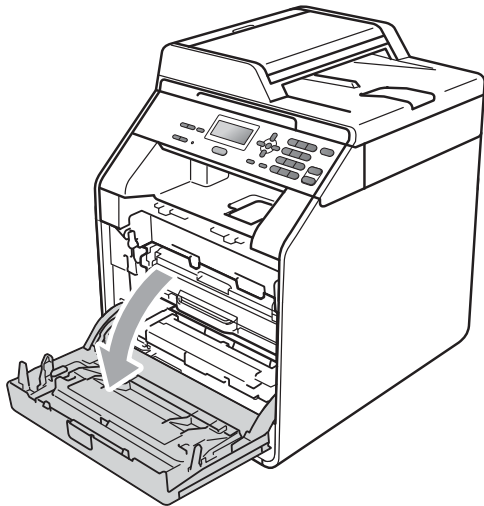
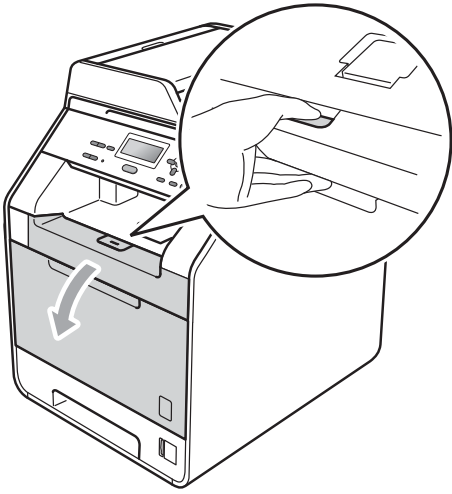

- 3 Hold the green handle of the drum unit. Pull the drum unit out until it stops.

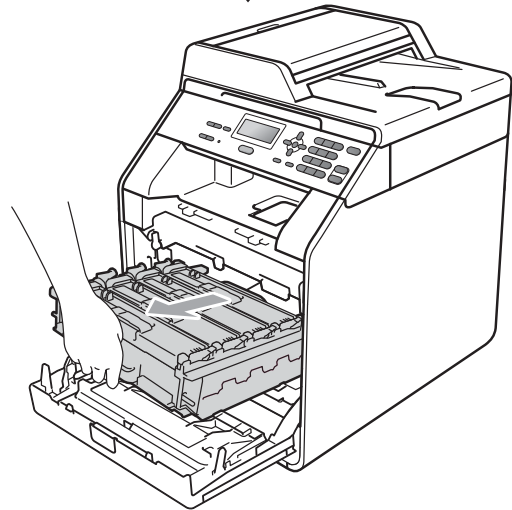
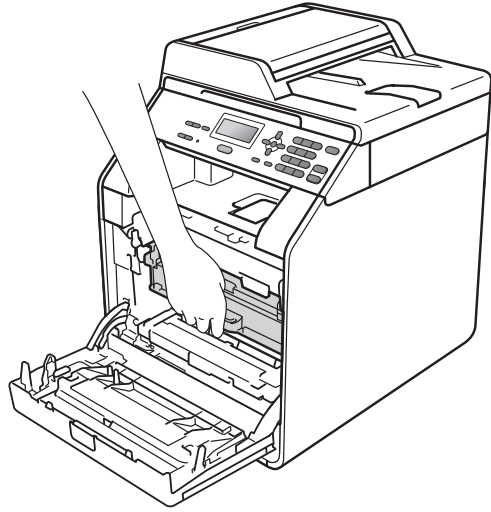

- 4 Turn the green lock lever (1) at the left of the machine anticlockwise to the release position. Holding the green handles of the drum unit, lift the front of the drum unit and remove it from the machine.

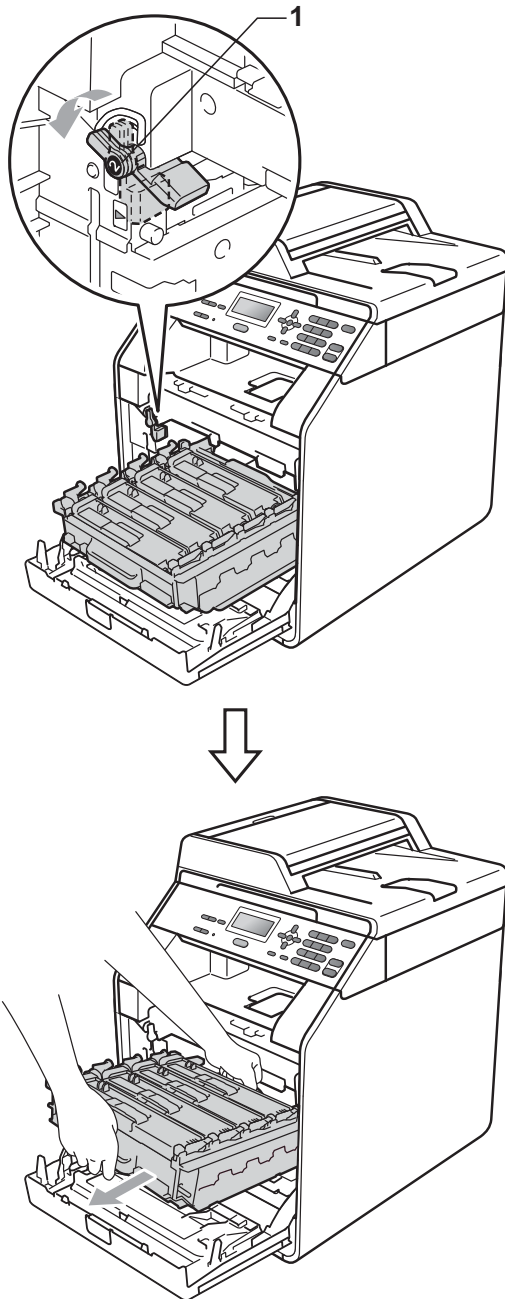

- To prevent damage to the machine from static electricity, DO NOT touch the electrodes shown in the illustration.

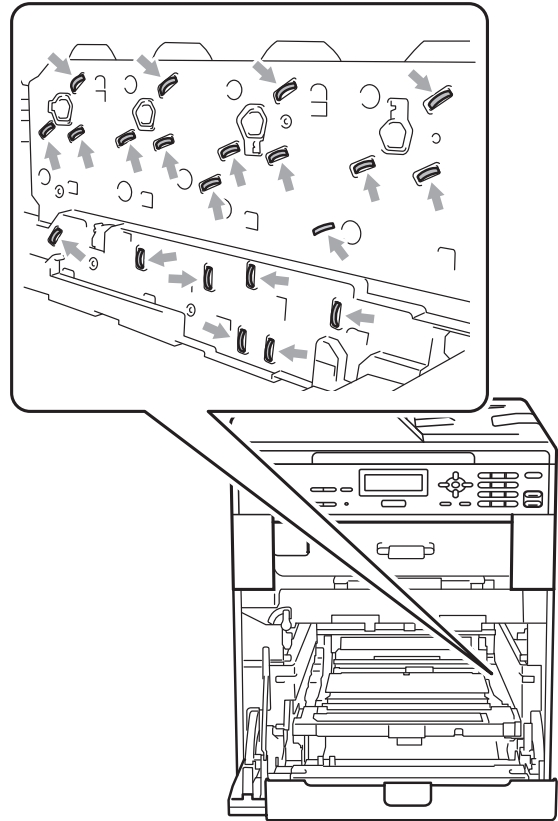

A

- Hold the green handles of the drum unit when you carry it. DO NOT hold the side of the drum unit.
- To avoid print quality problems, DO NOT touch the shaded parts shown in the illustrations.

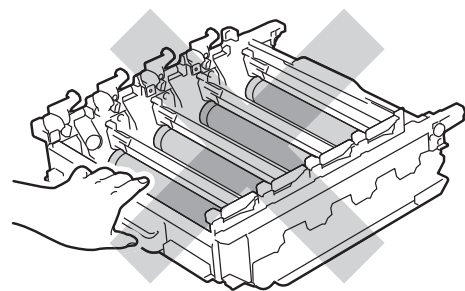

! IMPORTANT

- We recommend that you place the drum unit and/or the toner cartridge on a clean, flat surface with a sheet of disposable paper or cloth underneath it in case you accidentally spill or scatter toner.

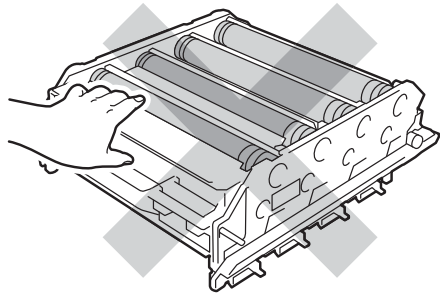

- 5 Hold the green handle of the belt unit with both hands and lift the belt unit up, then pull it out.

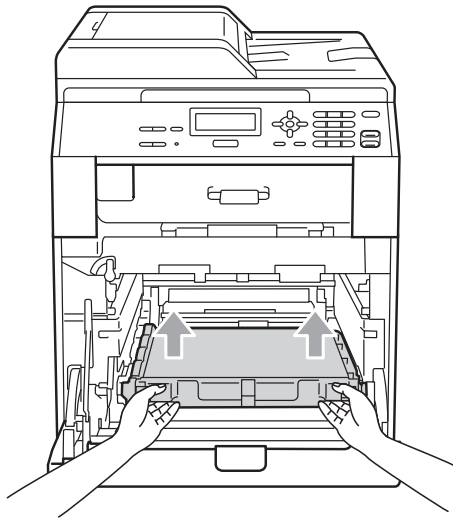

! IMPORTANT

To avoid print quality problems, DO NOT touch the shaded parts shown in the illustration.

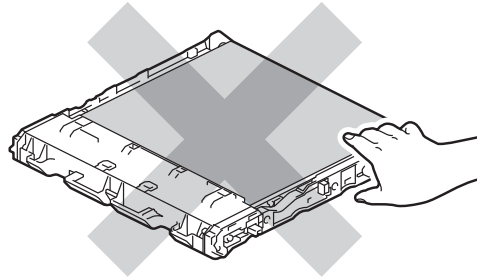
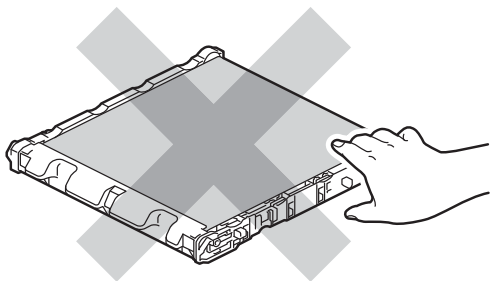

- 6 Unpack the new belt unit.
- 7 Put the new belt unit back in the machine. Make sure the belt unit is level and fits firmly into place.

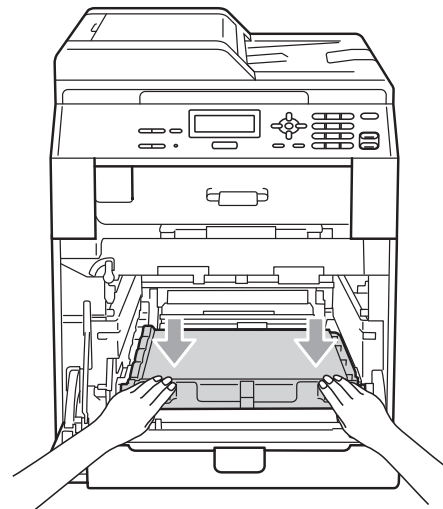
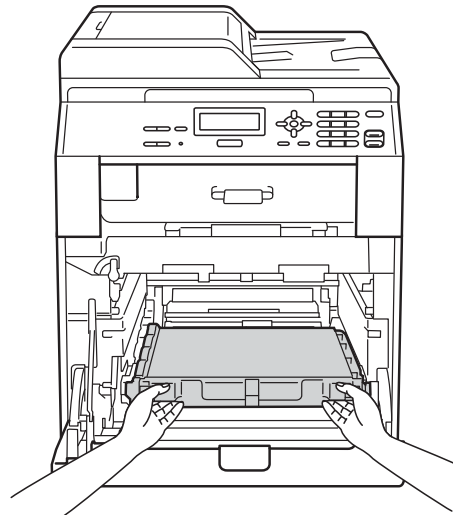

- 8 Make sure the green lock lever (1) is in the release position as shown in the illustration.

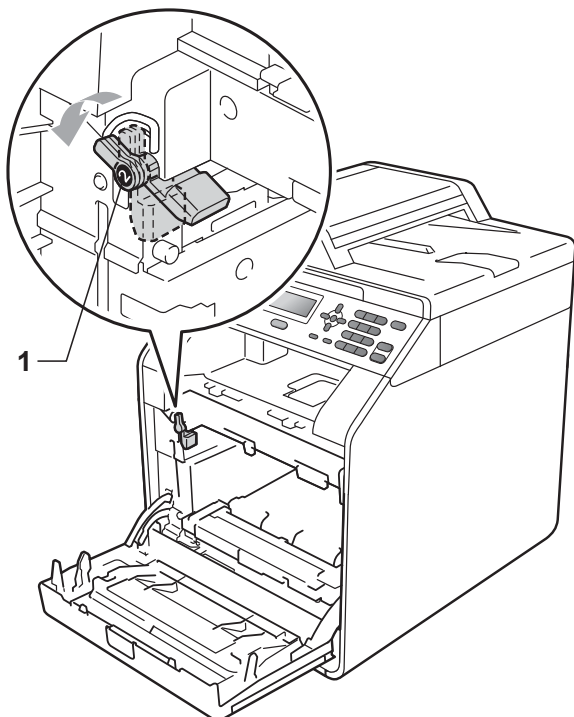

- 9 Match the guide ends (2) of the drum unit to the ► marks (1) on both sides of the machine, then gently slide the drum unit into the machine until it stops at the green lock lever.

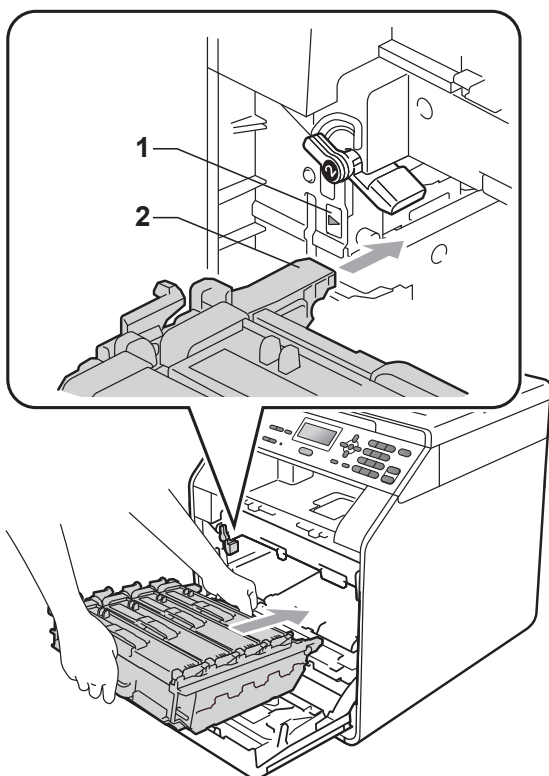

- 10 Turn the green lock lever (1) clockwise to the lock position.

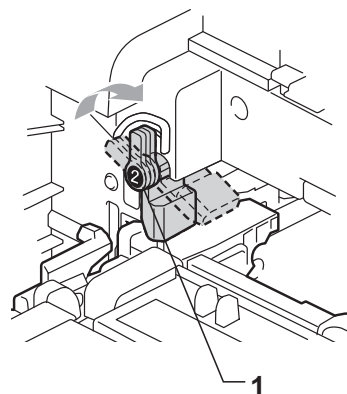

- 11 Push the drum unit in until it stops.

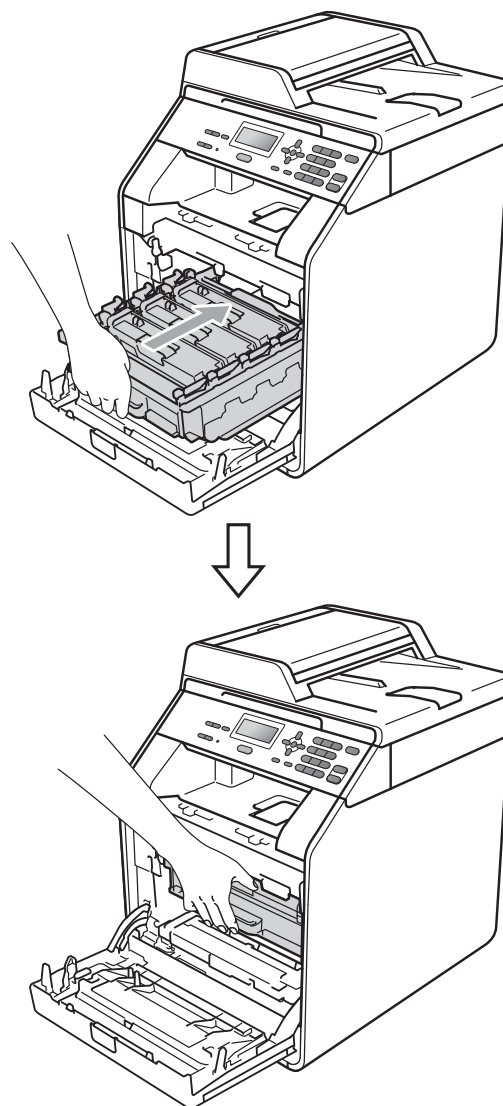

- 12 Close the front cover of the machine.

A

Resetting the belt unit counter

When you replace a belt unit with a new one, you need to reset the belt unit counter by completing the following steps:

- 1 Press **Menu**, **5**, **8**.
- 2 Press **▲** or **▼** to select `Belt Unit`. Press **OK**.
- 3 Press **1** to reset the belt unit counter.
- 4 Press **Stop/Exit**.

Replacing the waste toner box

Model name: WT-300CL

A new waste toner box can print approximately 50,000 A4 or Letter size single-sided pages.

WT Box End Soon



If the LCD shows `WT Box End Soon`, it means the waste toner box is near the end of its life. Buy a new waste toner box and have it ready before you get a `Replace WT Box` message.

Replace WT Box

When the following message appears on the LCD, you need to replace the waste toner box:



⚠ WARNING

DO NOT put the waste toner box into a fire. It could explode.

Be careful not to spill the toner. DO NOT inhale or allow it to get into your eyes.

⚠ IMPORTANT

DO NOT reuse the waste toner box.

- 1 Make sure that the machine is turned on.

- 2 Press the front cover release button and then open the front cover.

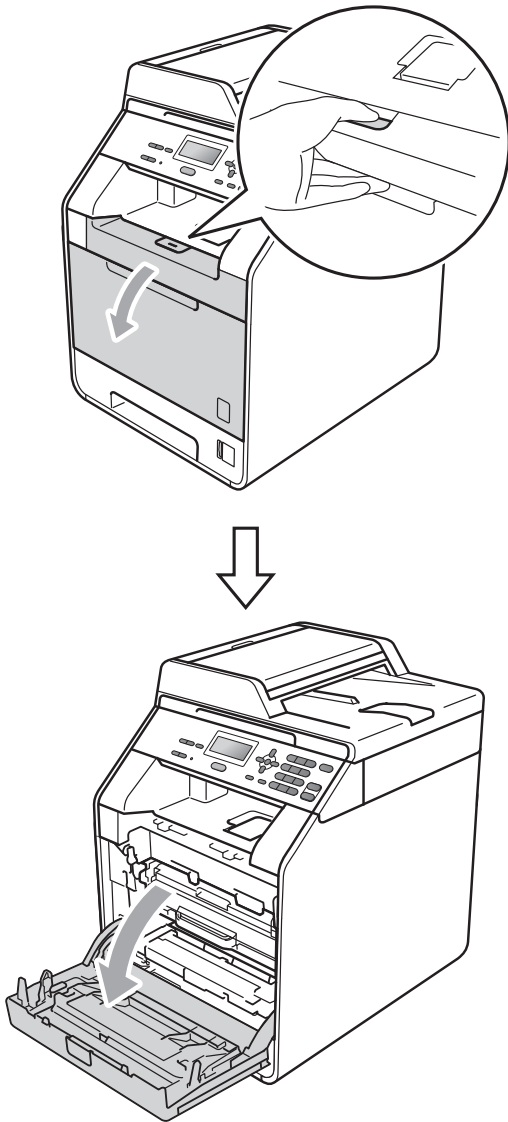

- 3 Hold the green handle of the drum unit. Pull the drum unit out until it stops.

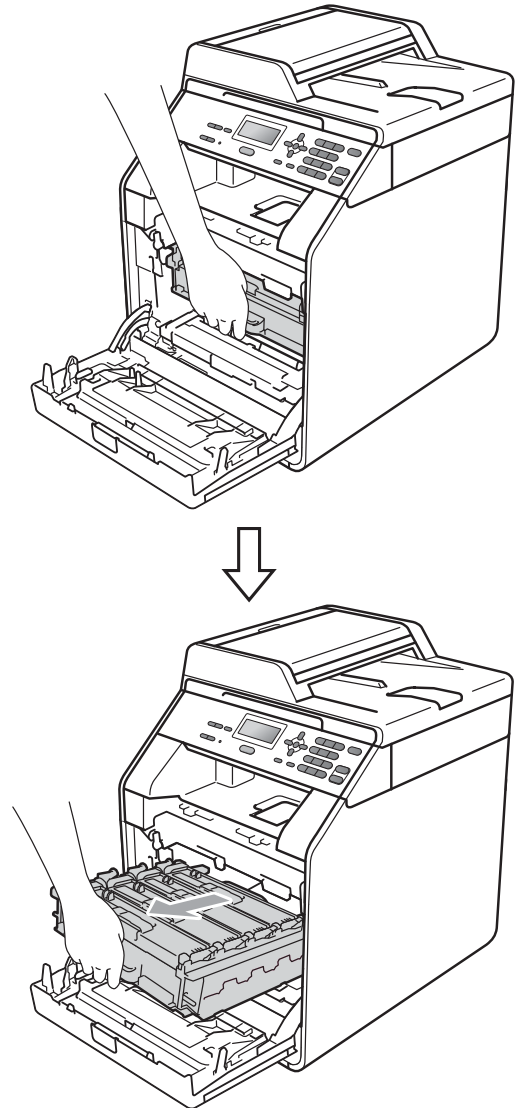

- 4 Turn the green lock lever (1) at the left of the machine anticlockwise to the release position. Holding the green handles of the drum unit, lift the front of the drum unit and remove it from the machine.

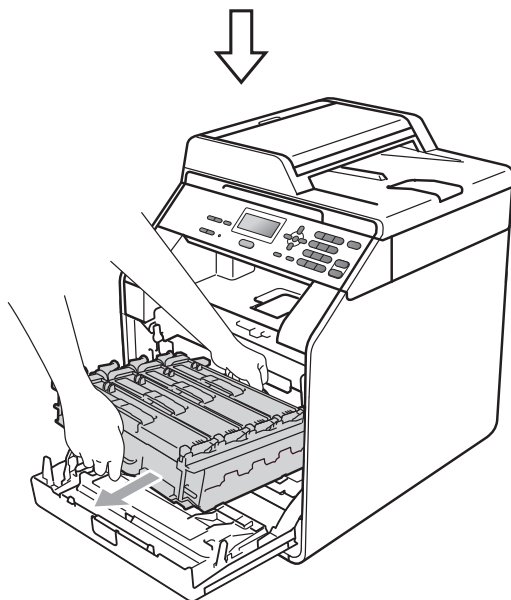
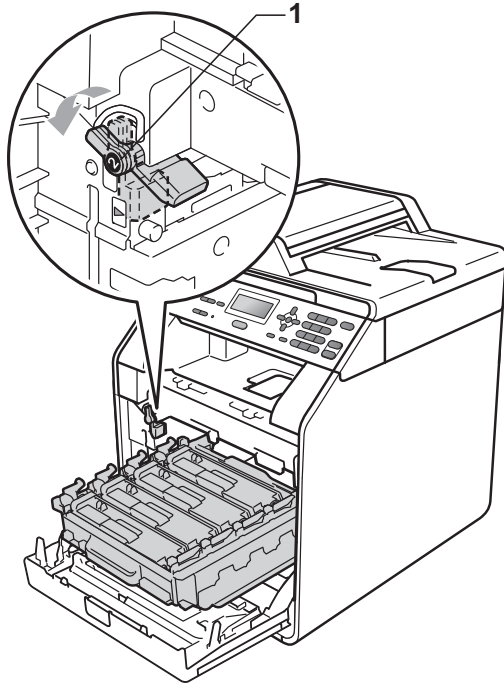

- To prevent damage to the machine from static electricity, DO NOT touch the electrodes shown in the illustration.

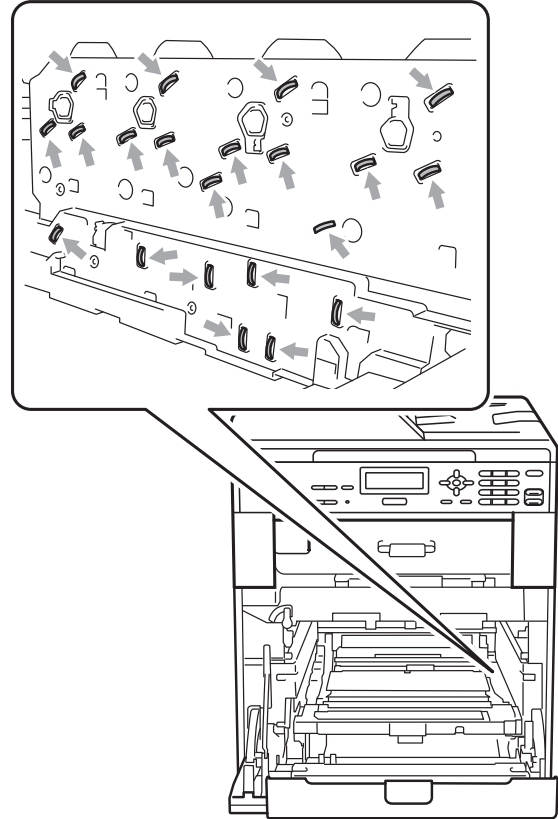

- Hold the green handles of the drum unit when you carry it. DO NOT hold the side of the drum unit.
- To avoid print quality problems, DO NOT touch the shaded parts shown in the illustrations.

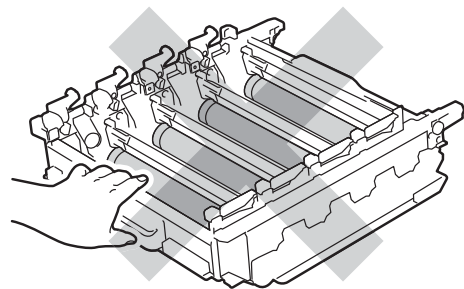

! IMPORTANT

- We recommend that you place the drum unit and/or the toner cartridge on a clean, flat surface with a sheet of disposable paper or cloth underneath it in case you accidentally spill or scatter toner.

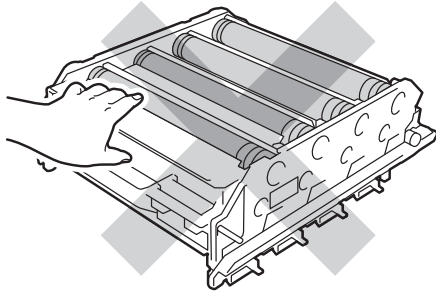

- 5 Hold the green handle of the belt unit with both hands and lift the belt unit up, then pull it out.

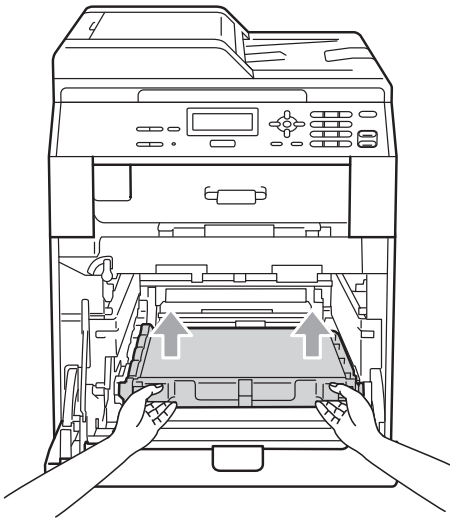

! IMPORTANT

To avoid print quality problems, DO NOT touch the shaded parts shown in the illustration.

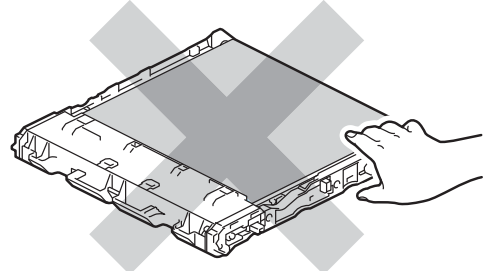
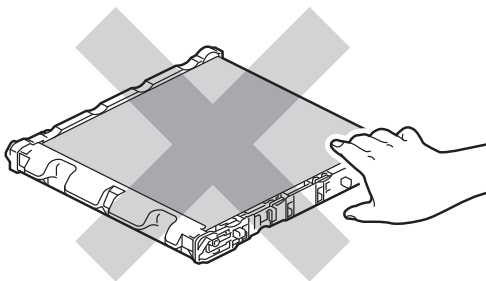

- 6 Remove two pieces of orange packing material and discard them.

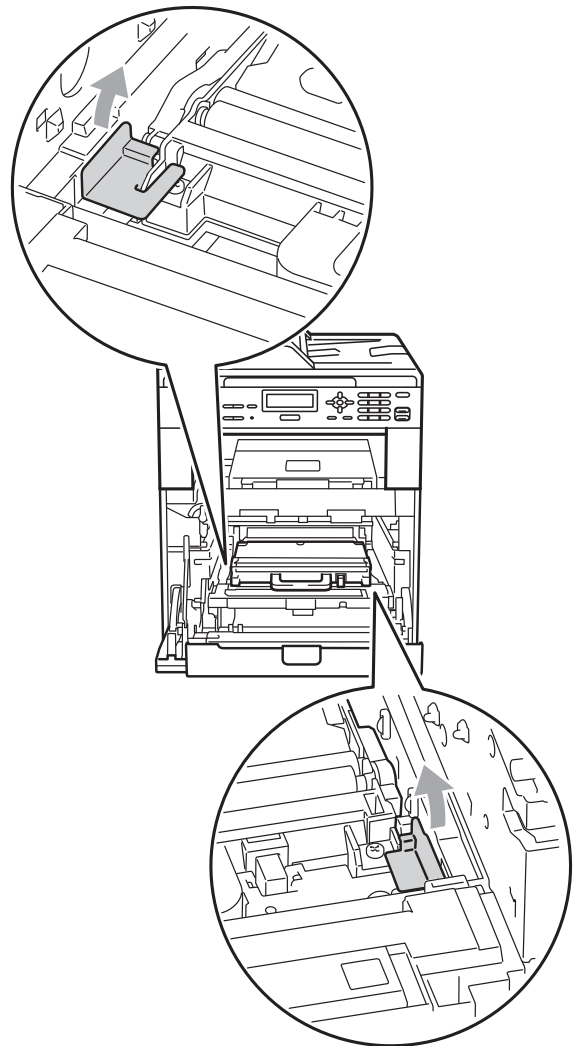

A

Note

This step is only necessary when you are replacing the waste toner box for the first time, and are not required for the replacement waste toner box. The orange packing pieces are installed at the factory to protect your machine during shipment.

- 7 Hold the green handle of the waste toner box and remove the waste toner box from the machine.

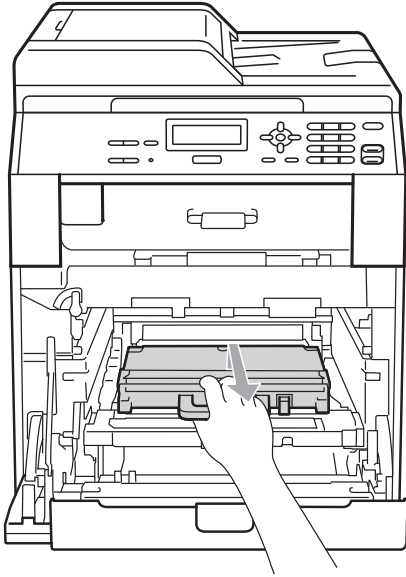

⚠ CAUTION

Handle the waste toner box carefully in case you accidentally spill or scatter toner. If toner scatters on your hands or clothes, wipe or wash it off with cold water at once.

Note

Discard the used waste toner box according to local regulations, keeping it separate from domestic waste. If you have questions, call your local waste disposal office.

- 8 Unpack the new waste toner box and put the new waste toner box in the machine using the green handle. Make sure the waste toner box is level and fits firmly into place.

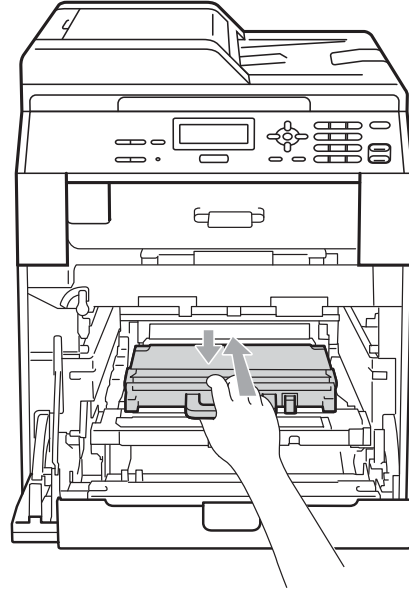

- 9 Put the belt unit back into the machine. Make sure the belt unit is level and fits firmly into place.

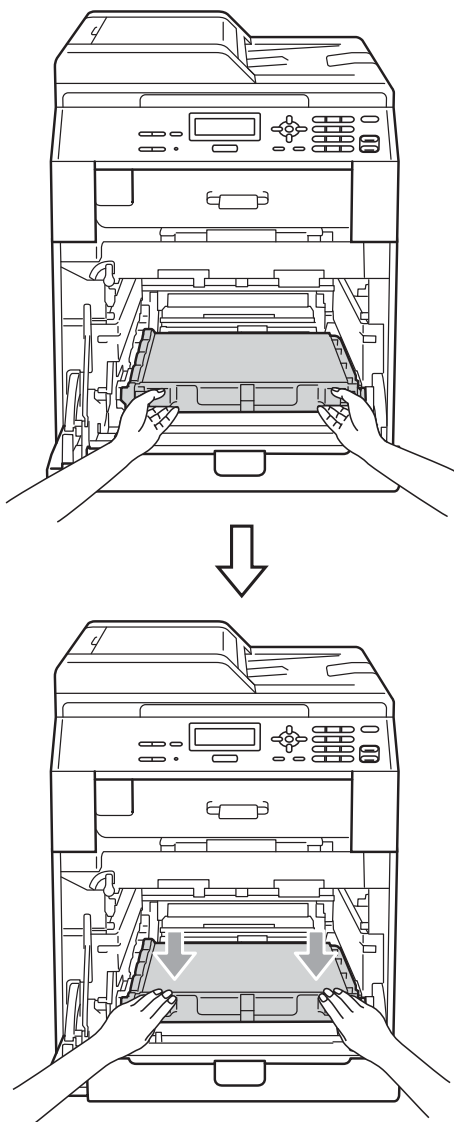

- 10 Make sure the green lock lever (1) is in the release position as shown in the illustration.

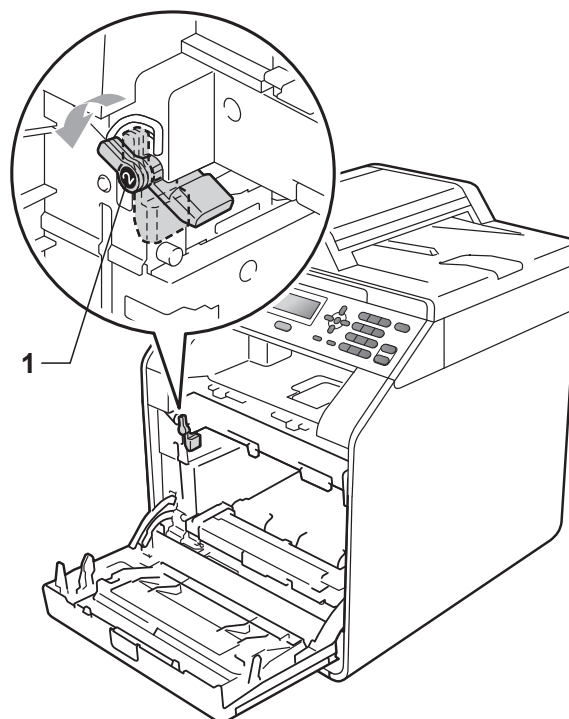

A

- 11 Match the guide ends (2) of the drum unit to the ► marks (1) on both sides of the machine, then gently slide the drum unit into the machine until it stops at the green lock lever.

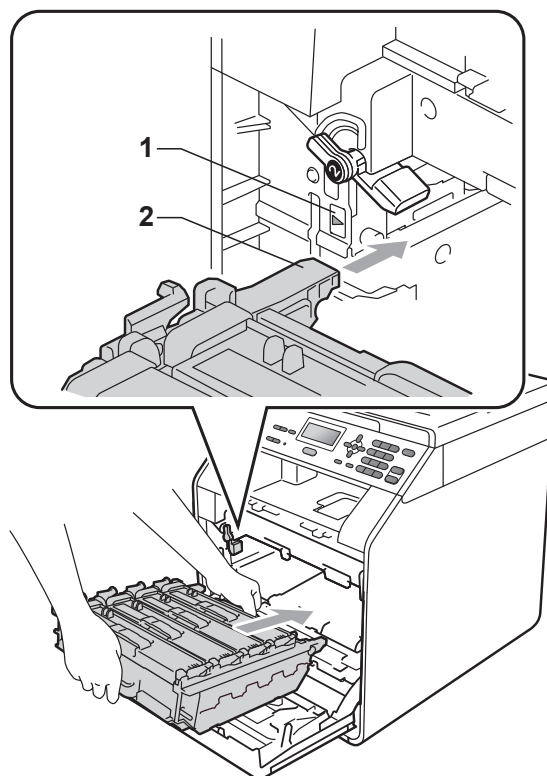

- 12 Turn the green lock lever (1) clockwise to the lock position.

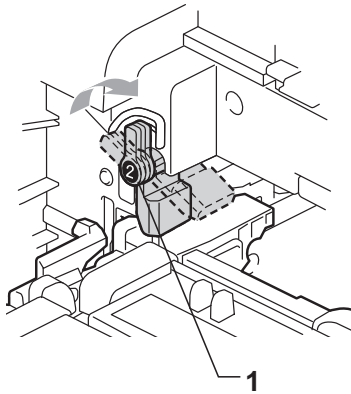

- 13 Push the drum unit in until it stops.

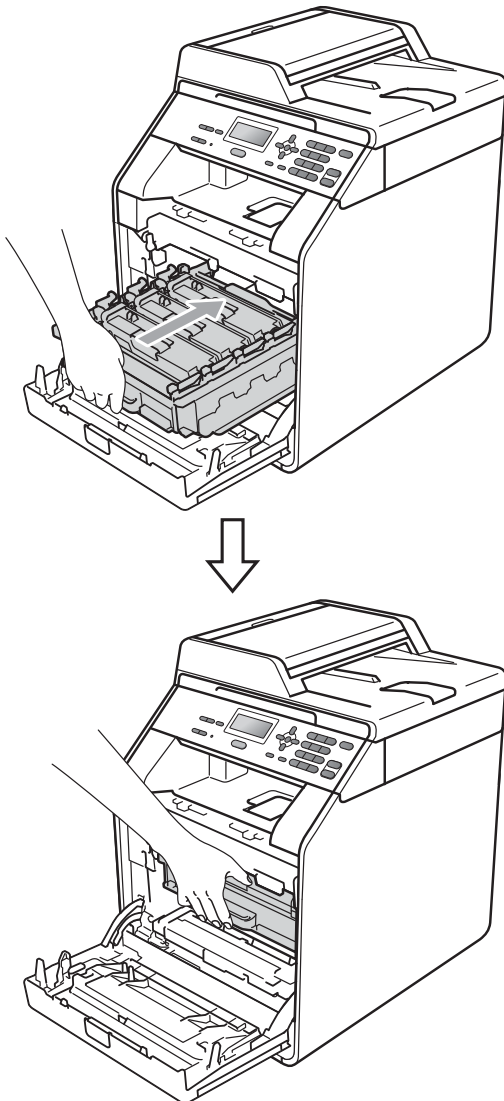

- 14 Close the front cover of the machine.

Cleaning and Checking the machine

Clean the outside and inside of the machine regularly with a dry, lint-free cloth. When you replace the toner cartridge or the drum unit, make sure that you clean the inside of the machine. If printed pages are stained with toner, clean the inside of the machine with a dry, lint-free cloth.

! WARNING

DO NOT use any flammable substances, spray or organic solvent/liquids containing alcohol/ammonia to clean the inside or outside of the machine. Doing this may cause a fire or electrical shock.



Be careful not to inhale toner.

! IMPORTANT

Use neutral detergents. Cleaning with volatile liquids such as thinner or benzene will damage the surface of the machine.

Cleaning the outside of the machine

- 1 Turn off the machine. Disconnect all cables, and then unplug the power cord from the electrical socket.

- 2 Pull the paper tray completely out of the machine.

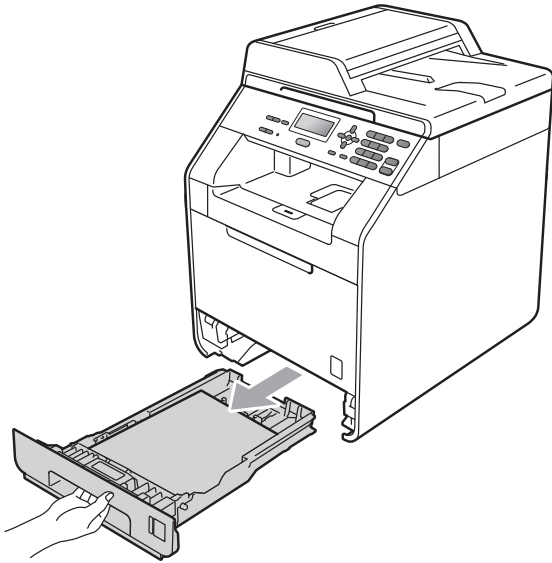

- 3 Wipe the outside of the machine with a dry, lint-free soft cloth to remove dust.

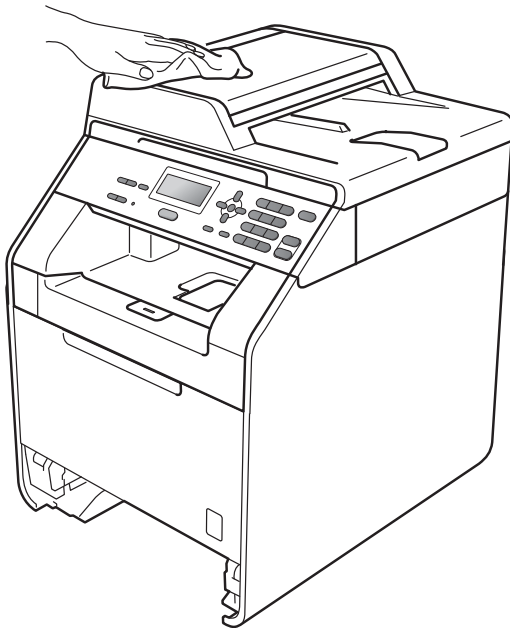

- 4 Remove any paper that is in the paper tray.

- 5 Wipe the inside and the outside of the paper tray with a dry, lint-free soft cloth to remove dust.

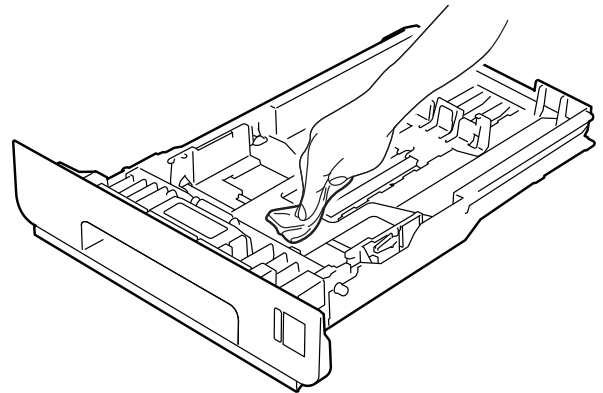

- 6 Re-load the paper and put the paper tray firmly back in the machine.
- 7 Plug the machine's power cord back into the electrical socket first, and connect all cables. Turn on the machine.

A

Cleaning the scanner glass

- 1 Turn off the machine. Disconnect all cables, and then unplug the power cord from the electrical socket.
- 2 Lift the document cover (1). Clean the white plastic surface (2) and scanner glass (3) underneath it with a soft lint-free cloth moistened with water.

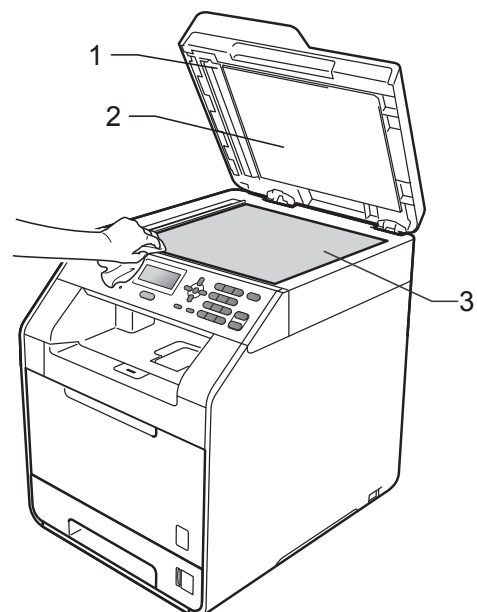

- 3 In the ADF unit, clean the white bar (1) and the scanner glass strip (2) underneath it with a soft lint-free cloth moistened with water.

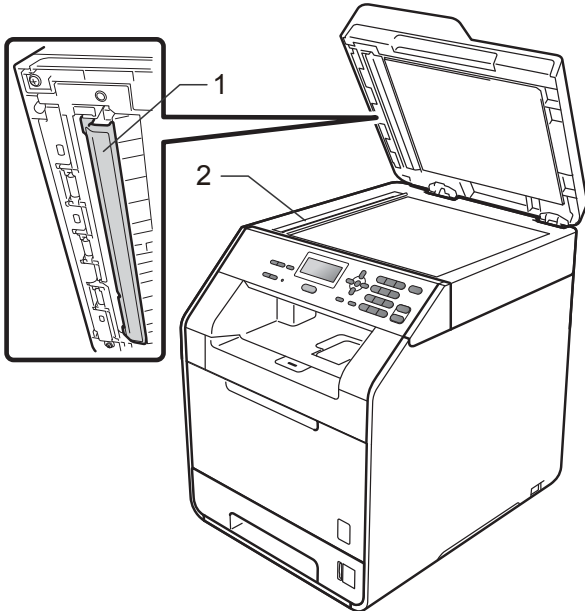

 **Note**

In addition to cleaning the scanner glass and glass strip with a soft lint-free cloth moistened with water, run your finger tip over the glass to see if you can feel anything on it. If you feel dirt or debris, clean the glass again concentrating on that area. You may need to repeat the cleaning process three or four times. To test, make a copy after each cleaning.

- 4 Plug the machine's power cord back into the electrical socket first, and connect all cables. Turn on the machine.

Cleaning the laser scanner windows

- 1 Turn off the machine. Disconnect all cables, and then unplug the power cord from the electrical socket.
- 2 Press the front cover release button and then open the front cover.

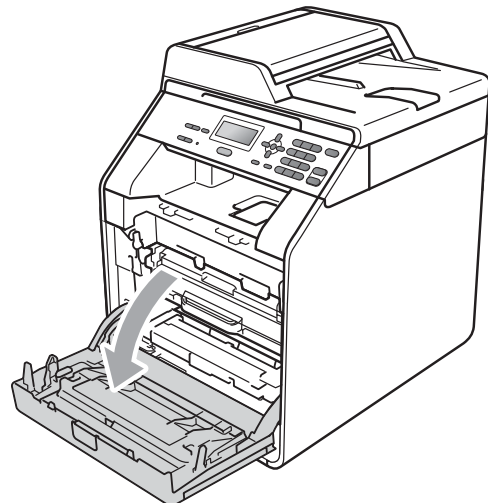
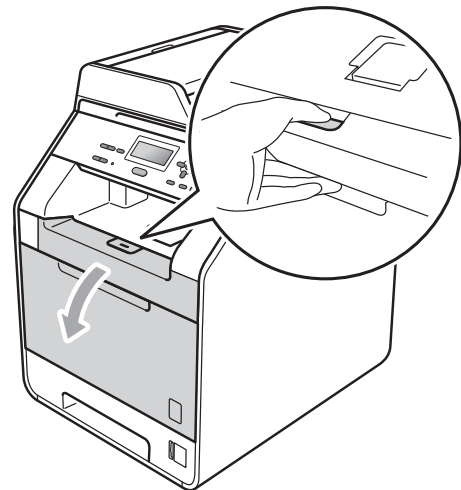

- 3 Hold the green handle of the drum unit. Pull the drum unit out until it stops.

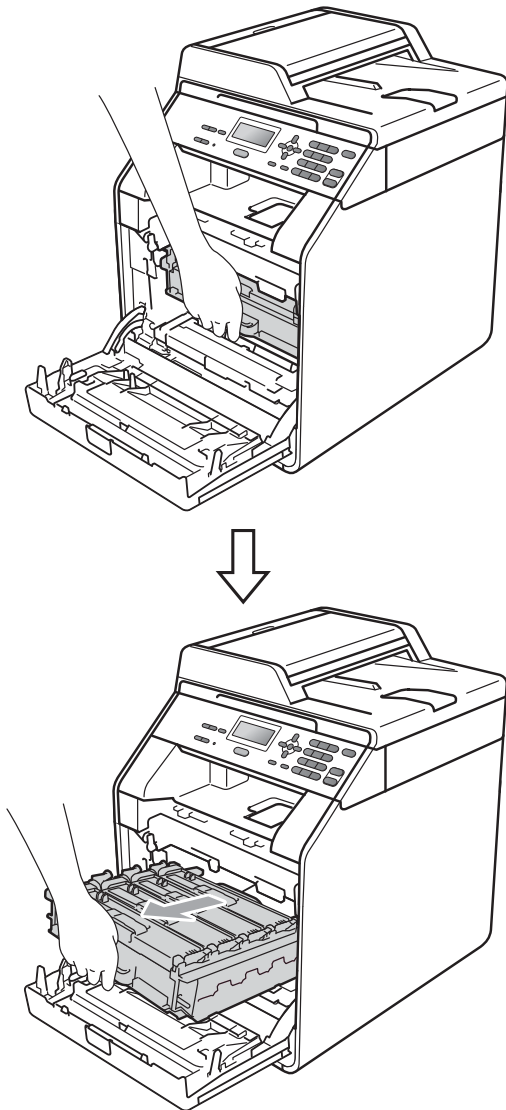

- 4 Turn the green lock lever (1) at the left of the machine anticlockwise to the release position. Holding the green handles of the drum unit, lift the front of the drum unit and remove it from the machine.

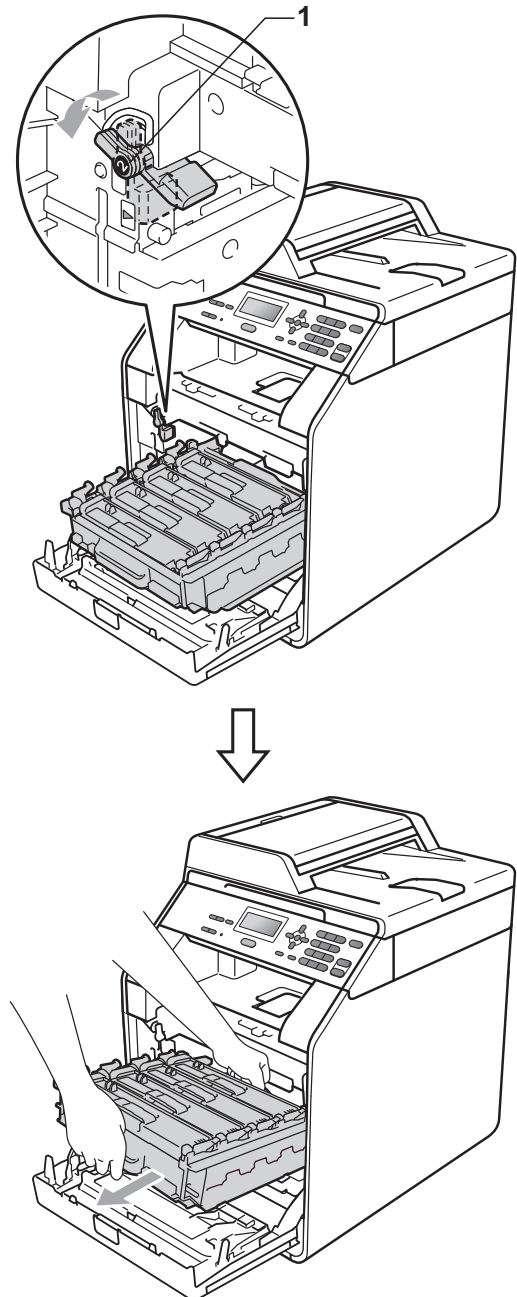

A

! IMPORTANT

- We recommend that you place the drum unit and/or the toner cartridge on a clean, flat surface with a sheet of disposable paper or cloth underneath it in case you accidentally spill or scatter toner.

- To prevent damage to the machine from static electricity, DO NOT touch the electrodes shown in the illustration.

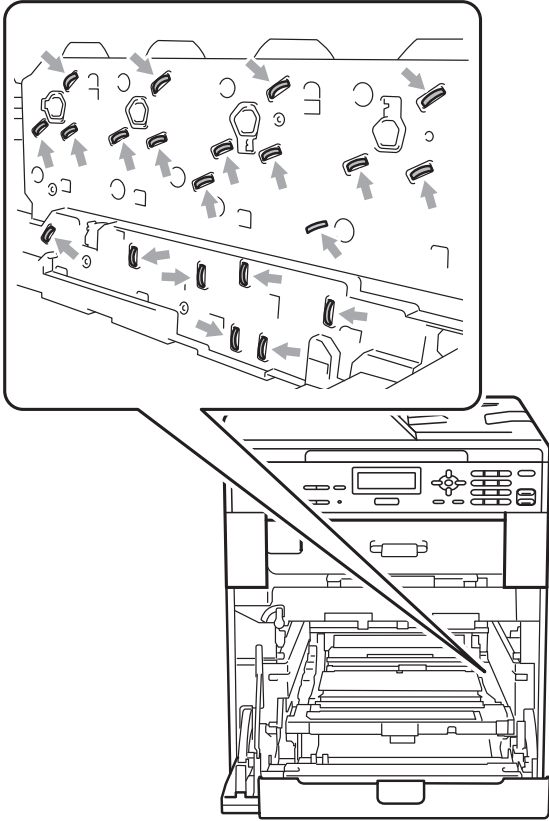

- Hold the green handles of the drum unit when you carry it. DO NOT hold the side of the drum unit.

- 5 Wipe the four scanner windows (1) with a dry, lint-free cloth.

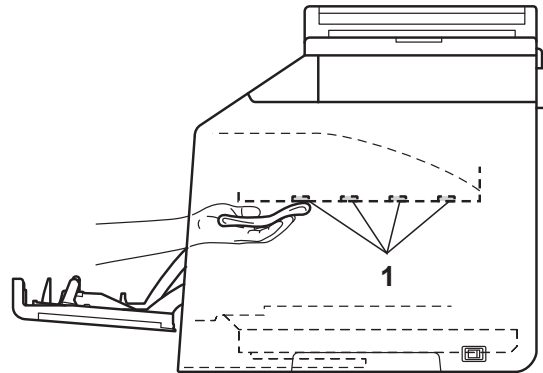
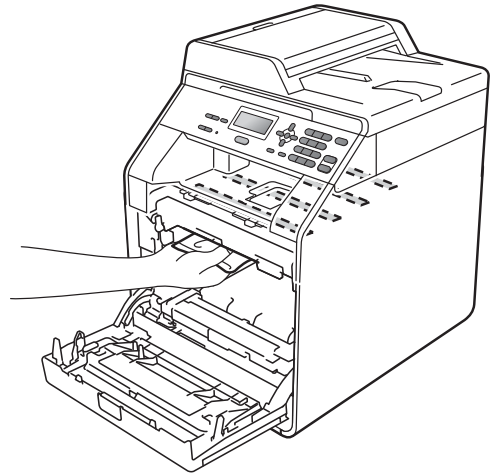

- 6 Make sure the green lock lever (1) is in the release position as shown in the illustration.

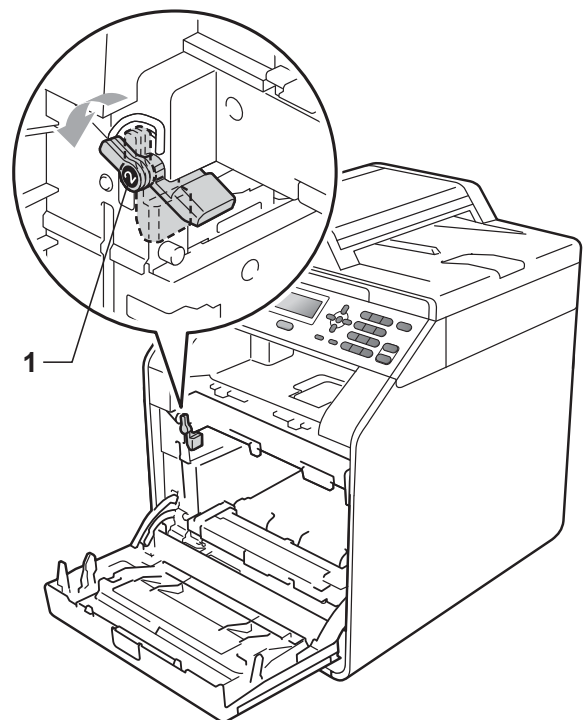

- 7 Match the guide ends (2) of the drum unit to the ► marks (1) on both sides of the machine, then gently slide the drum unit into the machine until it stops at the green lock lever.

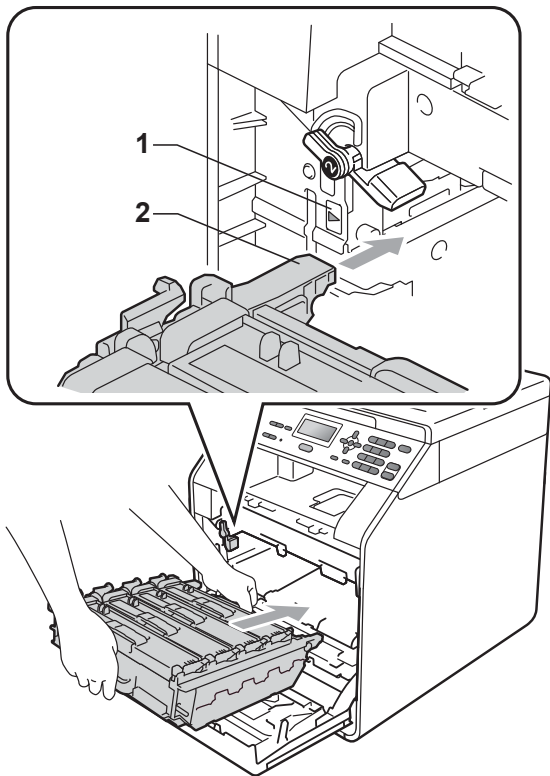

- 8 Turn the green lock lever (1) clockwise to the lock position.

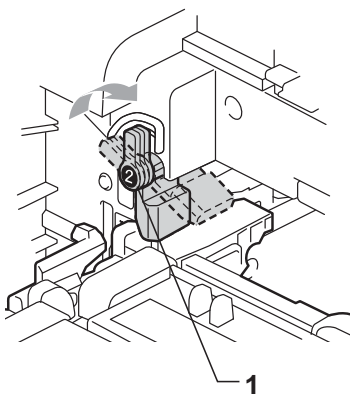

- 9 Push the drum unit in until it stops.

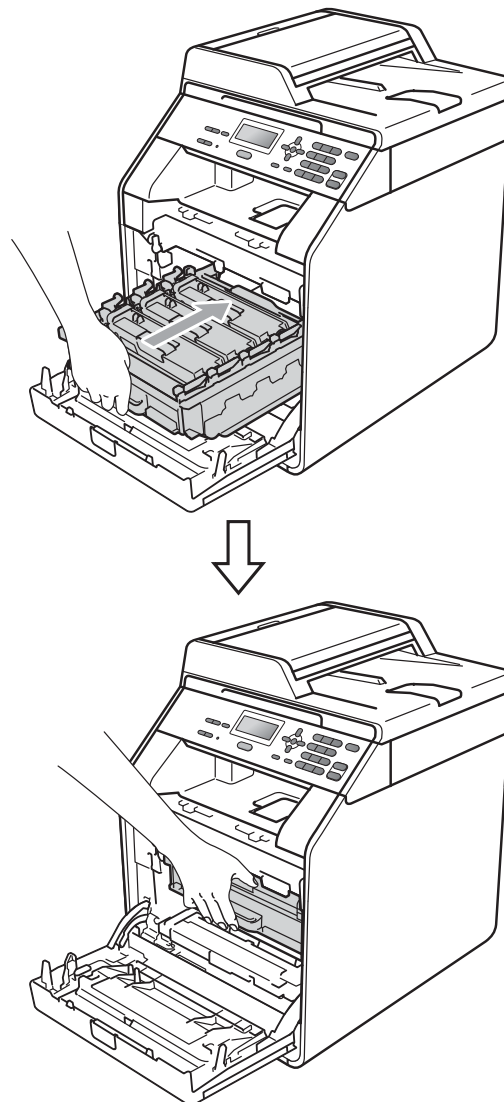

- 10 Close the front cover of the machine.

- 11 Plug the machine's power cord back into the electrical socket first, and connect all cables. Turn on the machine.

A

Cleaning the corona wires

If you have print quality problems, clean the four corona wires as follows:

- 1 Press the front cover release button and then open the front cover.

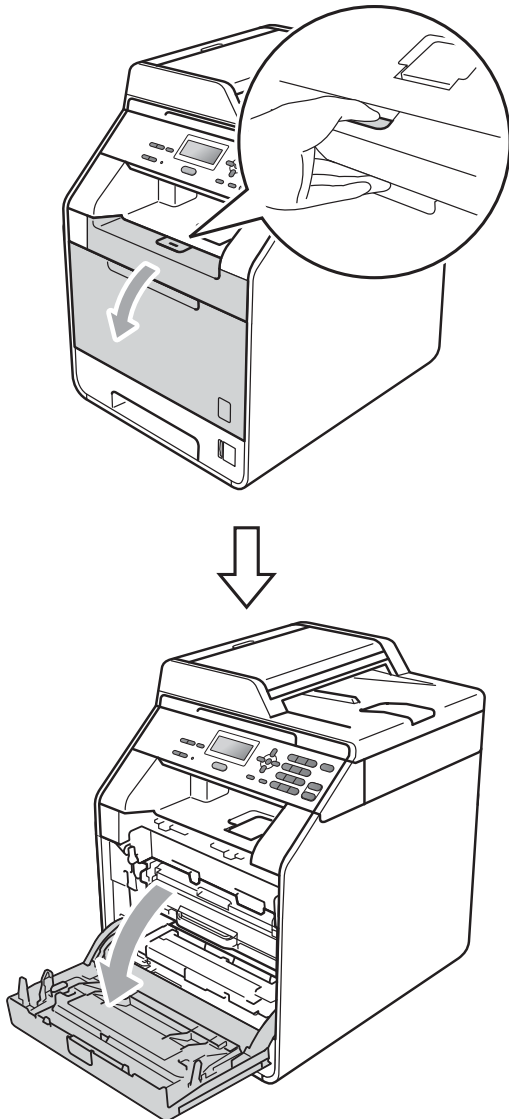

- 2 Hold the green handle of the drum unit. Pull the drum unit out until it stops.

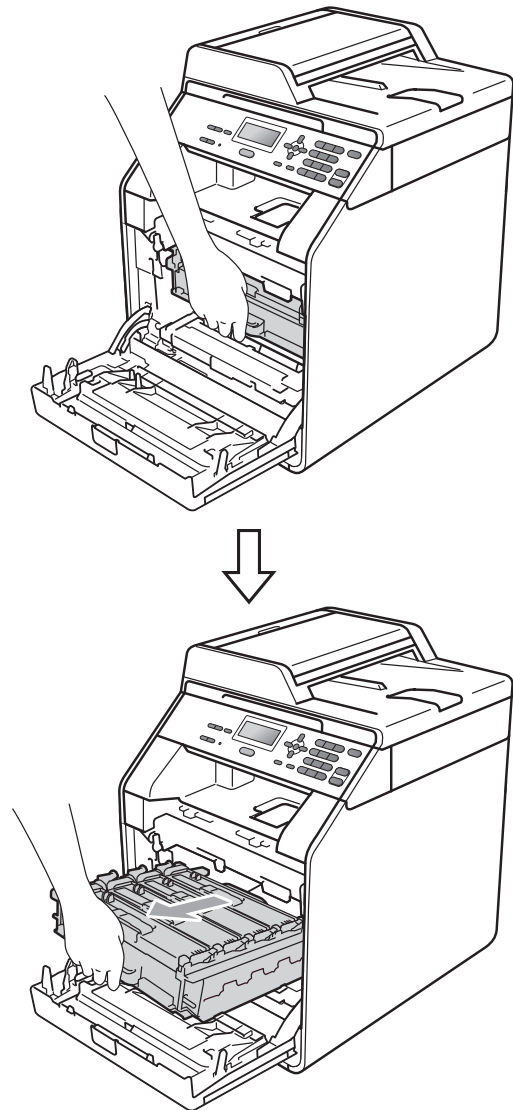

- 3 Hold the handle of the toner cartridge and slightly push it toward the machine to unlock it. Then pull it out of the drum unit. Repeat this for all the toner cartridges.

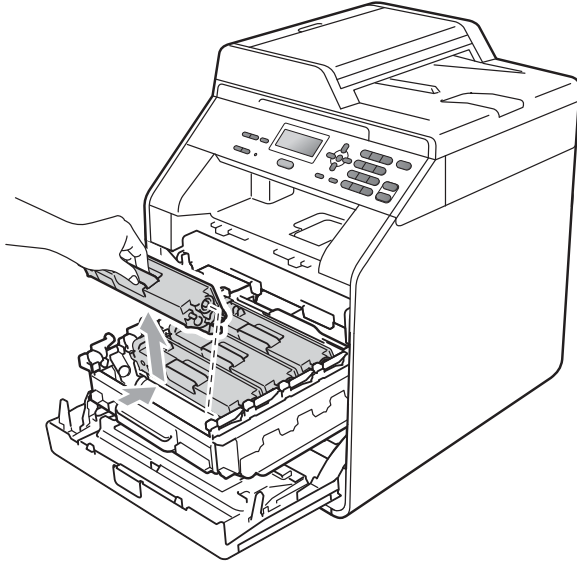

- 4 Push to release the latches of the corona wire cover (1), and then open the cover.

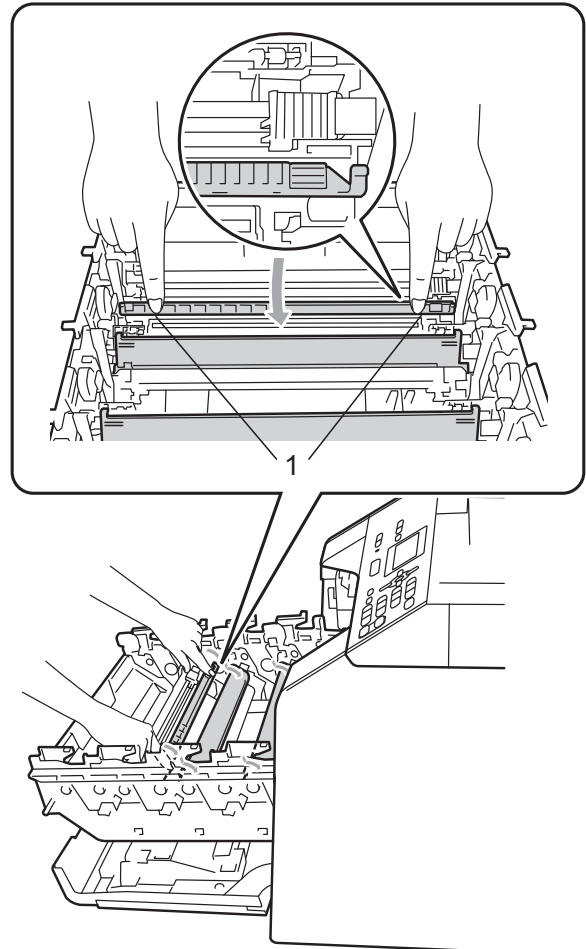

- 5 Clean the corona wire inside the drum unit by gently sliding the green tab from left to right and right to left several times.

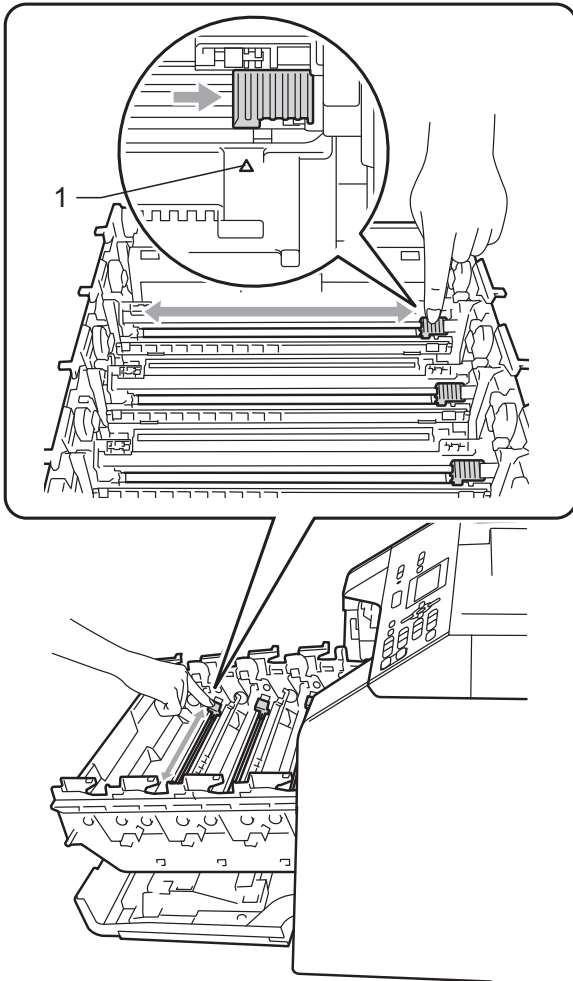

- 6 Close the corona wire cover.

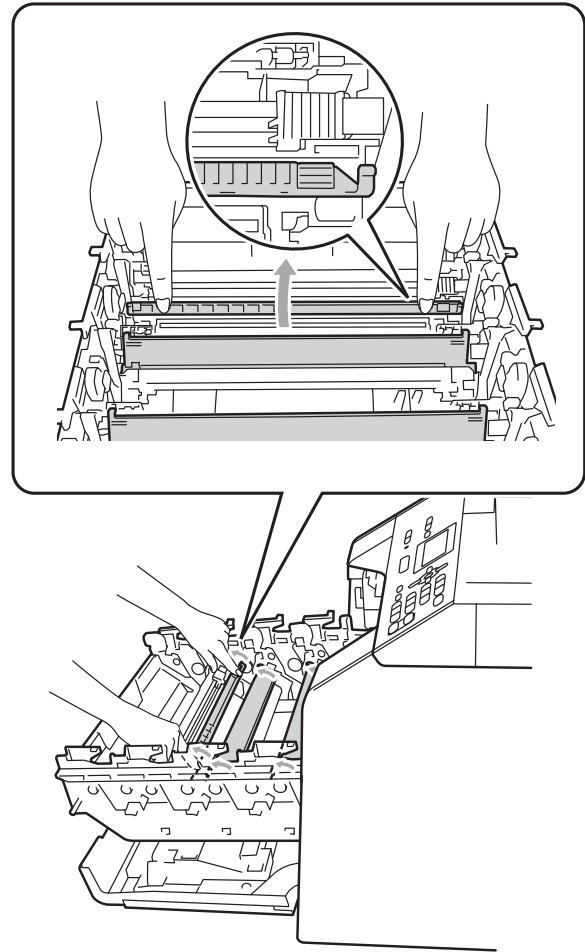

- 7 Repeat steps 4 to 6 to clean each of three remaining corona wires.

 **Note**

Be sure to return the tab to the home position (▲) (1). If you do not, printed pages may have a vertical stripe.

- 8 Hold the handle of the toner cartridge and slide the toner cartridge into the drum unit then slightly pull it toward you until you hear it click into place. Make sure that you match the toner cartridge color to the same color label on the drum unit. Repeat this for all the toner cartridges.

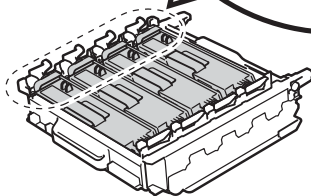
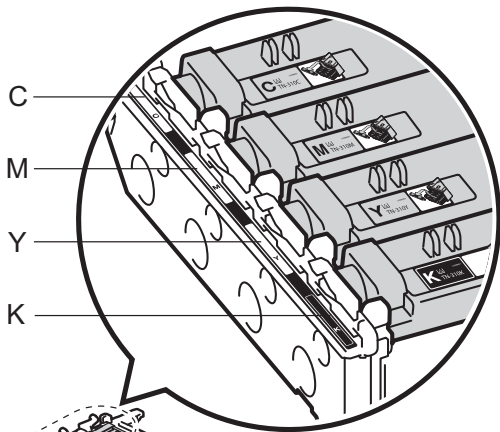
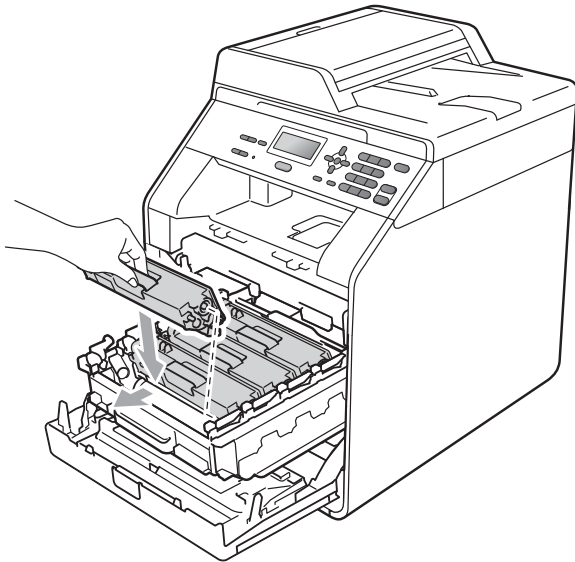

C - Cyan M - Magenta
 Y - Yellow K - Black

- 9 Push the drum unit in until it stops.

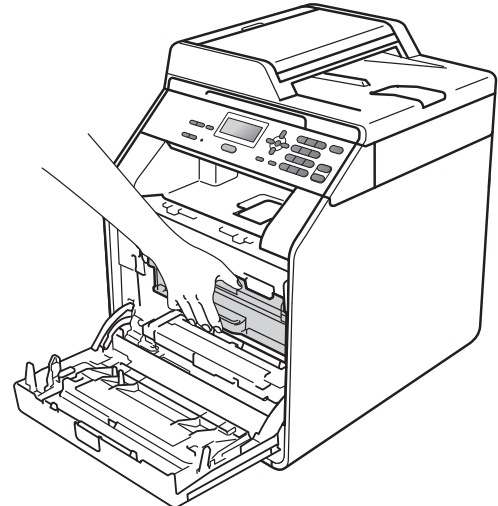
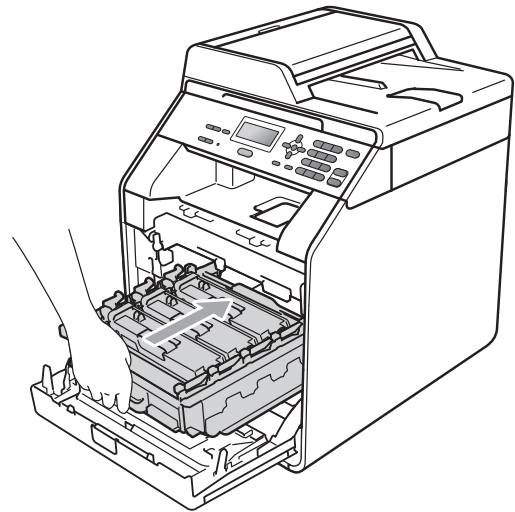

- 10 Close the front cover of the machine.

Cleaning the drum unit

If your printout has colored dots at 94 mm intervals the drum may have something stuck to the drum surface, such as glue from a label. Follow the steps below to solve the problem.

A

- 1 Make sure that the machine is in the Ready mode. Press **Menu**, **5**, **6**, then press **Mono Start** or **Color Start** to print the drum dot check sheet.

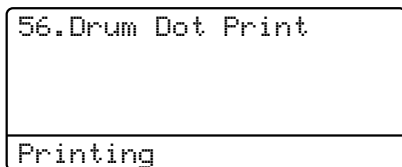

- 2 Turn off the machine. Disconnect all cables, and then unplug the power cord from the electrical socket.
- 3 Press the front cover release button and then open the front cover.

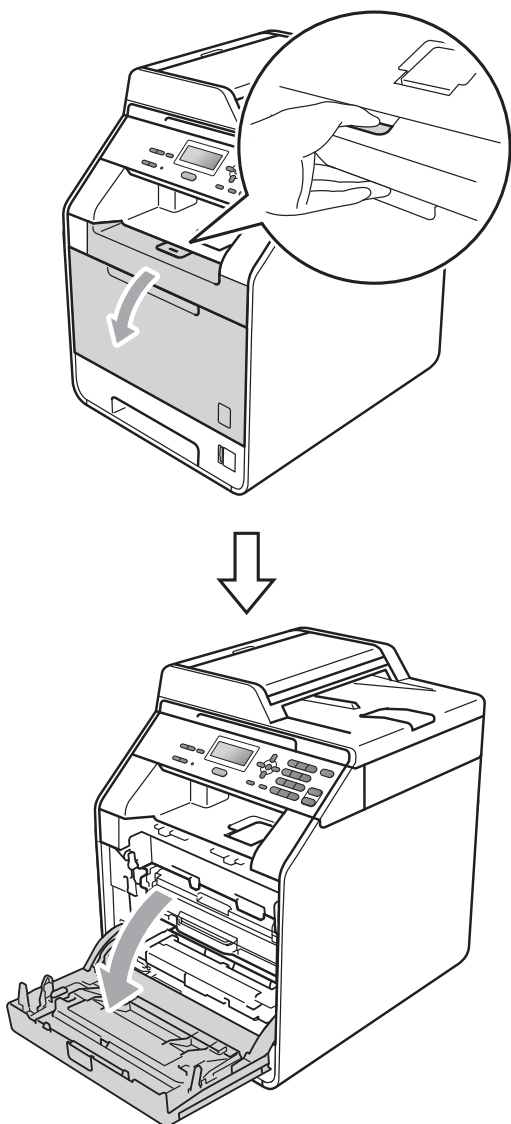

- 4 Hold the green handle of the drum unit. Pull the drum unit out until it stops.

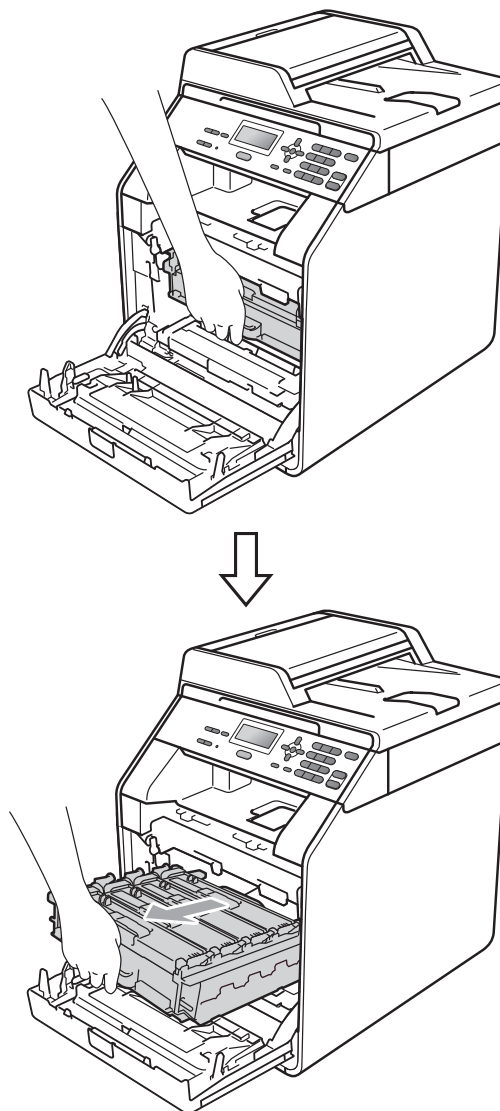

- 5 Turn the green lock lever (1) at the left of the machine anticlockwise to the release position. Holding the green handles of the drum unit, lift the front of the drum unit and remove it from the machine.

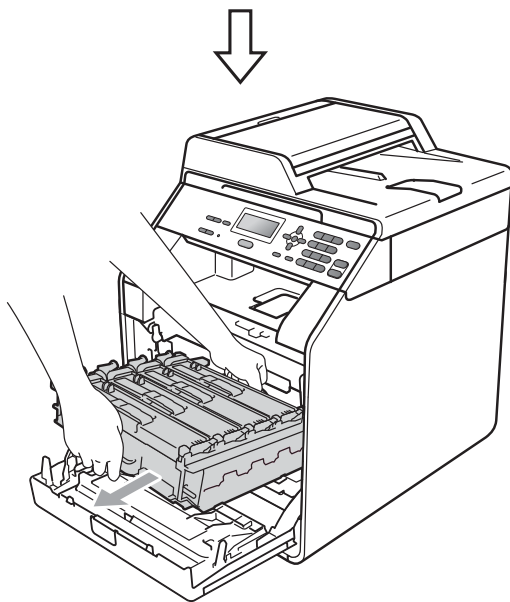
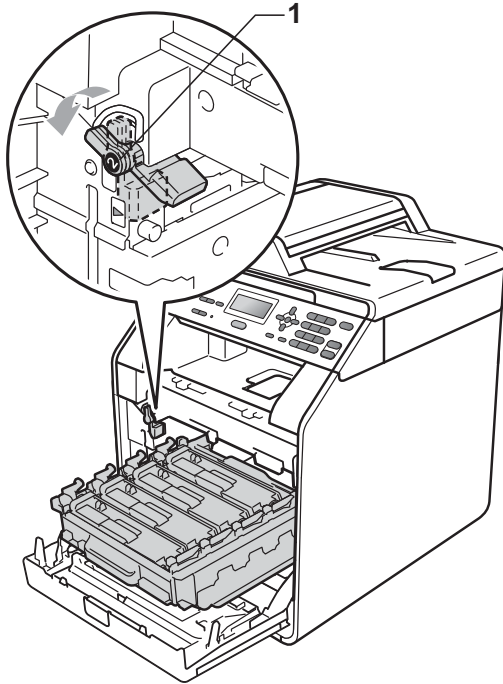

! IMPORTANT

- We recommend that you place the drum unit and/or the toner cartridge on a clean, flat surface with a sheet of disposable paper or cloth underneath it in case you accidentally spill or scatter toner.

- To prevent damage to the machine from static electricity, DO NOT touch the electrodes shown in the illustration.

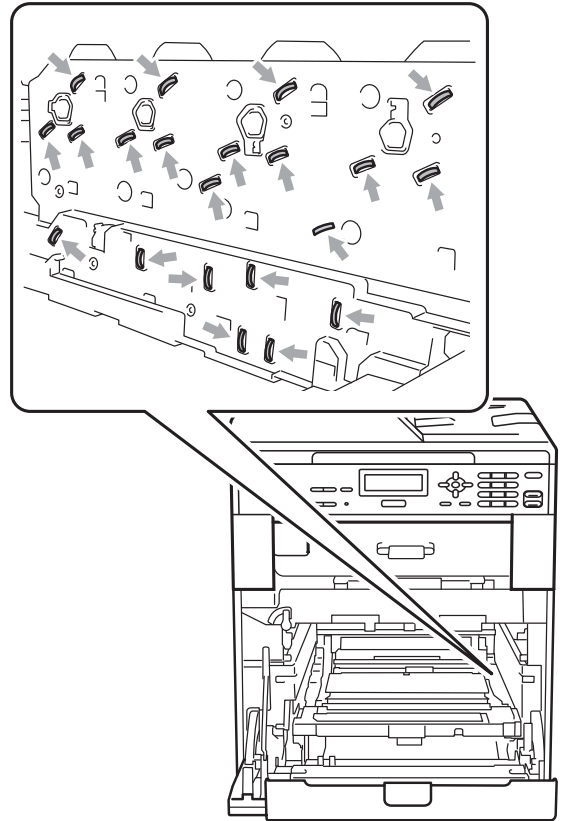

- Hold the green handles of the drum unit when you carry it. DO NOT hold the side of the drum unit.

- 6 Hold the handle of the toner cartridge and slightly push it to unlock it. Then pull it out of the drum unit. Repeat this for all the toner cartridges.

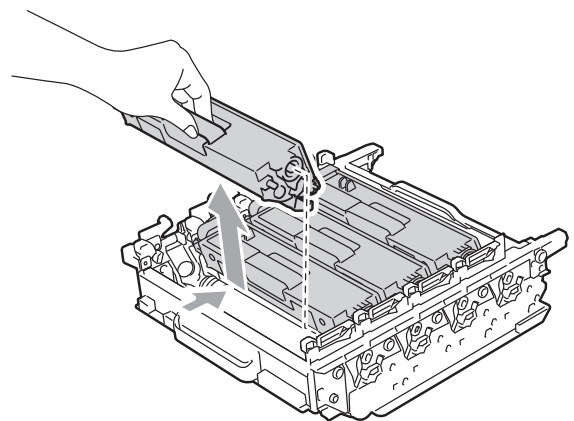

! IMPORTANT

To avoid print quality problems, DO NOT touch the shaded parts shown in the illustrations.

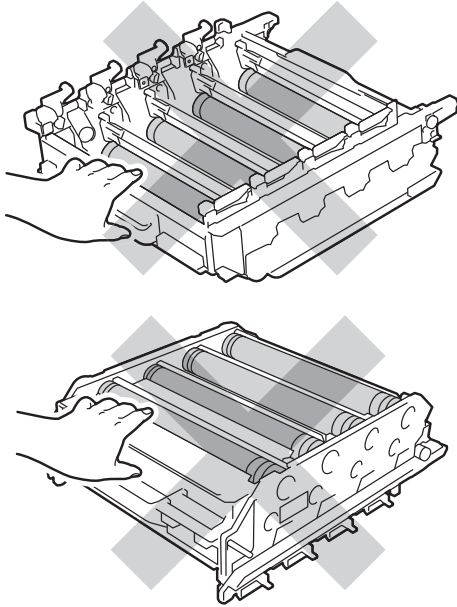

- 7 Turn the drum unit over by holding the green handles. Make sure that the drum unit gears (1) are on the left hand side.

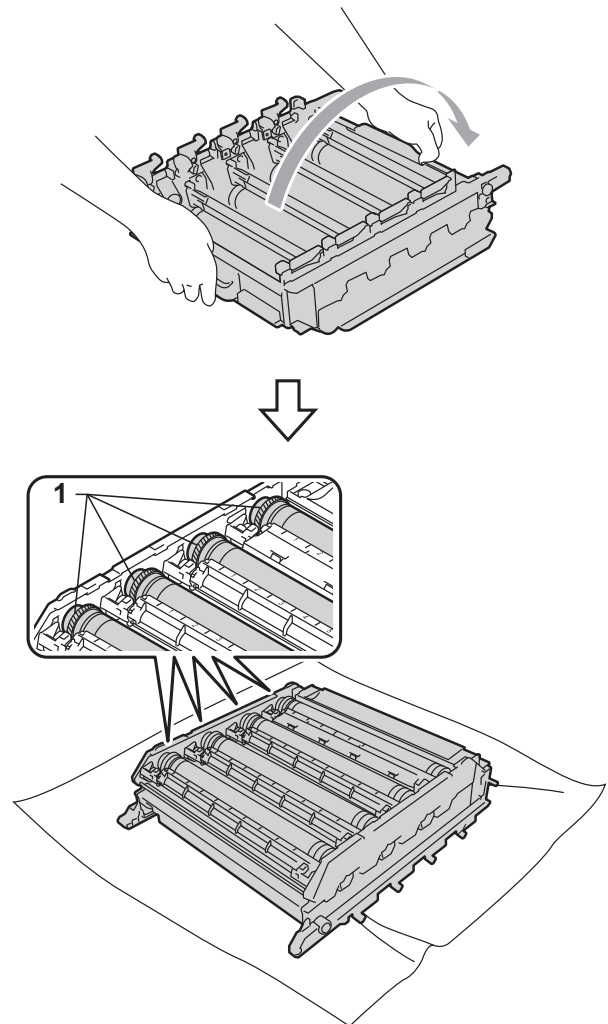

- 8 Note the following information from the drum dot check sheet:

- Dot color

For example, a mark on the cyan drum would produce a cyan dot on the check sheet.

- Dot location

Note which of the printed columns the dot appears in.

- 9 On the problem color drum, use the numbered markers next to the drum roller to find the mark. For example, a cyan dot in column 2 on the check sheet would mean that there is a mark on the cyan drum in the "2" region.

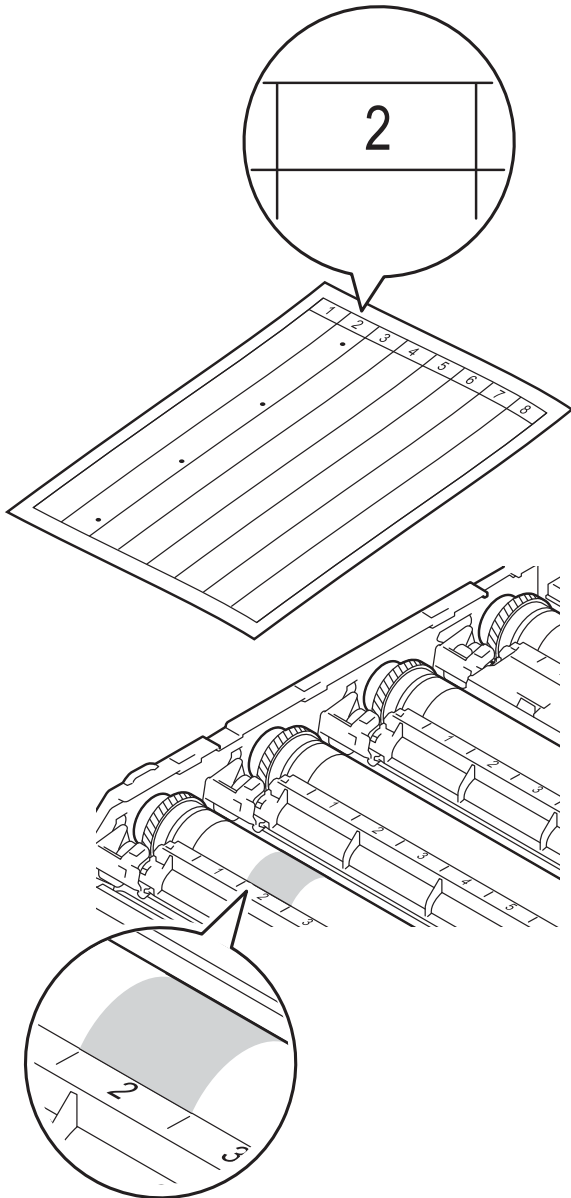

- 10 Turn the drum unit gear toward you by hand while looking at the surface of the suspected area.

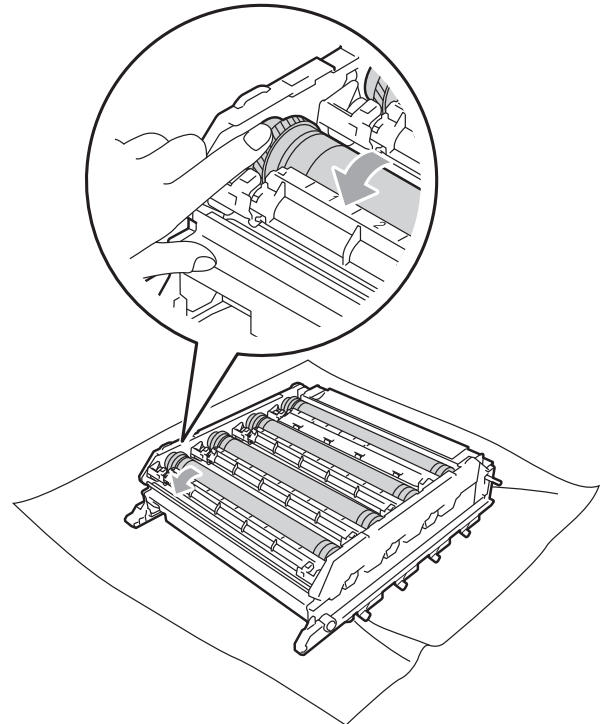

- 11 When you have found the mark on the drum that matches the drum dot check sheet, wipe the surface of the drum gently with a cotton swab until the dust or paper powder on the surface comes off.

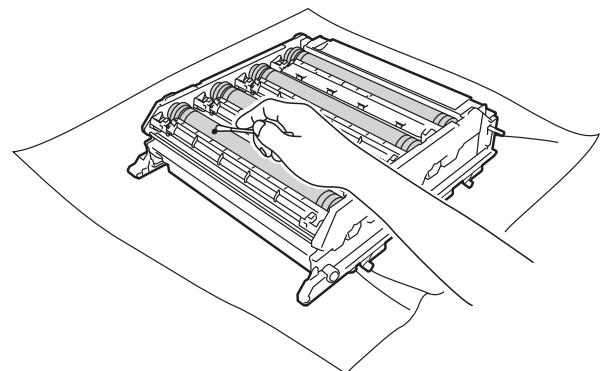

! IMPORTANT

DO NOT clean the surface of the photosensitive drum with a sharp object.

- 12** Hold the handle of the toner cartridge and slide the toner cartridge into the drum unit then slightly pull it toward you until you hear it click into place. Make sure that you match the toner cartridge color to the same color label on the drum unit. Repeat this for all the toner cartridges.

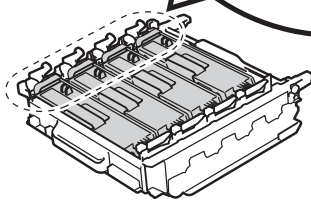
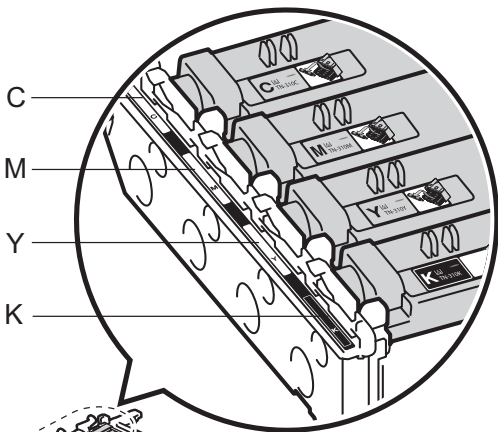
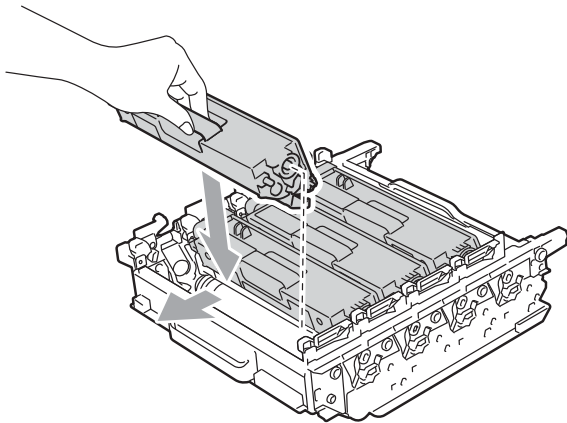

C - Cyan
Y - Yellow

M - Magenta
K - Black

- 13** Make sure the green lock lever (1) is in the release position as shown in the illustration.

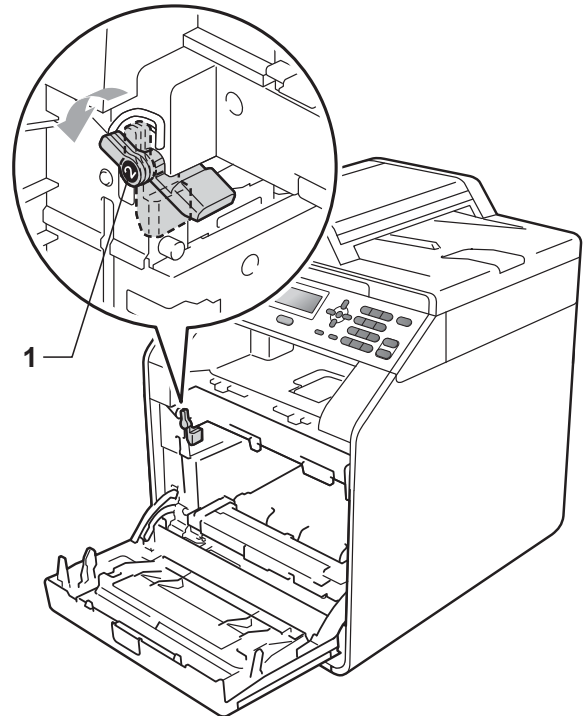

- 14** Match the guide ends (2) of the drum unit to the ► marks (1) on both sides of the machine, then gently slide the drum unit into the machine until it stops at the green lock lever.

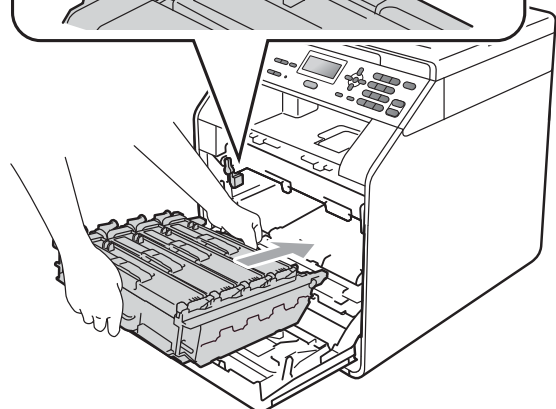
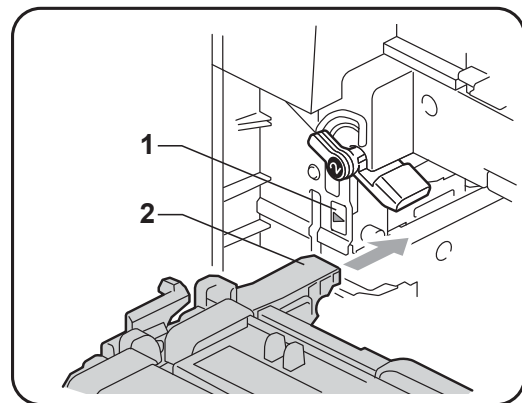

- 15 Turn the green lock lever (1) clockwise to the lock position.

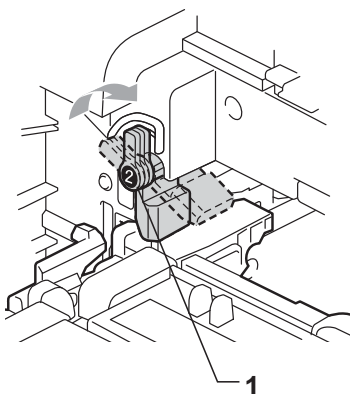

- 16 Push the drum unit in until it stops.

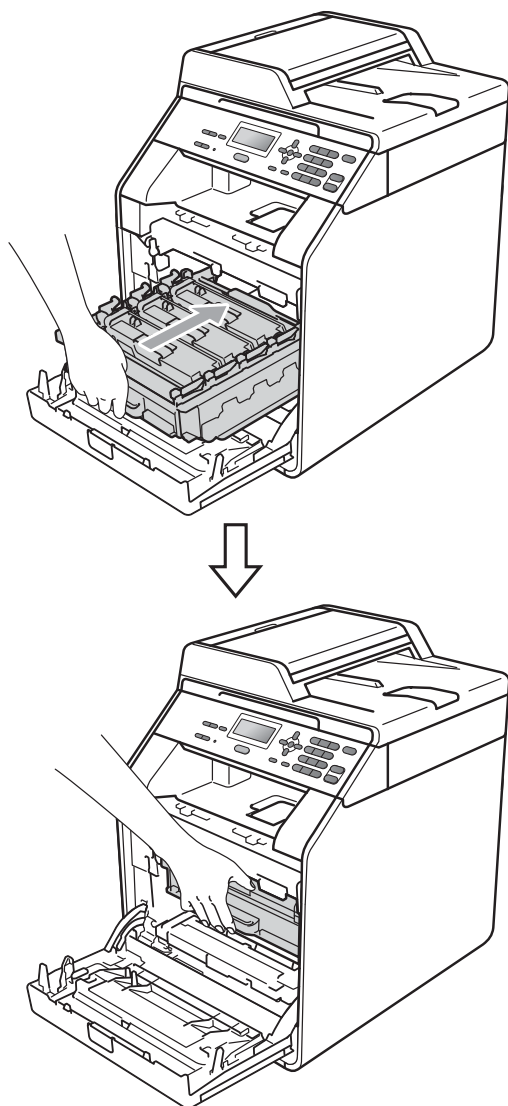

- 17 Close the front cover of the machine.

- 18 Plug the machine's power cord back into the electrical socket first, and connect all cables. Turn on the machine.

Cleaning the paper pick-up rollers

If you have paper feed problems, clean the pick-up rollers as follows:

- 1 Turn off the machine. Unplug the power cord from the electrical socket.
- 2 Pull the paper tray completely out of the machine.

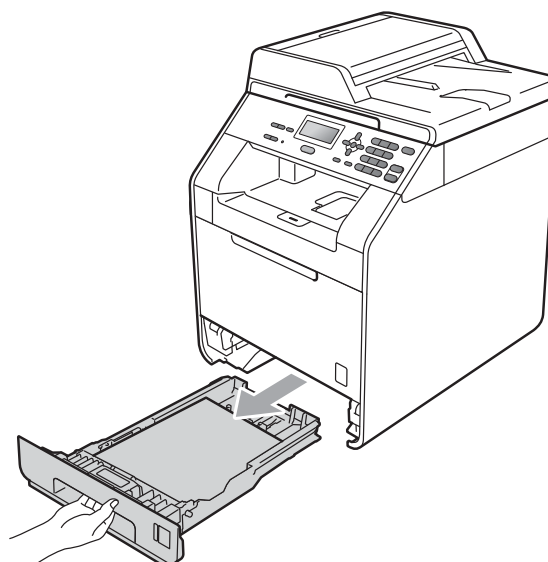

A

- 3 Tightly wring out a lint-free cloth soaked in lukewarm water, and then wipe the separator pad (1) of the paper tray with it to remove dust.

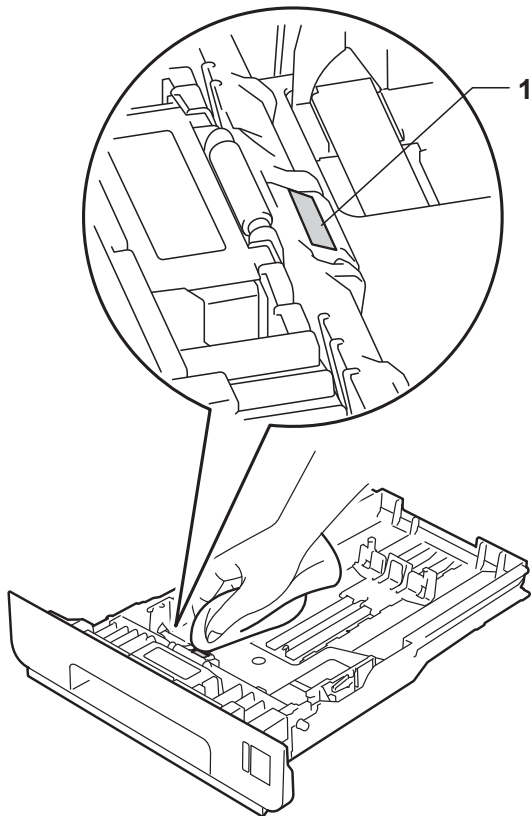

- 4 Wipe the two pick-up rollers (1) inside the machine to remove dust.

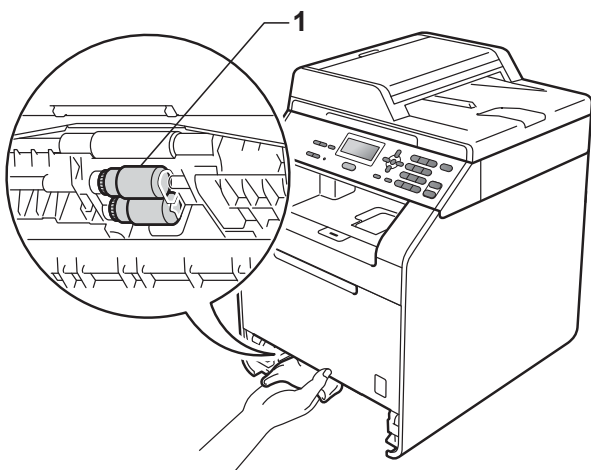

- 5 Put the paper tray back in the machine.
- 6 Plug the machine's power cord back into the electrical socket. Turn on the machine.

Calibration

The output density for each color may vary depending on the environment the machine is in such as temperature and humidity. Calibration helps you to improve the color density.

- 1 Press **Menu**, **3**, **6**.
- 2 Press **▲** or **▼** to select **Calibrate**.
- 3 Press **OK**.
- 4 Press **1** to select **Yes**.
- 5 Press **Stop/Exit**.

You can reset the calibration parameters back to those set at the factory.

- 1 Press **Menu**, **3**, **6**.
- 2 Press **▲** or **▼** to **Reset**.
- 3 Press **OK**.
- 4 Press **1** to select **Yes**.
- 5 Press **Stop/Exit**.



Note

- If an error message is displayed, press **Stop/Exit** and try again. (For more information, see *Error and maintenance messages* on page 78.)
- If you print using the Windows® printer driver, the driver will get the calibration data automatically if both **Use Calibration Data** and **Get device data automatically** are on. The default settings are on. (See *Advanced tab* in the *Software User's Guide*.)

- If you print using the Macintosh printer driver, you need to perform the calibration using the **Status Monitor**. After turning the **Status Monitor** on, choose **Color Calibration** from the **Control** menu. (See *Status Monitor* in the *Software User's Guide*. When the **StatusMonitor** is open, choose **Control / Color Calibration** from the menu bar.)

Auto Registration

Registration

If solid areas of color or images have cyan, magenta or yellow fringes, you can use the auto-registration feature to correct the problem.

- 1 Press **Menu**, **3**, **7**.
- 2 To start, press **1**.
To exit, press **2**.
- 3 Press **Stop/Exit**.

Manual Registration

If color still appears incorrectly after auto-registration, you will need to perform manual registration.

- 1 Press **Menu**, **3**, **8**, **1**.
- 2 Press **Mono Start** or **Color Start** to start printing the color registration chart.
- 3 When the machine has finished printing the registration chart, press **2** (*Set Regist.*) to correct the color manually.
- 4 Starting at **1** (*1 Magenta Left*) on the chart, check which colored bar has the most uniform print density and enter its number into the machine using the **▲** and **▼** keys.
Press **OK**.

Repeat for **2** (*2 Cyan Left*), **3** (*3 Yellow Left*), **4**, **5**, **6** to **9**.

- 5 Press **Stop/Exit**.

Frequency (Color Correction)

You can set how often the color correction (Color Calibration and Auto Registration) occurs. The default setting is Normal. The color correction process consumes some amount of the toner.

- 1 Press **Menu**, **3**, **9**.
- 2 Press **▲** or **▼** to choose *Normal*, *Low* or *Off*.
Press **OK**.
- 3 Press **Stop/Exit**.

B

Troubleshooting

Error and maintenance messages

As with any sophisticated office product, errors may occur and consumable items may need to be replaced. If this happens, your machine identifies the error or required routine maintenance and shows the appropriate message. The most common error and maintenance messages are shown below.

You can clear most errors and perform routine maintenance messages by yourself. If you need more help, the Brother Solutions Center offers the latest FAQs and troubleshooting tips:

Visit us at <http://solutions.brother.com/>.

Error Message	Cause	Action
Access Denied	The function you want to use is restricted by Secure Function Lock.	Contact your administrator to check your Secure Function Lock Settings.
Calibrate	Calibration failed.	<p>Press Mono Start or Color Start and try it again.</p> <ul style="list-style-type: none"> ■ Turn off the machine. Wait a few seconds, then turn it on again. ■ Put in a new drum unit. (See <i>Replacing the drum unit</i> on page 44.) ■ Put in a new belt unit. (See <i>Replacing the belt unit</i> on page 49.) ■ Put in a new waste toner box. (See <i>Replacing the waste toner box</i> on page 54.) ■ If the problem continues, call your Brother dealer.
Cartridge Error ¹ Put the Black (K) Toner Cartridge back in.	The toner cartridge is not installed correctly.	Pull out the drum unit and remove the toner cartridge for the color that is indicated on the LCD, then re-install toner cartridge in the drum unit. Put the drum unit back into the machine again.
¹ The toner cartridge color with the problem is shown in the message.		
Condensation	One of the issues that can cause this error is that condensation may form inside the machine after a room temperature change.	Leave switched ON. Fully open the front cover. Wait 30 minutes, switch OFF and close cover, then switch ON. If this does not clear the error, call your Brother dealer.

Error Message	Cause	Action
Cooling Down Wait for a while	The temperature of the drum unit or toner cartridge is too hot. The machine will pause its current print job and go into cooling down mode. During the cooling down mode, you will hear the cooling fan running while the LCD shows <i>Cooling Down</i> , and <i>Wait for a while</i> .	<p>Make sure that you can hear the fan in the machine spinning and that the exhaust outlet is not blocked by something.</p> <p>If the fan is spinning, remove any obstacles that surround the exhaust outlet, and then leave the machine turned on but do not use it for several minutes.</p> <p>If the fan is not spinning, disconnect the machine from the power for several minutes, then reconnect it.</p>
Cover is Open	The front cover is not completely closed.	Close the front cover of the machine.
Cover is Open	The ADF cover is not completely closed.	Close the ADF cover of the machine.
	The ADF is open while loading a document.	Close the ADF cover of the machine, then press Stop/Exit .
Cover is Open	The fuser cover is not completely closed or paper was jammed in the back of the machine when you turned on the power.	<ul style="list-style-type: none"> ■ Close the fuser cover of the machine. ■ Make sure paper is not jammed inside the back of the machine, and then close the fuser cover and press Mono Start or Color Start.
DIMM Error	<ul style="list-style-type: none"> ■ The DIMM is not installed correctly. ■ The DIMM is broken. ■ The DIMM does not meet the required specifications. 	<ul style="list-style-type: none"> ■ Turn off the machine and remove the DIMM. ■ Confirm the DIMM meets the required specifications. (See <i>Memory board in Appendix B of the Advanced User's Guide</i>.) ■ Re-install the DIMM correctly. Wait a few seconds, and then turn it on again. ■ If this error message appears again, replace the DIMM with a new one. (See <i>Installing extra memory in Appendix B of the Advanced User's Guide</i>.)
Document Jam	The document was not inserted or fed correctly, or the document scanned from the ADF was too long.	See <i>Document is jammed in the top of the ADF unit</i> on page 83 or <i>Using the automatic document feeder (ADF)</i> on page 24.
Drum Error	The corona wire on the drum unit needs to be cleaned.	Clean the corona wire on the drum unit. (See <i>Cleaning the corona wires</i> on page 66.)
Drum Stop	It is time to replace the drum unit.	Replace the drum unit. (See <i>Replacing the drum unit</i> on page 44.)



Error Message	Cause	Action
Duplex Disabled Close the Back Cover of the machine.	The back of the machine is not closed completely.	Close the back cover of the machine.
Duplex Disabled Reload paper, then press Start.	Although the size of paper in the paper tray matches the paper size that was selected from the control panel or printer driver, the machine has stopped printing when it encountered an additional, different size of paper in the tray.	Make sure the paper tray contains only the size of paper you select in either the control panel or printer driver, then press Mono Start or Color Start .
	The paper tray was pulled out before the machine completed printing on both sides of the paper.	Re-install the paper tray and press Mono Start or Color Start .
EL Error	The machine has a mechanical problem.	Open the front cover and close it again.
Fuser Error	The temperature of the fuser unit does not rise to a specified temperature within the specified time.	Turn the power switch off, wait a few seconds, and then turn it on again. Leave the machine for 15 minutes with the power on.
	The fuser unit is too hot.	
Init Unable XX (XX=Error Code)	The machine has a mechanical problem.	<ul style="list-style-type: none"> ■ Turn the power switch off, and then turn it on again. ■ If the problem continues, call your Brother dealer.
Jam Duplex	The paper is jammed underneath Paper Tray 1.	(See <i>Paper is jammed underneath paper tray 1</i> on page 91.)
Jam Inside	The paper is jammed inside the machine.	(See <i>Paper is jammed inside the machine</i> on page 88.)
Jam MP Tray	The paper is jammed in the MP tray of the machine.	(See <i>Paper is jammed in the MP tray</i> on page 84.)
Jam Rear	The paper is jammed in the back of the machine.	(See <i>Paper is jammed at the back of the machine</i> on page 86.)
Jam Tray 1 Jam Tray 2	The paper is jammed in the paper tray of the machine.	(See <i>Paper is jammed in the Paper Tray 1 or Tray 2</i> on page 85.)
Limit Exceeded	The printing limit set by Secure Function Lock 2.0 was reached.	Contact your administrator to check your Secure Function Lock Settings.
Low Temperature	The room temperature is too low for the machine to operate.	Increase the room temperature to allow the machine to operate.
No Belt Unit	The belt unit is not installed correctly.	Re-install the belt unit. (See <i>Replacing the belt unit</i> on page 49.)

Error Message	Cause	Action
No Paper	The machine is out of paper or paper is not correctly loaded in the paper tray.	Do one of the following: <ul style="list-style-type: none"> ■ Refill the paper in the paper tray. ■ Remove the paper and load it again. ■ If the problem is not resolved, the paper pick-up roller may need to be cleaned. Clean the paper pick-up roller. (See <i>Cleaning the paper pick-up rollers</i> on page 75.)
No Permission	You have attempted to print in color using a Secure Function Lock ID that is restricted to mono printing only. The print job will be cancelled.	Contact your administrator to check your Secure Function Lock Settings.
No Toner	The toner cartridge for the color indicated on the LCD is not installed correctly.	Pull out the drum unit. Take out the toner cartridge for the color indicated on the LCD, and then put it back into the drum unit.
No Tray	The paper tray indicated on the LCD is not installed properly.	Re-install the paper tray that is indicated on the LCD.
No Waste Toner	The waste toner box is not installed properly.	Re-install the waste toner box. (See <i>Replacing the waste toner box</i> on page 54.)
Not Available	The attempted function is restricted by Secure Function Lock 2.0.	Contact your administrator to check your Secure Function Lock Settings.
Out of Memory	The machine's memory is full.	Do one of the following: <ul style="list-style-type: none"> ■ Press Mono Start or Color Start to copy the scanned pages. (Copy operation in progress) ■ Press Stop/Exit and wait until the other operations in progress finish, and then try again. ■ Reduce print quality. (See <i>Advanced tab</i> in the <i>Software User's Guide</i>.) ■ Add optional memory. (See <i>Memory board</i> in <i>Appendix B</i> of the <i>Advanced User's Guide</i>.)
Print Unable XX (XX=Error Code)	The machine has a mechanical problem.	Do one of the following: <ul style="list-style-type: none"> ■ Turn the power switch off, wait a few minutes, and then turn it on again. ■ If the problem continues, call your Brother dealer.



Error Message	Cause	Action
Registration	Registration failed.	<p>Press Mono Start or Color Start and try again.</p> <p>Do one of the following:</p> <ul style="list-style-type: none"> ■ Turn off the machine's power switch. Wait a few seconds, then turn it on again. ■ Try Manual Registration, Menu, 3, 8. (See <i>Manual Registration</i> on page 77.) ■ Put in a new belt unit. (See <i>Replacing the belt unit</i> on page 49.) ■ If the problem continues, call your Brother dealer.
Replace Parts Belt Unit	It is time to replace the belt unit.	Replace the belt unit. (See <i>Replacing the belt unit</i> on page 49.)
Replace Parts Drum	It is time to replace the drum unit.	Replace the drum unit. (See <i>Replacing the drum unit</i> on page 44.)
	The drum unit counter was not reset when a new drum was installed.	Reset the drum unit counter. (See <i>Resetting the drum counter</i> on page 49.)
Replace Parts Fuser Unit	It is time to replace the fuser unit.	Call your Brother dealer or a Brother Authorized Service Center to replace the fuser unit.
Replace Parts PF Kit 1 PF Kit 2 PF Kit MP	It is time to replace the paper feeding kit.	Call your Brother dealer or a Brother Authorized Service Center to replace the PF Kit.
Replace Toner	The toner cartridge is at the end of its life.	Replace the toner cartridge for the color indicated on the LCD. (See <i>Replacing a Toner cartridge</i> on page 37.)
Replace WT Box	It is time to replace the waste toner box.	Replace the waste toner box. (See <i>Replacing the waste toner box</i> on page 54.)
Scan Unable XX (XX=Error Code)	The machine has a mechanical problem.	<ul style="list-style-type: none"> ■ Turn the power switch off and then turn it on again. ■ If the problem continues, call your Brother dealer.
Short paper	The length of the paper in the tray is too short for the machine to deliver it to the Face-down output tray.	Open the back cover to let the printed paper out on the back output tray. Remove the printed pages and then press Mono Start or Color Start .
Size Error DX	The paper size defined in the printer driver is not usable for the automatic duplex printing.	Press Mono Start or Color Start . Choose a paper size which is supported by the duplex tray. (See <i>Type and size of paper</i> on page 19.)

Error Message	Cause	Action
Size mismatch	The paper in the tray is not the correct size.	Load the correct size of paper in the tray and set the "Paper Size" (Menu, 1, 1, 2). (See <i>Paper Size</i> on page 18.)
Small paper	The paper size specified in the printer driver is too small for the machine to deliver it to the Face-down output tray.	Open the back cover to let the printed paper out on the back output tray and then press Mono Start or Color Start .
Toner Error	One or more toner cartridges are not installed correctly.	Pull out the drum unit. Take out all the toner cartridges, and then put them back into the drum unit.
Toner Low	The toner cartridge is near the end of its life.	Buy a new toner cartridge for the color that is indicated on the LCD before you get a Replace Toner message.
WT Box End Soon	The waste toner box is near the end of its life.	Buy a new waste toner box before you get a Replace WT Box message.

Document is jammed in the top of the ADF unit

- 1 Take out any paper from the ADF that is not jammed.
- 2 Open the ADF cover.
- 3 Pull the jammed document out to the left.

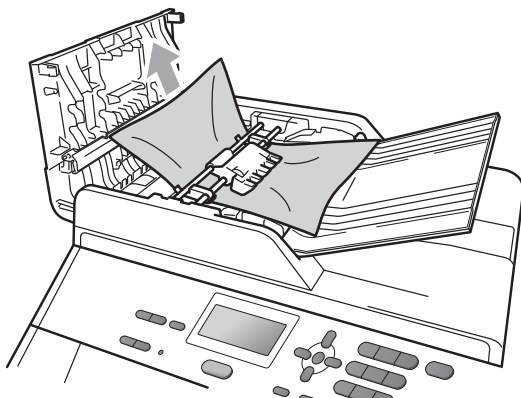

- 4 Close the ADF cover.
- 5 Press **Stop/Exit**.

Document is jammed under the document cover

- 1 Take out any paper from the ADF that is not jammed.
- 2 Lift the document cover.
- 3 Pull the jammed document out to the right.

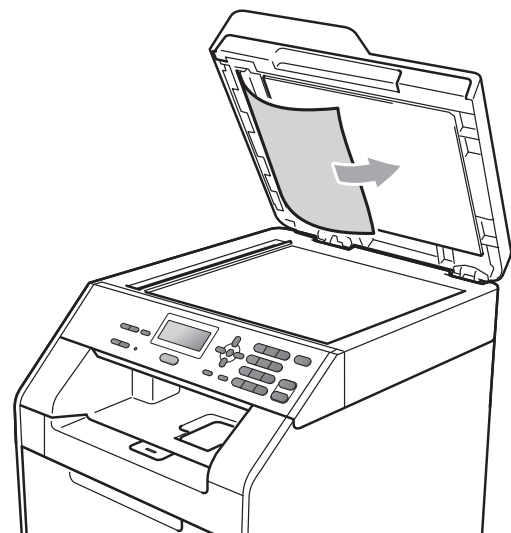

- 4 Close the document cover.
- 5 Press **Stop/Exit**.

Removing small documents jammed in the ADF

- 1 Lift the document cover.
- 2 Insert a piece of stiff paper, such as cardstock, into the ADF to push any small paper scraps through.

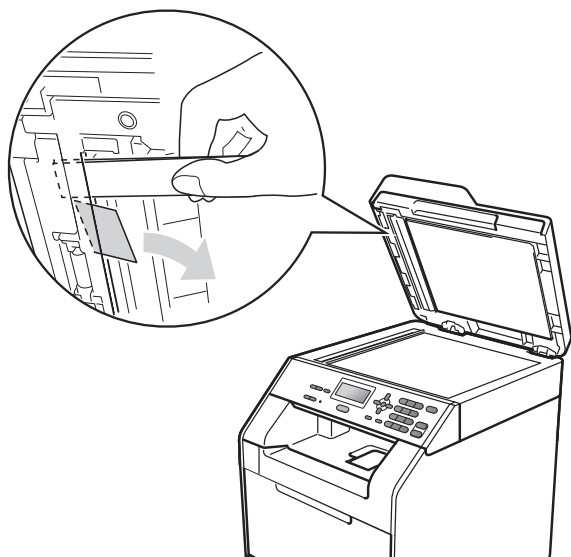

- 3 Close the document cover.
- 4 Press **Stop/Exit**.

Document is jammed at the output tray

- 1 Take out any paper from the ADF that is not jammed.
- 2 Pull the jammed document out to the right.

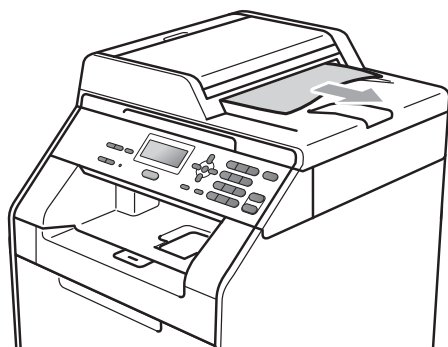

- 3 Press **Stop/Exit**.

Paper is jammed in the MP tray

If the LCD shows **Jam MP Tray**, follow these steps:

- 1 Remove the paper from the MP tray.
- 2 Remove any jammed paper from in and around the MP tray.

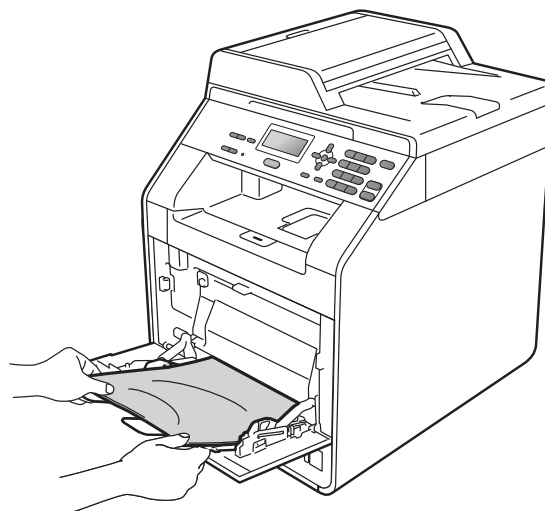

- 3 Fan the paper stack, and then put it back in the MP tray.

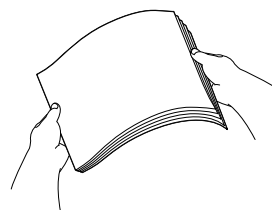

- 4 When loading paper in the MP tray, make sure that the paper stays under the maximum paper height guides (1) on both sides of the tray.

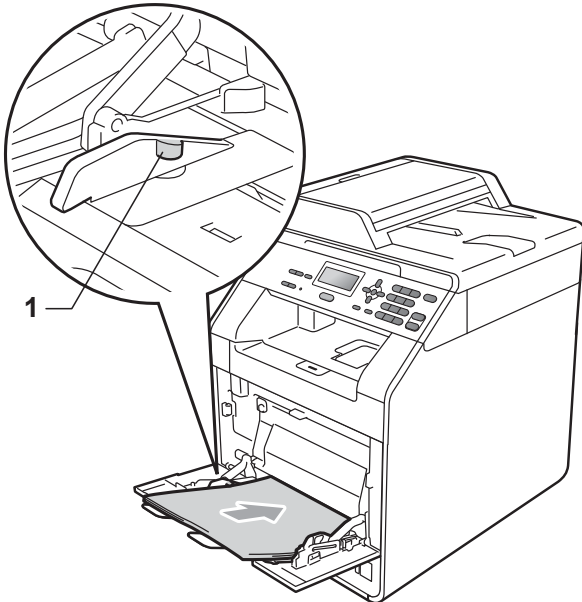

- 5 Press **Mono Start** or **Color Start** to resume printing.

Paper is jammed in the Paper Tray 1 or Tray 2

If the LCD shows Jam Tray 1 or Jam Tray 2, follow these steps:

- 1 Pull the paper tray completely out of the machine.
For Jam Tray 1:

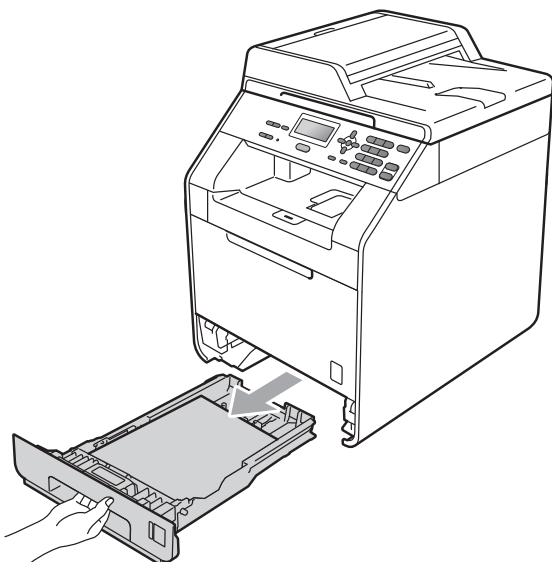

For Jam Tray 2:

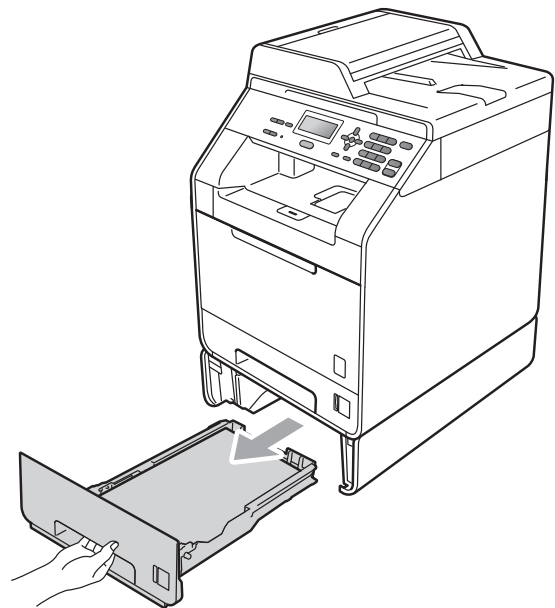

! WARNING

DO NOT touch the shaded parts shown in the illustration. These rollers may be rotating at high speed.

B

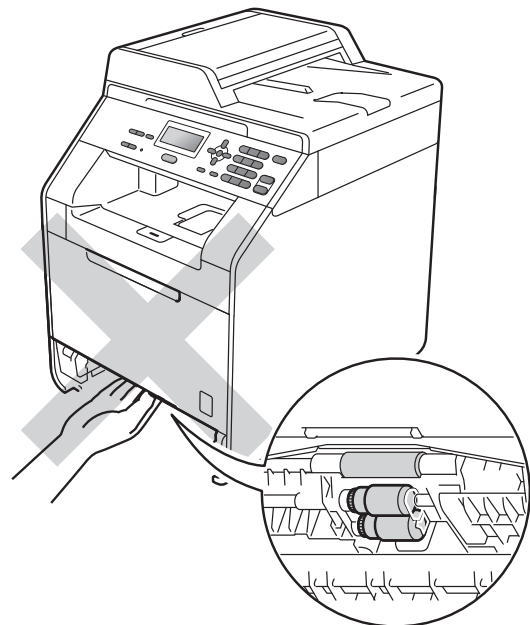

- 2 Use both hands to slowly pull out the jammed paper.

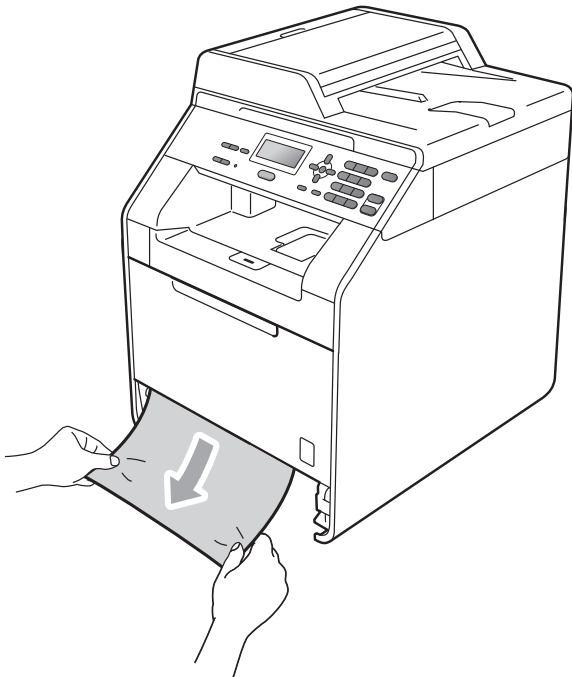

! IMPORTANT

If the paper cannot easily be removed in this direction, stop and follow the instructions for *Paper is jammed inside the machine* on page 88.



Note

Pulling out the jammed paper downwards allows you to remove the paper easier.

- 3 Make sure the paper is below the maximum paper mark (▼▼▼) of the paper tray. While pressing the green paper-guide release lever, slide the paper guides to fit the paper size. Make sure that the guides are firmly in the slots. (See *Loading paper in the standard paper tray* on page 10.)
- 4 Put the paper tray firmly back in the machine.

Paper is jammed at the back of the machine

If the LCD shows *Jam Rear*, a paper jam occurred behind the back cover. Follow these steps:

- 1 Leave the machine turned on for 10 minutes to cool down.
- 2 Open the back cover.

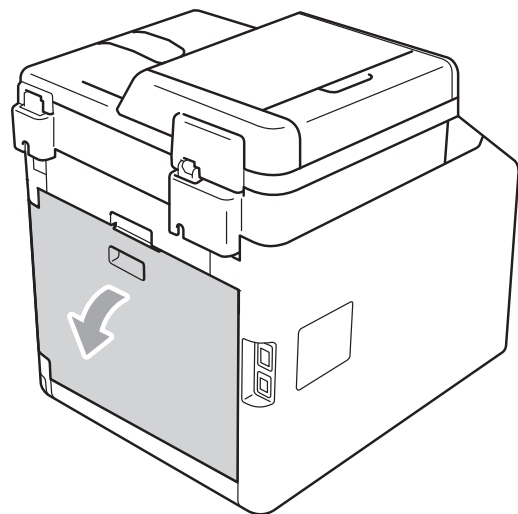

! CAUTION

! HOT SURFACE

After you have just used the machine, some internal parts of the machine will be extremely hot. Wait for the machine to cool down before you touch the internal parts of the machine.

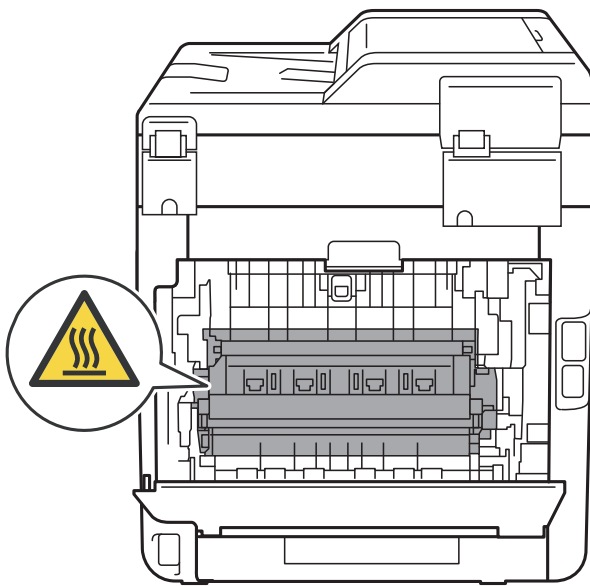

- 3** Pull the green tabs (2) at the left and right hand sides toward you and fold down the fuser cover (1).

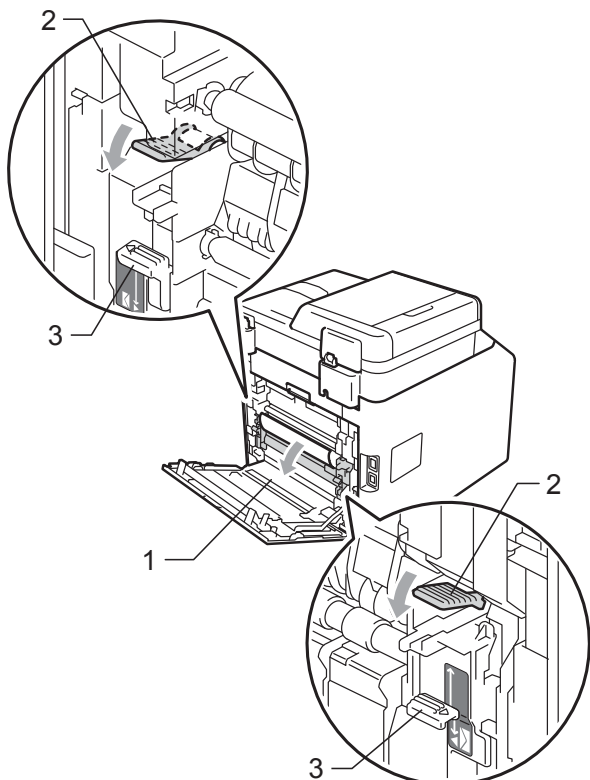

Note

If the envelope levers (3) inside the back cover are pulled down to the envelope position, lift these levers to the original position before pulling the green tabs (2) down.

- 4** Using both hands, gently pull the jammed paper out of the fuser unit.

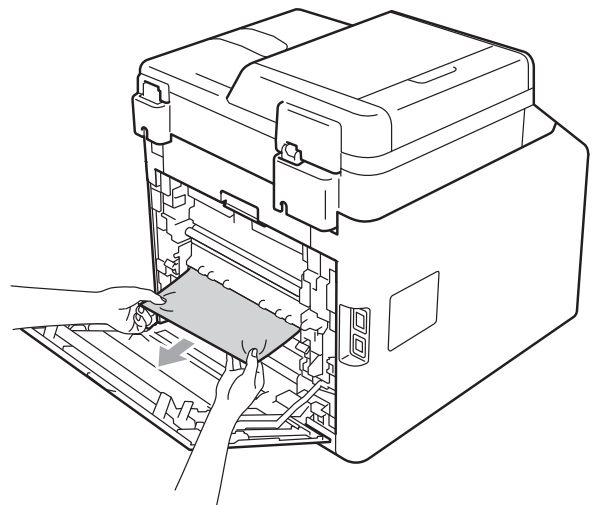

- 5** Close the fuser cover (1).

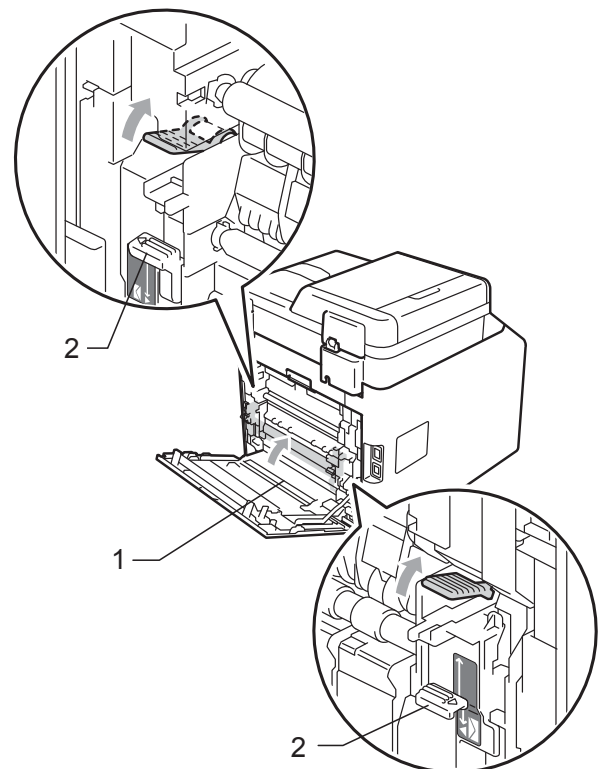

 **Note**

If you print on envelopes, pull down the envelope levers (2) to the envelope position again before closing the back cover.

- 6 Fully close the back cover.

Paper is jammed inside the machine

If the LCD shows *Jam Inside*, follow these steps:

- 1 Turn off the machine. Disconnect all cables, and then unplug the power cord from the electrical socket.

- 2 Press the front cover release button and then open the front cover.

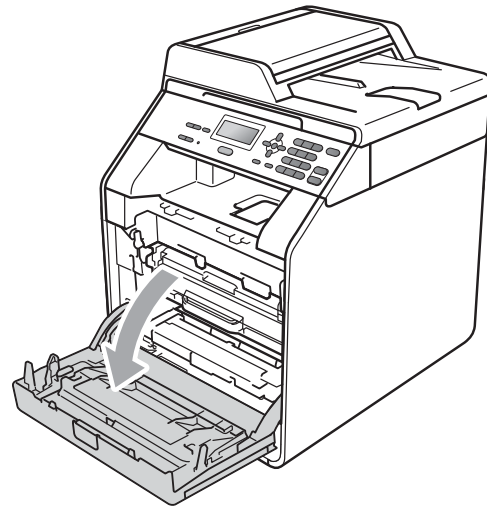
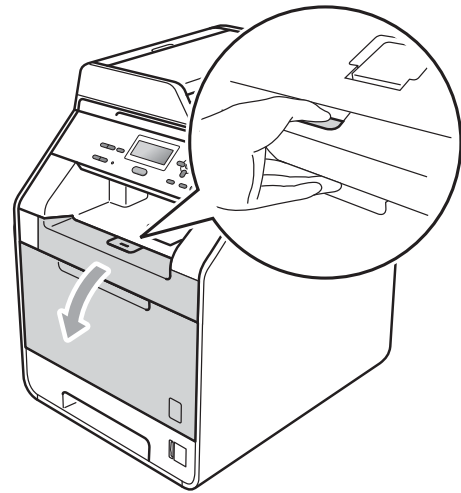

- 3 Hold the green handle of the drum unit. Pull the drum unit out until it stops.

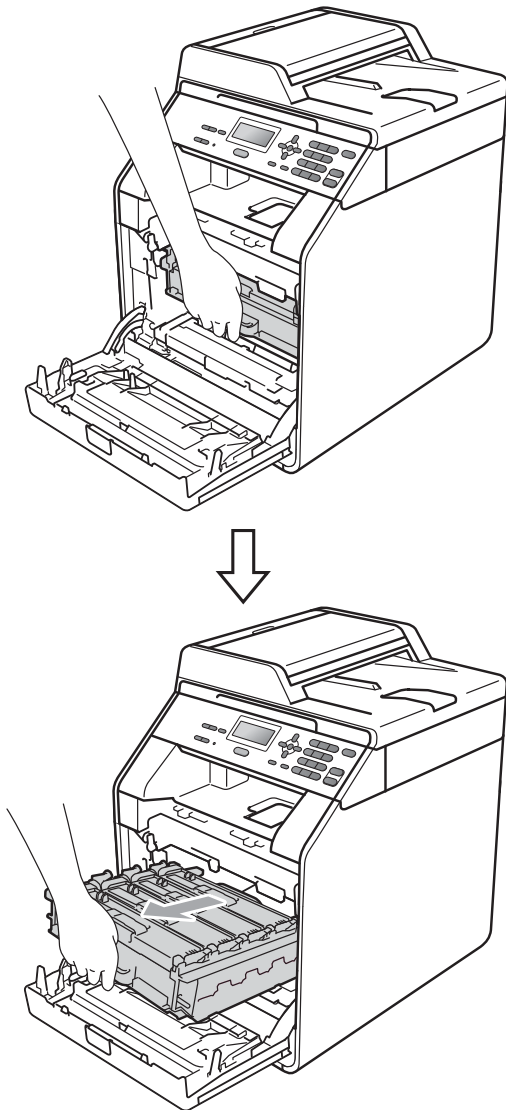

- 4 Turn the green lock lever (1) at the left of the machine anticlockwise to the release position. Holding the green handles of the drum unit, lift the front of the drum unit and remove it from the machine.

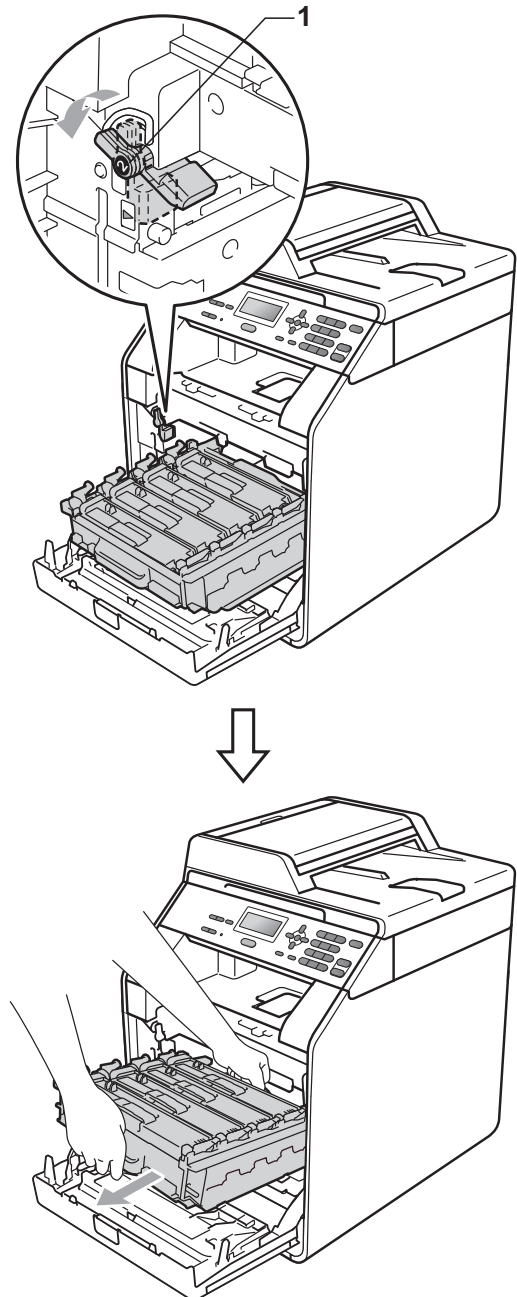

B

! IMPORTANT

- We recommend that you place the drum unit and the toner cartridges on a clean, flat surface with a sheet of disposable paper or cloth underneath it in case you accidentally spill or scatter toner.

- To prevent damage to the machine from static electricity, **DO NOT** touch the electrodes shown in the illustration.

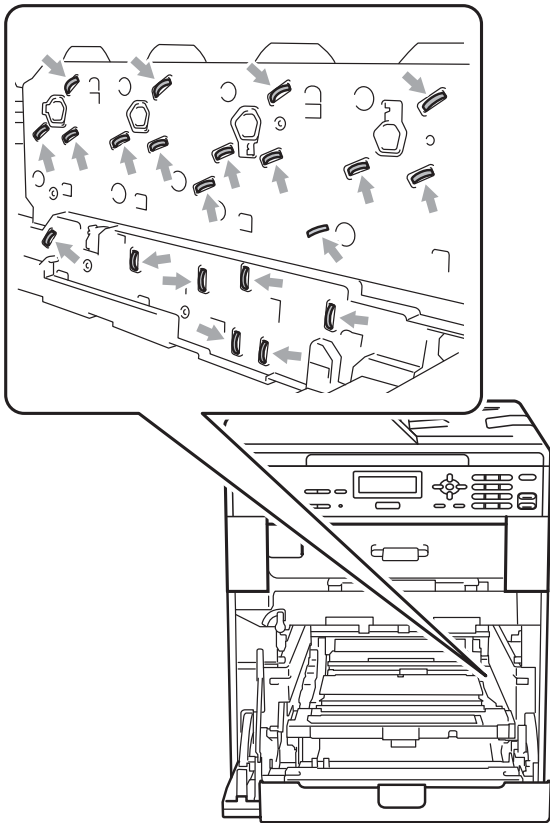

- Hold the green handles of the drum unit when you carry it. **DO NOT** hold the side of the drum unit.

5 Pull out the jammed paper slowly.

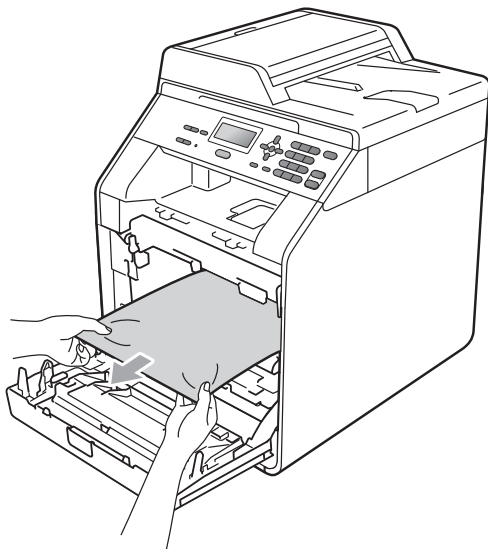

6 Make sure the green lock lever (1) is in the release position as shown in the illustration.

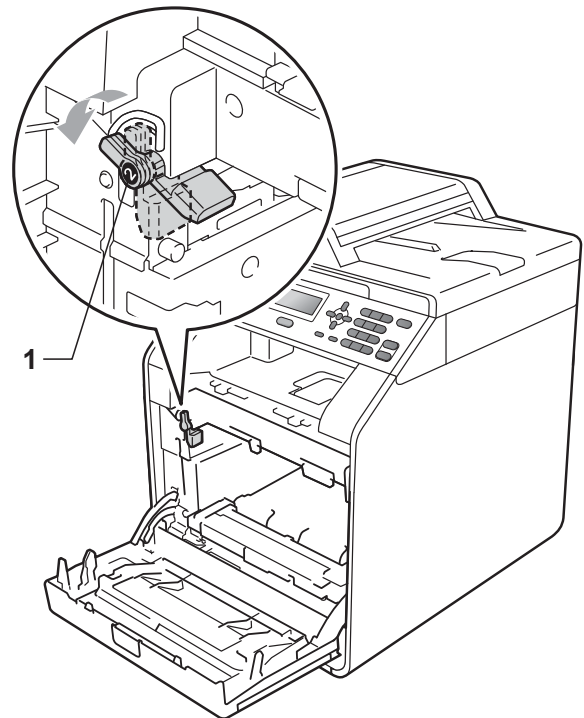

7 Match the guide ends (2) of the drum unit to the ► marks (1) on both sides of the machine, then gently slide the drum unit into the machine until it stops at the green lock lever.

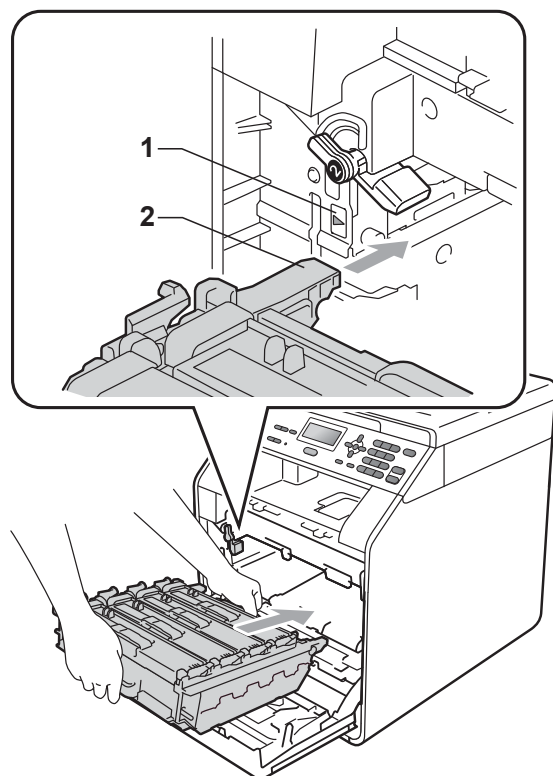

- 8 Turn the green lock lever (1) clockwise to the lock position.

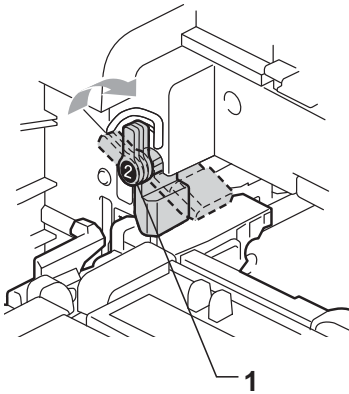

- 9 Push the drum unit in until it stops.

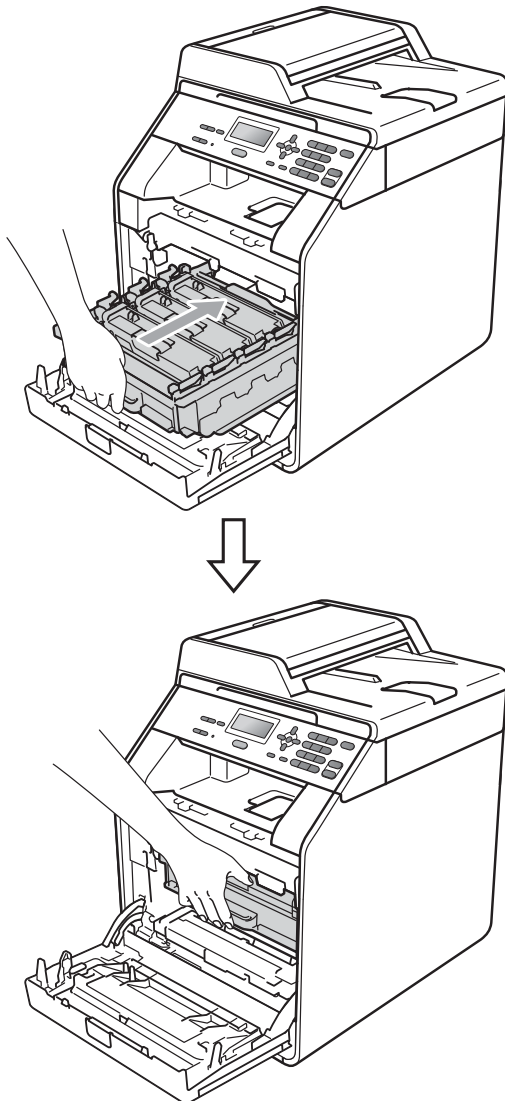

- 10 Close the front cover of the machine.



Note

If you turn off the machine during *Jam Inside*, the machine will print incomplete data from your computer. Before you turn on the machine, delete the print spool job on your computer.

- 11 Plug the machine's power cord back into the electrical socket first, and reconnect all cables. Turn on the machine.

Paper is jammed underneath paper tray 1

If the LCD shows *Jam Duplex*, follow these steps:

- 1 Pull the paper tray completely out of the machine.

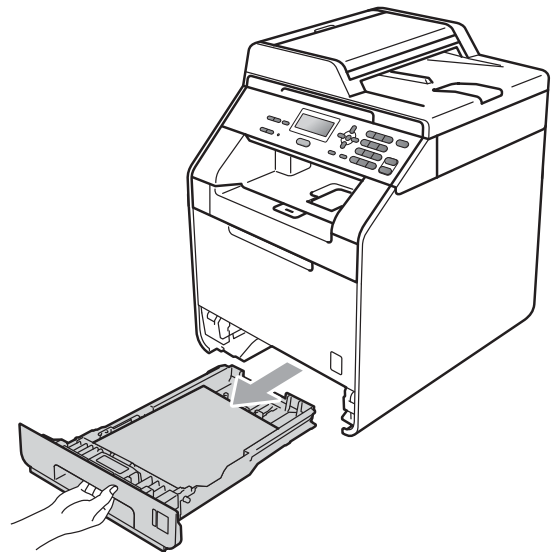

! WARNING

DO NOT touch the shaded parts shown in the illustration. These rollers may be rotating at high speed.

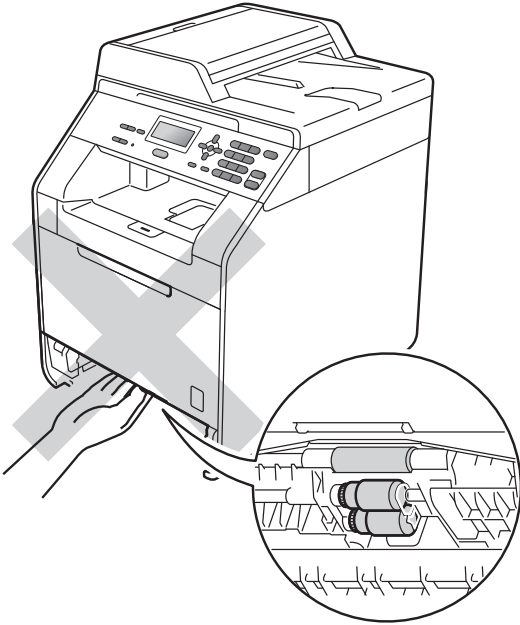

- 2** If paper is not caught inside the machine, check underneath the paper tray.

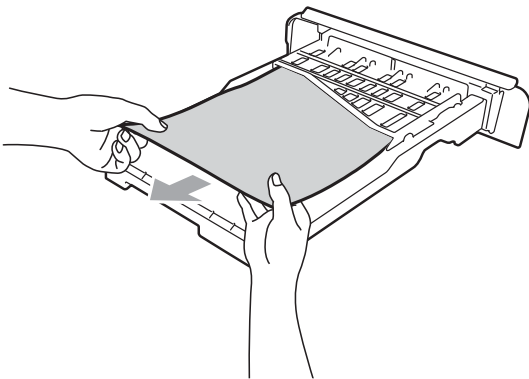

- 3** Put the paper tray firmly back in the machine.

Troubleshooting

If you think there is a problem with your machine, check the chart below and follow the troubleshooting tips.

Most problems can be easily resolved by yourself. If you need additional help, the Brother Solutions Center offers the latest FAQs and troubleshooting tips.

Visit us at <http://solutions.brother.com/>.

If you are having difficulty with your machine

Check the chart below and follow the troubleshooting tips.

Copy difficulties

Difficulties	Suggestions
Can not make a copy	Contact your administrator to check your Secure Function Lock settings.
Vertical black line appears in copies.	Black vertical lines on copies are typically caused by dirt or correction fluid on the glass strip, or one or more corona wires are dirty. (See <i>Cleaning the scanner glass</i> on page 61 and <i>Cleaning the corona wires</i> on page 66.)
Copies are blank.	Make sure you are loading the document properly. (See <i>Using the automatic document feeder (ADF)</i> on page 24 or <i>Using the scanner glass</i> on page 25.)

Printing difficulties

Difficulties	Suggestions
No printout.	<ul style="list-style-type: none"> ■ Check that the machine is plugged in and the power switch is turned on. ■ Check that the toner cartridge and drum unit are installed correctly. (See <i>Replacing the drum unit</i> on page 44.) ■ Check the interface cable connection on both the machine and your computer. (See the <i>Quick Setup Guide</i>.) ■ Check that the correct printer driver has been installed and chosen. ■ Check to see if the LCD is showing an error message. (See <i>Error and maintenance messages</i> on page 78.) ■ Check the machine is online: (Windows® 7 and Windows Server® 2008 R2) Click the Start button and Devices and Printers. Right-click Brother DCP-XXXX Printer. Make sure that Use Printer Offline is unchecked. (Windows Vista®) Click the Start button, Control Panel, Hardware and Sound, and then Printers. Right-click Brother DCP-XXXX Printer. Make sure that Use Printer Offline is unchecked. (Windows® XP and Windows Server® 2003/2008) Click the Start button and choose Printers and Faxes. Right-click Brother DCP-XXXX Printer. Make sure that Use Printer Offline is unchecked. (Windows® 2000) Click the Start button and choose Settings and then Printers. Right-click Brother DCP-XXXX Printer. Make sure that Use Printer Offline is unchecked. ■ Contact your administrator to check your Secure Function Lock settings.



Printing difficulties (continued)

Difficulties	Suggestions
The machine prints unexpectedly or it prints garbage.	<ul style="list-style-type: none"> ■ Pull out the paper tray and wait until the machine stops printing. Then turn off the machine and disconnect from the power for several minutes. ■ Check the settings in your application to make sure it is set up to work with your machine.
The machine prints the first couple of pages correctly, then some pages have text missing.	<ul style="list-style-type: none"> ■ Check the settings in your application to make sure that it is set up to work with your machine. ■ Your computer is not recognising the machine's input buffer's full signal. Make sure that you connected the interface cable correctly. (See the <i>Quick Setup Guide</i>.)
The headers or footers appear when the document displays on the screen but they do not show up when it is printed.	There is an unprintable area on the top and bottom of the page. Adjust the top and bottom margins in your document to allow for this. (See <i>Scannable area</i> on page 16.)
The machine does not print on both sides of the paper even though the printer driver setting is Duplex.	Check the paper size setting in the printer driver. You need to choose A4 [60 to 105 g/m ²].
The machine is not printing or has stopped printing.	<p>Press Job Cancel.</p> <p>As the machine cancels the job and clears it from the memory it may produce an incomplete printout.</p>

Scanning difficulties

Difficulties	Suggestions
TWAIN errors appear while scanning.	Make sure that the Brother TWAIN driver is chosen as the primary source. In Presto! PageManager, click File, Select source and choose the Brother TWAIN driver.
OCR does not work.	<p>Try increasing the scanning resolution.</p> <p>(Macintosh users) Presto! PageManager must be downloaded and installed before use. See <i>Accessing Brother Support (Macintosh)</i> on page 4 for further instructions.</p>
Network scanning does not work.	See <i>Network difficulties</i> on page 96.
Cannot scan.	Contact your administrator to check your Secure Function Lock Settings.

Software difficulties

Difficulties	Suggestions
Cannot install software or print.	Run the Repair MFL-Pro Suite program on the CD-ROM. This program will repair and reinstall the software.
Cannot perform '2 in 1' or '4 in 1' printing.	Check that the paper size setting in the application and in the printer driver are the same.
The machine does not print from Adobe® Illustrator®.	Try to reduce the print resolution. (See <i>Advanced tab</i> in the <i>Software User's Guide</i> .)

Paper handling difficulties

Difficulties	Suggestions
The machine does not feed paper. The LCD shows <i>No Paper</i> or a Paper Jam message.	<ul style="list-style-type: none"> ■ If there is no paper, load a new stack of paper into the paper tray. ■ If there is paper in the paper tray, make sure it is straight. If the paper is curled, you should straighten it. Sometimes it is helpful to remove the paper, turn the stack over and put it back into the paper tray. ■ Reduce the amount of paper in the paper tray, and then try again. ■ Make sure that manual feed mode is not chosen in the printer driver. ■ Clean the paper pick-up roller. See <i>Cleaning the paper pick-up rollers</i> on page 75. ■ If the LCD shows the Paper Jam message and you still have a problem, see <i>Error and maintenance messages</i> on page 78.
The machine does not feed paper from the MP tray.	<ul style="list-style-type: none"> ■ Make sure that MP tray is chosen in the printer driver. ■ Fan the paper well and put it back in the tray firmly.
How do I print on envelopes?	You can load envelopes in the MP tray. Your application must be set up to print the envelope size you are using. This is usually done in the Page Setup or Document Setup menu of your application. (See your application's manual for more information.)
What paper can I use?	You can use thin paper, plain paper, thick paper, bond paper, recycled paper, glossy paper, envelopes and labels that are made for laser machines. (For details, see <i>Acceptable paper and other print media</i> on page 19.)
There is a paper jam.	Clear the jammed paper. (See <i>Error and maintenance messages</i> on page 78.)

Print quality difficulties

Difficulties	Suggestions
Printed pages are curled.	<ul style="list-style-type: none"> ■ Low quality thin or thick paper or not printing on the recommended side of the paper could cause this problem. Try turning over the stack of paper in the paper tray. ■ Make sure that you choose the Paper Type that suits the print media type you are using. (See <i>Acceptable paper and other print media</i> on page 19.)
Printed pages are smeared.	The Paper Type setting may be incorrect for the type of print media you are using, or the print media may be too thick or have a rough surface. (See <i>Acceptable paper and other print media</i> on page 19 and <i>Basic tab</i> in the <i>Software User's Guide</i> .)
Printouts are too light.	<ul style="list-style-type: none"> ■ If this problem occurs when making copies, set Toner Save mode to OFF in the machine menu settings. (See <i>Toner Save</i> in <i>Chapter 1</i> of the <i>Advanced User's Guide</i>) ■ Set Toner Save mode to OFF in the Advanced tab in the printer driver. (See <i>Advanced tab</i> in the <i>Software User's Guide</i>.) ■ In the Basic tab of the printer driver, click the Settings button and check the Enhance Black Printing check box.



Network difficulties

Difficulties	Suggestions
Cannot print over a wired Network.	<p>If you are having Network problems see the <i>Network User's Guide</i> for more information.</p> <p>Make sure your machine is powered on and is on-line and in the Ready mode. Print the Network Configuration list to see your current Network settings. (See <i>Network Configuration List</i> in <i>Chapter 1</i> of the <i>Advanced User's Guide</i>.) Reconnect the LAN cable to the hub to verify that the cable and network connections are good. If possible, try connecting the machine to a different port on your hub using a different cable. You can check the current wired network status from the Network control panel menu.</p>
The network scanning feature does not work.	<p>(Windows®) It is necessary to set the third-party Security/Firewall Software to allow Network scanning. To add port 54925 for Network scanning, enter the information below:</p> <ul style="list-style-type: none"> ■ In Name: Enter any description, for example Brother NetScan. ■ In Port number: Enter 54925. ■ In Protocol: UDP is selected. <p>Please refer to the instruction manual that came with your third-party Security/Firewall Software or contact the software manufacturer.</p> <p>For more details, you can read FAQs and troubleshooting suggestions at http://solutions.brother.com/.</p> <p>(Macintosh) Re-select your machine in the Device Selector application located in Macintosh HD/Library/Printers/Brother/Utilities/DeviceSelector or from the model list in ControlCenter2.</p>
Your computer cannot find your machine.	<p>(Windows®) The firewall setting on your PC may be rejecting the necessary network connection. (For details, see the instructions above.)</p> <p>(Macintosh) Re-select your machine in the Device Selector application located in Macintosh HD/Library/Printers/Brother/Utilities/DeviceSelector or from the Model pop-up menu of ControlCenter2.</p>

Other

Difficulties	Suggestions
The machine will not turn on.	<p>Adverse conditions on the power connection (such as lightning or a power surge) may have triggered the machine's internal safety mechanisms. Turn the machine off and unplug the power cord. Wait for ten minutes, then plug in the power cord and turn the machine on.</p> <p>If the problem is not solved, turn off the machine. Plug the power cord into a different known working outlet and turn on the machine.</p>

Improving the print quality

If you have a print quality problem, print a test page first (**Menu, 3, 2, 3**). If the printout looks good, the problem is probably not the machine. Check the interface cable connections or try printing a different document. If the printout or test page printed from the machine has a quality problem, check the following steps first. And then, if you still have a print quality problem, check the chart below and follow the recommendations.



 **Note**

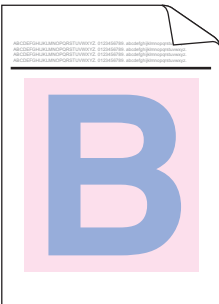

Brother does not recommend the use of cartridges other than Brother Original cartridges or the refilling of used cartridges with toner from other sources.

- 1 To get the best print quality, we suggest using the recommended paper. Check that you use paper that meets our specifications. (See *Acceptable paper and other print media* on page 19.)
- 2 Check that the drum unit and toner cartridges are installed properly.

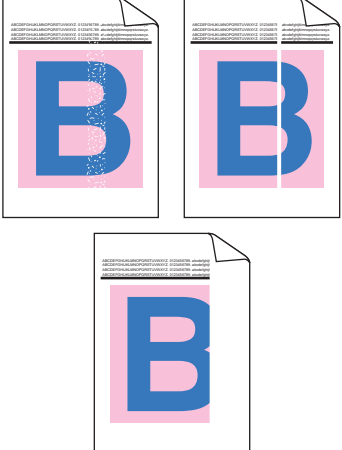
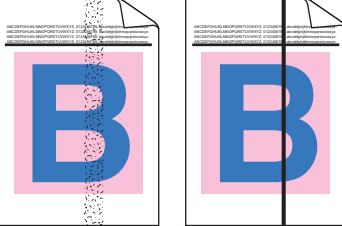
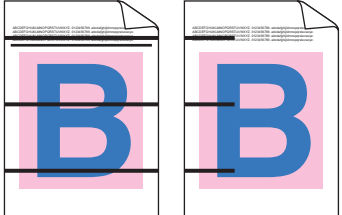

Examples of poor print quality	Recommendation
<p>White lines, bands or ribbing across the page</p> 	<ul style="list-style-type: none"> ■ Put in a new drum unit. (See <i>Replacing the drum unit</i> on page 44.)
<p>Colors are light or unclear on the whole page</p> 	<ul style="list-style-type: none"> ■ Make sure Toner Save mode is off in the control panel of the machine or the printer driver. ■ Make sure that you choose the correct media type in the printer driver or in the machine's Paper Type menu setting. (See <i>Acceptable paper and other print media</i> on page 19 and <i>Basic tab</i> in the <i>Software User's Guide</i>.) ■ Shake all four toner cartridges gently. ■ Wipe the laser scanner windows with a dry lint-free soft cloth. (See <i>Cleaning the laser scanner windows</i> on page 62.) ■ Perform the calibration. (See <i>Calibration</i> on page 76.)

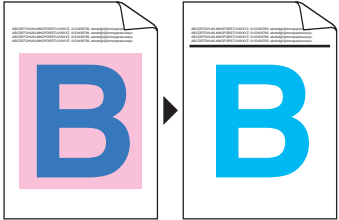
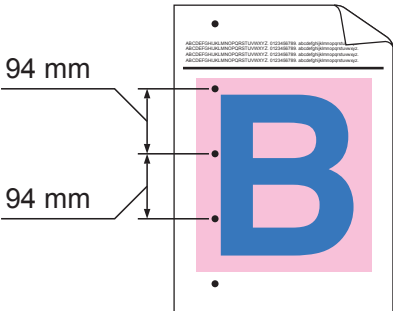
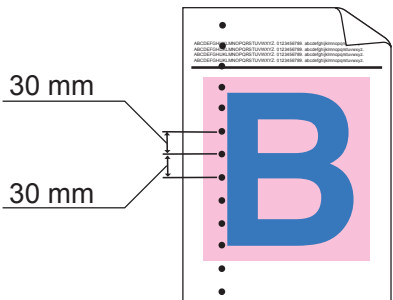
B

Examples of poor print quality	Recommendation
<p>White streaks or bands down the page</p> 	<ul style="list-style-type: none"> ■ Wipe the laser scanner windows with a dry lint-free soft cloth. (See <i>Cleaning the laser scanner windows</i> on page 62.) ■ Clean the drum unit. (See <i>Cleaning the drum unit</i> on page 69.) ■ Identify the missing color and put in a new toner cartridge. (See <i>Replacing a Toner cartridge</i> on page 37.) To identify the color of the toner cartridge, visit us at http://solutions.brother.com/ to view our FAQs and troubleshooting tips.
<p>Colored streaks or bands down the page</p> 	<ul style="list-style-type: none"> ■ Clean all four corona wires (one for each color) inside the drum unit by sliding the green tab. (See <i>Cleaning the corona wires</i> on page 66.) ■ Make sure the corona wire green tabs are at their home positions (▲). ■ Clean the scanner glass and scanner glass strip. (See <i>Cleaning the scanner glass</i> on page 61.) ■ Replace the toner cartridge that matches the color of the streak or band. (See <i>Replacing a Toner cartridge</i> on page 37.) To identify the color of the toner cartridge, visit us at http://solutions.brother.com/ to view our FAQs and troubleshooting tips. ■ Put in a new drum unit. (See <i>Replacing the drum unit</i> on page 44.)
<p>Colored lines across the page</p> 	<ul style="list-style-type: none"> ■ If colored lines appear at 30 mm intervals, replace the toner cartridge that matches the color of the line. (See <i>Replacing a Toner cartridge</i> on page 37.) To identify the color of the toner cartridge, visit us at http://solutions.brother.com/ to view our FAQs and troubleshooting tips. ■ If colored lines appear at 94 mm intervals, put in a new drum unit. (See <i>Replacing the drum unit</i> on page 44.)
<p>White spots or hollow print</p> 	<ul style="list-style-type: none"> ■ Make sure that the media type settings in the printer driver and in the machine's Paper Type menu matches the type of paper you are using. (See <i>Acceptable paper and other print media</i> on page 19 and <i>Basic tab</i> in the <i>Software User's Guide</i>.) ■ Check the machine's environment. Conditions such as high humidity can cause white spots or hollow print. (See <i>To use the product safety</i> in the <i>Safety and Legal Booklet</i>.)

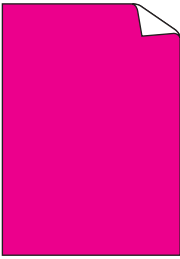
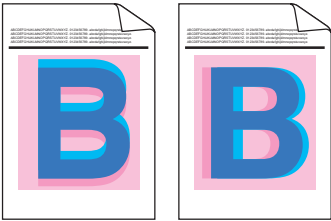
Examples of poor print quality	Recommendation
<p>Completely blank or some colors are missing</p> 	<ul style="list-style-type: none"> ■ Put in a new toner cartridge. (See <i>Replacing a Toner cartridge</i> on page 37.) To identify the color of the toner cartridge, visit us at http://solutions.brother.com/ to view our FAQs and troubleshooting tips. ■ Put in a new drum unit. (See <i>Replacing the drum unit</i> on page 44.)
<p>Colored spots at 94 mm</p> 	<ul style="list-style-type: none"> ■ If the problem is not solved after printing, the drum may have foreign material, such as glue from a label, stuck on the drum surface. Clean the drum unit. (See <i>Cleaning the drum unit</i> on page 69.) ■ Put in a new drum unit. (See <i>Replacing the drum unit</i> on page 44.)
<p>Colored spots at 30 mm</p> 	<ul style="list-style-type: none"> ■ Identify the color causing the problem and put in a new toner cartridge. (See <i>Replacing a Toner cartridge</i> on page 37.) To identify the color of the toner cartridge, visit us at http://solutions.brother.com/ to view our FAQs and troubleshooting tips.
<p>Toner scatter or toner stain</p> 	<ul style="list-style-type: none"> ■ Check the machine's environment. Conditions such as high humidity and high temperatures may cause this print quality problem. (See <i>Choosing a location</i> in the <i>Safety and Legal Booklet</i>.) ■ Identify the color causing the problem and put in a new toner cartridge. (See <i>Replacing a Toner cartridge</i> on page 37.) To identify the color of the toner cartridge, visit us at http://solutions.brother.com/ to view our FAQs and troubleshooting tips. ■ If the problem continues, put in a new drum unit. (See <i>Replacing the drum unit</i> on page 44.)

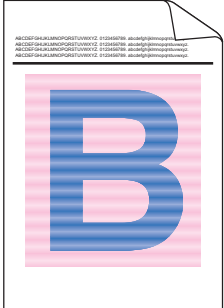
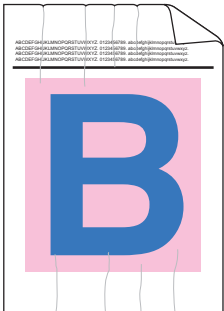
Examples of poor print quality	Recommendation
<p>The color of your printouts is not what you expected</p>	<ul style="list-style-type: none"> ■ Make sure Toner Save mode is off in the control panel of the machine or the printer driver. ■ Perform the calibration. (See <i>Calibration</i> on page 76.) ■ Adjust the color by using the custom setting in the printer driver and by using the control panel of the machine. Colors the machine can print and colors you see on a monitor are different. The machine may not be able to reproduce the colors on your monitor. ■ If colors appear in the printed gray areas, make sure there is a check in the Improve Gray Color check box of the printer driver. (See <i>Basic tab</i> for Windows® printer driver, <i>Advanced tab</i> for Macintosh printer driver or <i>Features</i> for Macintosh BR-Script printer driver in the <i>Software User's Guide</i>.) ■ If shaded areas look dull, remove the check from the Improve Gray Color check box. ■ If a printed black graphic is too light, choose Enhance Black Printing mode in the printer driver. (See <i>Settings Dialog</i> for Windows® printer driver, <i>Advanced options</i> for Windows® BR-Script printer driver, <i>Print Settings</i> for Macintosh printer driver or <i>Printer Features</i> for Macintosh BR-Script printer driver in the <i>Software User's Guide</i>.) ■ Identify the color causing the problem and put in a new toner cartridge. (See <i>Replacing a Toner cartridge</i> on page 37.) ■ Put in a new drum unit. (See <i>Replacing the drum unit</i> on page 44.)
<p>All one color</p> 	<ul style="list-style-type: none"> ■ Put in a new drum unit. (See <i>Replacing the drum unit</i> on page 44.)
<p>Color misregistration</p> 	<ul style="list-style-type: none"> ■ Make sure that the machine is on a solid level surface. ■ Perform the auto color registration using the control panel (see <i>Auto Registration</i> on page 77) or perform the manual color registration using the control panel (see <i>Manual Registration</i> on page 77). ■ Put in a new drum unit. (See <i>Replacing the drum unit</i> on page 44.) ■ Put in a new belt unit. (See <i>Replacing the belt unit</i> on page 49.)

Examples of poor print quality	Recommendation
<p>Uneven density appears periodically across the page</p> 	<ul style="list-style-type: none"> ■ Perform the calibration. (See <i>Calibration</i> on page 76.) ■ Adjust the contrast or brightness when you are in copy mode. (See <i>Adjusting Contrast, Color and Brightness</i> in Chapter 3 of the <i>Advanced User's Guide</i>.) ■ Identify the color that is uneven and put in a new toner cartridge for that color. (See <i>Replacing a Toner cartridge</i> on page 37.) To identify the color of the toner cartridge, visit us at http://solutions.brother.com/ to view our FAQs and troubleshooting tips. ■ Put in a new drum unit. (See <i>Replacing the drum unit</i> on page 44.)
<p>Thin lines do not print</p>	<ul style="list-style-type: none"> ■ Make sure Toner Save mode is off in the control panel of the machine or the printer driver. ■ Change the print resolution. ■ If you use a Windows® printer driver, choose Improve Pattern Printing or Improve Thin Line in Settings from the Basic tab. (See <i>Settings Dialog</i> in the <i>Software User's Guide</i>.)
<p>Wrinkle</p> 	<ul style="list-style-type: none"> ■ Change to the recommended type of paper. (See <i>Recommended paper and print media</i> on page 19 .) ■ Make sure that the back cover is closed properly. ■ Make sure that the two gray levers inside the back cover are in the up position. ■ Make sure that the media type settings in the printer driver and in the machine's Paper Type menu matches the type of paper you are using. (See <i>Acceptable paper and other print media</i> on page 19 and <i>Basic tab</i> in the <i>Software User's Guide</i>.)
<p>Offset image</p> 	<ul style="list-style-type: none"> ■ Make sure that the media type settings in the printer driver and in the machine's Paper Type menu matches the type of paper you are using. (See <i>Acceptable paper and other print media</i> on page 19 and <i>Basic tab</i> in the <i>Software User's Guide</i>.) ■ Make sure that the two gray levers inside the back cover are in the up position. ■ Check the machine's environment. Conditions such as low humidity and low temperatures may cause this print quality problem. (See <i>Choosing a location</i> in the <i>Safety and Legal Booklet</i>.) ■ Put in a new drum unit. (See <i>Replacing the drum unit</i> on page 44.)

B

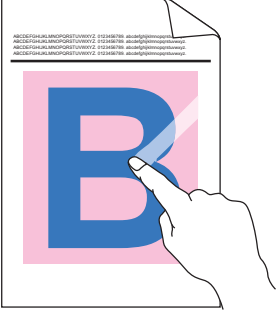
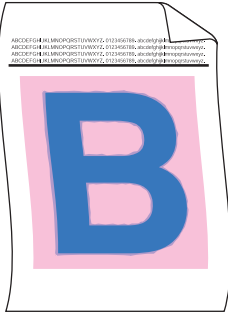
Examples of poor print quality	Recommendation
<p>Poor fixing</p> 	<ul style="list-style-type: none"> ■ Make sure that the media type settings in the printer driver and in the machine's Paper Type menu matches the type of paper you are using. (See <i>Acceptable paper and other print media</i> on page 19 and <i>Basic tab</i> in the <i>Software User's Guide</i>.) ■ Make sure that the two gray levers inside the back cover are in the up position. ■ Choose Improve Toner Fixing mode in the printer driver. (See <i>Other Print Options</i> (For Windows® printer driver), <i>Advanced options</i> (For Windows® BR-Script printer driver), <i>Print Settings</i> (For Macintosh printer driver) or <i>Printer Features</i> (For Macintosh BR-Script printer driver) in the <i>Software User's Guide</i>.) If this selection does not provide enough improvement, change the printer driver setting in Media Type to a thick setting.
<p>Curled or wavy</p> 	<ul style="list-style-type: none"> ■ Choose Reduce Paper Curl mode in the printer driver when you do not use our recommended paper. (See <i>Other Print Options</i> (For Windows® printer driver), <i>Advanced options</i> (For Windows® BR-Script printer driver), <i>Print Settings</i> (For Macintosh printer driver) or <i>Printer Features</i> (For Macintosh BR-Script printer driver) in the <i>Software User's Guide</i>.) ■ If you do not use the machine often, the paper may have been in the paper tray too long. Turn over the stack of paper in the paper tray. Also, fan the paper stack and then rotate the paper 180° in the paper tray. ■ Store the paper where it will not be exposed to avoid high temperatures and high humidity. ■ Open the back cover (face-up output tray) to let the printed paper out on the back output tray.

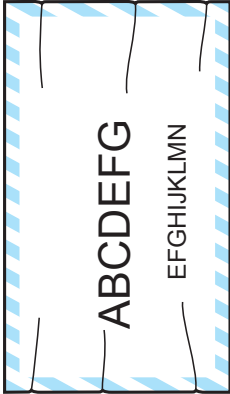
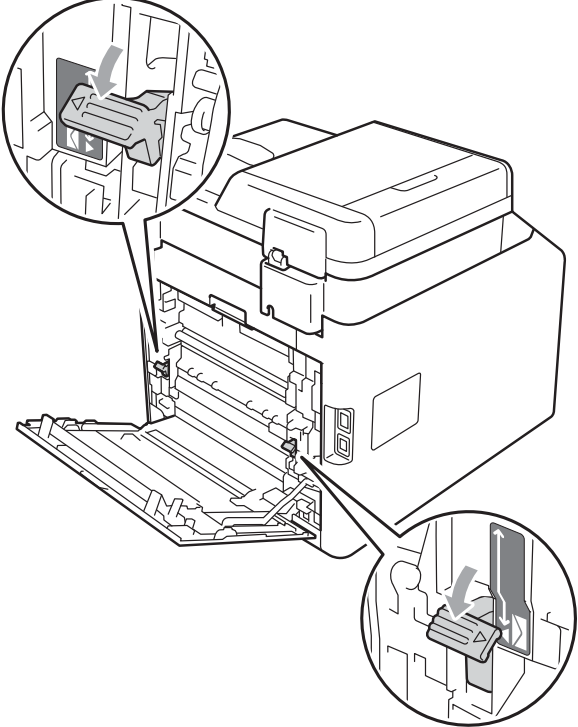
Examples of poor print quality	Recommendation
<p data-bbox="164 338 391 367">Envelope creases</p> 	<ul style="list-style-type: none"> <li data-bbox="587 338 1404 405">■ Make sure that the envelope lever is pulled down when you are printing envelopes.  <ul style="list-style-type: none"> <li data-bbox="587 1193 1433 1292">■ If creases occur with the envelope levers in the envelope position, print with the back cover opened and feed one envelope at a time from the MP tray.

Machine Information

Checking the Serial Number

You can see the machine's Serial Number on the LCD.

- 1 Press **Menu**, **5**, **2**.
- 2 Press **Stop/Exit**.

Reset functions

The following reset functions are available:

1 Network

You can reset the print server back to its default factory settings such as the password and IP address information.

2 All Settings

You can reset all the machine settings back to the settings that were set at the factory.

Brother strongly recommends you perform this operation when you dispose of the machine.



Note

Unplug the interface cable before you choose **Network** or **All Settings**.

How to reset the machine

- 1 Press **Menu**, **1**, **8**.
- 2 Press **▲** or **▼** to choose the reset function you want to use.
Press **OK**.
- 3 Do one of the following;
 - To reset the settings, press **1** and go to step 4.
 - To exit without making changes, press **2** and go to step 5.

- 4 You will be asked to reboot the machine. Do one of the following;
 - To reboot the machine press **1**. The machine will begin the reset.
 - To exit without rebooting the machine, press **2**. Go to step 5.

- 5 Press **Stop/Exit**.



Note

You can also reset the Network settings by pressing **Menu**, **4**, **0**.

On-screen programming

Your machine has been designed to be easy to use. The LCD provides on-screen programming using the menu keys.

We have created step by step on-screen instructions to help you program your machine. Simply follow the steps as they guide you through the menu selections and programming options.

How to access the menu mode

- 1 Press **Menu**.
- 2 Choose an option.
 - Press **1** for General Setup menu.
 - Press **2** for Copy menu.
 - Press **3** for Printer menu.
 - Press **4** for Network menu.
 - Press **5** for Machine Info. menu.

You can also scroll through each menu level by pressing ▲ or ▼ for the direction you want.

- 3 Press **OK** when the option you want appears on the LCD.
The LCD will then show the next menu level.
- 4 Press ▲ or ▼ to scroll to your next menu selection.
- 5 Press **OK**.
When you have finished setting an option, the LCD will show *Accepted*.
- 6 Press **Stop/Exit** to exit Menu mode.

Menu table

The factory settings are shown in Bold with an asterisk.

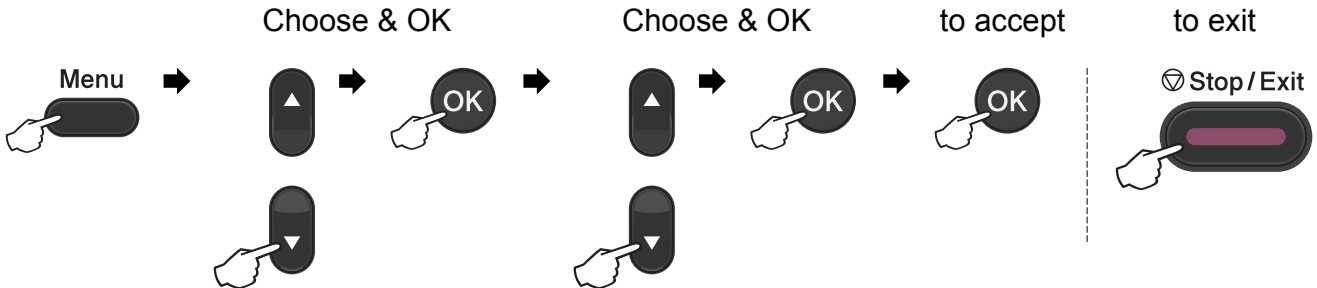

Level 1	Level 2	Level 3	Level 4	Options	Descriptions	Page
1. General Setup	1. Paper	1. Paper Type	1. MP Tray	Thin Plain* Thick Thicker Recycled Paper Glossy Paper	Sets the type of paper in the paper tray.	18
			2. Tray#1	Thin Plain* Thick Thicker Recycled Paper	Sets the type of paper in the paper tray.	18
			3. Tray#2 (This menu only appears if you have the optional tray#2.)	Thin Plain* Thick Thicker Recycled Paper	Sets the type of paper in the paper tray.	18
¹ See <i>Advanced User's Guide</i> . ² See <i>Quick Setup Guide</i> . ³ See <i>Software User's Guide</i> .						
 The factory settings are shown in Bold with an asterisk.						

Level 1	Level 2	Level 3	Level 4	Options	Descriptions	Page
1. General Setup (Continued)	1. Paper (Continued)	2. Paper Size	1. MP Tray	A4* Letter Legal Executive A5 A5 L A6 B5 B6 Folio 16K (195x270mm) 16K (184x260mm) 16K (197x273mm) Any	Sets the size of the paper in the paper tray.	18
			2. Tray#1	A4* Letter Legal Executive A5 A5 L A6 B5 B6 Folio	Sets the size of the paper in the paper tray.	18
			3. Tray#2 (This menu only appears if you have the optional tray#2.)	A4* Letter Legal Executive A5 B5 B6 Folio	Sets the size of the paper in the paper tray.	18
	2. Beeper	—	—	Off Low Med* High	Adjusts the volume level of the beeper.	9
¹ See <i>Advanced User's Guide</i> . ² See <i>Quick Setup Guide</i> . ³ See <i>Software User's Guide</i> .						
 The factory settings are shown in Bold with an asterisk.						

Level 1	Level 2	Level 3	Level 4	Options	Descriptions	Page
1. General Setup (Continued)	3. Ecology	1. Toner Save	—	On Off*	Increases the page yield of the toner cartridge.	See ¹ .
		2. Sleep Time	—	Range varies depending on models. 003Min*	Conserves power.	
	4. Tray Use	1. Copy	—	Tray#1 Only Tray#2 Only MP Only MP>T1>T2* T1>T2>MP (Tray#2 or T2 appears only if you installed the optional paper tray.)	Chooses the tray that will be used for Copy mode.	18
		2. Print	—	Tray#1 Only Tray#2 Only MP Only MP>T1>T2* T1>T2>MP (Tray#2 or T2 appears only if you installed the optional paper tray.)	Chooses the tray that will be used for Print mode.	19
	5. LCD Contrast	—	—	-□□□□■+ -□□□■+ -□□■□□+* -□■□□□+ -■□□□□+	Adjusts the contrast of the LCD.	See ¹ .

¹ See *Advanced User's Guide*.

² See *Quick Setup Guide*.

³ See *Software User's Guide*.



The factory settings are shown in Bold with an asterisk.

Level 1	Level 2	Level 3	Level 4	Options	Descriptions	Page
1. General Setup (Continued)	6. Function Lock	—	—	—	Can restrict selected machine operation for up to 25 individual users and all other non-authorized Public users.	See ¹ .
	7. Document Scan	1. Glass ScanSize	—	A4* Letter	Adjusts the scan area of the scanner glass to the size of the document.	See ³ .
		2. File Size	1. Color	Small Middle* Large	You can set your own default settings of the data compression rate.	See ³ .
			2. Gray	Small Middle* Large		
	8. Reset	1. Network	—	1. Reset 2. Exit	Restores all network settings to factory default.	104
		2. All Settings	—	1. Reset 2. Exit	Restores all the machine settings to factory default.	
	0. Local Language	—	—	(Choose your language.)	Allows you to change the LCD language for your country.	See ² .
¹ See <i>Advanced User's Guide</i> . ² See <i>Quick Setup Guide</i> . ³ See <i>Software User's Guide</i> .						
 The factory settings are shown in Bold with an asterisk.						

Level 1	Level 2	Level 3	Options	Descriptions	Page
2. Copy	1. Quality	—	Auto* Text Photo Graph	You can choose the Copy resolution for your type of document.	See 1.
	2. Brightness	—	-□□□□■+ -□□□■□+ -□□■□□+* -□■□□□+ -■□□□□+	Adjust the brightness for copies.	
	3. Contrast	—	-□□□□■+ -□□□■□+ -□□■□□+* -□■□□□+ -■□□□□+	Adjusts the contrast for copies.	
	4. Color Adjust	1. Red	-□□□□■+ -□□□■□+ -□□■□□+* -□■□□□+ -■□□□□+	Adjusts the red color for copies.	
		2. Green	-□□□□■+ -□□□■□+ -□□■□□+* -□■□□□+ -■□□□□+	Adjusts the green color for copies.	
		3. Blue	-□□□□■+ -□□□■□+ -□□■□□+* -□■□□□+ -■□□□□+	Adjusts the blue color for copies.	
¹ See <i>Advanced User's Guide</i> .					
 The factory settings are shown in Bold with an asterisk.					

Level 1	Level 2	Level 3	Options	Descriptions	Page
3. Printer	1. Emulation	—	Auto* HP LaserJet BR-Script 3	Chooses the emulation mode.	See ¹ .
	2. Print Options	1. Internal Font	1. HP LaserJet 2. BR-Script 3	Prints a list of the machine's internal fonts.	
		2. Configuration	—	Prints a list of the machine's printer settings.	
		3. Test Print	—	Prints a test page.	
	3. Duplex	—	Off* On (Long Edge) On (Short Edge)	Enables or disables duplex printing. You can also choose long edge or short edge duplex printing.	
	4. Output Color	—	Auto* Color B&W	Chooses color or black & white printed documents. If you choose Auto, the machine selects a suitable option for the document (Color or B&W).	
	5. Reset Printer	—	1. Reset 2. Exit	Restores the printer settings to the original factory default settings.	
	6. Calibration	—	Calibrate Reset	Adjusts the color density or returns the color calibration to the factory settings.	76
7. Auto Regist.	—	1. Start 2. Exit	Adjust the print position of each color automatically.	77	
¹ See <i>Software User's Guide</i> .					
 The factory settings are shown in Bold with an asterisk.					

Level 1	Level 2	Level 3	Options	Descriptions	Page
3. Printer (Continued)	8. Manual Regist.	1. Print Chart	—	Print the chart to manually check the registration of the colors.	77
		2. Set Regist.	1 Magenta Left 2 Cyan Left 3 Yellow Left 4 Magenta Center 5 Cyan Center 6 Yellow Center 7 Magenta Right 8 Cyan Right 9 Yellow Right	Sets the correction value on the chart you printed from Print Chart.	
	9. Frequency	—	Normal* Low Off	Sets the interval time you want to carry out the auto registration and the calibration.	77

¹ See Software User's Guide.



The factory settings are shown in Bold with an asterisk.

Level 1	Level 2	Level 3	Level 4	Options	Descriptions
4. Network	1. TCP/IP	1. Boot Method	—	Auto* Static RARP BOOTP DHCP	Chooses the BOOT method that best suits your needs.
		2. IP Address	—	[000-255]. [000-255]. [000-255]. [000-255]	Enter the IP address.
		3. Subnet Mask	—	[000-255]. [000-255]. [000-255]. [000-255]	Enter the Subnet mask.
		4. Gateway	—	[000-255]. [000-255]. [000-255]. [000-255]	Enter the Gateway address.
		5. Node Name	—	BRNXXXXXXXXXXXX	Enter the Node name.
		6. WINS Config	—	Auto* Static	Chooses the WINS configuration mode.
		7. WINS Server	—	Primary [000-255]. [000-255]. [000-255]. [000-255] Secondary [000-255]. [000-255]. [000-255]. [000-255]	Specifies the IP address of the primary or secondary WINS server.
		8. DNS Server	—	Primary [000-255]. [000-255]. [000-255]. [000-255] Secondary [000-255]. [000-255]. [000-255]. [000-255]	Specifies the IP address of the primary or secondary DNS server.
		9. APIPA	—	On* Off	Automatically allocates the IP address from the link-local address range.
		0. IPv6	—	On Off*	Enable or Disable the IPv6 protocol. If you want to use the IPv6 protocol, visit http://solutions.brother.com/ for more information.
See <i>Network User's Guide</i> .					
 The factory settings are shown in Bold with an asterisk.					

Level 1	Level 2	Level 3	Level 4	Options	Descriptions	
4. Network (Continued)	2. Ethernet	—	—	Auto* 100B-FD 100B-HD 10B-FD 10B-HD	Chooses the Ethernet link mode.	
	3. Status	—	—	Active 100B-FD Active 100B-HD Active 10B-FD Active 10B-HD Inactive	Shows the Ethernet link status.	
	4. MAC Address	—	—	—	Shows the MAC address of the machine.	
	5. Scan To FTP	—	—	Color 100 dpi* Color 200 dpi Color 300 dpi Color 600 dpi Gray 100 dpi Gray 200 dpi Gray 300 dpi B&W 200 dpi B&W 200x100 dpi	Chooses the file format to send the scanned data via FTP.	
	6. ScanTo Network	—	—	Color 100 dpi* Color 200 dpi Color 300 dpi Color 600 dpi Gray 100 dpi Gray 200 dpi Gray 300 dpi B&W 200 dpi B&W 200x100 dpi	You can scan a black and white or color document directly to a CIFS server on your local network or on the internet.	
	0. Network Reset	1. Reset	—	—	1. Yes 2. No	Restore all network settings to factory default.
		2. Exit	—	—	—	
See <i>Network User's Guide</i> .						
 The factory settings are shown in Bold with an asterisk.						

Level 1	Level 2	Level 3	Options	Descriptions	Page	
5. Machine Info.	1. Date&Time	1. Date&Time	—	Puts the date and time on the LCD.	See ² .	
		2. Time Zone	UTCXXX:XX	Sets the time zone for your country.	See ³ .	
	2. Serial No.	—	—	You can check the serial number of your machine.	104	
	3. Page Counter	—	Total List Copy Print	You can check the number of total pages the machine has printed during its life.	See ¹ .	
	4. User Settings	—	—	Lists your settings.		
	5. Network Config	—	—	Lists your Network settings.		
	6. Drum Dot Print	—	—	—	Prints the drum dot check sheet.	69
	7. Parts Life	1. Drum	—	—	You can check the percentage of a machine part's life that remains available. (PF Kit 2 appears only if you installed the optional paper tray.)	See ¹ .
		2. Belt Unit	—	—		
		3. Fuser	—	—		
4. Laser		—	—			
5. PF Kit MP		—	—			
6. PF Kit 1		—	—			
7. PF Kit 2		—	—			
¹ See <i>Advanced User's Guide</i> . ² See <i>Quick Setup Guide</i> . ³ See <i>Network User's Guide</i> .						
 The factory settings are shown in Bold with an asterisk.						

Entering text

When setting certain menu selections, you will need to type text characters. The numeric keys have letters printed on them. The keys: **0**, **#** and ***** do *not* have printed letters because they are used for special characters.

Press the appropriate numeric key the number of times shown in this reference table to access the character you want.

Press Key	one time	two times	three times	four times	five times	six times	seven times	eight times	nine times
1	@	.	/	1	@	.	/	1	@
2	a	b	c	A	B	C	2	a	b
3	d	e	f	D	E	F	3	d	e
4	g	h	i	G	H	I	4	g	h
5	j	k	l	J	K	L	5	j	k
6	m	n	o	M	N	O	6	m	n
7	p	q	r	s	P	Q	R	S	7
8	t	u	v	T	U	V	8	t	u
9	w	x	y	z	W	X	Y	Z	9

For menu selections that do not allow lower case character selection, please use this reference table.

Press Key	one time	two times	three times	four times	five times
2	A	B	C	2	A
3	D	E	F	3	D
4	G	H	I	4	G
5	J	K	L	5	J
6	M	N	O	6	M
7	P	Q	R	7	P
8	T	U	V	8	T
9	W	X	Y	9	W

Inserting spaces

To enter a space in a number, press **▶** once between numbers. To enter a space in a name, press **▶** twice between characters.

Making corrections

If you entered a letter incorrectly and want to change it, press **◀** or **▶** to move the cursor to the incorrect character, and then press **Clear**.

Repeating letters

To enter a character on the same key as the previous character, press **▶** to move the cursor right before pressing the key again.

Special characters and symbols

Press *, # or 0, then press ◀ or ▶ to move the cursor to the symbol or character you want. Press **OK** to choose it. The symbols and characters below will appear depending on your menu selection.

Press *	for	(space) ! " # \$ % & ' () * + , - . /
Press #	for	: ; < = > ? @ [] ^ _ \ ~ ' { }
Press 0	for	Ä Ë Ö Ü À Ç È É 0

Conversion and Enter Characters

You can register your name in Chinese or English in this machine, you can switch between the alphabet input mode and the Chinese-entry mode by pressing ▲ button, the current input mode will appear in the lower right corner of LCD. Simplified Chinese can be converted from Pinyin entry.

For example, if you want to enter “Good 公司”, follow the below procedures:

- 1 Make sure you are in the alphabet input mode.
 ▲A will appear in the lower right corner.
 Press [4 out] repeatedly until showing G, and press ▶.
 By pressing the correct button repeatedly, you can access the character you want, and press ▶.
 If you need to enter a letter that is NOT on the same button as the letter before it, you needn't press ▶, just press the correct button.
- 2 Press ▲ to enter the Chinese-entry mode.
 ▲拼 will appear in the lower right corner.
 Press [4 out] one time until showing Pinyin g, and press ▶, the cursor move to the next.
 By pressing the correct button repeatedly, you can access the Pinyin you want.
 In actual operation of entering Pinyin, some Chinese words and phrases appear in the lower part of LCD, then press ▼, the cursor come to this lower part.
- 3 Press ▲, ▼, ◀ or ▶ to move the cursor to choose “公司” which you exactly want.
 Press **OK** to complete.

During the above operation, you can press  to erase the character above the cursor.

General

Printer Type	Laser	
Print Method	Electrophotography by semiconductor laser beam scanning	
Memory Capacity	128 MB	
LCD (liquid crystal display)	15 characters × 5 lines (2 bytes)	
Power Source	220 - 240 V AC 50/60Hz	
Power Consumption ¹	Peak:	1200 W
	Copying (Average):	Approx. 570 W ²
	Deep Sleep (Average):	Approx. 1.2 W
	Ready (Average):	Approx. 70 W

¹ USB connection to PC

² When making a copy from one sheet

Dimensions

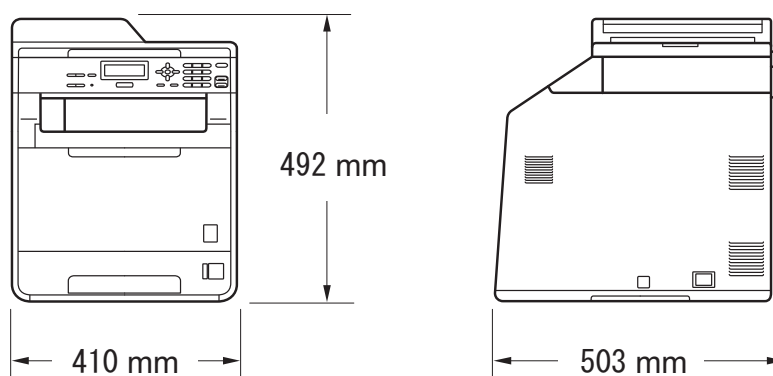

Weight	With Consumables:	26.5 kg
---------------	-------------------	---------

Noise level	Sound power	
	Operating (Color Printing):	LWAd = 6.82 B (A)
	Operating (Monochrome Printing):	LWAd = 6.74 B (A)
	Standby:	LWAd = 4.8 B (A)

Sound pressure

Operating (Printing): LPAm = 57 dB (A)

Standby: LPAm = 33 dB (A)

Temperature

Operating: 10 to 32.5°C

Storage: 0 to 40°C

Humidity

Operating: 20 to 80% (without condensation)

Storage: 10 to 90% (without condensation)

ADF (automatic document feeder)Up to 35 pages (Staggered) [80 g/m²]

Document Size

**Document Size
(Single-sided)**

ADF Width: 147.3 to 215.9 mm
ADF Length: 147.3 to 356.0 mm
Scanner Glass Width: Max. 215.9 mm
Scanner Glass Length: Max. 297 mm

Print media

Paper Input	Paper Tray	
	■ Paper Type:	Plain paper, Thin paper or Recycled paper
	■ Paper Size:	Letter, A4, B5 (ISO/JIS), A5, A5 (Long Edge), B6 (ISO), A6, Executive, Legal and Folio
	■ Paper Weight:	60 to 105 g/m ²
	■ Maximum Paper Tray Capacity:	Up to 250 sheets of 80 g/m ² Plain paper
	Multi-purpose tray (MP tray)	
	■ Paper Type:	Envelope, Env.Thin, Env.Thick, Labels ¹ , Glossy paper, Thin paper, Thick paper, Thicker paper, Recycled paper, Bond paper or Plain paper
	■ Paper Size:	Width: 69.8 to 216 mm Length: 116 to 406.4 mm
	■ Paper Weight:	60 to 163 g/m ² ²
	■ Maximum Paper Tray Capacity:	Up to 50 sheets of 80 g/m ² Plain paper
	Paper Tray 2 (option)	
	■ Paper Type:	Plain paper, Thin paper or Recycled paper
	■ Paper Size:	Letter, A4, B5 (ISO/JIS), A5, B6 (ISO), Executive, Legal and Folio
	■ Paper Weight:	60 to 105 g/m ²
	■ Maximum Paper Tray Capacity:	Up to 500 sheets of 80 g/m ² Plain paper
Paper Output	Face-Down Output Tray	Up to 150 sheets (face-down print delivery to the output paper tray)
	Face-Up Output Tray	One sheet (face-up print delivery to the Face-up output tray)

Duplex Printing

■ Manual Duplex:	Yes
■ Automatic Duplex:	Yes
■ Paper Size (Automatic Duplex):	A4
■ Paper Weight (Automatic Duplex):	60 to 105 g/m ²
■ Paper Type (Automatic Duplex):	Plain paper, Thin paper, Recycled paper or Glossy paper

¹ For labels, we recommend removing printed pages from the output paper tray immediately after they exit the machine to avoid the possibility of smudging.

² 60 to 105 g/m² for duplex print.

Copy

Color/Black	Yes/Yes
Copy Width	Max. 210 mm
Multiple Copies	Stacks or Sorts up to 99 pages
Reduce/Enlarge	25% to 400% (in increments of 1%)
Resolution	Up to 1200 × 600 dpi
First Copy Out Time (Monochrome)	Less than 19 seconds (from the READY mode and standard tray)
First Copy Out Time (Color)	Less than 21 seconds (from the READY mode and standard tray)

Scanner

Color/Black	Yes/Yes
TWAIN Compliant	Yes (Windows® 2000 Professional/Windows® XP/ Windows® XP Professional x64 Edition/Windows Vista®/ Windows® 7) Mac OS X 10.4.11 – 10.6.x ¹
WIA Compliant	Yes (Windows® XP/Windows Vista®/Windows® 7)
Color Depth	48 bit internal / 24 bit external color
Resolution	Up to 19200 × 19200 dpi (interpolated) ² Up to 1200 × 2400 dpi (optical) ² (from Scanner Glass) Up to 1200 × 600 dpi (optical) ² (from ADF)
Scanning Width	Max. 210 mm
Grayscale	256 levels

¹ For the latest driver updates for the Mac OS X you are using, visit us at <http://solutions.brother.com/>.

² Maximum 1200 × 1200 dpi scanning with the WIA driver in Windows® XP (resolution up to 19200 × 19200 dpi can be chosen by using the scanner utility)

Printer

Automatic 2-sided (Duplex) Print	Yes
Emulations	PCL6, BR-Script3 (PostScript® 3™)
Resolution	600 dpi × 600 dpi, 2400 dpi (2400 × 600) quality
Print Speed (Monochrome Duplex)	Up to 14 sides/minute (Up to 7 sheets/minute) (A4 size)
Print Speed (Color Duplex)	Up to 14 sides/minute (Up to 7 sheets/minute) (A4 size)
Print Speed (Monochrome)	Up to 24 pages/minute (A4 size) ¹
Print Speed (Color)	Up to 24 pages/minute (A4 size) ¹
First Print Out Time (Monochrome)	Less than 16 seconds (from the READY mode and standard tray)
First Print Out Time (Color)	Less than 16 seconds (from the READY mode and standard tray)

¹ The print speed may change depending on the type of document you print.

Interfaces

USB It is recommended to use a USB 2.0 cable (Type A/B) that is no more than 2 meters long. ^{1 2}

Ethernet ³ Use an Ethernet UTP cable category 5 or greater.

¹ Your machine has a Hi-Speed USB 2.0 interface. The machine can also be connected to a computer that has a USB 1.1 interface.

² Third party USB ports are not supported.

³ See *Network (LAN)* on page 130 and the Network User's Guide for detailed network specifications.

Computer requirements

Minimum System Requirements and Supported PC Software Functions								
Computer Platform & Operating System Version		Processor Minimum Speed	Minimum RAM	Recommended RAM	Hard Disk Space to install		Supported PC Software Functions	Supported PC Interface ³
					For Drivers	For Applications		
Windows® Operating System ¹	Windows® 2000 Professional	Intel® Pentium® II or equivalent	64 MB	256 MB	150 MB	500 MB	Printing, Scanning	USB, 10/100 Base Tx (Ethernet)
	Windows® XP Home ^{2 4} Windows® XP Professional ^{2 4}		128 MB					
	Windows® XP Professional x64 Edition ^{2 4}	64-bit (Intel® 64 or AMD64) supported CPU	256 MB	512 MB				
	Windows Vista® ⁴	Intel® Pentium® 4 or equivalent 64-bit (Intel® 64 or AMD64) supported CPU	512 MB	1 GB	500 MB	1.2 GB		
	Windows® 7 ⁴	Intel® Pentium® 4 or equivalent 64-bit (Intel® 64 or AMD64) supported CPU	1 GB (32-bit)	1 GB (32-bit)	650 MB			
			2 GB (64-bit)	2 GB (64-bit)				

Minimum System Requirements and Supported PC Software Functions

Computer Platform & Operating System Version		Processor Minimum Speed	Minimum RAM	Recommended RAM	Hard Disk Space to install		Supported PC Software Functions	Supported PC Interface ³
					For Drivers	For Applications		
Windows® Operating System ¹	Windows Server® 2003 (print only via network)	Intel® Pentium® III or equivalent	256 MB	512 MB	50 MB	N/A	Printing	10/100 Base Tx (Ethernet)
	Windows Server® 2003 x64 Edition (print only via network)	64-bit (Intel®64 or AMD64) supported CPU						
	Windows Server® 2008 (print only via network)	Intel® Pentium® 4 or equivalent 64-bit (Intel®64 or AMD64) supported CPU	512 MB	2 GB				
	Windows Server® 2008 R2 (print only via network)	64-bit (Intel®64 or AMD64) supported CPU						
Macintosh Operating System	Mac OS X 10.4.11 10.5.x	PowerPC G4/G5 Intel® Core™ Processor	512 MB	1 GB	80 MB	400 MB	Printing, Scanning	USB, 10/100 Base Tx (Ethernet)
	Mac OS X 10.6.x	Intel® Core™ Processor	1 GB	2 GB				

¹ Internet Explorer® 6.0 or greater.

² For WIA, 1200 x 1200 resolution. Brother Scanner Utility enables to enhance up to 19200 x 19200 dpi.

³ Third party USB ports are not supported.

⁴ Presto! PageManager on the CD-ROM supports Microsoft® Windows® 2000, Windows® XP, Windows Vista® and Windows® 7.

For the latest driver updates, visit <http://solutions.brother.com/>.

All trademarks, brand and product names are property of their respective companies.

Consumable items

Toner Cartridge Life	Standard Toner Cartridge:	
	TN-370BK (Black):	Approx. 2,500 pages (A4) ¹
	TN-370C (Cyan):	Approx. 1,500 pages (A4) ¹
	TN-370M (Magenta):	Approx. 1,500 pages (A4) ¹
	TN-370Y (Yellow):	Approx. 1,500 pages (A4) ¹
	High Capacity Toner Cartridge:	
	TN-378BK (Black):	Approx. 6,000 pages (A4) ¹
	TN-375C (Cyan):	Approx. 3,500 pages (A4) ¹
	TN-375M (Magenta):	Approx. 3,500 pages (A4) ¹
	TN-375Y (Yellow):	Approx. 3,500 pages (A4) ¹
Drum Unit	DR-370CL	Approx. 25,000 pages (A4) ²
Belt Unit	BU-300CL	Approx. 50,000 pages (A4)
Waste Toner Box	WT-300CL	Approx. 50,000 pages (A4)

¹ Approx. cartridge yield is declared in accordance with ISO/IEC 19798.

² Drum yield is approximate, and may vary by type of use.



Note

- Brother does not recommend the use of consumables other than genuine Brother consumables.
- Your machine warranty may not cover any damage arising from the use of non genuine Brother consumables.

Network (LAN)



Note

For details about the full Network specifications, see *Network User's Guide*.

LAN

You can connect your machine to a network for Network Printing and Network Scanning ¹. Also included is Brother BRAdmin Light ² Network Management software.

Wired Network Security

APOP, POP before SMTP, SMTP-AUTH, SSL/TLS (IPPS, HTTPS, SMTP, POP), SNMP v3, 802.1x (EAP-MD5, EAP-FAST, PEAP, EAP-TLS, EAP-TTLS), Kerberos

¹ See *Computer requirements* on page 127.

² BRAdmin Professional and Web BRAdmin are available as a download from <http://solutions.brother.com/>.

E

Index

A

- ADF (automatic document feeder)
 - using24
- Apple Macintosh
 - See Software User's Guide.

B

- Belt unit
 - replacing49

C

- Cleaning
 - corona wires66
 - drum unit69
 - laser scanner windows62
 - scanner61
- Consumable items 34, 35, 36
- Control panel overview6
- ControlCenter2 (for Macintosh)
 - See Software User's Guide.
- ControlCenter4 (for Windows®)
 - See Software User's Guide.
- Copy
 - keys6

D

- Document
 - how to load 24, 25
- Drum unit
 - cleaning 66, 69
 - replacing43

E

- Envelopes13, 20, 21, 22
- Error messages on LCD78
 - Init Unable XX80
 - No Paper81
 - Out of Memory81
 - Print Unable XX81
 - Scan Unable XX82

F

- Folio 18, 20

G

- Grayscale 124

H

- HELP
 - LCD messages 105
 - Menu Table 106

L

- Labels12, 20, 22
- LCD (liquid crystal display) 6, 105

M

- Machine information
 - how to reset the machine 104
 - reset functions 104
 - serial number 104
 - status LED 8
- Macintosh
 - See Software User's Guide.
- Maintenance, routine 60
 - replacing
 - belt unit 49
 - drum unit 43
 - toner cartridge 37
 - waste toner box 54
- Menu Table 106
- Mode, entering
 - copy 26
 - scan 7

N

- Network
 - printing
 - See Network User's Guide.
 - scanning
 - See Software User's Guide.

O

Out of Memory message81

P

Paper 19, 121
 how to load 10
 in multi-purpose tray 12
 in paper tray 10
 recommended 19, 20
 size 18, 19
 tray capacity 20
 type 18, 19

Presto! PageManager
 See Software User's Guide. See also Help
 in the Presto! PageManager application.

Print
 difficulties 93
 drivers 125
 quality 95, 97
 resolution 125
 specifications 125

Printing
 See Software User's Guide.

Programming your machine 105

Q

Quality
 printing 95, 97

R

Replacing
 belt unit 49
 drum unit 43
 toner cartridge 37
 waste toner box 54

Resolution
 copy 123
 print 125
 scan 124

S

Scanner glass
 using 25

Scanning
 See Software User's Guide.

Secure key 7

Status LED 8

T

Text, entering 116

Toner cartridge
 replacing 37

Troubleshooting 93
 document jam 83, 84
 error messages on LCD 78
 if you are having difficulty
 copy quality 93
 network 96
 paper handling 95
 print quality 95, 97
 printing 93
 scanning 94
 software 94
 maintenance messages on LCD 78
 paper jam 84, 85, 86, 88, 91

V

Volume, setting
 beeper 9

W

Waste toner box
 replacing 54

Windows®
 See Software User's Guide.

brother[®]

The machine is approved for use in the country of purchase only, local Brother companies or their dealers will only support machines purchased in their own countries.

Free Manuals Download Website

<http://myh66.com>

<http://usermanuals.us>

<http://www.somanuals.com>

<http://www.4manuals.cc>

<http://www.manual-lib.com>

<http://www.404manual.com>

<http://www.luxmanual.com>

<http://aubethermostatmanual.com>

Golf course search by state

<http://golfingnear.com>

Email search by domain

<http://emailbydomain.com>

Auto manuals search

<http://auto.somanuals.com>

TV manuals search

<http://tv.somanuals.com>