

# Privia

ES

# PX-5S

## USER'S GUIDE (Basics) GUÍA DEL USUARIO (Conceptos básicos)

Please keep all information for future reference.

Guarde toda información para tener como referencia futura.

- You can download a separate tutorial manual from the CASIO website below.  
<http://world.casio.com/>
- El manual Tutorial por separado puede descargarse del siguiente sitio web de CASIO.  
<http://world.casio.com/>

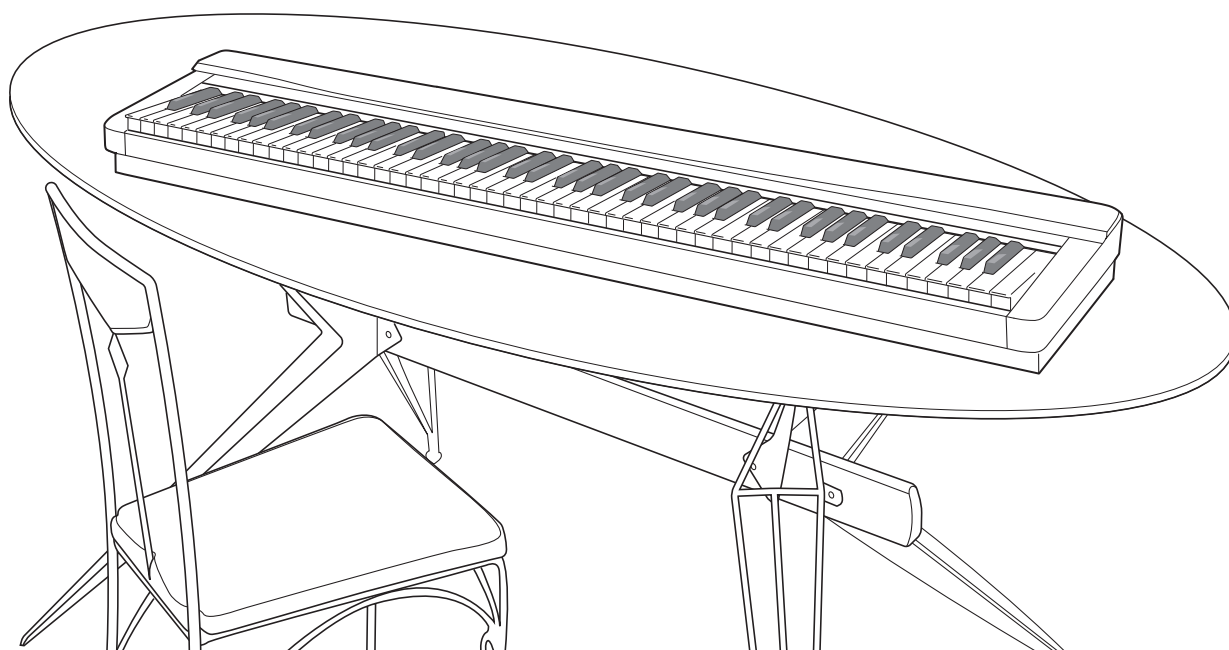

### **Safety Precautions**

Before trying to use the Digital Piano, be sure to read the separate "Safety Precautions".

### **Precauciones de seguridad**

Antes de intentar usar el piano digital, asegúrese de leer las "Precauciones de seguridad" separadas.

TO REDUCE THE RISK OF FIRE OR ELECTRIC SHOCK, REFER SERVICING TO QUALIFIED SERVICE PERSONNEL.

## IMPORTANT SAFETY INSTRUCTIONS

1. Read these instructions.
2. Keep these instructions.
3. Heed all warnings.
4. Follow all instructions.
5. Do not use this apparatus near water.
6. Clean only with dry cloth.
7. Do not block any ventilation openings. Install in accordance with the manufacturer's instructions.
8. Do not install near any heat sources such as radiators, heat registers, stoves, or other apparatus (including amplifiers) that produce heat.
9. Do not defeat the safety purpose of the polarized or grounding-type plug. A polarized plug has two blades with one wider than the other. A grounding type plug has two blades and a third grounding prong. The wide blade or the third prong are provided for your safety. If the provided plug does not fit into your outlet, consult an electrician for replacement of the obsolete outlet.
10. Protect the power cord from being walked on or pinched particularly at plugs, convenience receptacles, and the point where they exit from the apparatus.
11. Only use attachments/accessories specified by the manufacturer.
12. Use only with the cart, stand, tripod, bracket, or table specified by the manufacturer, or sold with the apparatus. When a cart is used, use caution when moving the cart/apparatus combination to avoid injury from tip-over.



13. Unplug this apparatus during lightning storms or when unused for long periods of time.
14. Refer all servicing to qualified service personnel. Servicing is required when the apparatus has been damaged in any way, such as power-supply cord or plug is damaged, liquid has been spilled or objects have fallen into the apparatus, the apparatus has been exposed to rain or moisture, does not operate normally, or has been dropped.

The apparatus shall not be exposed to dripping or splashing and that no objects filled with liquids, such as vases, shall be placed on the apparatus.

The  (POWER) indicator being unlit does not mean the apparatus is completely disconnected from the MAINS. When you need to have the apparatus completely disconnected from the MAINS, you must unplug the power cord. For that purpose, locate the apparatus in a way that secures easy access to the power cord.

## Declaration of Conformity

Model Number: PX-5S  
Trade Name: CASIO COMPUTER CO., LTD.  
Responsible party: CASIO AMERICA, INC.  
Address: 570 MT. PLEASANT AVENUE, DOVER, NEW JERSEY 07801  
Telephone number: 973-361-5400

This device complies with Part 15 of the FCC Rules, Operation is subject to the following two conditions:

(1) This device may not cause harmful interference, and (2) this device must accept any interference received, including interference that may cause undesired operation.

## NOTICE

This equipment has been tested and found to comply with the limits for a Class B digital device, pursuant to Part 15 of the FCC Rules. These limits are designed to provide reasonable protection against harmful interference in a residential installation. This equipment generates, uses and can radiate radio frequency energy and, if not installed and used in accordance with the instructions, may cause harmful interference to radio communications. However, there is no guarantee that interference will not occur in a particular installation. If this equipment does cause harmful interference to radio or television reception, which can be determined by turning the equipment off and on, the user is encouraged to try to correct the interference by one or more of the following measures:

- Reorient or relocate the receiving antenna.
- Increase the separation between the equipment and receiver.
- Connect the equipment into an outlet on a circuit different from that to which the receiver is connected.
- Consult the dealer or an experienced radio/TV technician for help.

## FCC WARNING

Changes or modifications not expressly approved by the party responsible for compliance could void the user's authority to operate the equipment.

## Important!

Please note the following important information before using this product.

- Before using the AD-A12150LW Adaptor to power the product, be sure to check the AC Adaptor for any damage first. Carefully check the power cord for breakage, cuts, exposed wire and other serious damage. Never let children use an AC adaptor that is seriously damaged.
- The product is not intended for children under 3 years.
- Use only the CASIO AD-A12150LW adaptor.
- The AC adaptor is not a toy.
- Be sure to disconnect the AC adaptor before cleaning the product.

Declaration of Conformity According to EU Directive



This mark applies in EU countries only.



Manufacturer:  
CASIO COMPUTER CO., LTD.  
6-2, Hon-machi 1-chome, Shibuya-ku, Tokyo 151-8543, Japan  
Responsible within the European Union:  
CASIO EUROPE GmbH  
Casio-Platz 1, 22848 Norderstedt, Germany

# Contents

## **General Guide..... E-2**

- Saving Settings and Using Panel Lock..... E-4
- Returning the Digital Piano to Its  
Factory Default Settings ..... E-4
- Separate Tutorial Manual ..... E-4

## **Power Outlet ..... E-5**

- Using an AC Adaptor ..... E-5
- Using Batteries ..... E-5
- Turning Power On or Off..... E-6

## **Connections..... E-7**

- Connecting Headphones ..... E-7
- Connecting a Pedal ..... E-7
- Connecting Audio Equipment or an Amplifier ..... E-8
- Bundled and Optional Accessories..... E-8

## **Operations Common to All Modes ..... E-9**

- Changing a Number or a Value ..... E-9
- Inputting Text Characters ..... E-10
- Saving Data ..... E-11
- Starting and Stopping Playback..... E-11
- Starting and Stopping Recording..... E-12
- Using the Editing Function..... E-13
- Meanings of Symbols Next to Numbers ..... E-13

## **Using Built-in Tones ..... E-14**

- Selecting a Tone ..... E-14
- Editing a Tone..... E-14
- Using the Bender Wheel..... E-15
- Modifying Notes with the Modulation Wheel,  
Knobs and Sliders..... E-15

## **Playing Demo Songs..... E-16**

## **Sounding Arpeggios Automatically..... E-17**

- To use the Arpeggio Function..... E-17

## **Recording and Playing Back Phrases..... E-18**

- Recording a New Phrase ..... E-18
- Listening to a Phrase ..... E-20
- Recording Over Another Phrase (Overdubbing)..... E-21
- To save a phrase ..... E-21
- Creating a Song (Song Sequencer)..... E-21

## **Recording Your Keyboard Play ..... E-23**

- Recording to a USB Flash Drive ..... E-23

## **Using the Stage Setups ..... E-26**

- Overview ..... E-26
- Recalling a Stage Setup..... E-26

## **Other Useful Functions..... E-27**

- System Settings ..... E-27
- Deleting Data ..... E-28

## **USB Flash Drive ..... E-29**

- Storing Standard Audio Data (WAV Files)  
to a USB Flash Drive..... E-30
- Connecting a USB Flash Drive to and  
Detaching It from the Digital Piano..... E-30
- Formatting a USB Flash Drive ..... E-31
- Saving Digital Piano Data to a USB Flash Drive..... E-32
- Loading Data from a USB Flash Drive to  
Digital Piano Memory ..... E-32
- Deleting Data from a USB Flash Drive..... E-33
- Renaming a USB Flash Drive File ..... E-33
- Playing Back Audio Data Stored on  
a USB Flash Drive..... E-34
- Playing Back a MIDI File Stored on  
a USB Flash Drive..... E-34
- Error Messages..... E-35

## **Connecting to a Computer .... E-36**

- Minimum Computer System Requirements ..... E-36
- Connecting the Digital Piano to Your Computer ..... E-36
- Saving and Loading Digital Piano Data  
to a Computer and Editing Digital Piano Data  
on a Computer ..... E-37

## **Reference ..... E-38**

- Troubleshooting ..... E-38
- Product Specifications..... E-39
- Operating Precautions ..... E-40

Company and product names used in this manual may be registered trademarks of others.

# General Guide

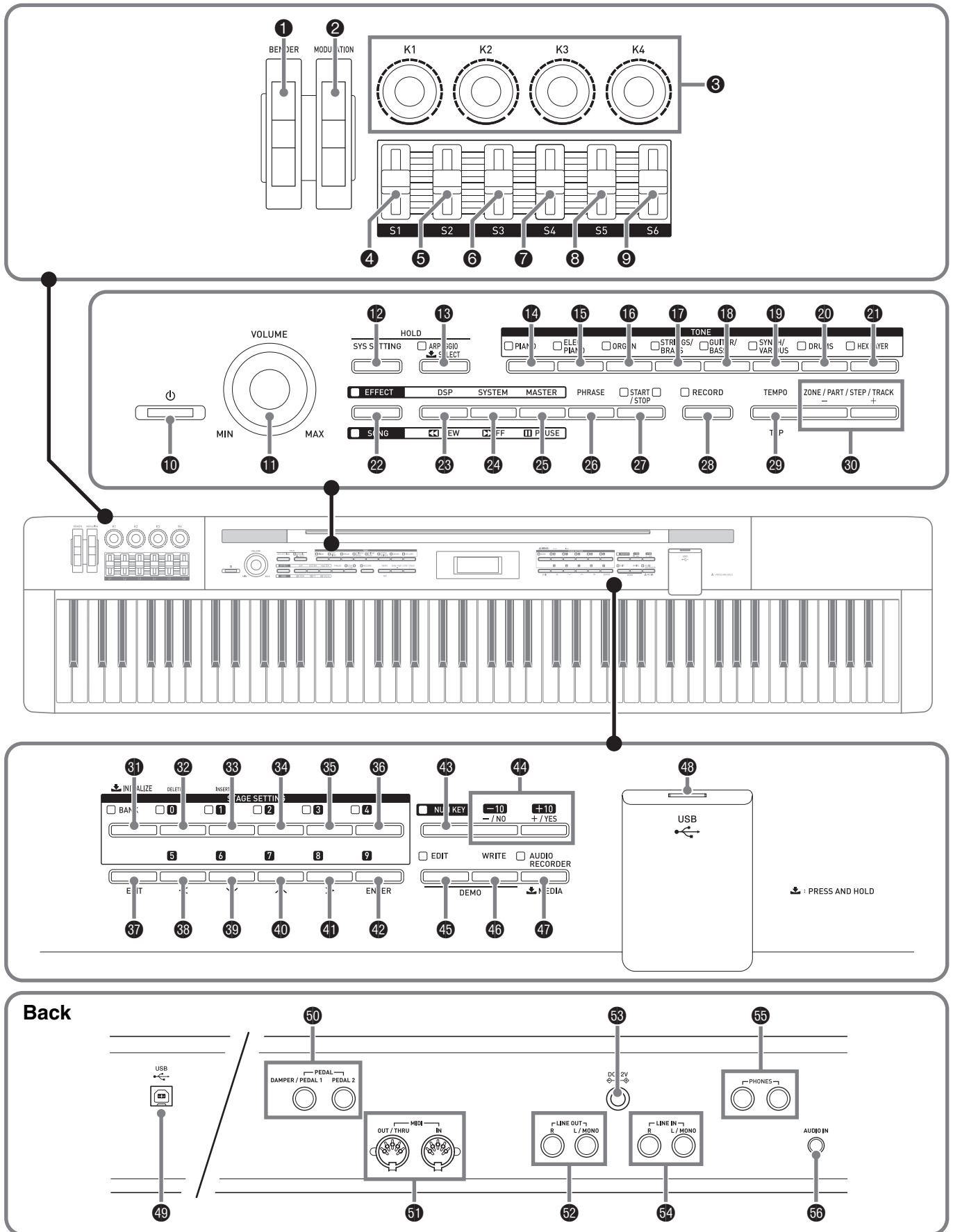

- This manual uses the numbers and names below to refer to buttons and controllers.

- ❶ **BENDER** wheel
- ❷ **MODULATION** wheel
- ❸ **K1** through **K4** knobs
- ❹ **S1** slider
- ❺ **S2** slider
- ❻ **S3** slider
- ❼ **S4** slider
- ❽ **S5** slider
- ❾ **S6** slider
- ❿ ⏻ (**POWER**) button
- ⓫ **VOLUME** controller
- ⓬ **SYS SETTING** button
- ⓭ **ARPEGGIO** button
- ⓮ **PIANO** button
- ⓯ **ELEC PIANO** button
- ⓰ **ORGAN** button
- ⓱ **STRINGS/BRASS** button
- ⓲ **GUITAR/BASS** button
- ⓳ **SYNTH/VARIOUS** button
- ⓴ **DRUMS** button
- ⓵ **HEX LAYER** button
- ⓶ **EFFECT, SONG** button
- ⓷ **DSP, REW** button
- ⓸ **SYSTEM, FF** button
- ⓹ **MASTER, PAUSE** button
- ⓺ **PHRASE** button
- ⓻ **START/STOP** button
- ⓼ **RECORD** button
- ⓽ **TEMPO, TAP** button
- ⓿ **ZONE/PART/STEP/TRACK, -/+** buttons
- Display
- ❶❶ **BANK, INITIALIZE** button
- ❶❷ **0, DELETE** button
- ❶❸ **1, INSERT** button
- ❶❹ **2** button
- ❶❺ **3** button
- ❶❻ **4** button
- ❶❼ **EXIT** button
- ❶❽ **5, <** button
- ❶❾ **6, ∨** button
- ❶❿ **7, ^** button
- ❷❶ **8, >** button
- ❷❷ **9, ENTER** button
- ❷❸ **NUM KEY** button
- ❷❹ **-/NO, +/YES** buttons
- ❷❺ **EDIT** button
- ❷❻ **WRITE** button
- ❷❼ **AUDIO RECORDER, MEDIA** button
- ❷❽ **USB** flash drive port
- ❷❾ **USB** port
- ❷❿ **DAMPER/PEDAL1, PEDAL2** jacks
- ❸❶ **MIDI OUT/THRU, IN** terminals
- ❸❷ **LINE OUT R, L/MONO** jacks
- ❸❸ **DC 12V** terminal
- ❸❹ **LINE IN R, L/MONO** jacks
- ❸❺ **PHONES** jacks
- ❸❻ **AUDIO IN** jack

## Saving Settings and Using Panel Lock

Your Digital Piano lets you save its current settings, and lock its buttons to protect against operation errors. For details, see “Auto Resume” (page E-27) and “Panel Lock” (page E-27).

## Returning the Digital Piano to Its Factory Default Settings

Perform either of the following two procedures when you want to return the Digital Piano’s stored data and settings to their initial factory defaults.

### ■ Method 1

1. Hold down the **10** (⏻) button to turn off the Digital Piano.
  - For details, see “Turning Power On or Off” (page E-6).
2. While holding down the **36** (4) button and **43** (NUM KEY), press the **10** (⏻) button. Keep the **36** (4) and **43** (NUM KEY) buttons depressed until the message “INITIALIZING” appears on the display.
 

After initialization is complete, display contents return to normal.

### ■ Method 2

1. Press the **12** (SYS SETTING) button.
2. Use the **39** (∨) and **40** (∧) buttons to select “Initialize”.
3. Use the **38** (<), **39** (∨), **40** (∧), and **41** (>) buttons to select “Initialize All”.
4. Press the **42** (ENTER) button.
 

This will display a confirmation message “SURE?”.

  - If you want to cancel the initialization, press the **44** (NO) or **37** (EXIT) button.
5. Press the **44** (YES) button to initialize.
 

The message “Please Wait” will remain on the display while the operation is being performed. Do not perform any operation while this message is on the display. “Complete” appears on the display after initialization is complete.

## Separate Tutorial Manual

You can download a separate tutorial manual from the CASIO website below.

<http://world.casio.com/>

# Power Outlet

Your Digital Piano runs on standard household power. Be sure to turn off power whenever you are not using the Digital Piano.

## Using an AC Adaptor

Use only the AC adaptor (JEITA Standard, with unified polarity plug) that comes with this Digital Piano. Use of a different type of AC adaptor can cause malfunction of the Digital Piano.

**Specified AC Adaptor: AD-A12150LW**

- Use the supplied power cord to connect the AC adaptor as shown in the illustration below.

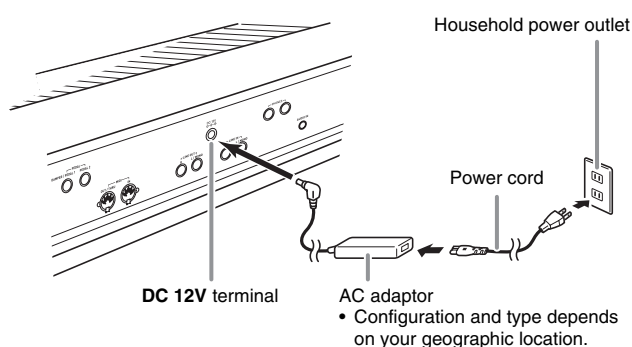

**Note the following important precautions to avoid damage to the power cord.**

### ■ During Use

- Never pull on the cord with excessive force.
- Never repeatedly pull on the cord.
- Never twist the cord at the base of the plug or connector.

### ■ During Movement

- Before moving the Digital Piano, be sure to unplug the AC adaptor from the power outlet.

### ■ During Storage

- Loop and bundle the power cord, but never wind it around the AC adaptor.



### IMPORTANT!

- Never connect the AC adaptor (JEITA Standard, with unified polarity plug) that comes with this Digital Piano to any other device besides this Digital Piano. Doing so creates the risk of malfunction.
- Make sure the Digital Piano is turned off before plugging in or unplugging the AC adaptor.
- The AC adaptor will become warm to the touch after very long use. This is normal and does not indicate malfunction.

## Using Batteries

You can use eight AA-size batteries for power.

- Use alkaline batteries.  
Never use oxyride or any other nickel based batteries.

**1.** On the back of the Digital Piano on the right, loosen the two screws that secure the battery cover in place.

- The screws are designed so they can be loosened only, and not come completely out.

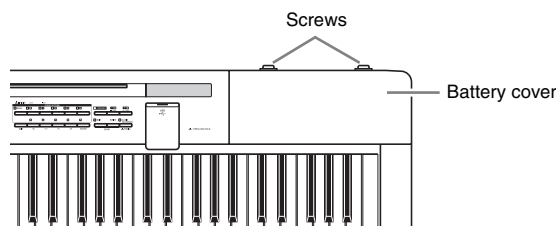

**2.** Slide the battery cover away from you to remove it.

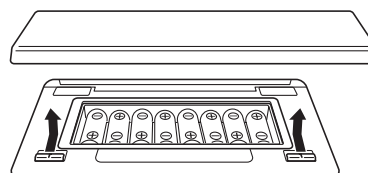

**3.** Load eight AA-size batteries into the battery compartment.

- Make sure the positive  $\oplus$  and negative  $\ominus$  ends of the batteries are facing as shown in the illustration.

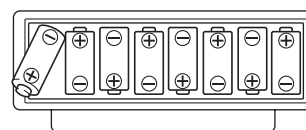

**4.** Replace the battery cover and slide it towards you (the reverse of what you did in step 2) to close it.

- Make sure that the tabs of the battery cover engage with the tabs of the Digital Piano.

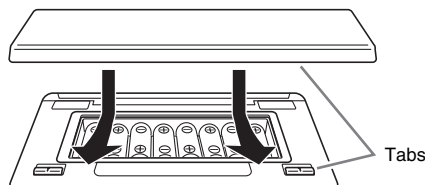

**5.** Secure the battery cover by tightening the two screws you loosened in step 1.

## ■ Low Battery Indication

The following shows the approximate battery life.  
**Approximately 3 hours\*** (alkaline batteries, using the optional CASIO CP-16 headphones)

- \* Using a high volume setting, playing in very low temperatures, and certain other playing conditions can shorten battery life.

Low battery power is indicated by the **22 (EFFECT)** button lamp flashing. Replace the batteries with new ones.



## Turning Power On or Off

1. Press the **10 (P)** button to turn on Digital Piano power.

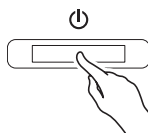

- Use the Digital Piano's **VOLUME** controller (**11**) to adjust the volume.

2. To turn off the Digital Piano, hold down the **10 (P)** button until the Digital Piano's display goes blank.

### NOTE

- Pressing the **10 (P)** button to turn off power actually puts the Digital Piano into a standby state. Minute amounts of current continue to flow within the Digital Piano in the standby state. If you do not plan to use the Digital Piano for a long time or if there is a lightning storm in your area, be sure to unplug the AC adaptor from the power outlet.

## Auto Power Off

The Digital Piano turns off automatically to avoid wasting power if no operation is performed for a preset amount of time. The Auto Power Off trigger time is about six minutes under battery power and about four hours under AC adaptor power.

- You can disable Auto Power Off by turning off the "Auto Power Off" setting as described under "System Settings" (page E-27).



# Connections

## Connecting Headphones

### IMPORTANT!

- Before connecting headphones, be sure to use the Digital Piano's **VOLUME** controller to turn the volume down to a low level. After connecting, you can adjust the volume to the level you want.

### Back

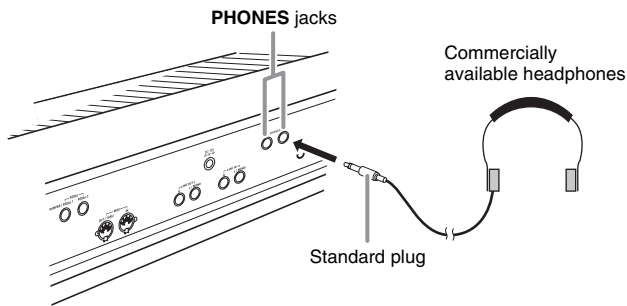

Connect commercially available headphones to the **PHONES** jacks. To protect your hearing, make sure that you do not set the volume level too high when using headphones.

### NOTE

- Be sure to push the headphones plug into the **PHONES** jacks as far as it will go. If you don't, you may hear sound from only one side of the headphones.
- If the plug of the headphones you are using does not match the **PHONES** jacks, use the applicable commercially available adaptor plug.

## Connecting a Pedal

Your Digital Piano has two pedal terminals.

A variety of different functions can be assigned to a pedal.

- Under initial factory settings, the damper pedal\* function is assigned to **DAMPER/PEDAL1**.
  - \* Pressing the damper pedal while playing causes notes you play on the keyboard to be sustained longer.
- Whenever a piano tone is selected, pressing this pedal will activate the Digital Piano's Damper Resonance effect, which causes notes to resonate in the same way they do when the damper pedal on an acoustic piano is pressed.
- For details, see the separate "Tutorial".

### To connect to the pedal jack

Depending on the type of operation you want the pedal (SP-3) to perform, connect the pedal's cable either to the Digital Piano's **DAMPER/PEDAL1** jack or **PEDAL2** jack. If you want to use both operations (jacks) at the same time, you need to purchase another optionally available pedal.

### Back

**DAMPER/PEDAL1, PEDAL2** jacks

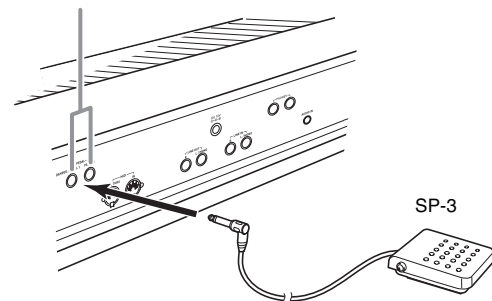

## Connecting Audio Equipment or an Amplifier

This Digital Piano outputs notes from its **LINE OUT R** (right channel output) and **LINE OUT L/MONO** (left channel output). Connect a keyboard amplifier or other device to direct output to speakers. You can adjust the **LINE OUT** volume level with the Digital Piano's **VOLUME** controller.

### IMPORTANT!

- Whenever connecting something to the Digital Piano, first use the **VOLUME** controller to set the volume to a low level. After connecting, you can adjust the volume to the level you want.
- Whenever you connect any device to the Digital Piano, be sure to read the user documentation that comes with the device.

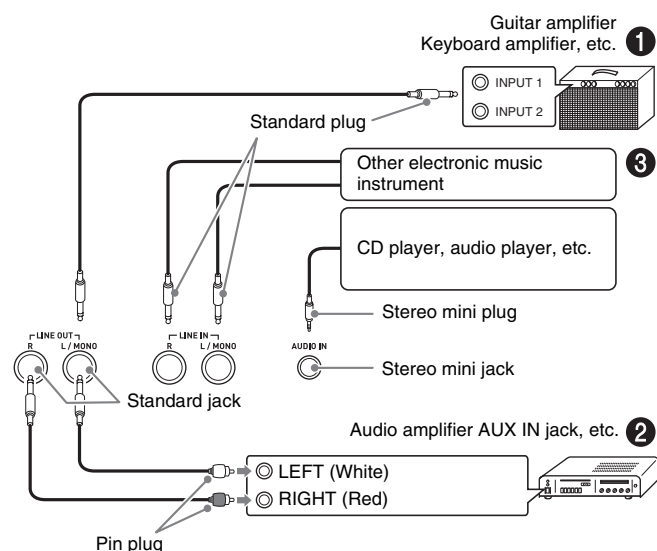

### To output to a musical instrument amplifier (Figure ①)

Use a commercially available connecting cord to connect the amplifier to the Digital Piano's **LINE OUT L/MONO** jack as shown in Figure ①. Connecting a cord to **LINE OUT L/MONO** only will cause the left and right channels to be mixed and output as mono.

### To output to audio equipment (Figure ②)

Use commercially available connection cords to connect as shown in Figure ②. Normally, you should set the input selector of the audio equipment to the terminal where the Digital Piano is connected (AUX IN, etc.)

### To input from audio equipment (Figure ③)

Connect the Digital Piano's **AUDIO IN** terminal to the audio equipment as shown in Figure ③. You can also connect to the **LINE IN R** and **LINE IN L/MONO** terminals. Use commercially available connection cords that match the equipment being connected to.

Connecting a cord to **LINE IN L/MONO** only will cause the left and right channels to be mixed and output from both **LINE OUT R** and **LINE OUT L/MONO**.

## Bundled and Optional Accessories

Use only accessories that are specified for use with this Digital Piano.

Use of unauthorized accessories creates the risk of fire, electric shock, and personal injury.

### NOTE

- You can get information about accessories that are sold separately for this product from the CASIO catalog available from your retailer, and from the CASIO website at the following URL.  
<http://world.casio.com/>

# Operations Common to All Modes

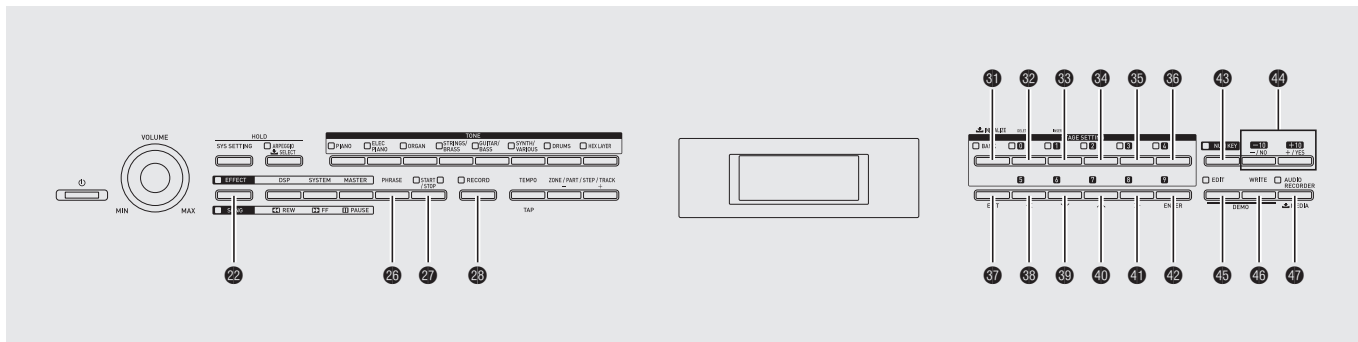

The operations described in this section are common to all modes and functions.

## Changing a Number or a Value

Use the operations in this section to specify a number or to change a value.

*Example:* To change a tone number

After using buttons 14 through 21 (Tone Group) to specify a group, use one of the methods below to change the selected tone number. (For details about selecting tones, see “Using Built-in Tones” on page E-14.)

### To scroll a number sequentially

1. Press the 44 minus (-) or plus (+) button.

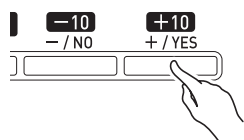

### To fast scroll a number

1. Hold down the 44 minus (-) or plus (+) button.

### To jump in steps of 10

1. While holding down the 43 (NUM KEY), press the 44 minus (-) or plus (+) button.

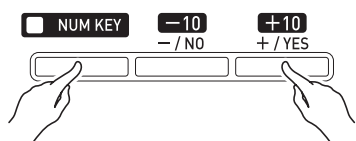

### To input a number with the 10-key pad

1. Press the 43 (NUM KEY) button.  
This will cause the button’s lamp to light, indicating the number input mode.
2. Use buttons 32 (0) through 36 (4) and buttons 38 (5) through 42 (9) to input the number you want.

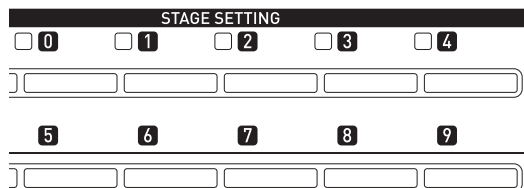

### To return a number to its initial default setting

- The initial default of a number depends on the parameter being set.
1. Press the 44 minus (-) and plus (+) buttons at the same time.

#### NOTE

- You can also input numbers and characters using the Digital Piano’s knobs. For more information, see the separate “Tutorial”.

## Inputting Text Characters

Use the procedures in this section to input or edit names.

*Example:* When creating a new phrase and saving data (For details, see “Recording and Playing Back Phrases” on page E-18.)

If you are saving a newly created phrase in Digital Piano memory, display the Digital Piano’s save menu (“Saving Data”, page E-11) before trying to input characters using the procedure below.

- With this method, you select one of the characters shown below.

!	"	#	\$	%	&	'	(	)	
*	+	,	-	.	/	0	1	2	3
4	5	6	7	8	9	:	;	<	=
>	?	@	A	B	C	D	E	F	G
H	I	J	K	L	M	N	O	P	Q
R	S	T	U	V	W	X	Y	Z	[
\	]	^	_	`	a	b	c	d	e
f	g	h	i	j	k	l	m	n	o
p	q	r	s	t	u	v	w	x	y
z	{		}	~					

- For information about characters that are supported when using a USB flash drive, see “Renaming a USB Flash Drive File” (page E-33).

1. Use the 38 (<), 39 (∨), 40 (^), and 41 (>) buttons to move the cursor to location where you want to input the character.

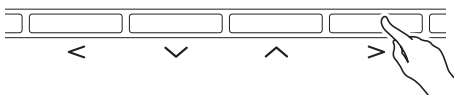

2. You can use either of the methods below to select a character and input it.

• **Method 1**

Press the 44 minus (-) or plus (+) button to scroll sequentially through characters and symbols. With this method, each time you press the 44 minus (-) or plus (+) buttons at the same time, input jumps to the first character of a group in the following sequence: Symbols → Numerals → Upper case → Lower case.

• **Method 2**

Press the 43 (NUM KEY) button so its lamp becomes lit.

Next, use the 12 buttons from 31 to 42 to input letters as shown in the illustration below. Each press of a button cycles through the letters assigned to it at the current cursor location.

After inputting the letters you want, press the 43 (NUM KEY) button so its lamp becomes unlit.

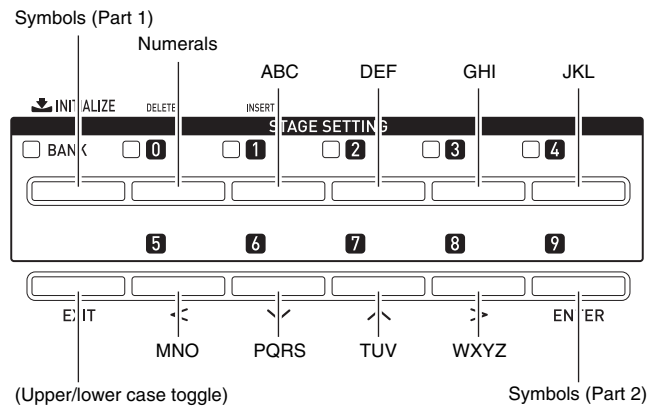

**NOTE**

- You can also input numbers and characters using the Digital Piano’s knobs. For more information, see the separate “Tutorial”.

## Saving Data

Use the procedure below to save edited and registered data to Digital Piano memory.

1. Press the **46 (WRITE)** button.



2. If the data lets you change its number or data name, perform the procedure under “Inputting Text Characters” on page E-10.

- You can also input numbers with the 10-key pad. For details, see “To input a number with the 10-key pad” in “Operations Common to All Modes” (page E-9).
- To specify a number, move the cursor to the location where the number is located.
- To specify a name, move the cursor to the first character of the location where the name is located.

3. Press the **42 (ENTER)** button.

This will display a confirmation message “SURE?”.



- If you want to cancel the save operation, press the **44 (NO)** or **37 (EXIT)** button.

4. Press the **44 (YES)** button.

The message “Please Wait” will remain on the display while the operation is being performed. Do not perform any operation while this message is on the display. “Complete” appears on the display after data save is complete.

- If there is already data at the location you are saving the new data or if there is already a file with the same name you specified, a message “Replace?” will appear asking if you want to overwrite the existing data with the new data. Press the **44 (YES)** button to overwrite or the **(NO)** button to cancel the save operation.

## Starting and Stopping Playback

Use the procedure below with functions that allow playback of data.

1. Press the button of the function you want to use the required number of times until the button lamp is lit.

The button of each function has a lamp. When the lamp of a function button is lit, it means the function is standing by for playback.

- **22 (SONG)** button: Song sequencer playback (page E-21)
- **26 (PHRASE)** button: Phrase sequencer playback (page E-18)
- **47 (AUDIO RECORDER)** button: Audio recorder playback (page E-23)

2. Press the **27 (START/STOP)** button to start playback.

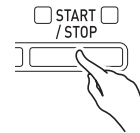

3. Press the **27 (START/STOP)** button to stop playback.

## Starting and Stopping Recording

Perform the procedure below with functions that allow recording of data (phrase sequencer and audio recorder).

1. In step 1 under “Starting and Stopping Playback”, press the button of the function you want to use the required number of times until the button lamp is flashing.

This will enter the recording standby state, which is indicated by the 26 (RECORD) button also flashing.



2. Now, any one of the following will start recording.

- Pressing the 26 (RECORD) button
- A pedal operation
- A knob operation
- A slider operation
- A wheel operation
- Playing something on the keyboard

When recording starts, the 26 (RECORD) button lamp will change from flashing to lit. The lamp of the button of the function you selected will continue flashing.

3. Press the 26 (RECORD) button to stop recording.

This will cause the button's lamp to go out. The function you are using will go into playback standby and the lamp of the function's button will change from flashing to lit. This indicates the same status as that after step 1 is performed under “Starting and Stopping Playback” on page E-11.

### NOTE

- The following describes button lamp operations that are common to the song sequencer, phrase sequencer, and audio recorder functions.

- A) Function button lamps: 22 (SONG) button, 26 (PHRASE) button, 47 (AUDIO RECORDER) button

**Unlit:** Function disabled.

**Flashing:** Recording using the function in standby or in progress.

**Lit:** Playback using the function in standby or in progress.

- B) 26 (RECORD) button lamp

**Unlit:** All recording disabled.

**Flashing:** Recording using the function whose button is flashing in standby.

**Lit:** Recording using the function whose button is flashing in progress.

- The following describes button lamp operations that are common to the song sequencer, phrase sequencer, and audio recorder functions when a button is pressed.

- C) Operation when the 27 (START/STOP) button is pressed.

**When playback is not in progress:** Starts playback of the function whose lamp is lit.

**When playback is in progress:** Stops playback.

- D) Operation (functions that support recording only) when the 26 (RECORD) button is pressed.

**When the 26 (RECORD) button lamp is flashing (recording standby):** Starts recording with the function whose lamp is flashing.

**When the 26 (RECORD) button lamp is lit (recording in progress):** Stops recording. If more than one playback operation is in progress, they are all stopped.

## Using the Editing Function

Use the procedure below with functions that allow editing of tones and data. Editing lets you change the parameters of each editable item.

1. Press the **45 (EDIT)** button.  
This displays the editing screen.
2. Use the **38 (<)**, **39 (∨)**, **40 (^)**, and **41 (>)** buttons to select the item you want to edit.
  - If ">ENT" is on the display, it means that there are more items that can be edited in the operation you are performing. In this case, pressing the **42 (ENTER)** button will advance to the next editing page.
3. Change parameters as desired.
  - For details about how to change parameters, see "Changing a Number or a Value" in "Operations Common to All Modes" (page E-9).
4. After you finish with your edits, use the **37 (EXIT)** button to exit the editing screen.
  - Press the **37 (EXIT)** button the required number of times to navigate back to the screen that was displayed when you started editing.

## Meanings of Symbols Next to Numbers

The meanings of the symbols next to numbers after you record or edit data are explained below.

! : Unsaved data

\* : Saved data

- Unsaved data (!) will be discarded if you exit the editing or recording operation by selecting a different number. Don't forget to save data that you want to retain. See "Saving Data" in "Operations Common to All Modes" (page E-11) for more information.

# Using Built-in Tones

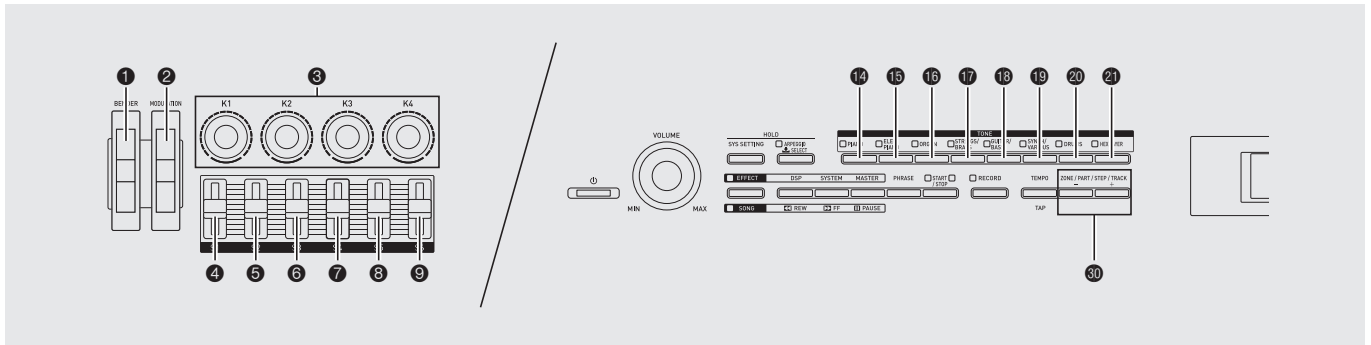

## Selecting a Tone

Your Digital Piano has memory for 720 tones (370 presets and 350 user tones), divided into eight groups.

- For more information about tones (Tone List), see the separate “Tutorial”.
- The Digital Piano has built-in demonstration tunes that highlight the different characteristics of tones. For more information, see “Playing Demo Songs” (page E-16).

1. Use the “Tone List” to look up the group and the number of the tone you want to select.
2. Use the 14 to 21 (tone groups) buttons to select the group you want.

*Example:* To select the ORGAN group

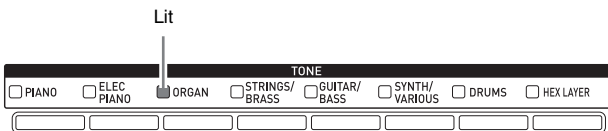

3. Specify the number of the tone you want to use.
  - For details about how to do this, see “Changing a Number or a Value” in “Operations Common to All Modes” (page E-9).

*Example:* To select “01 Organ3 G”

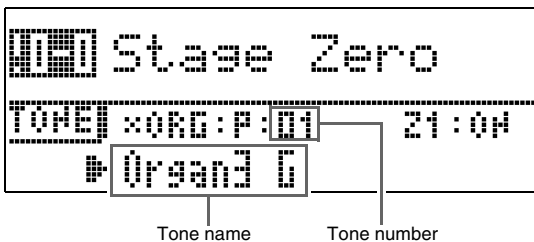

## NOTE

### Zones

- To specify a tone for each zone,\* use the 30 (ZONE, -/+ ) buttons to select a zone number, and then perform steps 1 through 3 above to change select a tone.
- Press the 30 (ZONE, -/+ ) buttons at the same time to toggle the currently selected zone tone between muted and unmuted.

\* For details about zones, see the separate “Tutorial”.

## Editing a Tone

You can use the procedure below to edit a tone to suit your needs. You can also use the editing menu to specify DSP and system effects.

1. Specify the number of the tone you want to edit.
  - For details about how to do this, see “Selecting a Tone” on page E-14.
2. Edit the tone as desired.
  - For details about how to do this, see “Using the Editing Function” in “Operations Common to All Modes” (page E-13).



- The items that appear on the editing screen depend on the tone you select.
- For details and actual parameters, see the separate “Tutorial”.



## Using the Bender Wheel

You can use the bender wheel to slide the pitch of notes smoothly upwards and downwards. This capability makes it possible to reproduce saxophone and electric guitar choking effects.

### Adding a Pitch Bend Effect

1. While playing a note on the keyboard, rotate the **① (BENDER)** wheel on the left of the keyboard upwards or downwards.

The amount the note bends depends on how much you rotate the pitch bend wheel.

- Do not have the pitch bend wheel rotated as you turn on the Digital Piano.

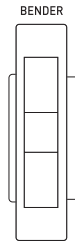

#### NOTE

- You also can configure pitch bend wheel operation by specifying the amount of pitch change at maximum rotation in either direction. For more information, see the separate "Tutorial".

## Modifying Notes with the Modulation Wheel, Knobs and Sliders

You can modify notes even while you are playing. Each tone is preset with effects that are appropriate for it.

1. While playing on the keyboard with your right hand, you can operate the **② (MODULATION)** wheel, **③ (K1 through K4)**, and sliders **④ (S1) through ⑨ (S6)**.

The amount effect applied depends on how much the applicable control is moved.

- Do not have the modulation wheel, knobs, or sliders in a moved position as you turn on the Digital Piano.

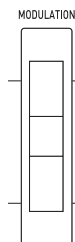

#### NOTE

- You can change the effects and functions assigned to the modulation wheel, knobs, and sliders. For more information, see the separate "Tutorial".
- For information about other functions related to "Using Built-in Tones", see the separate "Tutorial".

# Playing Demo Songs

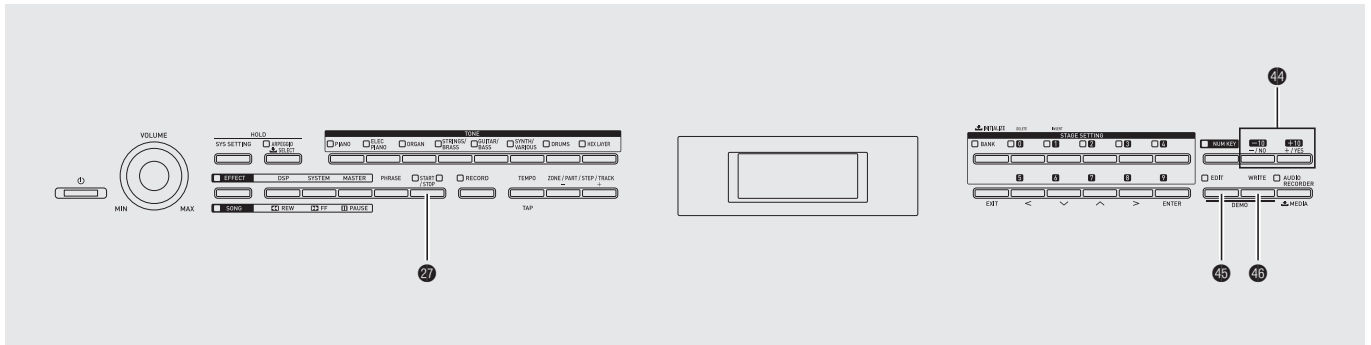

1. While holding down the **45 (EDIT)** button, press the **46 (WRITE)** button.  
This will start sequential playback of the demo songs, starting from song 1.

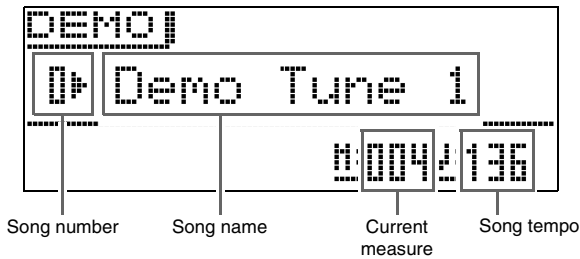
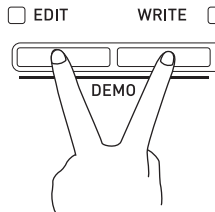

- You can scroll through songs manually with the **44 (-, +)** buttons.

2. Press the **27 (START/STOP)** button.  
This stops demo song playback.  
Playback of the demo songs will continue in an endless loop until you press the **27 (START/STOP)** button to stop it.

## NOTE

- Only the operations described above can be performed while demo song playback is in progress.

# Sounding Arpeggios Automatically

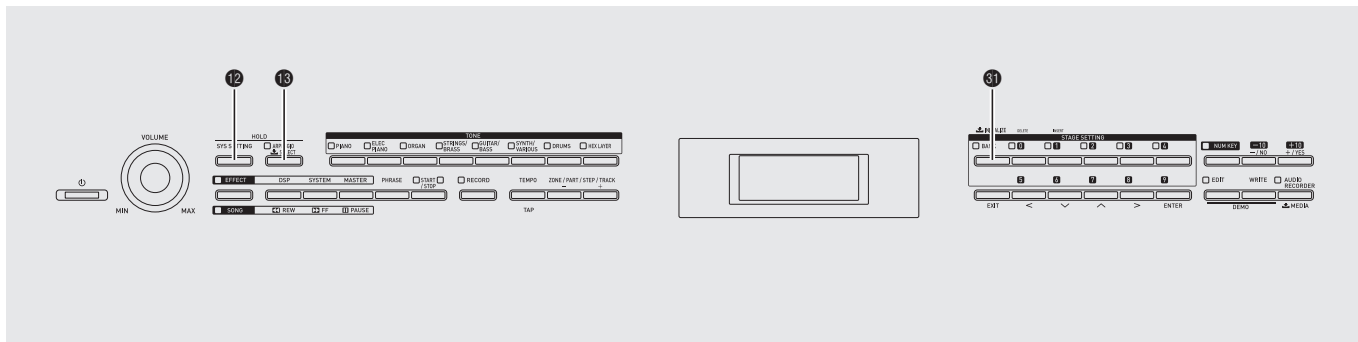

With the Arpeggio Function, you can play various arpeggios automatically by simply pressing keys on the keyboard. You can select from a number of different arpeggio types for playback, including arpeggios using the notes that make up a chord you play on the keyboard, arpeggios that also include notes that are automatically inserted in addition to those that make up a chord you play on the keyboard, and more.

- The Arpeggio Function has 100 arpeggio type presets (Arpeggio number 000 to 099). An arpeggio type preset can be edited and saved as a user arpeggio type. There is memory for up to 100 user arpeggio types (Arpeggio number 100 to 199).
- A HOLD function is provided to enable arpeggios to continue to play even after keyboard keys are released.

## To use the Arpeggio Function

1. Hold down the **13 (ARPEGGIO)** button until the arpeggio type selection screen shown below appears on the display.

This will cause the button's lamp to light.

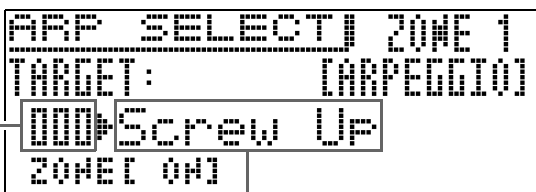

2. Specify the arpeggio number you want.

- For details about how to do this, see “Changing a Number or a Value” in “Operations Common to All Modes” (page E-9).

3. Turn arpeggio hold on or off.

- While holding down the **12 (SYS SETTING)** button, press the **13 (ARPEGGIO)** button to toggle HOLD between on and off.

OFF : The arpeggio will play while keyboard keys are depressed.

ON : The arpeggio will continue to play even after the keyboard keys are released.

- The **13 (ARPEGGIO)** button lamp flashes while arpeggio hold (HOLD) is turned on.

4. Press some keys and the arpeggio will start to play automatically.

- Press the **13 (ARPEGGIO)** button to toggle arpeggio between on and off.
- To stop arpeggio HOLD playback, press **13 (ARPEGGIO)** button or change the HOLD function in step 3 of the above procedure to OFF.

## Using the Arpeggio Type Selection Screen to Select the Recommended Tone as the Zone Part Tone

- For details about zone parts, see the separate “Tutorial”.

1. Hold down the **13 (ARPEGGIO)** button until the arpeggio type selection screen appears on the display.
2. Hold down the **31 (BANK)** button until its lamp starts to flash.

### NOTE

- In the case of a user arpeggio, the tone that was selected as the Zone Part tone when the user data was saved is the recommended tone.

- For information about other functions related to “Sounding Arpeggios Automatically”, see the separate “Tutorial”.

# Recording and Playing Back Phrases

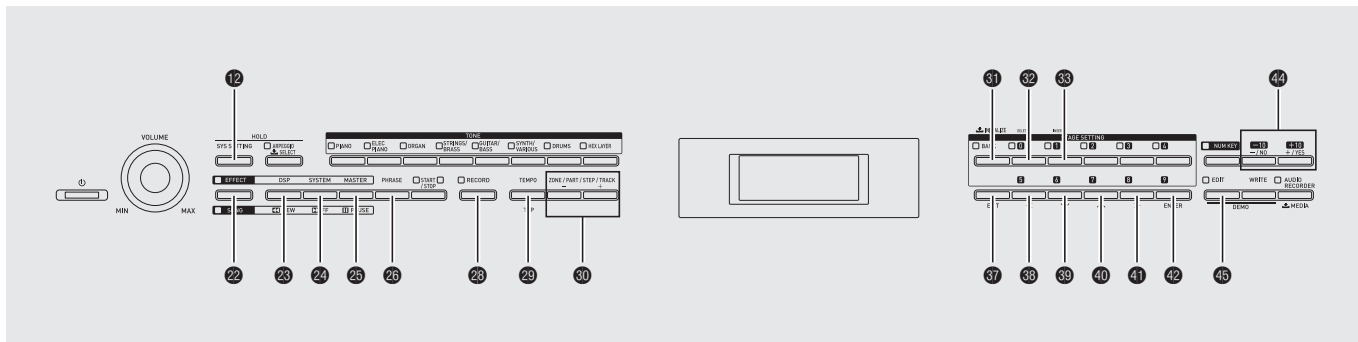

The Phrase Sequencer is a great way to record musical phrases that suddenly pop into your mind for later playback.

- You can record a new phrase or overdub onto an existing phrase to create a user phrase. There is memory for storage of up to 1,000 user phrases (phrase number 000 to 999) for later recall when you need them.
- In addition to what you play on the keyboard, your pedal, wheel, knob, and slider operations are also recorded as part of phrase. Note, however, that pedal, modulation wheel, knob, and/or slider operations may not be recorded when certain functions are assigned to pedals, knobs, and/or sliders. For more information, see the separate “Tutorial”.
- You can choose either of two different playback options: one-time playback (loop off) or repeat playback (loop on).
- Overdubbing during looped playback is supported.
- A Song Sequencer function lets you combine phrase data into song data. With this Digital Piano, song data is referred to as a “song”. For details, see “Creating a Song (Song Sequencer)” (page E-21).

## Recording a New Phrase

- You can record up to approximately 1,600 notes for a single phrase. Also, recorded wheel, knob, and slider operations significantly reduce the remaining number of notes available for recording.
- Note that you cannot record a phrase while an Audio Recorder (page E-23) operation is in progress.

1. Press the **26 (PHRASE)** button the required number of times until its lamp starts to flash.



- If OVDB (overdubbing) is displayed as the “Rec Mode” setting, use the **44** minus (-) and plus (+) buttons to change it to NEW (new phrase). This will enter the new phrase recording standby mode.
- Note quantize and end measure settings can be configured as required.

### ■ Note Quantize (Note Qntz)

When recording keyboard play, there may be cases when your timing strays a bit. The note quantize settings described below can be used to correct the timing of keyboard play automatically and correct the timing of notes you play on the keyboard. (Note that only key press timing is correct. The timing of other operations such as key release, and wheel, pedal, knob, and slider operations are not corrected.)

- Off : Timing not adjusted. (Notes are recorded as played.)
- ♪, ♪, ♫ : Timing of actual keyboard play is corrected to the nearest note in accordance with the specified note unit.

## ■ Configuring End Measure Settings

End Measure settings specify the number of measures (up to a maximum of 16) in the phrase. Phrase recording stops automatically when it reaches the number of measures specified by the End Measure setting.

- Auto : No number of measures is specified. The number of measures where phrase recording was stopped is applied automatically.
- 1 to 16 : Phrase recording stops when it reaches the specified number of measures.

- Pressing the **12** (SYS SETTING) button will display a menu of the detailed settings shown below. Use the **39** down (▼) and **40** up (▲) buttons to select a parameter and then use the **44** minus (-) and plus (+) buttons to change its setting.

Menu	Description	Setting Range
Guide Beat	Guide tone (Guide Beat). Specifies whether or not a count tone is sounded during phrase recording and/or record standby.	Off, On
Precount	Precount (Precount). Specifies the number of measures of count.	Off 1:1 measure, 2:2 measures
HighReso/ Off Velo	High-resolution sound source (High Reso Velocity) and off velocity (Off Velocity). Turning on this setting records with both a high-resolution sound source and Off velocity. However, the maximum number of measures that can be recorded is halved when this option is turned on.	Off, On

- Pressing the **45** (EDIT) button will display a screen for configuring Guide Beat (click), precount, and End Measure beat settings. Use the **39** (▼) and **40** (▲) buttons to select "Beat", and then use the **44** minus (-) and plus (+) buttons to select a beat within the ranges of 2/4 to 8/4, or 2/8 to 16/8.



## 2. Start recording.

- For details about how to do this, see "Starting and Stopping Recording" in "Operations Common to All Modes" (page E-12).
- Recording is performed as a Zone 1 stage setup phrase. For details about zones, see the separate "Tutorial".

## 3. After you finish recording, save the data as described below.

- For details about how to do this, see "Saving Data" in "Operations Common to All Modes" (page E-11).
- The message "Memory Full" will appear on the display when recording is not possible because there is not enough memory capacity available. If this happens, record a different phrase that does not take up so much memory.
- For information about deleting data you saved, see page E-28.

## ■ Saving a Phrase to an External Device

- USB flash drive (page E-32)
- Computer (page E-37)

## Listening to a Phrase

### 1. Press the **26 (PHRASE)** button.

This displays the phrase selection screen shown below.

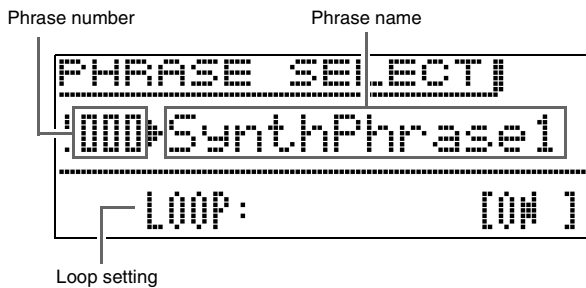

### 2. Specify the number of the phrase you want to hear.

- For details about how to do this, see “Changing a Number or a Value” in “Operations Common to All Modes” (page E-9).

### 3. Use the **39 (✓)** button to select “Loop”, and then use the **44 (-)** and plus **(+)** buttons to turn looping on or off.

OFF : One-time playback

ON : Looped playback

### 4. Play the phrase.

- For details about how to do this, see “Starting and Stopping Playback” in “Operations Common to All Modes” (page E-11).
- The phrase loop setting is saved as a parameter for each phrase.

## Changing the tempo setting

There are two different methods you can use to change the tempo setting: using the **TEMPO** buttons or tapping a beat with a button.

- You can use this procedure to adjust the tempo not only for phrases, but also for other functions as well.

### ■ To change the tempo using the **TEMPO** buttons

#### 1. Press the **29 (TEMPO)** button.

- This displays the tempo screen shown below.

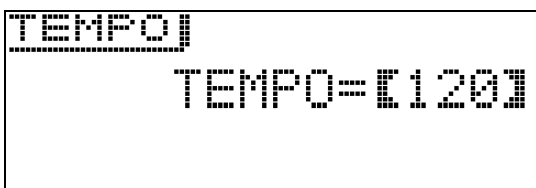

#### 2. Adjust the tempo (beats per minute) value as desired.

- For details about how to do this, see “Changing a Number or a Value” in “Operations Common to All Modes” (page E-9).
- You can also change the tempo value using the **30 (-)** and plus **(+)** buttons.
- You can specify a tempo value in the range of 020 to 255.

#### 3. Press the **37 (EXIT)** button.

This exits the tempo screen.

### ■ To adjust the tempo by tapping a beat

#### 1. Press the **29 (TEMPO)** button.

This displays the tempo screen.

#### 2. Tap the **29 (TAP)** button four times at the speed (tempo) you want to set.

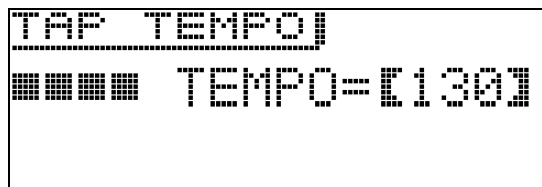

- The tempo setting will change in accordance with your tapping speed as soon as you tap the fourth time.

#### 3. After setting the tempo by tapping, you then can use the procedure under “To change the tempo using the **TEMPO** buttons” (page E-20) to make fine adjustments.

## Using the Phrase Selection Screen to Select the Recommended Tone as the Zone Part 1 Tone

- For details about zone parts, see the separate “Tutorial”.

#### 1. Press the **26 (PHRASE)** button to display the “PHRASE SELECT” screen (page E-20) for selecting a phrase.

#### 2. Hold down the **31 (BANK)** button until its lamp starts to flash.

The tone that was selected as the Zone Part 1 tone when the data was saved is the recommended tone.

## Recording Over Another Phrase (Overdubbing)

1. Select the phrase you want to overdub.
2. Press the **26 (PHRASE)** button the required number of times until its lamp starts to flash.
  - If NEW (new phrase) is displayed as the “Rec Mode” setting, use the **44** minus (-) and plus (+) buttons to change it to OVDB (overdubbing). This will enter the overdubbing standby mode.
3. Start recording.
  - For details about how to do this, see “Starting and Stopping Recording” in “Operations Common to All Modes” (page E-12).
  - The original phrase will playback as a loop. Anything you play on the keyboard and any operations you perform during loop playback will be overdubbed onto the original phrase.

### ■ To delete the last recorded data (undo)

While phrase playback is in progress or stopped, or while overdubbing is in progress, hold down the **28 (RECORD)** button until the undo screen “PHRASE : UNDO” appears.

- You can also use the operation below to perform an undo operation while the PHRASE SELECT screen shown under “Listening to a Phrase” (page E-20) is displayed. Press the **45 (EDIT)** button and then use the **39 (✓)** and **40 (∧)** buttons to select “Undo”. Finally, press the **42 (ENTER)** button. This will display an undo screen. Perform the procedure from step 3 under “Saving Data” on page E-11 of the “Operations Common to All Modes” section.
- The message “PHRASE : Can’t UNDO” will be appear on the display if you try to perform an undo operation again after already undoing the last recording. Press the **37 (EXIT)** button to clear the message.

## To save a phrase

For details about how to save data, see “Saving Data” in “Operations Common to All Modes” (page E-11).

- If there is not enough Digital Piano memory space available to store the phrase data, the message “not enough space” will appear on the above display in place of “Press Enter”, and you will not be able to save the phrase data. If this happens, delete some of the data in the Digital Piano’s memory to free up memory space.
- For information about deleting data you saved, see page E-28.
- The Digital Piano can store up to 1,000 user phrases of a combined data volume of 1MB.

### ■ Saving a Phrase to an External Device

- USB flash drive (page E-32)
- Computer (page E-37)

## Creating a Song (Song Sequencer)

The Song Sequencer lets you combine phrase data into song data. With this Digital Piano, song data is referred as a “song”.

### To create a song

1. Press the **22 (SONG)** button so the “SONG” side lamp becomes lit.



2. Specify the song number you want.
  - For details about how to do this, see “Changing a Number or a Value” in “Operations Common to All Modes” (page E-9).
3. Press the **45 (EDIT)** button.

**4.** Use the **39** (∨) and **40** (∧) buttons to select a song edit item and then press the **42** (ENTER) button.

- If you want to create a new song, select “TRACK EDIT”. See step 5 of this procedure for information about how to create a song.
- To adjust the song tempo value, select “Tempo”. For details about how to change this setting, see “Changing a Number or a Value” in “Operations Common to All Modes” (page E-9).
- For information about using “Song Mixer”, see the separate “Tutorial”.

**5.** Edit the song as required.

- Use the **30** minus (–) and plus (+) buttons to select a track.
- To change the phrase number and other settings, use the **38** (<), **39** (∨), **40** (∧), and **41** (>) buttons to move the underscore ( ) to a setting to select it, and then use the **44** minus (–) and plus (+) buttons to change the selected setting.

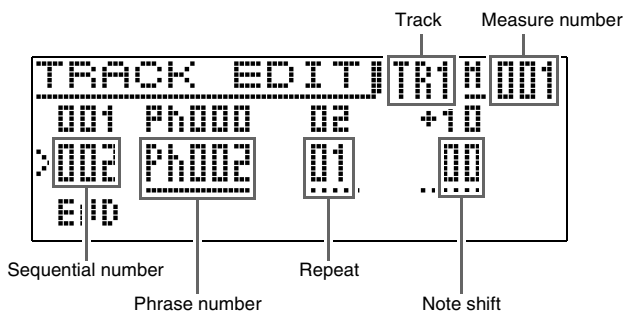

Menu	Description	Settings
Phrase number	Number of the phrase to be used	Ph000 to Ph999
Repeat	Number of times play of the phrase is repeated	1 to 99
Note shift	How much notes in the phrase should be shifted	-24 to +24

- To delete part of a phrase, press the **32** (DELETE) button.
- To insert part of a phrase, press the **33** (INSERT) button.
- The maximum number of tracks is eight.
- The maximum sequential number value is 999.
- Song editing cannot be performed while song playback is in progress.

**6.** After you are finished editing a song, save it.

- For details about how to save data, see “Saving Data” in “Operations Common to All Modes” (page E-11).
- For information about deleting data you saved, see page E-28.

**■ Saving Songs to an External Device**

- USB flash drive (page E-32)
- Computer (page E-37)

**To play back a song**

**1.** Press the **22** (SONG) button so the “SONG” side lamp becomes lit.



**2.** Specify the song number you want.

- For details about how to change this setting, see “Changing a Number or a Value” in “Operations Common to All Modes” (page E-9).

**3.** Start playback.

- For details about how to do this, see “Starting and Stopping Playback” in “Operations Common to All Modes” (page E-11).
- Use the **23** (REW) button to scroll back measure-by-measure, or the **24** (FF) button to scroll forward.
- You can pause playback by pressing the **25** (PAUSE) button.
- You can edit a song later, if you want. For information about how to do this, see “To create a song” on page E-21.

- For information about other functions related to “Recording and Playing Back Phrases”, see the separate “Tutorial”.



# Recording Your Keyboard Play

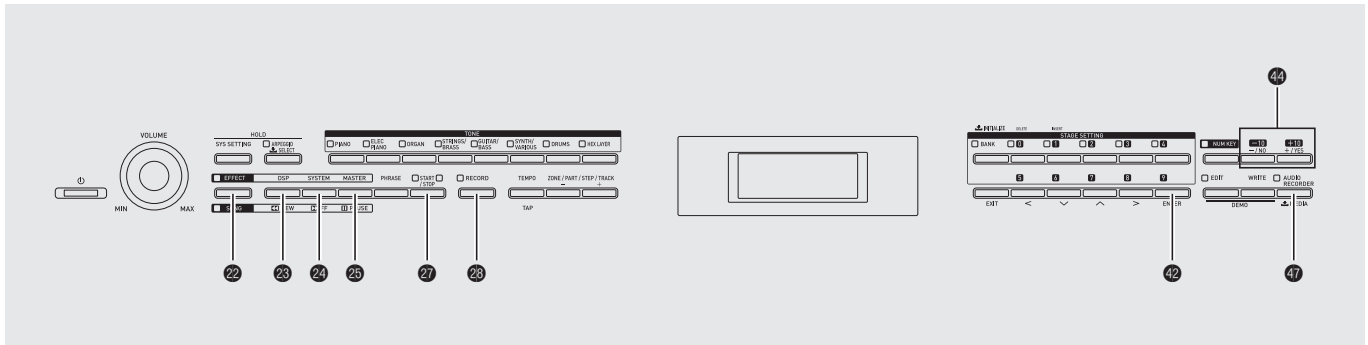

When a commercially available USB flash drive is inserted in the Digital Piano's USB flash drive port, audio data can be recorded to and played back from the USB flash drive (Audio Recorder).

## Recording to a USB Flash Drive

Anything played on the Digital Piano is recorded to the USB flash drive as audio data (WAV files\*). If you play along on the Digital Piano as you play back data stored in the song and phrase sequencer, the memory playback and your keyboard play are both recorded to USB flash drive.

\* Linear PCM, 16bit, 44.1 kHz, Stereo

### Recording Capacity

- 100 files (No. 00 to No. 99)
- Approximately 25 minutes maximum recording per file

### Recorded Data

- Anything played on the Digital Piano is recorded.
- Individual part recording is not supported.

### Recording Data Storage

Each new recording of audio data to a USB flash drive is automatically assigned a new file name, so existing data is not overwritten.

## Recording Digital Piano Play

### PREPARATION

- Be sure to format the USB flash drive on the Digital Piano before using it. See "USB Flash Drive" on page E-29 for more information.

### 1. Insert the USB flash drive into the Digital Piano's USB flash drive port.

- When you plug in a USB flash drive, the Digital Piano initially needs to "mount" the USB flash drive and prepare for data exchange. Note that Digital Piano operations are momentarily disabled while a USB flash drive mounting sequence is being performed. While the mounting process is in progress, the message "Mounting Media" will be displayed on the display. It may take up to 10 or 20 seconds or even longer for a USB flash drive to be mounted. Do not attempt to perform any operation on the Digital Piano while a mounting sequence is in progress. A USB flash drive needs to be mounted each time it is connected to the Digital Piano.
- If you turn on the Digital Piano while USB flash drive is plugged into the Digital Piano, the mount operation described above will need to be performed, and Digital Piano operation will be disabled during that time.

### 2. Press the **47 (AUDIO RECORDER)** button the required number of times until the button lamp starts to flash.

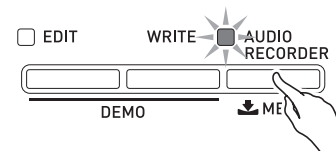

### 3. Start recording.

- For details about how to do this, see “Starting and Stopping Recording” in “Operations Common to All Modes” (page E-12).
- This will start recording to the USB flash drive. The message “Audio Recording . . .” will appear on the display.

#### NOTE

- Do not remove the USB flash drive from the USB flash drive port while the **AUDIO RECORDER** button lamp is lit or flashing. Doing so will interrupt recording and may corrupt data.
- To exit the Audio Recorder, press the **47 (AUDIO RECORDER)** button the required number of times until its lamp goes out.

### To record keyboard play while playing back a phrase or song

#### 1. Select the phrase or song you want to play back.

- Phrase: Perform steps 1 through 3 under “Listening to a Phrase” (page E-20).
- Song: Perform steps 1 and 2 under “To play back a song” (page E-22).

#### 2. Press the **47 (AUDIO RECORDER)** button the required number of times until the button lamp starts to flash.

#### 3. Start recording.

- For details about how to do this, see “Starting and Stopping Recording” in “Operations Common to All Modes” (page E-12).
- At the point where you want to start phrase or song playback while recording, press the **47 (START/STOP)** button.
- To turn off playback and continue recording, press the **47 (START/STOP)** button again.

#### 4. To stop recording, press the **28 (RECORD)** button.

- The **28 (RECORD)** button lamp will go out to let you know that audio recording is stopped. Phrase/song playback also will automatically stop at this time.
- To exit the Audio Recorder, press the **47 (AUDIO RECORDER)** button the required number of times until the button lamp goes out.

#### NOTE

- A MIDI file (SMF) cannot be played back during recording.

### To play back performance data recorded on a USB flash drive

#### 1. Press the **47 (AUDIO RECORDER)** button the required number of times until the button lamp is lit.

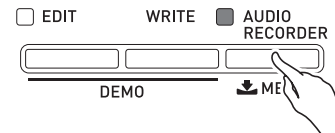

This will display the audio file selection screen.

#### 2. Use the **44 (-, +)** buttons to select a song.

- The **44 (-)** button scrolls through the recorded songs in order from the newest (most recently recorded) to the oldest.
- The **44 (+)** button scrolls from the old to the new.

#### 3. Start playback.

- For details about how to do this, see “Starting and Stopping Playback” in “Operations Common to All Modes” (page E-11).
- To scroll back, hold down the **22 (SONG)** button as you press the **23 (REW)** button. To scroll forward, hold down the **22 (SONG)** button as you press the **24 (FF)** button. This operation can be performed only while an audio file is playing back.
- You can pause playback by holding down the **22 (SONG)** button as you press the **25 (PAUSE)** button. This operation can be performed only while an audio file is playing back.
- A MIDI file (SMF) and audio file cannot be played back simultaneously.
- To exit the Audio Recorder, press the **47 (AUDIO RECORDER)** button the required number of times until its lamp goes out.

## Deleting an Audio File from a USB Flash Drive

Files can be deleted one at a time.



### IMPORTANT!

- The procedure below deletes all of the data of the selected song. Note that the delete operation cannot be undone. Check to make sure you really do not need the file in USB flash drive before you perform the following steps.
1. Press the **47 (AUDIO RECORDER)** button the required number of times until the button lamp is lit.
  2. Use the **44 (-, +)** buttons to select the song you want to delete.
    - The **44 (-)** button scrolls through the recorded songs in order from the newest (most recently recorded) to the oldest.
    - The **44 (+)** button scrolls from the old to the new.
    - After selecting a song, you can play it back by pressing the **27 (START/STOP)** button. Press the **27 (START/STOP)** button again to stop playback.
  3. Press the **42 (ENTER)** button.
 

This will display a confirmation message "SURE?".

    - To cancel the delete operation, press the **44 (NO)** button.
  4. To delete the file, press the **44 (YES)** button.
 

This will delete the file you selected.



### NOTE

- The file number of file you delete remains unused. Recording a new file will cause the file number that comes after the last file recorded to the USB flash drive.

# Using the Stage Setups

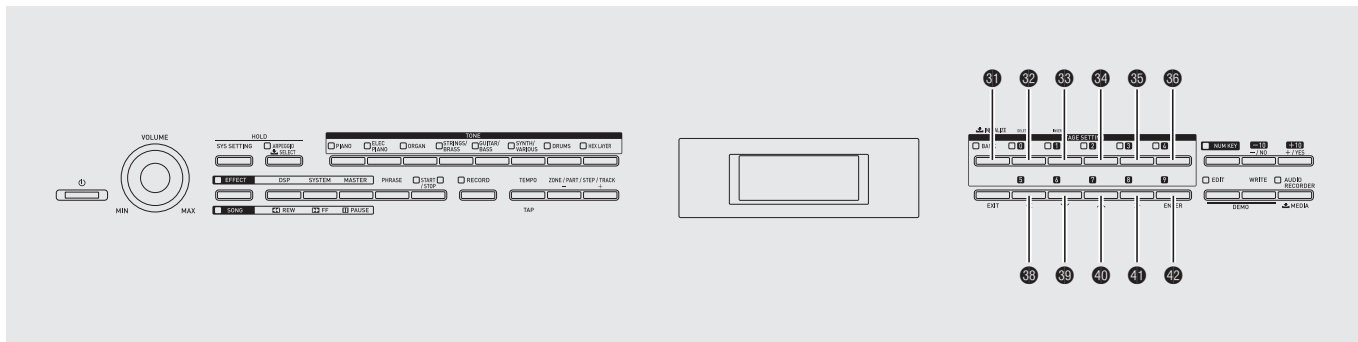

## Overview

Your Digital Piano supports simultaneous play of up to four tones on the keyboard. In addition to tone assignments, you can also save effect, arpeggio, and other settings as a stage setup (called a “Stage Setting”), which can be easily recalled at any time, even while you are playing, to instantly change the Digital Piano’s setup.

- You can have up to 100 stage setups (numbered 0-0 to 9-9) stored in Digital Piano memory.

## Recalling a Stage Setup

1. Press the **31 (BANK)** button.  
This will cause the button’s lamp to light.
2. Specify a bank and stage setup (Stage Setting) number.
  - First, holding down the **31 (BANK)** button, use buttons **32** through **36** or buttons **38** through **42** to specify the bank number.
  - Next, use buttons **32** through **36** or buttons **38** through **42** to specify the stage setup number.

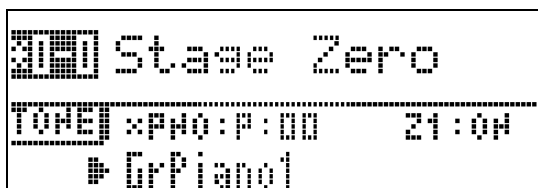

### NOTE

- After specifying the stage setup number, edit the stage setup contents and save the results. For details about how to display the editing screen, see “Using the Editing Function” in “Operations Common to All Modes” (page E-13).

## Playing the Zone 1 Tone on all Keys

For details about zone parts, see the separate “Tutorial”.

1. Hold down the **31 (BANK)** button until its lamp starts to flash.

This sets up the keyboard so all keys will sound the tone selected for Zone 1. It also causes Stage Setup settings to change to presets that are optimized for the selected tone.

- For details about parameters that can be edited, see the separate “Tutorial”.

# Other Useful Functions

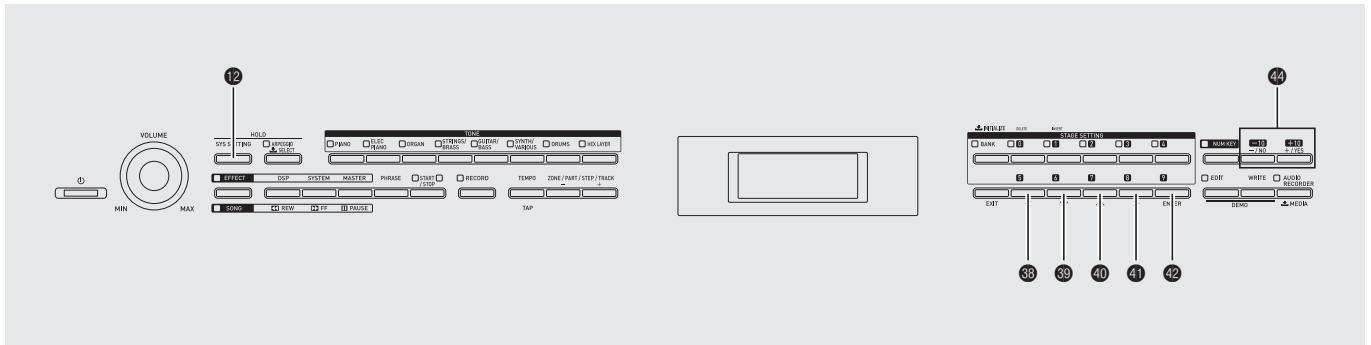

## System Settings

The Digital Piano settings listed below can be configured using the system setting (SYS SETTING) menu.

- Display contrast
- Initial power on mode
- Auto power off (page E-6) on/off
- Panel lock

1. Press **12** (SYS SETTING).
2. Use the **39** (▼), **40** (▲) buttons to select “General”.



3. Press **42** (ENTER).
4. Use the **38** (<), **39** (▼), **40** (▲), and **41** (>) buttons to select the item whose setting you want to configure.
5. Change the setting.
  - For details about how to do this, see “Changing a Number or a Value” in “Operations Common to All Modes” (page E-9).

## Settings

Display	Description	Settings
LCD Contrast	Display contrast (LCD Contrast). Adjusts the contrast of the display.	1 to 17
Auto Resume	Auto storage of settings (Auto Resume). When this setting is on, the Digital Piano remembers its current settings when it is turned off, and restores them the next time power is turned on.	Off, On
Auto Power Off	Auto Power Off function on/off (Auto Power Off). Turning off this setting disables Auto Power Off (page E-6).	Off, On
Panel Lock	Panel Lock (Panel Lock). When this setting is turned on, the Digital Piano’s buttons (except for the <b>10</b> (⏻) power button and buttons required for unlock) are locked, so no operation can be performed. Turn on panel lock when you want to protect against unintentional button operations.	Off, On

6. After settings are the way you want, press the **12** (SYS SETTING) button to exit the setting screen.

## Deleting Data

Use the procedure below to delete specific edited or recorded data (tones, arpeggios, phrases, songs, stage setups) from Digital Piano memory.

1. Press the **12 (SYS SETTING)** button.

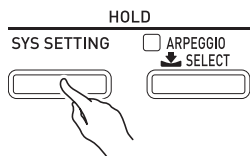

2. Use the **39 (∇)** and **40 (∧)** buttons to select “Initialize”.

3. Use the **38 (<)**, **39 (∇)**, **40 (∧)**, and **41 (>)** buttons to select the type of data you want to delete.

- To delete one stage setup: Init Stage Set
- To delete one user tone: Init Tone
- To delete one user arpeggio: Clear Arpeggio
- To delete one recorded phrase: Clear Phrase
- To delete one recorded song: Clear Song Seq
- To delete all data: Initialize All

4. Select the number of the data you want to delete.

- For details about how to do this, see “Changing a Number or a Value” in “Operations Common to All Modes” (page E-9).
- If you selected “Initialize All” in step 3 of the above procedure, you do not need to select a data number here.

5. Press the **42 (ENTER)** button.

This will display a confirmation message “SURE?”.

- If you want to cancel the delete operation, press the **44 (NO)** or **37 (EXIT)** button.

6. Press the **44 (YES)** button.

The message “Please Wait” will remain on the display while the operation is being performed. Do not perform any operation while this message is on the display. “Complete” appears on the display after data delete is complete.

- **For information about other setting items that appear on the display when the **12 (SYS SETTING)** button is pressed, see the separate “Tutorial”.**

# USB Flash Drive

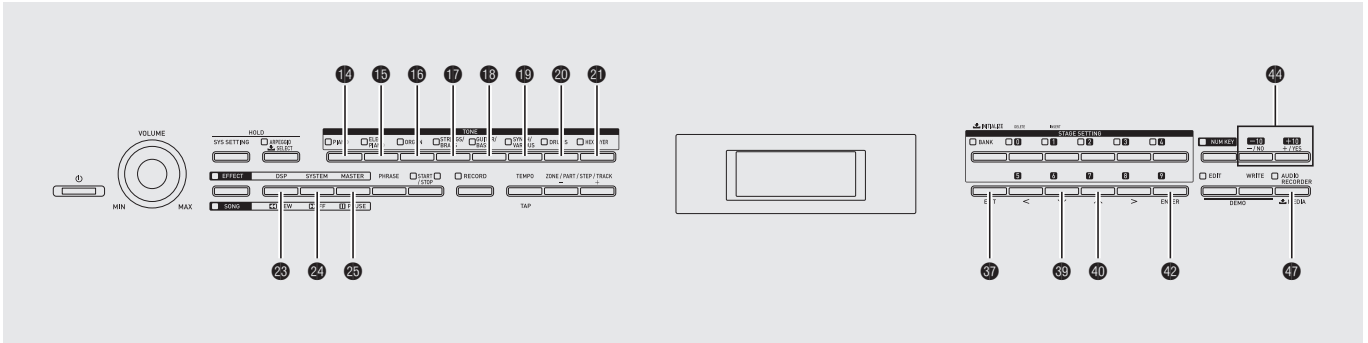

Your Digital Piano supports the following USB flash drive operations.

- USB flash drive formatting
- Data storage to a USB flash drive
  - Stage setups, tones, arpeggio, and phrase sequencer data edited with the Digital Piano can be saved on a USB flash drive.
  - Song data recorded with the Digital Piano’s song sequencer is on a USB flash drive as MIDI files (SMF format 0).
  - Digital Piano play can be recorded directly to a USB flash drive.  
For details, see “Recording to a USB Flash Drive” (page E-23).
- USB flash drive data loading to Digital Piano memory
- Delete data from a USB flash drive
- Easy play back of song data from a USB flash drive

## ■ Types of Data

Data Type	Description (File Name Extension)	Supported Operations	
		Save to USB Flash Drive	Load from USB Flash Drive
Stage Setting (page E-26)	Stage setup data edited with this Digital Piano (ZPF)	<input type="radio"/>	<input type="radio"/>
Tone (Page E-14)	The following tone data, edited with this Digital Piano <ul style="list-style-type: none"> <li>• Melody tone data (ZTN)</li> <li>• Hex Layer Tone data (ZLT)</li> <li>• Drum sound data (ZDR)</li> </ul>	<input type="radio"/>	<input type="radio"/>
Arpeggio (page E-17)	Arpeggio data edited with this Digital Piano (ZAR)	<input type="radio"/>	<input type="radio"/>
Phrase Sequencer (page E-18)	Phrase sequencer data edited with this Digital Piano (ZPH)	<input type="radio"/>	<input type="radio"/>
Song sequencer (page E-21)	Song sequencer data edited with this Digital Piano (ZSQ)	<input type="radio"/> *	<input type="radio"/>
All data	All of the above data (ZAL)	<input type="radio"/>	<input type="radio"/>

\* Can be saved as a MIDI file (SMF format 0).

## Storing Standard Audio Data (WAV Files) to a USB Flash Drive

Performing a record operation with the Digital Piano's audio recorder stores the data as a WAV file (automatically assigned a name from TAKE00.WAV to TAKE99.WAV) in the MUSICDAT folder (which is created automatically by the format operation) on the USB flash drive. You also can connect a USB flash drive to a computer and change the names of audio data (WAV) files to the format "TAKExx.WAV"\*, and move them to the MUSICDAT folder. Then you will be able to play them back on the Digital Piano.

\* xx = 00 to 99

## USB Flash Drive and USB Flash Drive Port Handling Precautions

### IMPORTANT!

- Be sure to observe the precautions provided in the documentation that comes with the USB flash drive.
- Avoid using a USB flash drive under the following conditions. Such conditions can corrupt data stored on the USB flash drive.
  - Areas subjected to high temperature, high humidity, or corrosive gas
  - Areas subjected to strong electrostatic charge and digital noise
- Never remove the USB flash drive while data is being written to or loaded from it. Doing so can corrupt the data on the USB flash drive and damage the USB flash drive port.
- Never insert anything besides a USB flash drive into the USB flash drive port. Doing so creates the risk of malfunction.
- A USB flash drive can become warm after very long use. This is normal and does not indicate malfunction.
- Static electricity conducted to the USB flash drive port from your hand or from a USB flash drive can cause malfunction of the Digital Piano. If this happens, turn the Digital Piano off and then back on again.

### Copyrights

You are allowed to use recordings for your own personal use. Any reproduction of an audio or music format file, without the permission of its copyright holder, is strictly prohibited under copyright laws and international treaties. Also, making such files available on the Internet or distributing them to third parties, regardless of whether such activities are conducted with or without compensation, is strictly prohibited under copyright laws and international treaties. CASIO COMPUTER CO., LTD. shall not be held in any way liable for any use of this Digital Piano that is illegal under copyright laws.

## Connecting a USB Flash Drive to and Detaching It from the Digital Piano

### IMPORTANT!

- When you plug in a USB flash drive, the Digital Piano initially needs to "mount" the USB flash drive and prepare for data exchange. Note that Digital Piano operations are momentarily disabled while a USB flash drive mounting sequence is being performed. While the mounting process is in progress, the message "Mounting Media" will be displayed on the display. It may take up to 10 or 20 seconds or even longer for a USB flash drive to be mounted. Do not attempt to perform any operation on the Digital Piano while a mounting sequence is in progress. A USB flash drive needs to be mounted each time it is connected to the Digital Piano.
- If you turn on the Digital Piano while USB flash drive is plugged into the Digital Piano, the mount operation described above will need to be performed, and Digital Piano operation will be disabled during that time.
- Never plug any other device besides a USB flash drive into the USB flash drive port.



## ■ To insert a USB flash drive

- As shown in the illustration below, insert the USB flash drive into the Digital Piano's USB flash drive port (43).
  - Carefully push the USB flash drive in as far as it will go. Do not use undue force when inserting the USB flash drive.

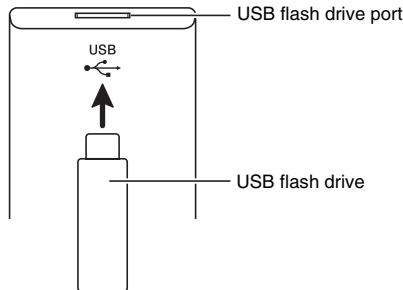

## ■ To remove a USB flash drive

- Check to confirm that there is no data exchange operation being performed, and then pull the USB flash drive straight out.

## Formatting a USB Flash Drive

### 👉 IMPORTANT!

- Be sure to format a USB flash drive on the Digital Piano before using it for the first time.
- Before formatting a USB flash drive, make sure it does not have any valuable data stored on it.
- The format operation performed by this Digital Piano is a "quick format". If you want to completely delete all of the data in USB flash drive, format it on your computer or some other device.

## Supported USB Flash Drives

This Digital Piano supports USB flash drives formatted to FAT32. If your USB flash drive is formatted to a different file system, use the Windows format function to reformat it to FAT32. Do not use quick format. The following types of USB flash drives are not supported.

- A USB flash drive that is recognized as multiple drives by the computer
  - A USB flash drive that is recognized as a CD-ROM by the computer
  - A USB flash drive that has an anti-virus function, security function, or other special function
- Insert the USB flash drive you want to format into the Digital Piano's USB flash drive port (43).
  - Hold down the 47 (MEDIA) button until the "MEDIA" screen appears.

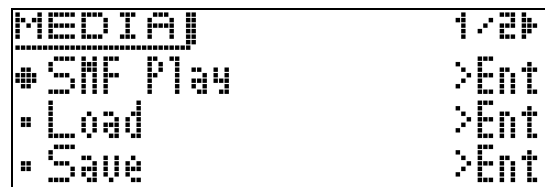

- Use the 39 (V) and 40 (^) buttons to select "Format".
- Press the 42 (ENTER) button.
 

This will display a confirmation message "SURE?".

  - If you want to cancel the format operation, press the 44 (NO) or 37 (EXIT) button.
- Press the 44 (YES) button.
 

The message "Please Wait" will remain on the display while the format operation is being performed. Do not perform any Digital Piano operation while this message is on the display. "Complete" appears on the display after formatting is complete.

## Saving Digital Piano Data to a USB Flash Drive

Use the following procedure to save Digital Piano data to a USB flash drive.

- The following types of data can be stored to USB flash drive.  
Stage setups, tones, arpeggios, phrases, song sequencer data, all data
1. Insert the USB flash drive into the Digital Piano's USB flash drive port (48).
  2. Hold down the 47 (MEDIA) button until the "MEDIA" screen appears.
  3. Use the 39 (∨) and 40 (∧) buttons to select "Save".
  4. Press the 42 (ENTER) button.
  5. Use the 39 (∨) and 40 (∧) buttons to select a data type of the data you want to save.
    - You can select one of the data types below.  
Stage setups (Stage Setting), tones (Tone), arpeggios (Arpeggio), phrases (Phrase), song sequencer data (Song Seq), all data (All Data)
    - To save a song sequencer data as a MIDI file (SMF), select "Song Seq" and then press the 42 (ENTER) button. Next, select "SMF Save" and then press the 42 (ENTER) button again.
  6. Press the 42 (ENTER) button.
  7. Specify the number of the data you want to save to the USB flash drive.
    - For details about how to do this, see "Changing a Number or a Value" in "Operations Common to All Modes" (page E-9).
    - When saving a tone, you can use buttons 14 through 21 (tone group) to select the type of file being saved.
  8. Press the 42 (ENTER) button.  
This will display a confirmation message "SURE?".
    - If you want to cancel the save, press the 44 (NO) or 37 (EXIT) button.
  9. Press the 44 (YES) button.  
The message "Please Wait" will remain on the display while the save operation is being performed. Do not perform any Digital Piano operation while this message is on the display. "Complete" appears on the display after data save is complete.
    - If there is already a file with the same name on the USB flash drive, a message "Replace?" will appear asking if you want to overwrite it with the new data. Press the 44 (YES) button to overwrite or the 44 (NO) button to cancel the save operation.

## ■ USB Flash Drive Data (File) Storage Locations

The above procedure stores Digital Piano data in a folder named MUSICDAT on the USB flash drive.

- The above data folders are created automatically when you format the USB flash drive on the Digital Piano (page E-31).
- Note that a file not in one of the data folders cannot be loaded, deleted, or renamed by the Digital Piano. You also will not be able to recall, delete, or play any file stored in any subfolder inside one of the data folders.

## Loading Data from a USB Flash Drive to Digital Piano Memory

You can use the procedure below to load data from a USB flash drive into Digital Piano memory.

1. Insert the USB flash drive into the Digital Piano's USB flash drive port (48).
2. Hold down the 47 (MEDIA) button until the "MEDIA" screen appears.
3. Use the 39 (∨) and 40 (∧) buttons to select "Load".
4. Press the 42 (ENTER) button.
5. Use the 39 (∨) and 40 (∧) buttons to select a data type of the data you want to load.
  - You can select one of the data types below.  
Stage setups (Stage Setting), tones (Tone), arpeggios (Arpeggio), phrases (Phrase), song sequencer data (Song Seq), all data (All Data)
6. Press the 42 (ENTER) button.
7. Specify the number of the data you want to load from the USB flash drive.
  - For details about how to do this, see "Changing a Number or a Value" in "Operations Common to All Modes" (page E-9).
  - When loading a tone, you can use buttons 14 through 21 (tone group) to select the type of file being loaded.
    - 14 (PIANO) to 19 (SYNTH/VARIOUS) buttons: Melody tone data (ZTN)
    - 20 (DRUMS) button: Drum sound data (ZDR)
    - 21 (HEX LAYER) button: Hex layer tone data (ZLT)
8. Press the 42 (ENTER) button.  
This will display a confirmation message "SURE?".
  - If you want to cancel the data load, press the 44 (NO) or 37 (EXIT) button.

**9.** Press the **44 (YES)** button.

The message "Please Wait" will remain on the display while the load operation is being performed. Do not perform any Digital Piano operation while this message is on the display. "Complete" appears on the display after data loading is complete.

- If there already is a file with the same name in the Digital Piano memory, a message "Replace?" will appear asking if you want to replace it with the new data. Press the **44 (YES)** button to overwrite or the **44 (NO)** button to cancel the load operation.

## Deleting Data from a USB Flash Drive

Use the following procedure to delete USB flash drive data (files).

1. Insert the USB flash drive into the Digital Piano's USB flash drive port (**48**).
2. Hold down the **47 (MEDIA)** button until the "MEDIA" screen appears.
3. Use the **39 (∨)** and **40 (∧)** buttons to select "Delete".
4. Press the **42 (ENTER)** button.
5. For the remainder of this procedure, perform the steps starting from step 7 under "Loading Data from a USB Flash Drive to Digital Piano Memory" (page E-32).

## Renaming a USB Flash Drive File

Use the following procedure to change the file name of a file on a USB flash drive.

1. Insert the USB flash drive into the Digital Piano's USB flash drive port (**48**).
2. Hold down the **47 (MEDIA)** button until the "MEDIA" screen appears.
3. Use the **39 (∨)** and **40 (∧)** buttons to select "Rename".
4. Press the **42 (ENTER)** button.
5. For the remainder of this procedure, perform the steps starting from step 7 under "Loading Data from a USB Flash Drive to Digital Piano Memory" (page E-32).
  - For details about how to input characters, see "Inputting Text Characters" in "Operations Common to All Modes" (page E-10).
  - The characters you can select are shown below.

0	1	2	3	4	5	6	7	8	9
A	B	C	D	E	F	G	H	I	J
K	L	M	N	O	P	Q	R	S	T
U	V	W	X	Y	Z	\$	&	_	'
(	)	-	^	{	}	@	~	`	

## Playing Back Audio Data Stored on a USB Flash Drive

You can use your Digital Piano to play back audio data (WAV files\*) stored on a commercially available USB flash drive.

See “USB Flash Drive” on page E-29 for more information.

\* Linear PCM, 16bit, 44.1 kHz, Stereo

### PREPARATION

- Prepare a USB flash drive that contains data recorded to it using the Digital Piano’s Audio Recorder. See “Recording to a USB Flash Drive” on page E-23 for more information.
- You can also use a computer to save audio data (WAV file) to the USB Flash Drive for playback. See “Storing Standard Audio Data (WAV Files) to a USB Flash Drive” on page E-30 for more information.
- Insert the USB flash drive that contains the data you want to play back into your Digital Piano’s USB flash drive port.

1. Press the **47 (AUDIO RECORDER)** button the required number of times until the button lamp is lit.

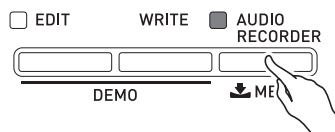

This will display the audio file selection screen.

2. Use the **44 (-, +)** buttons to select a song.
  - The **44 (+)** button scrolls forward through the song file names (TAKE00.WAV, TAKE01.WAV, etc.) The **44 (-)** button scrolls backward through the song file names.
3. Start playback.
  - For details about how to do this, see “Starting and Stopping Playback” in “Operations Common to All Modes” (page E-11).
  - To exit the Audio Recorder, press the **47 (AUDIO RECORDER)** button the required number of times until its lamp goes out.

## Playing Back a MIDI File Stored on a USB Flash Drive

You can use your Digital Piano to play back MIDI files (SMF) stored on a commercially available USB flash drive.

### PREPARATION

- Use a computer to move the MIDI file (SMF) you want to play into the MUSICDAT folder on the USB flash drive.

1. Plug the USB flash drive into the Digital Piano’s USB flash drive port (**48**).
2. Hold down the **47 (MEDIA)** button until the message “MEDIA” appears on the Digital Piano display.
3. Use the **39 (∇)** and **40 (∧)** buttons to select “SMF Play”.
4. Press the **42 (ENTER)** button.
5. Specify the number of the MIDI file (SMF) you want to play.
  - For details about how to do this, see “Changing a Number or a Value” in “Operations Common to All Modes” (page E-9).
6. Start playback.
  - For details about how to do this, see the steps starting from step 2 under “Starting and Stopping Playback” in “Operations Common to All Modes” (page E-11).
  - Use the **23 (REW)** button to scroll back measure-by-measure, or the **24 (FF)** button to scroll forward.
  - You can pause playback by pressing the **25 (PAUSE)** button.

## Error Messages

One of the error messages below appears on the display when a problem occurs.

- Press the **EXIT** button to clear an error message.

Display Message	Cause	Action
<b>No Media</b>	<ol style="list-style-type: none"> <li>1. The USB flash drive is not connected to the Digital Piano's USB flash drive port.</li> <li>2. The USB flash drive was removed while some operation was in progress.</li> <li>3. The USB flash drive is write-protected.</li> <li>4. The USB flash drive has anti-virus software.</li> </ol>	<ol style="list-style-type: none"> <li>1. Correctly plug the USB flash drive into the USB flash drive port.</li> <li>2. Do not remove the USB flash drive while any operation is in progress.</li> <li>3. Unprotect the USB flash drive.</li> <li>4. Use a USB flash drive that does not have anti-virus software.</li> </ol>
<b>No File</b>	There is no loadable or playable file in the "MUSICDAT" folder.	Move the file you want to load into the appropriate location (pages E-30, 32) in the "MUSICDAT" folder.
<b>No Data</b>	You are attempting to save data to a USB flash drive when there is no data to save.	Record something before performing a save operation.
<b>Read Only</b>	A read-only file with the same name you are trying to use is already stored on USB flash drive.	<ul style="list-style-type: none"> <li>• Change the name and then save the new data.</li> <li>• Remove the read-only attribute from the existing USB flash drive file and overwrite it with the new data.</li> <li>• Use a different USB flash drive.</li> </ul>
<b>Media Full</b>	There is not enough space available on the USB flash drive.	Delete some of the files on the USB flash drive to make room for new data (page E-33) or use a different USB flash drive.
<b>Too Many Files</b>	<ol style="list-style-type: none"> <li>1. There are too many files on the USB flash drive.</li> <li>2. There is a file named TAKE99.WAV in the "MUSICDAT" folder.</li> </ol>	<ol style="list-style-type: none"> <li>1. Delete some of the files on the USB flash drive to make room for new data.</li> <li>2. Delete the WAV file in the "MUSICDAT" folder.</li> </ol>
<b>Not SMF01</b>	You are attempting to play back song data that is not SMF Format 0 or Format 1.	This Digital Piano supports playback of SMF Format 0 or Format 1 only.
<b>Size Over</b>	<ol style="list-style-type: none"> <li>1. The data on the USB flash drive is too big to play.</li> <li>2. The SMF file size exceeded 320KB during SMF save.</li> <li>3. The phrase data you are trying to load is too large to be imported into Digital Piano memory. <ul style="list-style-type: none"> <li>• The maximum allowable size of a phrase file for import is approximately 8KB.</li> <li>• The maximum allowable total size of phrase files that can be imported is approximately 1MB (up to 1,000 files).</li> </ul> </li> </ol>	<ol style="list-style-type: none"> <li>1 and 2. This Digital Piano supports playback of song data files with a maximum size of 320KB.</li> <li>3. Delete some of the data currently in Digital Piano memory to free up available space.</li> </ol>
<b>Wrong Data</b>	<ol style="list-style-type: none"> <li>1. The USB flash drive data is corrupted.</li> <li>2. USB flash drive contains data that is not supported by this Digital Piano.</li> </ol>	—
<b>Memory Full</b>	There is not enough Digital Piano memory available to convert a song sequencer song to SMF data and store it on the USB flash drive.	Reduce the size of the song data. Example: Delete any tracks that are not required.
<b>Format Error</b>	<ol style="list-style-type: none"> <li>1. The USB flash drive format is not compatible with this Digital Piano.</li> <li>2. The USB flash drive is corrupted.</li> </ol>	<ol style="list-style-type: none"> <li>1. Format the USB flash drive on the Digital Piano.</li> <li>2. Use a different USB flash drive.</li> </ol>
<b>Media Error</b>	The USB flash drive is corrupted.	Use a different USB flash drive.
<b>Filename Error</b>	You are attempting to rename a USB flash drive file with a file name that is already used by another file on the USB flash drive.	Rename to a different file name.

# Connecting to a Computer

You can connect the Digital Piano to a computer and exchange MIDI data between them. You can send play data from the Digital Piano to commercially available music software running on your computer, or you can send MIDI data from your computer to the Digital Piano for playback.

## Minimum Computer System Requirements

The following shows the minimum computer system requirements for sending and receiving MIDI data. Check to make sure that your computer complies with these requirements before connecting the Digital Piano to it.

### ● Operating System

Windows® XP (SP2 or later)\*<sup>1</sup>

Windows Vista® \*<sup>2</sup>

Windows® 7 \*<sup>3</sup>

Windows® 8 \*<sup>4</sup>

Mac OS® X (10.3.9, 10.4.11, 10.5.X, 10.6.X, 10.7.X, 10.8.X)

\*1: Windows XP Home Edition

Windows XP Professional (32-bit)

\*2: Windows Vista (32-bit)

\*3: Windows 7 (32-bit, 64-bit)

\*4: Windows 8 (32-bit, 64-bit)

### ● USB port

#### **IMPORTANT!**

- Never connect to a computer that does not conform to the above requirements. Doing so can cause problems with your computer.

## Connecting the Digital Piano to Your Computer

#### **IMPORTANT!**

- Make sure you follow the steps of the procedure below exactly. Connecting incorrectly can make data send and receive impossible.

1. Turn off the Digital Piano and then start up your computer.
  - Do not start up the music software on your computer yet!
2. After starting up your computer, use a commercially available USB cable to connect it to the Digital Piano.

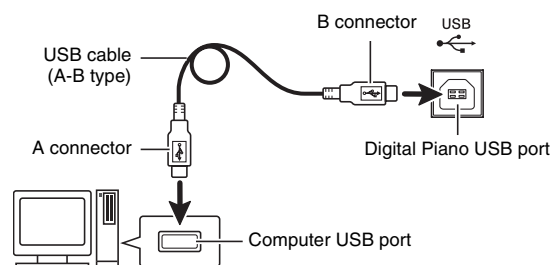

3. Turn on the Digital Piano.
  - If this is the first time you are connecting the Digital Piano to your computer, the driver software required to send and receive data will be installed on your computer automatically.
4. Start up commercially available music software on your computer.
5. Configure the music software settings to select one of the following as the MIDI device.
  - CASIO USB-MIDI : For Windows Vista, Windows 7, Windows 8, Mac OS X
  - USB Audio Device: For Windows XP
  - For information about how to select the MIDI device, see the user documentation that comes with the music software you are using.

#### **IMPORTANT!**

- Be sure to turn on the Digital Piano first before starting up your computer's music software.

 NOTE

- Once you are able to connect successfully, there is no problem with leaving the USB cable connected when you turn off your computer and/or Digital Piano.
- This Digital Piano conforms to General MIDI Level 1 (GM).
- For detailed specifications and connections that apply to MIDI data send and receive by this Digital Piano, see the latest support information provided by the website at the following URL.  
<http://world.casio.com/>

## Saving and Loading Digital Piano Data to a Computer and Editing Digital Piano Data on a Computer

You can transfer user tones, phrases, and other data you saved with the Digital Piano to a computer for storage. Later, you can return the data back to the Digital Piano when you need it.

You can also edit tone, stage setup and other Digital Piano data on a computer, where it is easier to work with. A special Data Editor application is required in order to perform operations such as these.

1. Go to the CASIO WORLDWIDE site at the following URL.  
<http://world.casio.com/>
2. At the site, select a geographic area or country.
3. After accessing the area site, navigate to the minimum computer system requirements for Data Editor for this product.
  - You should be able to find a link to Data Editor information on the product introduction page of this product. If you cannot find such a link, use the search form of the area site where you are located to enter the model name of this product and search for it.
  - Note that site contents are subject to change without notice.
4. Check if your computer system complies with the minimum requirements for Data Editor.
5. Download Data Editor and its user's guide to your computer.
6. Follow the procedure in the Data Editor user's guide you downloaded in step 5 to install Data Editor.
7. Use the procedures in the Data Editor user's guide to transfer and edit data.
  - See the Data Editor user's guide for information about the types of data that can be transferred and the data that can be edited.

# Reference

## Troubleshooting

Problem	Cause	Action	See Page
No sound is produced when I press a keyboard key.	<ol style="list-style-type: none"> <li>1. The <b>VOLUME</b> controller is set to “MIN”.</li> <li>2. This Digital Piano does not have built-in speakers. Nothing will sound if an output device is not connected.</li> </ol>	<ol style="list-style-type: none"> <li>1. Rotate the <b>VOLUME</b> controller more towards “MAX”.</li> <li>2. Connect audio equipment, an amplifier, or headphones.</li> </ol>	<p>☞ E-6</p> <p>☞ E-7</p>
The pitch of the Digital Piano is off.	<ol style="list-style-type: none"> <li>1. Digital Piano tuning is incorrect.</li> <li>2. The Digital Piano’s key setting is something other than “440.0 Hz”.</li> <li>3. A non-standard temperament setting is being used.</li> <li>4. Octave shift is enabled.</li> </ol>	<ol style="list-style-type: none"> <li>1. Adjust Digital Piano tuning, or turn the Digital Piano off and then back on again.</li> <li>2. Change the key setting to “440.0 Hz”, or turn Digital Piano power off and then back on again.</li> <li>3. Change the temperament setting to “00:Equal”, which is the standard modern tuning.</li> <li>4. Change the octave shift setting to 0.</li> </ol>	☞ Tutorial
Tones and/or effects sound strange. Turning power off and then back on again does not eliminate the problem. <i>Example: Note intensity does not change even though I alter key pressure.</i>	The “Auto Resume” feature is turned on.	Turn off “Auto Resume”. Next, turn power off and then back on again.	☞ E-27
Chorus, reverb, and/or delay are not being applied.	<ol style="list-style-type: none"> <li>1. Lower the system effect send and/or return level.</li> <li>2. A small value is selected for the effect setting of an effect parameter.</li> </ol>	<ol style="list-style-type: none"> <li>1. Change the system effect send and/or return levels to greater values.</li> <li>2. Select a larger value for the effect setting of the effect parameter.</li> </ol>	☞ Tutorial
I cannot transfer data after connecting the Digital Piano to a computer.	—	<ol style="list-style-type: none"> <li>1. Check to make sure that the USB cable is connected to the Digital Piano and computer, and that the correct device is selected with your computer’s music software.</li> <li>2. Turn off the Digital Piano and then exit the music software on your computer. Next, turn the Digital Piano back on and then restart the music software on your computer.</li> </ol>	☞ E-36
I cannot store data to a USB flash drive or load data from a USB flash drive.	—	See “Error Messages”.	☞ E-35
A tone’s quality and volume sounds slightly different depending where it is played on the keyboard.	<p>This is an unavoidable result of the digital sampling process*, and does not indicate malfunction.</p> <p>* Multiple digital samples are taken for the low range, middle range, and high range of the original musical instrument. Because of this, there may be a very slight difference in tonal quality and volume between sample ranges.</p>		
When I press a button, the note that is sounding cuts out momentarily or there is a slight change in how effects are applied.	Performing a button operation while playing with the recorder, or other functions can cause such phenomena when the Digital Piano switches internal tone effects. It does not indicate malfunction.		
Even though I play on different ranges of the keyboard, the notes do not change octaves.	The ranges of certain tones are limited, which means that octaves change normally up to a certain low note or high note. With such a tone, the notes of the lowest octave will be repeated to the left of the lowest possible note, and the highest octave will be repeated to the right of the highest possible note. This is due do limitations in the range of the original musical instrument for each tone, and does not indicate malfunction of the Digital Piano.		



## Product Specifications

Model	PX-5SWE
Sound Source	Multi-dimensional Morphing AiR
Keyboard	88-key piano keyboard, with Touch Response (3 levels, Off), High-Resolution Velocity, Key Off Velocity, Hammer Response
Maximum Polyphony	256 notes
Tones	370 preset, 350 user Melody Tones: 300 preset, 180 user Hex Layer Tones: 50 preset, 150 user PCM Drum Tones: 20 preset, 20 user
Effects	<ul style="list-style-type: none"> <li>• System Effects: Reverb, Chorus, Delay, Resonance</li> <li>• Master Effects: 4 band equalizer, Compressor</li> <li>• DSP: 20 types</li> </ul>
Number of Demo Songs	4
Number of Stage Setups	100
Phrase Sequencer	<ul style="list-style-type: none"> <li>• Number of Phrases: 1000</li> <li>• Number of Songs (Song Sequencer): 10</li> <li>• Playback Mode: One time, loop</li> <li>• Memory Capacity: Approximately 1MB</li> <li>• Other: Overdubbing, Note Quantize (for recording)</li> </ul>
Audio Recorder	<ul style="list-style-type: none"> <li>• Real-time recording and playback to USB flash drive* * Linear PCM, 16bit, 44.1 kHz, stereo .WAV format</li> <li>• Number of Songs: 100</li> <li>• Approximately 25 minutes maximum recording per song.</li> </ul>
Mixer	16 parts + Externally input parts
Other Functions	<ul style="list-style-type: none"> <li>• Transpose: <math>\pm 1</math> octaves (-12 to 0 to +12 semitones)</li> <li>• Octave Shift: <math>\pm 3</math> octaves</li> <li>• Tuning: A4 = 415.5 - 440.0 - 465.9 Hz</li> <li>• Temperaments: 17 types (including equal temperament)</li> <li>• Stretch Tune: 8 types</li> <li>• Number of Arpeggios: Preset: 100 User: 100</li> </ul>
MIDI	16 multi-timbre received, GM Level 1 standard
Main Controllers	Bender wheel, modulation wheel, knobs $\times 4$ , sliders $\times 6$
USB Flash Drive	SMF playback, playback of audio data, user data save/load
Inputs/Outputs	<ul style="list-style-type: none"> <li>• Pedal Jacks: Standard jacks <math>\times 2</math></li> <li>• Power: 12V DC (Power Consumption: 12V <math>\approx</math> 5W)</li> <li>• <b>PHONES</b> jacks: Stereo standard jacks <math>\times 2</math></li> <li>• <b>MIDI IN, OUT/THRU</b> terminals</li> <li>• <b>LINE OUT R, L/MONO</b> jacks: Standard jacks <math>\times 2</math> Output impedance: 2.3k<math>\Omega</math> Output voltage: 1.8V (RMS) MAX</li> <li>• <b>LINE IN R, L/MONO</b> jacks: Standard jacks <math>\times 2</math> Input impedance: 9.0k<math>\Omega</math> Input voltage: 200mV</li> <li>• <b>AUDIO IN</b> jack: Stereo mini jack Input Impedance: 9.0k<math>\Omega</math>, Input Sensitivity: 200mV</li> <li>• USB flash drive port : Type A</li> <li>• USB port: Type B</li> </ul>
Power Supply	2-way Batteries: 8 AA-size alkaline batteries Battery Life: Approximately 3 hours continuous operation on alkaline batteries AC Adaptor: AD-A12150LW Auto Power Off Time: Approximately 6 minutes after last key operation during battery use, approximately 4 hours after last key operation during AC adaptor use. Auto Power Off can be disabled.
Dimensions	132.2 (W) $\times$ 28.6 (D) $\times$ 13.5 (H) cm (52 $\frac{1}{16}$ $\times$ 11 $\frac{1}{4}$ $\times$ 5 $\frac{5}{16}$ inch)
Weight	Approximately 11.1kg (24.5lbs)

\* Based on 1KB = 1024bytes, 1MB = 1024<sup>2</sup> bytes

- Specifications and designs are subject to change without notice.
- Access the website below for the latest news about specifications and firmware versions.  
<http://world.casio.com/>

## Operating Precautions

Be sure to read and observe the following operating precautions.

### ■ Location

Avoid the following locations for this product.

- Areas exposed to direct sunlight and high humidity
- Areas subjected to temperature extremes
- Near a radio, TV, video deck, or tuner
- The above devices will not cause malfunction of the product, but the product can cause interference in the audio or video of a nearby device.

### ■ User Maintenance

- Never use benzine, alcohol, thinner, or other chemical agents to clean the product.
- To clean the product or its keyboard, wipe with a soft cloth moistened in a weak solution of water and a mild neutral detergent. Wring all excess moisture from the cloth before wiping.

### ■ Included and Optional Accessories

Use only accessories that are specified for use with this product. Use of unauthorized accessories creates the risk of fire, electric shock, and personal injury.

### ■ Weld Lines

Lines may be visible on the exterior of the product. These are “weld lines” that result from the plastic molding process. They are not cracks or scratches.

### ■ Musical Instrument Etiquette

Always be aware of others around you whenever using this product. Be especially careful when playing late at night to keep the volume at levels that do not disturb others. Other steps you can take when playing late at night are closing windows and using headphones.

- Any reproduction of the contents of this manual, either in part or its entirety, is prohibited. Except for your own, personal use, any other use of the contents of this manual without the consent of CASIO is prohibited under copyright laws.
- IN NO EVENT SHALL CASIO BE LIABLE FOR ANY DAMAGES WHATSOEVER (INCLUDING, WITHOUT LIMITATION, DAMAGES FOR LOSS OF PROFITS, BUSINESS INTERRUPTION, LOSS OF INFORMATION) ARISING OUT OF THE USE OF OR INABILITY TO USE THIS MANUAL OR PRODUCT, EVEN IF CASIO HAS BEEN ADVISED OF THE POSSIBILITY OF SUCH DAMAGES.
- The contents of this manual are subject to change without notice.

### ■ AC Adaptor Handling Precautions

- Use a power outlet that is easily accessible so you can unplug the AC adaptor when a malfunction occurs or whenever else you need to do so.
- The AC adaptor is intended for indoor use only. Do not use it where it might be exposed to splashing or moisture. Do not place any container, such as a flower vase, that contains liquid on the AC adaptor.
- Store the AC adaptor in a dry place.
- Use the AC adaptor in an open, well-ventilated area.
- Never cover the AC adaptor with newspaper, a table cloth, a curtain, or any other similar item.
- Unplug the AC adaptor from the power outlet if you do not plan to use the Digital Piano for a long time.
- Never try to repair the AC adaptor or modify it in any way.
- AC adaptor operating environment
  - Temperature: 0 to 40°C
  - Humidity: 10% to 90% RH
- Output polarity: 

## AC Adaptor Handling Precautions

### Model: AD-A12150LW

1. Read these instructions.
2. Keep these instructions on hand.
3. Heed all warnings.
4. Follow all instructions.
5. Do not use this product near water.
6. Clean only with a dry cloth.
7. Do not install near radiators, heat registers, stoves, or any other source of heat (including amplifiers).
8. Use only attachments and accessories specified by the manufacturer.
9. Refer all servicing to qualified service personnel. Servicing is required after any of the following occurs: when the product is damaged, when the power supply cord or plug is damaged, when liquid is spilled into the product, when a foreign object falls into the product, when the product is exposed to rain or moisture, when the product does not operate normally, when the product is dropped.
10. Do not allow the product to be exposed to dripping or splashing liquid. Do not place any object containing liquid on the product.
11. Do not allow the electrical load output to exceed the label rating.
12. Make sure the surrounding area is dry before plugging into a power source.
13. Make sure the product is oriented correctly.
14. Unplug the product during lightning storms or when you do not plan to use it for a long time.
15. Do not allow product ventilation openings to become blocked. Install the product in accordance with the manufacturer's instructions.
16. Take care the power cord is located where it will not be stepped upon or bent severely, particularly in locations close to plugs and convenience receptacles, and in locations where it exits from the product.
17. The AC adaptor should be plugged into a power outlet as close to the product as possible to allow immediate disconnection of the plug in case of emergency.

The symbol below is an alert indicating un-insulated hazardous voltage inside the product's enclosure, which may be sufficient to constitute the risk of electric shock to users.



The symbol below is an alert indicating the presence of important operating and maintenance (servicing) instructions in the documentation that accompanies the product.





This recycle mark indicates that the packaging conforms to the environmental protection legislation in Germany.

Esta marca de reciclaje indica que el empaquetado se ajusta a la legislación de protección ambiental en Alemania.

**CASIO®**



## Free Manuals Download Website

<http://myh66.com>

<http://usermanuals.us>

<http://www.somanuals.com>

<http://www.4manuals.cc>

<http://www.manual-lib.com>

<http://www.404manual.com>

<http://www.luxmanual.com>

<http://aubethermostatmanual.com>

Golf course search by state

<http://golfingnear.com>

Email search by domain

<http://emailbydomain.com>

Auto manuals search

<http://auto.somanuals.com>

TV manuals search

<http://tv.somanuals.com>