



# Dell™ 3130cn Color Laser Printer User's Guide

<a href="#">Dell™ 3130cn Color Laser Printer User's Guide</a>	<a href="#">Printing</a>
<a href="#">Finding Information</a>	<a href="#">Setting Up for Shared Printing</a>
<a href="#">About Your Printer</a>	<a href="#">Understanding Fonts</a>
<a href="#">Installing the Print Cartridges</a>	<a href="#">Understanding Printer Messages</a>
<a href="#">Connecting Your Printer</a>	<a href="#">Clearing Jams</a>
<a href="#">Dell Printer Configuration Web Tool</a>	<a href="#">Troubleshooting Guide</a>
<a href="#">Installing Optional Modules</a>	<a href="#">Installing Printer Drivers</a>
<a href="#">Print Media Guidelines</a>	<a href="#">Printing With Web Services on Devices (WSD)</a>
<a href="#">Loading Print Media</a>	<a href="#">Maintaining Your Printer</a>
<a href="#">Operator Panel</a>	<a href="#">Removing Options</a>
<a href="#">Printer Settings</a>	<a href="#">Printer Specifications</a>
<a href="#">Understanding the Tool Box Menus</a>	<a href="#">Printing With UX Filter (UNIX)</a>
<a href="#">Understanding the Printer Menus</a>	<a href="#">Printing With CUPS (Linux)</a>
<a href="#">Understanding Your Printer Software</a>	<a href="#">Appendix</a>

---

## Notes, Notices, and Cautions

-  **NOTE:** A **NOTE** indicates important information that helps you make better use of your printer.
-  **NOTICE:** A **NOTICE** indicates either potential damage to hardware or loss of data and tells you how to avoid the problem.
-  **CAUTION:** A **CAUTION** indicates a potential for property damage, personal injury, or death.

Information in this document is subject to change without notice.

© 2010 Dell Inc. All rights reserved.

Reproduction in any manner whatsoever without the written permission of Dell Inc. is strictly forbidden.

Trademarks used in this text: *Dell*, the *DELL* logo, *Inspiron*, *Dell Precision*, *Dimension*, *OptiPlex*, *Latitude*, *PowerEdge*, *PowerVault*, *PowerApp*, and *Dell OpenManage* are trademarks of Dell Inc.; *Intel*, *Pentium*, and *Celeron* are registered trademarks of Intel Corporation; *Microsoft*, *Windows*, *Windows Server*, *MS-DOS* and *Windows Vista* are either trademarks or registered trademarks of Microsoft Corporation in the United States and/or other countries. *EMC* is the registered trademark of EMC Corporation; *ENERGY STAR* is a registered trademark of the U.S. Environmental Protection Agency. As an ENERGY STAR Partner, Dell Inc. has determined that this product meets the ENERGY STAR guidelines for energy efficiency; *Adobe* and *Photoshop* are registered trademarks or trademarks of Adobe Systems Incorporated in the United States and/or other countries.

Other trademarks and trade names may be used in this document to refer to either the entities claiming the marks and names or their products. Dell Inc. disclaims any proprietary interest in trademarks and trade names other than its own.

Our printer software uses some of the codes defined by the Independent JPEG Group.

## UNITED STATES GOVERNMENT RESTRICTED RIGHTS

This software and documentation are provided with RESTRICTED RIGHTS. Use, duplication or disclosure by the Government is subject to restrictions as set forth in subparagraph (c)(1)(ii) of the Rights in Technical Data and Computer Software clause at DFARS 252.227-7013 and in applicable FAR provisions: Dell Inc., One Dell Way, Round Rock, Texas, 78682, USA.

September 2010 Rev. A03

# Dell™ 3130cn Color Laser Printer User's Guide

Click the links to the left for information on the features, options, and operation of your printer. For information on other documentation included with your printer, see ["Finding Information"](#).

## Front View

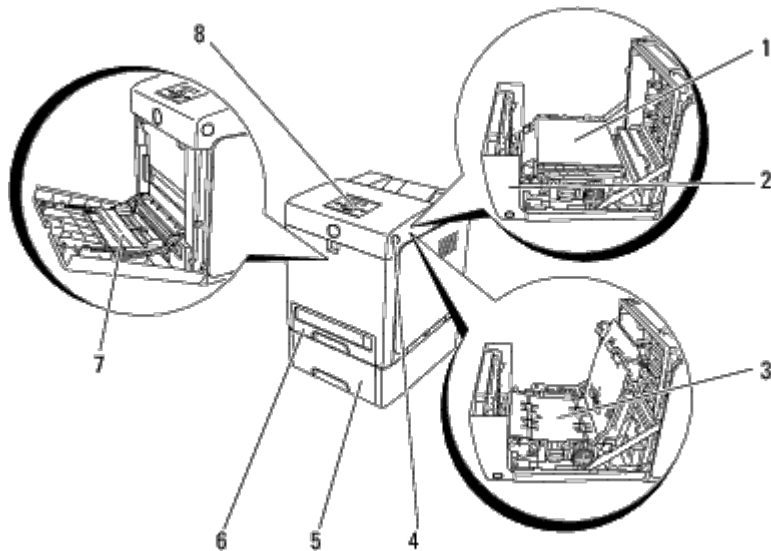

1	Belt Unit	5	550 Sheet Feeder (optional) <b>NOTE:</b> Your printer allows for a maximum of 3 trays (Tray 1, 550 sheet feeder, and MPF).
2	Front Cover <b>NOTE:</b> You can open the front cover by pressing the side button.	6	Tray 1
3	Duplexer (optional)	7	Multipurpose Feeder (MPF)
4	Side Button	8	Operator Panel

## Rear View

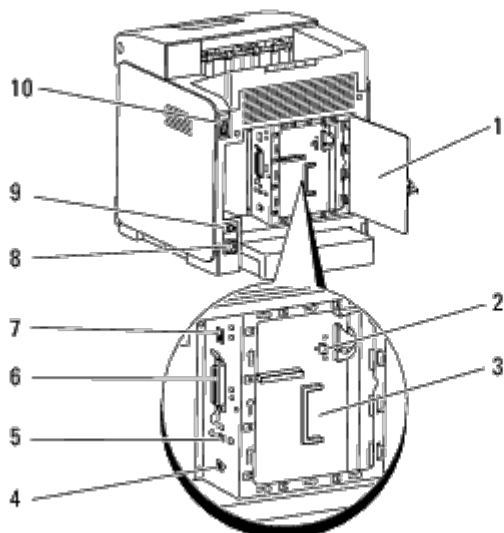

1	Control Board Cover	6	Parallel Port
2	Network Protocol Adapter Socket	7	Ethernet Port
3	Control Board	8	Power Connector
4	USB Port	9	Reset Button
5	Wireless Printer Adapter Socket	10	Power Switch

To order replacement toner cartridges or supplies from Dell:

1. Double-click the icon on your desktop.



If you cannot find the icon on your desktop, follow the procedure below.

- a. Click a **DLRMM.EXE** from "C:\Program Files\Dell Printers\Additional Color Laser Software\Reorder".

 **NOTE:** "C:\Program Files\" may be different depending on the destination of the folder which you installed the Dell software and documentation.

- b. Click **File** on the toolbar, and then **Create Shortcut** on the drop-down menu that appears.
  - c. Right-click on the shortcut icon that is created.
  - d. Choose **Send To** from the drop-down menu, and then click **Desktop (create shortcut)** on the submenu that appears.
2. Visit the Dell Printer Supplies website at [www.dell.com/supplies](http://www.dell.com/supplies), or order Dell printer supplies by phone.

For best service, have your Dell printer Service Tag available.

For help locating your Service Tag number, see ["Express Service Code and Service Tag number"](#).



---

[Back to Contents Page](#)

# Finding Information

 **NOTE:** The following are options you need to buy separately.

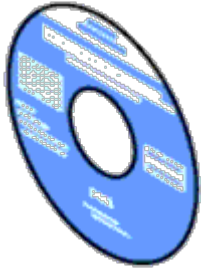
- USB cable
- Ethernet cable
- Parallel cable
- Wireless Printer adapter
- Network protocol adapter
- 550 sheet feeder
- Duplexer
- Hard disk
- 512 MB or 1024 MB memory

What are you looking for?	Find it here
<ul style="list-style-type: none"><li>• Drivers for my printer</li><li>• My <i>User's Guide</i></li></ul>	<p><i>Drivers and Utilities CD</i></p>  <p>The <i>Drivers and Utilities CD</i> contains Setup Video, documentation, and drivers for your printer. You can use the CD to uninstall/reinstall drivers or access the Setup Video and documentation.</p> <p>Readme files may be included on your CD to provide last-minute updates about technical changes to your printer or advanced technical reference material for experienced users or technicians.</p>
<ul style="list-style-type: none"><li>• How to use my printer</li></ul>	<p><i>Owner's Manual</i></p>  <p> <b>NOTE:</b> The <i>Owner's Manual</i> may not be available in your country or region.</p>
<ul style="list-style-type: none"><li>• Safety information</li><li>• Warranty information</li></ul>	<p><i>Product Information Guide</i></p>



**CAUTION:** Read and follow all safety instructions in your *Product Information Guide* prior to setting up and operating your printer.

How to set up my printer

Setup diagram



Troubleshooting

[Troubleshooting Guide](#)

Express Service Code and Service Tag number

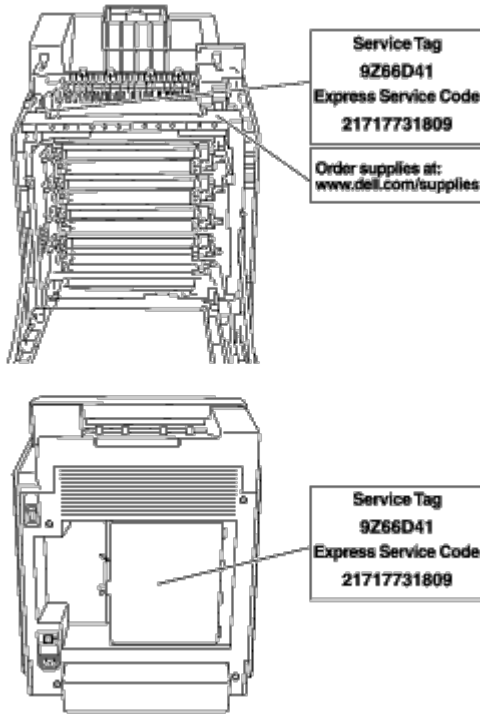

The Express Service Code and Service Tag numbers are located inside the front cover and outside the control board cover of your printer.

- Latest drivers for my printer
- Answers to technical service and support questions
- Documentation for my printer

See the Dell Support website at [support.dell.com](http://support.dell.com)

The Dell Support website, [support.dell.com](http://support.dell.com) provides several online tools, including:

- Solutions - Troubleshooting hints and tips, articles from technicians, and online courses
- Upgrades - Upgrade information for components, such as printer driver
- Customer Care - Contact information, order status, warranty, and repair information
- Downloads - Drivers
- Manuals - Printer documentation and product specifications

You can access the Dell Support website at [support.dell.com](http://support.dell.com). Select your region on the support page, and fill in the requested details to access help tools and information.

# About Your Printer

- [Operator Panel](#)
- [Protecting Your Printer](#)

The following illustrations show the standard Dell™ 3130cn Color Laser Printer.

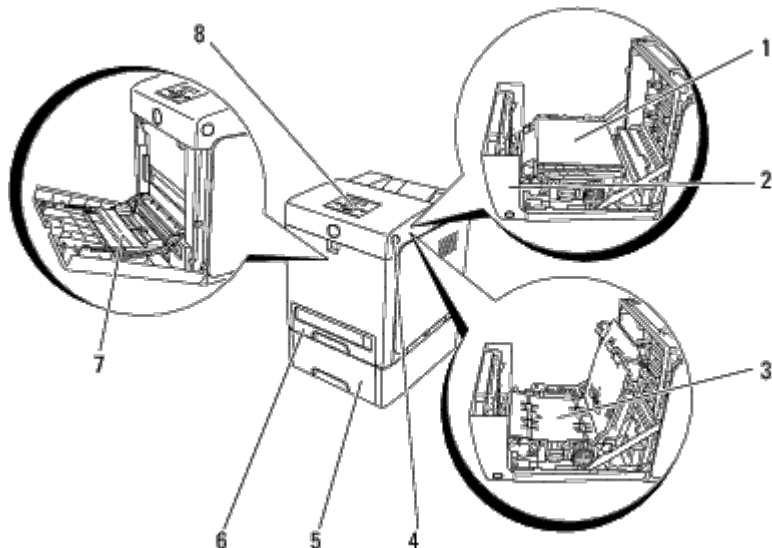

1	Belt Unit	5	550 Sheet Feeder (optional) <b>NOTE:</b> Your printer allows for a maximum of 3 trays (Tray 1, 550 sheet feeder, and MPF).
2	Front Cover <b>NOTE:</b> You can open the front cover by pressing the side button.	6	Tray 1
3	Duplexer (optional)	7	Multipurpose Feeder (MPF)
4	Side Button	8	Operator Panel

 **NOTE:** When you use the printer with the MPF opened, do not locate the printer in direct sunlight. Doing so may cause a malfunction or unnatural screen image.

Provide enough room to open the printer tray, covers, and option. It is also important to allow space around the printer for proper ventilation.

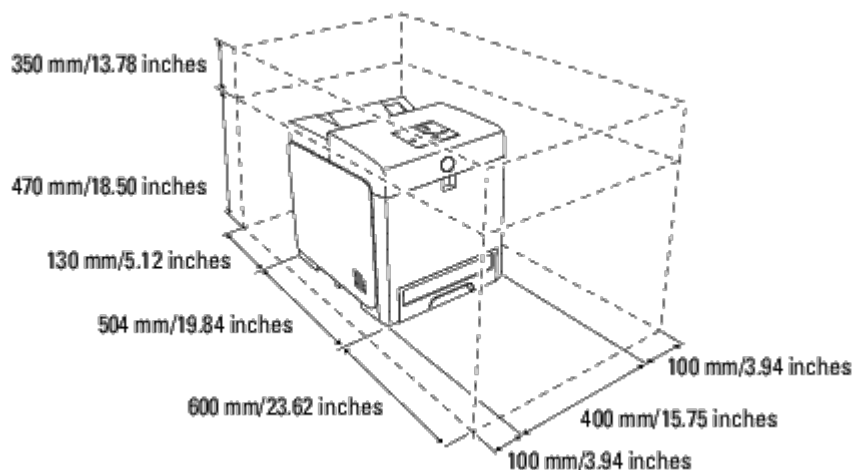

## Operator Panel



For details on the operator panel, see ["Operator Panel"](#).

---

## Protecting Your Printer

To protect your printer from theft, you can use the optional Kensington lock.

Attach the Kensington lock to the security slot of your printer.

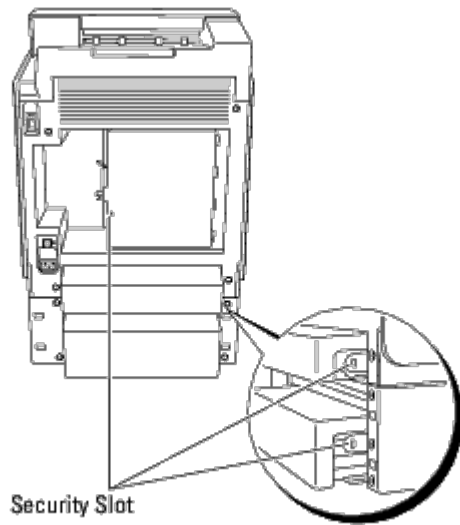

For details, see the operating instructions supplied with the Kensington lock.

---

[Back to Contents Page](#)

# Installing the Print Cartridges

## ● [Installing the Print Cartridges](#)

**⚠ CAUTION:** Before performing any of the following procedures, read and follow the safety instructions in your *Product Information Guide*.

**➡ NOTICE:** To protect the drums of the print cartridges against bright light, close the front cover within five minutes. If the front cover remains open for more than five minutes, print quality may deteriorate.

**➡ NOTICE:** Ensure that nothing touches or scratches the surface (black-colored film) of the belt unit. Scratches, dirt, or oil from your hands on the film of the belt unit may affect print quality.

---

## Installing the Print Cartridges

1. Press the side button and open the front cover.

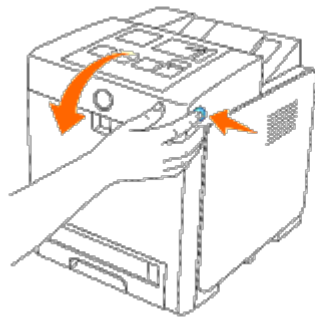

2. Remove the print cartridge inserted at the top cartridge slot by grasping both handles and pulling it out.

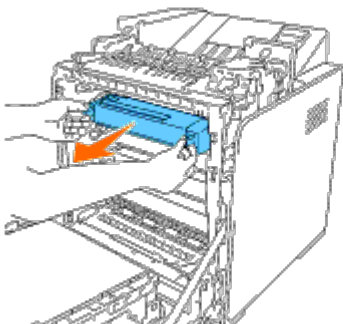

3. Shake the print cartridge 5 or 6 times to distribute the toner evenly.

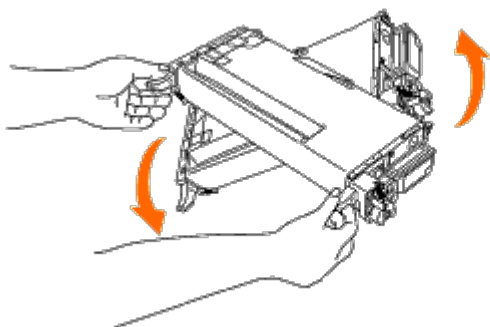

4. Pull out the orange-yellow tape completely from the cartridge. It is approximately 856 mm long.



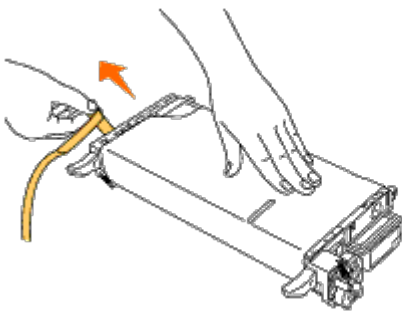

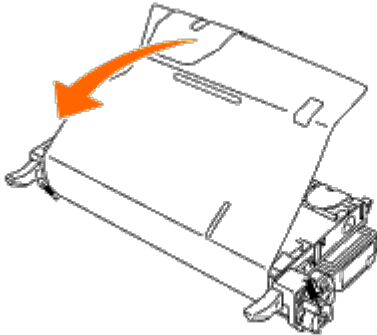

5. Remove the black protect cover from the print cartridge.

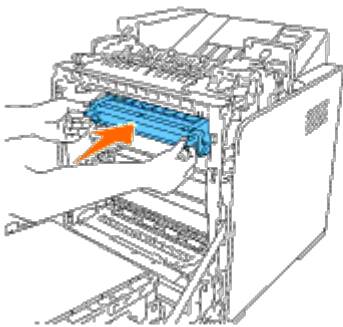

6. Grasp both handles of the print cartridge and slide the cartridge into the same color slot. Ensure the cartridge is fully inserted to the right slot.



 **NOTE:** The cartridge slots are lined up from above with the following order: Black, Cyan, Magenta, Yellow.

7. Repeat steps 2 to 6 to install the other print cartridges.

8. Remove the instruction sheet on the top of the printer.

9. After installing all of the print cartridges, close the front cover.

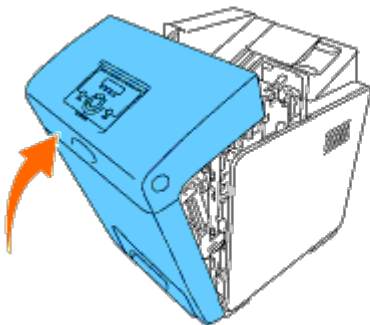





# Connecting Your Printer

- [Connecting the Printer Directly to a Computer](#)
- [Connecting the Printer to the Network](#)
- [Using the Reset Button](#)

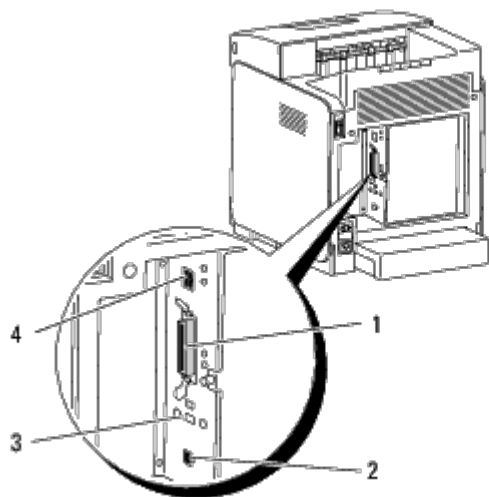
Your Dell™ 3130cn Color Laser Printer interconnection cable must meet the following requirements:

Connection type	Connection specifications
Parallel	IEEE 1284
USB	USB 2.0
Wireless	IEEE802.11b/802.11g
Ethernet	10 Base-T/100 Base-TX



1	Parallel Port	
2	USB Port	
3	Wireless Printer Adapter Socket	
4	Ethernet Port	

## Connecting the Printer Directly to a Computer

A local printer is a printer attached to your computer using a USB or parallel cable. If your printer is attached to a network instead of your computer, skip this section and go to "[Connecting the Printer to the Network](#)".

Microsoft® Windows® 2000, Windows XP, Windows XP 64-bit Edition, Windows Server® 2003, Windows Server 2003 x64 Edition, Windows Server 2008, Windows Server 2008 64-bit Edition, Windows Server 2008 R2 64-bit Edition, Windows Vista®, Windows Vista 64-bit Edition, Windows 7, Windows 7 64-bit Edition and Mac OS® X or later operating systems support USB connections. Some UNIX® and Linux computers also support USB connections. See your computer operating system documentation to see if your system supports USB.

To attach the printer to a computer:

1. Ensure that the printer, computer, and any other attached devices are turned off and unplugged.
2. Connect the printer to the computer using a USB or parallel cable.

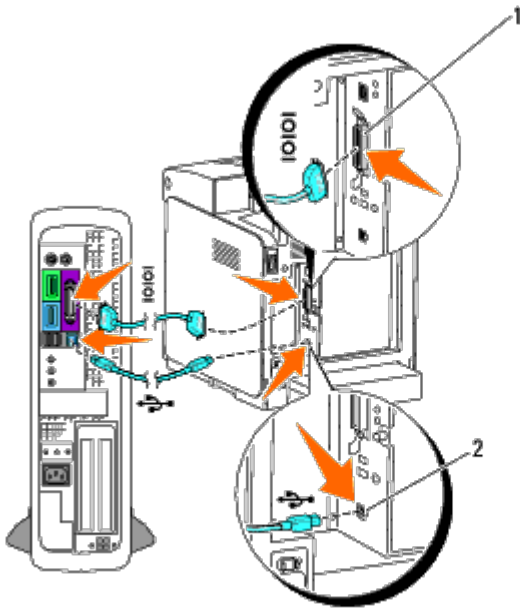

1	Parallel port
2	USB port

**NOTICE:** Do not plug a USB cable into the USB keyboard.

A USB/parallel port requires a USB/parallel cable. Ensure that you match the USB/parallel symbol on the cable to the USB/parallel symbol on the printer.

Plug the other end of the cable into a USB or parallel port on the back of the computer.

## Turn On the Printer

1. Connect the power cable to the printer and plug it into a power source.

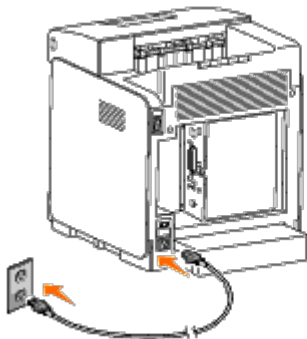

**CAUTION:** Do not use extension cords or power strips.

**CAUTION:** The printer should not be plugged into a UPS system.

2. Turn on the computer and the printer. When you use the USB cable, the USB driver is automatically installed.

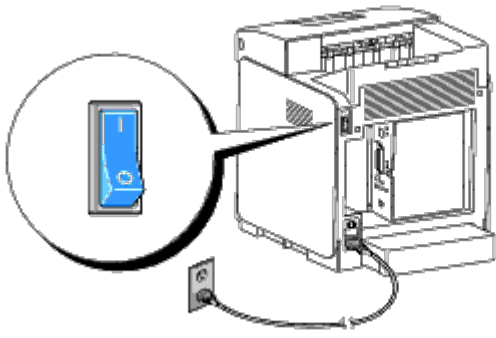

## Connecting the Printer to the Network

To attach the printer to a network:

1. Ensure the printer, computer, and any other attached devices are turned off and unplugged.
2. Connect the printer to the network using an ethernet cable or the wireless printer adapter.

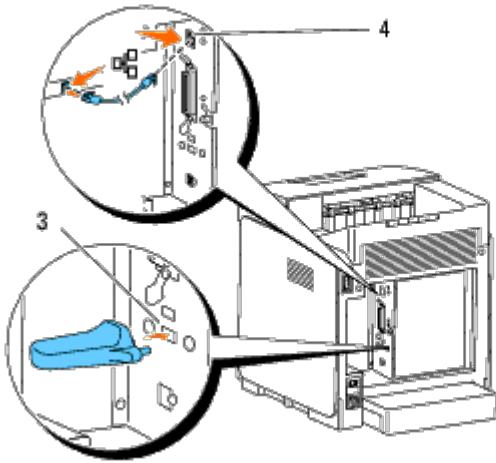

3	Wireless Printer Adapter Socket
4	Ethernet Port

**NOTE:** When the wireless printer adapter is installed, you cannot use the Ethernet port for a wired connection.

To connect the printer to the network, plug one end of an Ethernet cable into the Ethernet port on the back of the printer, and the other end into a LAN drop or hub. For a wireless connection, insert the wireless printer adapter into the wireless printer adapter socket on the back of the printer.

For a wireless connection, refer to ["Installing and Configuring the Wireless Printer Adapter"](#).

## Turn On the Printer

1. Plug one end of the power cable into the socket at the back of the printer and the other end into a properly grounded outlet.

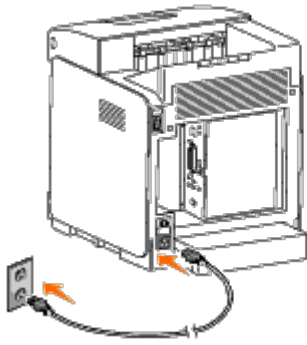

Do not use extension cords or power strips.

The printer should not be plugged into a UPS system.

2. Turn on the computer and the printer.

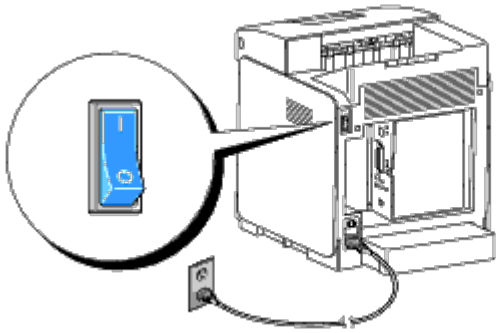

## Print and Check the Printer Settings Page

Print the printer settings page.

### When Using the Operator Panel

1. Press **Menu** button.
2. Ensure *Report/List* appears, and then press **✓ (Set)** button.
3. *Printer Setting* is displayed. Press **✓ (Set)** button.

The printer settings page is printed.

4. If the IP address shows anything other than 0.0.0.0 (the factory default) or 169.254.xx.xx, the printer has an IP address assigned and stored. Go to "[Verify the IP Settings.](#)"

### When Using the Tool Box

1. Click **start® All Programs® Dell Printers® Dell 3130cn Color Laser Printer® Tool Box.**

The **Select Printer** dialog box opens.

2. Click **Dell 3130cn Color Laser PCL 6** listed in **Printer Name**, and then click **OK**.

The **Tool Box** opens.

3. Click the **Printer Settings Report** tab.

4. Select **Reports** from the list at the left side of the page.

The **Reports** page is displayed.

5. Click the **Printer Settings** button.

The printer settings page is printed.

## Assign an IP Address

 **NOTE:** When you assign an IP address manually in **IPv6 Mode**, use the **Dell Printer Configuration Web Tool**. To open the **Dell Printer Configuration Web Tool**, use the link local address. (To check a link local address, see "[Print and Check the Printer Settings Page](#)".)

An IP address is a unique number that consists of four sections that are delimited by a period and can include up to three digits in each section, for example, 111.222.33.44.

Assigning an IP address already in use can cause network performance issues.

 **NOTE:** Assigning an IP address is considered as an advanced function and is normally done by a system administrator.

## When Using the Operator Panel

For more information on using your operator panel, see "[Operator Panel](#)".

1. Turn on the printer.

The Ready to Print appears.

2. Press **Menu** button.

3. Press ▼ button until Admin Menu appears, and then press ✓ (Set) button.

4. Press ▼ button until Network appears, and then press ✓ (Set) button.

5. Press ▼ button until TCP/IP appears, and then press ✓ (Set) button.

6. Press ▼ button until IPv4 appears, and then press ✓ (Set) button.

7. Press ▼ button until IP Address appears, and then press ✓ (Set) button.

8. The cursor is located at the first digit of the IP address. Press ▲ or ▼ button to enter the numbers for the IP address.

9. Press ► button.

The cursor moves to the next digit.

10. Repeat steps 8 and 9 to enter all of the digits in the IP address, and then press ✓ (Set) button.

11. Press ◀ button.

12. Press ▼ button until Subnet Mask appears, and then press ✓ (Set) button.

13. Repeat steps 8 to 9 to set Subnet Mask, and then press ✓ (Set) button.

14. Press ◀ button.

15. Press ▼ button until Gateway Address appears, and then press ✓ (Set) button.

16. Repeat steps 8 to 9 to set Gateway Address, and then press ✓ **(Set)** button.
17. Turn off the printer, and then turn it on again.

## When Using the Tool Box (for IPv4 Mode)

 **NOTE:** When you use **IPv6 Mode** for network printing, you cannot use Tool Box to assign an IP address.

1. Click **start® All Programs® Dell Printers® Dell 3130cn Color Laser Printer® Tool Box**.

The **Select Printer** dialog box opens.

2. Click **Dell 3130cn Color Laser PCL 6** listed in **Printer Name**, and then click **OK**.

The **Tool Box** opens.

3. Click the **Printer Maintenance** tab.
4. Select **TCP/IP Settings** from the list at the left side of the page.

The **TCP/IP Settings** page is displayed.

5. Select the mode from **IP Address Mode**, and then enter the values in IP Address, Subnet Mask, and Gateway Address.
6. Press the **Apply New Settings** button to take effect.

The IP address is assigned to your printer. To verify the setting, open the web browser on any computer connected to the network and enter the IP address into the address bar on the browser. If the IP address is set up correctly, the **Dell Printer Configuration Web Tool** displays in your browser.

You can also assign the IP address to the printer when installing the printer drivers with installer. When you use the **Network Installation** feature, and the Get IP Address is set to AutoIP on the operator panel menu, you can set the IP address from 0.0.0.0 to the desired IP address on the printer selection window.

## Verify the IP Settings

1. Print another printer settings page.
2. Look under the **TCP/IP** heading on the printer settings page to ensure that the IP address, subnetmask, and gateway are what you expected.

or

Ping the printer and verify that it responds. For example, at a command prompt on a network computer, type ping followed by the new IP address (for example, 192.168.0.11):

```
ping 192.168.0.11
```

If the printer is active on the network, you will receive a reply.

---

## Using the Reset Button

Your printer is supplied with an electric leakage detector, which prevents electric shock or fire due to electric leakage by automatically cutting circuits inside the printer.

When electric leakage is detected, the **RESET** button is tripped. In this case, press the **RESET** button to turn the printer back on. If the **RESET** button trips again after pressing the **RESET** button, contact Dell.

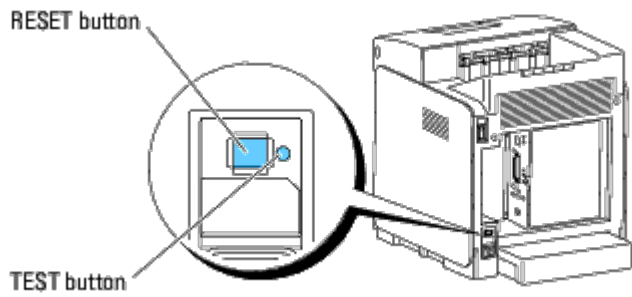

Check whether or not the electric leakage detector is functioning at least once a month by following the steps below:

1. Turn on the printer, and then press the **TEST** button.
  - If the **RESET** button is tripped and the printer is turned off, the electric leakage detector functions correctly. Press the **RESET** button to turn the printer back on.
  - If the **RESET** button is not tripped, contact Dell. Do not continue to use the printer if the electric leakage detector is not functioning.

---

[Back to Contents Page](#)



## Dell Printer Configuration Web Tool

- [Using the Dell Printer Configuration Web Tool](#)
- [Setting Up Your Web Browser](#)
- [Page Display Format](#)
- [Changing the Settings of the Menu Items](#)

 **NOTE:** This web tool is not available unless the printer is connected to a network using a network cable or the wireless printer adapter.

One of the features of the **Dell™ Printer Configuration Web Tool** is E-Mail Alert Setup, which sends an e-mail to you or the key operator when the printer needs supplies or intervention.

To fill out printer inventory reports requiring the asset tag number of all the printers in your area, use the **Printer Information** feature in the **Dell Printer Configuration Web Tool**. Just type the IP address of each printer on the network to display the asset tag number.

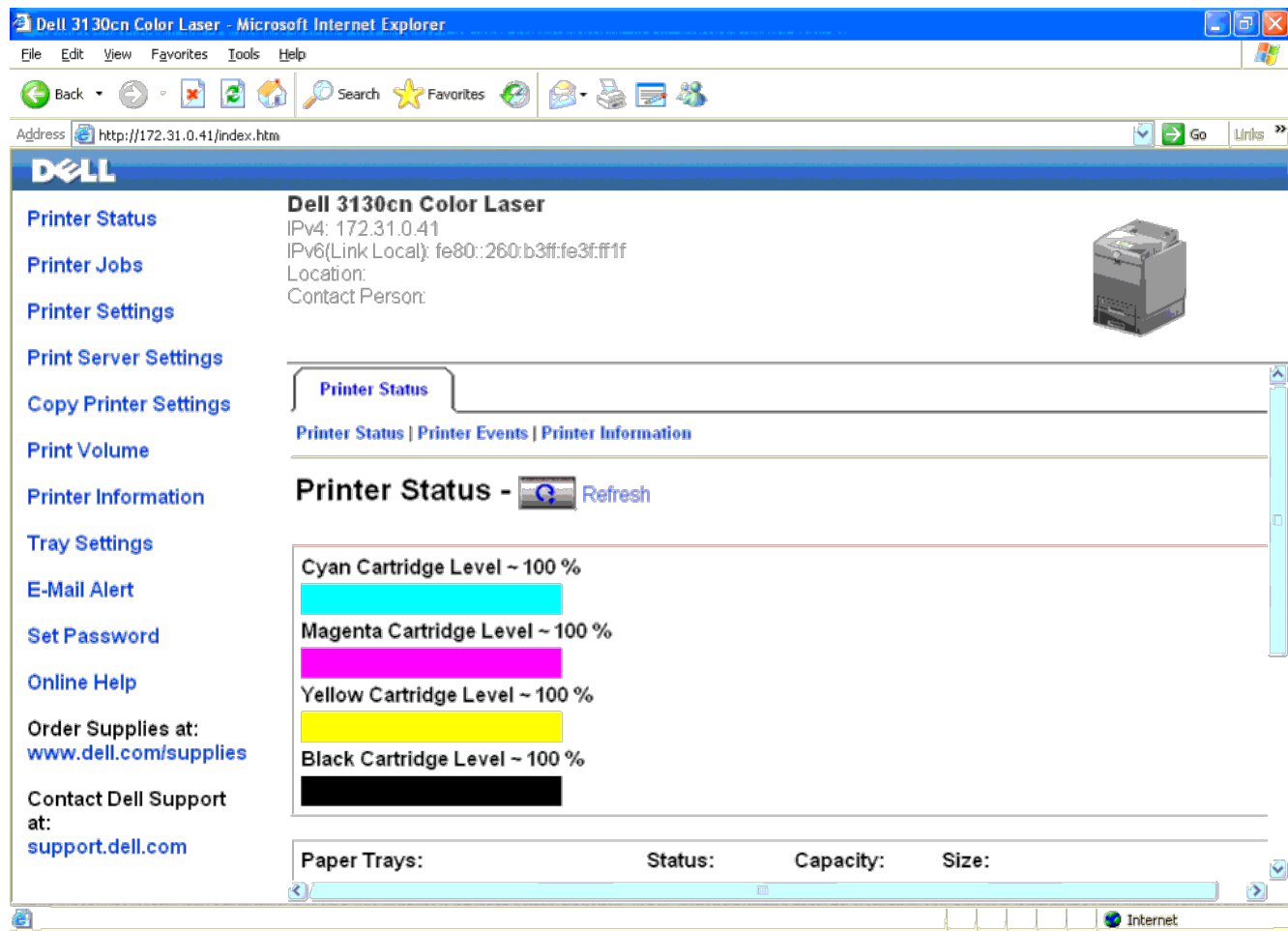

**Dell 3130cn Color Laser**  
IPv4: 172.31.0.41  
IPv6(Link Local): fe80::260:b3ff:fe3f:ff1f  
Location:  
Contact Person:

**Printer Status** - Refresh

Cyan Cartridge Level ~ 100 %  
Magenta Cartridge Level ~ 100 %  
Yellow Cartridge Level ~ 100 %  
Black Cartridge Level ~ 100 %

Paper Trays:	Status:	Capacity:	Size:

The **Dell Printer Configuration Web Tool** feature also allows you to change the printer settings and keep track of printing trends. If you are a network administrator, you can easily copy the printer settings to one or all printers on the network using your Web browser.

To launch the **Dell Printer Configuration Web Tool**, type your printer's IP address in your Web browser.

If you do not know the IP address of your printer, print the printer settings page or display the TCP/IP settings page, which lists the IP address.

### When Using the Operator Panel

1. Press **Menu** button.
2. Press ▼ button until **Report/List** appears, and then press ✓ (**Set**) button.
3. **Printer Setting** is displayed. Press ✓ (**Set**) button.

The printer settings page is printed.

## When Using the Tool Box (for IPv4 Mode)

 **NOTE:** When you use **IPv6 Mode**, use the link local address to open the **Dell Printer Configuration Web Tool**. (To check a link local address, see "[Print and Check the Printer Settings Page](#)".)

1. Click **start**® **All Programs**® **Dell Printers**® **Dell 3130cn Color Laser Printer**® **Tool Box**.

The **Select Printer** dialog box opens.

2. Click **Dell 3130cn Color Laser PCL 6** listed in **Printer Name**, and then click **OK**.

The **Tool Box** opens.

3. Click the **Printer Settings Report** tab.
4. Select **TCP/IP Settings** from the list on the left side of the page.

The **TCP/IP Settings** page is displayed.

If the IP address shows 0.0.0.0 (the factory default), an IP address has not been assigned. To assign one for your printer, see "[Assign an IP Address](#)".

---

## Using the Dell Printer Configuration Web Tool

Use the **Dell Printer Configuration Web Tool** for:

### Printer Status

Use the **Printer Status** menu to get immediate feedback on the printer supply status. When a print cartridge is running low, click the order supplies link on the first screen to order an additional toner cartridge.

### Printer Jobs

Use the **Printer Jobs** menu to contain information on the **Job List** page and **Completed Jobs** page.

These pages show the details of the status regarding each protocol or job.

### Printer Settings

Use the **Printer Settings** menu to change printer settings and view the settings in the operator panel remotely.

### Print Server Settings

Using the **Print Server Settings** menu, you can change the type of printer interface and necessary conditions for communications.

### Copy Printer Settings

Use the **Copy Printer Settings** menu to copy the printer settings to another printer or printers on the network just by typing each printer's IP address.

 **NOTE:** You must log in as an administrator to use this feature.

### Print Volume

Use the **Print Volume** option to check the histories of printing, such as paper usage and types of jobs being printed, and limit which users use the color mode and the maximum number of pages they can print.

## Printer Information

Use the **Printer Information** menu to get the information on service calls, inventory reports, or the status of current memory and engine code levels.

## Tray Settings

Use the **Tray Settings** menu to get the information about the paper type and size for each tray.

## E-Mail Alert

Use the **E-Mail Alert** menu to receive an e-mail when the printer needs supplies or intervention. Type your name or the key operator's name in the e-mail list box to be notified.

## Set Password

Use the **Set Password** menu to lock the **Dell Printer Configuration Web Tool** with a password so that other users do not inadvertently change the printer settings you selected.

 **NOTE:** You must log in as an administrator to use this feature.

## Online Help

Click **Online Help** to visit the Dell Support website.

## Order Supplies at:

[www.dell.com/supplies](http://www.dell.com/supplies)

## Contact Dell Support at:

[support.dell.com](http://support.dell.com)

---

## Setting Up Your Web Browser

Ensure that you activate JavaScript in your browser before using the **Dell Printer Configuration Web Tool**.

It is recommended that you configure the environment settings of your Web browser before using the **Dell Printer Configuration Web Tool**.

 **NOTE:** The Dell Printer Configuration Web Tool pages may be displayed unreadable if the pages were configured by the language different from your web browser's.

## For Internet Explorer® 6.0, Internet Explorer 7.0, Internet Explorer 8.0

### Setting Up the Display Language

1. Select **Internet Options** from **Tools** on the menu bar.
2. Select **Languages** in the **General** tab.
3. Specify the display language in order of preference in the **Language** list.

For example:

- **Italian (Italy) [it-IT]**
- **Spanish (Traditional Sort) [es-ES tradnl]**
- **German (Germany) [de-DE]**
- **French (France) [fr-FR]**
- **English (United States) [en-us]**
- **Danish [da-DK]**

- **Dutch (Netherlands) [nl-NL]**
- **Norwegian (Bokmal) [no]**
- **Swedish [sv-SE]**

## Setting the Printer's IP Address to Non-Proxy

1. Select **Internet Options** from the **Tools** menu.
2. Click **LAN Settings** under **Local Area Network (LAN) Settings** in the **Connections** tab.
3. Do either of the following:
  - Clear the **Use a proxy sever for your LAN** check box under **Proxy server**.
  - Click **Advanced**, and then specify the printer's IP address in the **Do not use proxy server for addresses beginning with** field under **Exceptions**.

After setting the language and proxy, type <http://nnn.nnn.nnn.nnn/> (the printer's IP address) in the URL entry field of the browser to activate the **Dell Printer Configuration Web Tool**.

## For Firefox 2.0 or Later

### Setting Up the Display Language

1. Select **Options** from the **Tools** menu.
2. Click **Advanced**.
3. Click **Choose** in the **General** tab.
4. Specify the display language in order of preference in the **Languages in order of preference** list.

For example:

- **English [en]** or **English/United States [en-us]**
- **Italian [it]**
- **Spanish [es]**
- **German [de]**
- **French [fr]**
- **Dutch [nl]**
- **Norwegian [no]**
- **Swedish [sv]**
- **Danish [da]**

## Setting the Printer's IP Address to Non-Proxy

1. Select **Options** from the **Tools** menu.
2. Click **Advanced** tab.
3. Click **Network** on the **Options** dialog box.
4. Click **Connection® Settings**.
5. Do one of the following:
  - Select the **Direct connection to the Internet** check box.
  - Select the **Auto-detect proxy settings for this network** check box.
  - Select the **Manual proxy configuration** check box, and then enter the printer's IP address in the **No Proxy for** edit box.

Select the **Automatic proxy configuration URL** check box.

After setting the language and proxy, type <http://nnn.nnn.nnn.nnn/> (the printer's IP address) in the URL entry field of the browser to activate the **Dell Printer Configuration Web Tool**.

---

## Page Display Format

The layout of the page is divided into three sections mentioned below:

### Top Frame

The Top Frame is located at the top of all pages. When **Dell Printer Configuration Web Tool** is activated, the current status and specifications of the printer are displayed in the Top Frame on every page.

The following items are displayed in the Top Frame.

<b>Dell 3130cn Color Laser</b>	Displays the printer's product name.
<b>IP Address</b>	Displays the printer's IP address.
<b>Location</b>	Displays the printer's location. The location can be changed in <b>Basic Information</b> on the <b>Print Server Settings</b> page.
<b>Contact Person</b>	Displays the name of the printer's administrator. The name can be changed in the <b>Basic Information</b> on the <b>Print Server Settings</b> page.
<b>Printer Bitmap</b>	Shows the bitmap image of the printer. The <b>Printer Status</b> menu appears in the Right Frame when you click the image.

### Left Frame

The Left Frame is located at the left side of all pages. The menu titles displayed in the Left Frame are linked to corresponding menus and pages. You can go to the corresponding page by clicking their characters.

The following menus are displayed in the Left Frame.

<b>Printer Status</b>	Links to the <b>Printer Status</b> menu.
<b>Printer Jobs</b>	Links to the <b>Printer Jobs</b> menu.
<b>Printer Settings</b>	Links to the <b>Printer Settings Report</b> menu.
<b>Print Server Settings</b>	Links to the <b>Print Server Reports</b> menu.
<b>Copy Printer Settings</b>	Links to the <b>Copy Printer Settings</b> menu.
<b>Print Volume</b>	Links to the <b>Print Volume</b> menu.
<b>Printer Information</b>	Links to the <b>Printer Status</b> menu.
<b>Tray Settings</b>	Links to the <b>Tray Settings</b> menu.
<b>E-Mail Alert</b>	Links to the <b>Print Server Settings</b> menu.
<b>Set Password</b>	Links to the <b>Other Features</b> menu.
<b>Online Help</b>	Links to the Dell Support website.
<b>Order Supplies at:</b>	Links to the Dell web page.
<b>Contact Dell Support at:</b>	Links to the Dell support page web address: <a href="http://support.dell.com/">support.dell.com/</a>

### Right Frame

The Right Frame is located at the right side of all pages. The contents of the Right Frame correspond to the menu that you select in the Left Frame. For details on the items displayed in the Right Frame, see "[Details of the Menu Items](#)".

### Buttons in the Right Frame

<b>Refresh Button</b>	Receives the current printer configuration and updates the latest information in the Right Frame.
<b>Apply New Settings Button</b>	Submits new settings made on the <b>Dell Printer Configuration Web Tool</b> to the printer. The old printer settings will be replaced by the new settings.
<b>Restore Settings Button</b>	Restores the old settings from before changes made. New settings will not be submitted to the printer.

---

## Changing the Settings of the Menu Items

Some menus allow you to change the printer settings through the **Dell Printer Configuration Web Tool**. When you are accessing these menus, the authentication dialog appears on the screen. Type a user name and password for the printer's administrator by following the prompts displayed in the dialog box.

The default user name is **admin**, and the default password is left blank (NULL). You can change only the password in the **Set Password** page in the **Other Features** menu. The user name cannot be changed. See ["Set Password"](#) for more information.

## Details of the Menu Items

"Printer Status"		"Printer Status"		
		"Printer Events"		
		"Printer Information"		
"Printer Jobs"		"Job List"		
		"Completed Jobs"		
"Printer Settings"	"Printer Settings Report"	"Menu Settings"		
		"Reports"		
	"Printer Settings"		"System Settings"	
			"Parallel Settings"	
			"Network Settings"	
			"USB Settings"	
			"PS Settings"	
			"PCL Settings"	
			"Secure Settings"	
	"Printer Maintenance"		"Paper Density"	
			"Adjust BTR"	
			"Adjust Fuser"	
			"Auto Registration Adjustment"	
			"Color Registration Adjustments"	
			"Adjust Altitude"	
			"Reset Defaults"	
			"Storage"*1	
			"Non-Dell Toner"	
			"Initialize PrintMeter"	
		"Web Link Customization"		
	"Print Server Settings"	"Print Server Reports"	"Print Server Setup Page"	
			"NetWare Setup Page"*2	
			"E-Mail Alert Setup Page"	
		"Print Server Settings"		"Basic Information"
				"Port Settings"
				"Wireless LAN"*3
				"TCP/IP"
			"NetWare"*2	
			"SMB"*2	
			"AppleTalk"*2	
			"E-Mail Alert"	
			"Bonjour (mDNS)*2	
			"SNMP"	
"Other Features"			"Set Password"	
			"SSL/TLS"	
		"IPsec"		
		"802.1x"*4		
		"Reset Print Server"		
		"Copy Printer Settings"		

"Copy Printer Settings"	"Copy Printer Settings Report"
"Print Volume"	"Print Volume"
	"Dell ColorTrack"
"Tray Settings"	
*1 This item is only available when the RAM disk is set to on or the optional hard disk is installed.	
*2 An optional network protocol adapter is required to display the item.	
*3 This item is only available when the optional wireless printer adapter is installed.	
*4 This item is only available when the optional wireless printer adapter is not installed.	

## Printer Status

Use the **Printer Status** menu to check the status of consumables, hardware, and specifications of the printer.

The following pages are displayed in the **Printer Status** menu.

### Printer Status

**Purpose:**

To check the status of the consumables and trays.

**Values:**

Cyan Cartridge Level		Displays the percent of toner remaining in each print cartridge. When a cartridge is empty, a message appears. The text <i>Call or Order</i> is linked to the Dell Printer Supplies website.	
Magenta Cartridge Level			
Yellow Cartridge Level			
Black Cartridge Level			
Paper Trays	Status	OK	Indicates that there is some paper in the tray but the quantity is unknown.
		Add Paper	Indicates that there is no paper in the tray.
	Capacity		Displays the maximum capacity of the paper tray.
	Size		Displays the size of paper in the tray.
Output Tray	Status	OK	Indicates that the tray is available.
		Full	Indicates that the tray is not available.
	Capacity		Displays the maximum capacity of the paper tray.
Cover	Status	Closed	Indicates that the cover is closed.
		Open	Indicates that the cover is open.
Printer Type		Displays the type of the printer. <b>Color Laser</b> is displayed normally.	
Printing Speed		Displays the printer's printing speed.	

### Printer Events

**Purpose:**

When faults occur, such as *Out of Paper* or *Front Cover is Open*, the details of all alerts or indications of faults are displayed in the **Printer Events** page.

**Values:**

Location	Displays the location where the error occurred.
Details	Displays the details of the error.

### Printer Information

**Purpose:**

To verify the printer details such as the hardware configuration and software version. This page can also be displayed by clicking **Printer Information** in the Left Frame.

#### Values:

<b>Dell Service Tag Number</b>	Displays Dell's service tag number.	
<b>Asset Tag Number</b>	Displays the printer's asset tag number.	
<b>Printer Serial Number</b>	Displays the printer's serial number.	
<b>Memory Capacity</b>	Displays the memory capacity.	
<b>Hard Disk <sup>*1</sup></b>	Displays information on the printer's hard disk.	
<b>Processor Speed</b>	Displays the processing speed.	
<b>Printer Revision Levels</b>	<b>Firmware Version</b>	Displays the revision date (revision level).
	<b>Network Firmware Version</b>	Displays the revision date (revision level).
*1 This item is only available when the optional hard disk is installed.		

## Printer Jobs

The **Printer Jobs** menu contains information on the **Job List** and **Completed Jobs** pages. These pages show the details of the status regarding each protocol or the print jobs.

### Job List

#### Purpose:

To confirm the print jobs that are being processed. Click the **Refresh** button to update the screen.

#### Values:

<b>ID</b>	Displays the job ID.
<b>Job Name</b>	Displays the file name of the job being printed.
<b>Owner</b>	Displays the job owner's name.
<b>Host Name</b>	Displays the name of the host computer.
<b>Job Status</b>	Displays the status of the job being printed.
<b>Host I/F</b>	Displays the status of the host interface.
<b>Job Submitted Time</b>	Displays the date the print job was submitted.

### Completed Jobs

#### Purpose:

To check the completed jobs. Up to the last 22 print jobs are displayed. Click the **Refresh** button to update the screen.

#### Values:

<b>ID</b>	Displays the job ID.
<b>Job Name</b>	Displays the file name of the job.
<b>Owner</b>	Displays the job owner's name.
<b>Host Name</b>	Displays the name of the host computer.
<b>Output Result</b>	Displays the status of the job.
<b>Impression Number</b>	Displays the job's total number of pages.
<b>No. of Sheets</b>	Displays the job's total number of sheets.
<b>Host I/F</b>	Displays the status of the host interface.
<b>Job Submitted Time</b>	Displays the date the job was submitted.

## Printer Settings

Use the **Printer Settings** menu to display the Printer Settings Report and to configure the printer settings.

The following tabbed pages are displayed at the top of the Right Frame.



## Printer Settings Report

The **Printer Settings Report** tab includes the **Menu Settings** and **Reports** pages.

### Menu Settings

#### Purpose:

To display the current settings of the operator panel menus.

#### Values:

System Settings	<b>Power Saver Timer Mode 1</b>	Displays the time for transition to Power Saver Mode 1.
	<b>Power Saver Timer Mode 2</b>	Displays the time for transition to Power Saver Mode 2.
	<b>Control Panel Tone</b>	Displays whether to emit the tone when the operator panel input is correct. <b>Off</b> indicates that the tone is disabled.
	<b>Invalid Key Tone</b>	Displays whether to emit the tone when the operator panel input is incorrect. <b>Off</b> indicates that the tone is disabled.
	<b>Machine Ready Tone</b>	Displays whether to emit the tone when the printer becomes ready. <b>Off</b> indicates that the tone is disabled.
	<b>Job Completed Tone</b>	Displays whether to emit the tone when a print job is complete. <b>Off</b> indicates that the tone is disabled.
	<b>Fault Tone</b>	Displays whether to emit the tone when a job ends abnormally. <b>Off</b> indicates that the tone is disabled.
	<b>Alert Tone</b>	Displays whether to emit the tone when a problem occurs. <b>Off</b> indicates that the tone is disabled.
	<b>Out of Paper Alert Tone</b>	Displays whether to emit the tone when the printer runs out of paper. <b>Off</b> indicates that the tone is disabled.
	<b>Low Toner Alert Tone</b>	Displays whether to emit the tone when toner or some other consumable is low. <b>Off</b> indicates that the tone is disabled.
	<b>Base Tone</b>	Displays whether to emit the tone when the operator panel screen is returned to the default by scrolling the loop menu. <b>Off</b> indicates that the tone is disabled.
	<b>Fault Time-Out</b>	Displays the amount of time the printer cancels for a job stops abnormally.
	<b>Time-Out</b>	Displays the amount of time the printer waits for data to arrive from the computer.
	<b>Panel Language</b>	Displays the language used on the operator panel screen.
	<b>Auto Log Print</b>	Displays whether to automatically output a log of completed jobs.
	<b>Print ID</b>	Displays where to print a user ID on the output paper.
	<b>Print Text</b>	Displays whether the printer outputs PDL (Page Description Language) data, which is not supported by the printer, as text when the printer receives it.
	<b>Banner Sheet Insert Position</b>	Displays where to insert a banner sheet.
	<b>Banner Sheet Specify Tray</b>	Displays which input tray to use to insert a banner sheet.
	<b>RAM Disk*1</b>	Displays whether to allocate RAM for the file system for the Secure Print and Proof Print features.
<b>Substitute Tray</b>	Displays whether to use another size paper when the paper that is loaded in the specified tray does not match the paper size settings for the current job.	
<b>mm / inch</b>	Displays the measurement unit used on the operator panel screen.	
<b>Odd Page 2 Sided*2</b>	Displays how the odd last page is printed when using duplex printing.	
Parallel Settings	<b>Port Status</b>	Displays whether the parallel interface is enabled.
	<b>ECP</b>	Displays the ECP communication mode of the parallel interface.
	<b>Adobe Protocol</b>	Displays PostScript communication protocol for each interface.
Network Settings	<b>Adobe Protocol</b>	Displays PostScript communication protocol for each interface.
USB Settings	<b>Port Status</b>	Displays whether the USB interface is enabled.
	<b>Adobe Protocol</b>	Displays PostScript communication protocol for each interface.
PCL Settings	<b>Paper Tray</b>	Displays the paper tray setting.
	<b>Paper Size</b>	Displays the paper size setting.
	<b>Custom Size - Y</b>	Displays the length of custom size paper.
	<b>Custom Size - X</b>	Displays the width of custom size paper.
	<b>Orientation</b>	Displays how text and graphics are oriented on the page.
	<b>2 Sided*2</b>	Displays whether to do duplexing as the default for all print jobs.
	<b>Font</b>	Displays the selected font from the list of registered fonts.
	<b>Symbol Set</b>	Displays a symbol set for the specified font.
	<b>Font Size</b>	Displays the font size for scalable typographic fonts.
	<b>Font Pitch</b>	Displays the font pitch for scalable monospaced fonts.
	<b>Form Line</b>	Displays the number of characters in a line.
	<b>Quantity</b>	Displays the number of copies to print.

	<b>Image Enhancement</b>	Displays whether the Image Enhancement feature is enabled.
	<b>Hex Dump</b>	Displays whether the Hex Dump feature is enabled.
	<b>Draft Mode</b>	Displays whether to print in the draft mode.
	<b>Line Termination</b>	Displays whether to set the line termination.
	<b>Default Color</b>	Displays the color mode setting.
<b>PS Settings</b>	<b>PS Error Report</b>	Displays whether the printer outputs error contents for a PostScript error.
	<b>PS Job Time-Out</b>	Displays the execution time for one PostScript job.
	<b>Paper Select Mode</b>	Displays the tray that is selected in the PostScript printing.
	<b>Default Color</b>	Displays the color mode setting.
<b>Secure Settings</b>	<b>Panel Lock Set</b>	Displays whether to lock Admin Menu with a password.
<b>Paper Density</b>	<b>Plain</b>	Displays the paper density of plain paper.
	<b>Label</b>	Displays the paper density of labels.
<b>Adjust BTR</b>	<b>Plain</b>	Displays the voltage setting of the transfer roller (from -3 to 3) for plain paper.
	<b>Plain Thick</b>	Displays the voltage setting of the transfer roller (from -3 to 3) for thick plain paper.
	<b>Transparency</b>	Displays the voltage setting of the transfer roller (from -3 to 3) for transparencies.
	<b>Covers</b>	Displays the voltage setting of the transfer roller (from -3 to 3) for cover paper.
	<b>Covers Thick</b>	Displays the voltage setting of the transfer roller (from -3 to 3) for thick cover paper.
	<b>Label</b>	Displays the voltage setting of the transfer roller (from -3 to 3) for labels.
	<b>Coated</b>	Displays the voltage setting of the transfer roller (from -3 to 3) for coated paper.
	<b>Coated Thick</b>	Displays the voltage setting of the transfer roller (from -3 to 3) for thick coated paper.
	<b>Envelope</b>	Displays the voltage setting of the transfer roller (from -3 to 3) for envelopes.
	<b>Recycled</b>	Displays the voltage setting of the transfer roller (from -3 to 3) for recycled paper.
	<b>JPN Coated</b>	Displays the voltage setting of the transfer roller (from -3 to 3) for Japanese coated paper.
	<b>Postcard JPN</b>	Displays the voltage setting of the transfer roller (from -3 to 3) for Japanese postcards.
<b>Adjust Fuser</b>	<b>Plain</b>	Displays the temperature setting of the fuser (from -2 to 2) for plain paper.
	<b>Plain Thick</b>	Displays the temperature setting of the fuser (from -2 to 2) for thick plain paper.
	<b>Transparency</b>	Displays the temperature setting of the fuser (from -2 to 2) for transparency.
	<b>Covers</b>	Displays the temperature setting of the fuser (from -2 to 2) for cover paper.
	<b>Covers Thick</b>	Displays the temperature setting of the fuser (from -2 to 2) for thick cover paper.
	<b>Label</b>	Displays the temperature setting of the fuser (from -2 to 2) for labels.
	<b>Coated</b>	Displays the temperature setting of the fuser (from -2 to 2) for coated paper.
	<b>Coated Thick</b>	Displays the temperature setting of the fuser (from -2 to 2) for thick coated paper.
	<b>Envelope</b>	Displays the temperature setting of the fuser (from -2 to 2) for envelopes.
	<b>Recycled</b>	Displays the temperature setting of the fuser (from -2 to 2) for recycled paper.
	<b>JPN Coated</b>	Displays the temperature setting of the fuser (from -2 to 2) for Japanese coated paper.
	<b>Postcard JPN</b>	Displays the temperature setting of the fuser (from -2 to 2) for Japanese postcards.
<b>Auto Registration Adjustment</b>		Displays whether to automatically perform color registration adjustment.
<b>Adjust Altitude</b>		Displays the altitude of the location where the printer is installed.
<b>Non-Dell Toner</b>		Displays whether or not to use another manufacturer's toner cartridge.
<b>Web Link Customization</b>	<b>Select Reorder URL</b>	Displays a link used for ordering consumables, which can be accessed from <b>Order Supplies at:</b> in the Left Frame.
	<b>Regular</b>	Displays the regular URL ( <a href="http://accessories.us.dell.com/sna">http://accessories.us.dell.com/sna</a> ) that can be linked to <b>Order Supplies at:</b> .
	<b>Premier</b>	Displays the premier URL ( <a href="http://premier.dell.com">http://premier.dell.com</a> ) that can be linked to <b>Order Supplies at:</b> .
<b>Tray Settings</b>	<b>Tray 1 Paper Type</b>	Displays the paper type setting of the tray 1.
	<b>Tray 1 Paper Size</b>	Displays the paper size setting of the tray 1.
	<b>Tray 1 Custom Size - Y</b>	Displays the length of custom size paper loaded in the tray 1.
	<b>Tray 1 Custom Size - X</b>	Displays the width of custom size paper loaded in the tray 1.
	<b>Tray 2 Paper Type*3</b>	Displays the paper type setting of the tray 2.
	<b>Tray 2 Paper Size*3</b>	Displays the paper size setting of the tray 2.
	<b>Tray 2 Custom Size - Y*3</b>	Displays the length of custom size paper loaded in the tray 2.

<b>Tray 2 Custom Size - X*3</b>	Displays the width of custom size paper loaded in the tray 2.
<b>MPF Mode</b>	Displays the paper size and type when paper is loaded in the multipurpose feeder (MPF).
<b>Display Popup</b>	Displays a popup menu that prompts to set the paper size and type when paper is loaded in the MPF.
<b>MPF Paper Type</b>	Displays the paper type setting of the MPF.
<b>MPF Paper Size</b>	Displays the paper size setting of the MPF.
<b>MPF Custom Size - Y</b>	Displays the length of custom size paper loaded in the MPF.
<b>MPF Custom Size - X</b>	Displays the width of custom size paper loaded in the MPF.

\*1 This item is only available when the 512 MB, or higher, optional memory is installed, and also when the optional hard disk is not installed.

\*2 This item is only available when the optional duplexer is installed.

\*3 This item is only available when the optional 550 sheet feeder is installed.

## Reports

### Purpose:

To print various types of reports and lists.

### Values:

<b>Printer Settings</b>	Click the <b>Start</b> button to print the printer settings page.
<b>Panel Settings</b>	Click the <b>Start</b> button to print the panel settings page.
<b>PCL Fonts List</b>	Click the <b>Start</b> button to print the PCL (Hewlett-Packard Printer Control Language) Fonts List.
<b>PCL Macro List</b>	Click the <b>Start</b> button to print the PCL Macro List.
<b>Job History</b>	Click the <b>Start</b> button to print the Job History report.
<b>Error History</b>	Click the <b>Start</b> button to print the Error History report.
<b>PS Fonts List</b>	Click the <b>Start</b> button to print the PS Fonts List.
<b>Print Meter</b>	Click the <b>Start</b> button to print the Print Meter report.
<b>Color Test Page</b>	Click the <b>Start</b> button to print the Color Test Page.
<b>Stored Documents</b>	Click the <b>Start</b> button to print the Stored Documents list. This item is only available when the 512MB, or higher, optional memory is installed and the RAM Disk is set to on or the optional hard disk is installed.

## Printer Settings

The **Printer Settings** tab includes **System Settings**, **Parallel Settings**, **Network Settings**, **USB Settings**, **PCL Settings**, **PS Settings**, and **Panel Settings** pages.

### System Settings

#### Purpose:

To configure the basic printer settings.

#### Values:

<b>Power Saver Timer Mode 1</b>	Sets the time for transition to Power Saver Mode 1.
<b>Power Saver Timer Mode 2</b>	Sets the time for transition to Power Saver Mode 2.
<b>Control Panel Tone</b>	Specifies whether to enable the tone that is emitted when the operator panel input is correct.
<b>Invalid Key Tone</b>	Specifies whether to enable the tone that is emitted when the operator panel input is incorrect.
<b>Machine Ready Tone</b>	Specifies whether to enable the tone that is emitted when the printer becomes ready.
<b>Job Completed Tone</b>	Specifies whether to enable the tone that is emitted when a print job is complete.
<b>Fault Tone</b>	Specifies whether to enable the tone that is emitted when a job ends abnormally.
<b>Alert Tone</b>	Specifies whether to enable the tone that is emitted when a problem occurs.
<b>Out of Paper Alert Tone</b>	Specifies whether to enable the tone that is emitted when the printer runs out of paper.
<b>Low Toner Alert Tone</b>	Specifies whether to enable the tone that is emitted when toner or some other consumable is low.
<b>Base Tone</b>	Specifies whether to enable the tone that is emitted when the operator panel screen returns to the default by scrolling the loop menu.
<b>Fault Time-Out</b>	Specifies in seconds the amount of time the printer should cancel for a job stops abnormally. The print job is cancelled if the time-out time is exceeded.

<b>Time-Out</b>	Specifies in seconds the amount of time the printer should wait for data to arrive from the computer. The print job is cancelled if the time-out time is exceeded.
<b>Panel Language</b>	Sets the language to be used on the operator panel.
<b>Auto Log Print</b>	Specifies whether to automatically print a log of completed jobs after every 20 jobs.
<b>Print ID</b>	Specifies where to print the user ID on the output paper.
<b>Print Text</b>	Specifies whether the printer outputs PDL data, which is not supported by the printer, as text when the printer receives it.
<b>Banner Sheet Insert Position</b>	Specifies where to insert a banner sheet.
<b>Banner Sheet Specify Tray</b>	Specifies which input tray to use to insert a banner sheet.
<b>RAM Disk</b>	Specifies whether to allocate RAM for the file system for the Secure Print and Store Print features. This item is only available when the 512 MB, or higher, optional memory is installed, and also when the optional hard disk is not installed.
<b>Substitute Tray</b>	Specifies whether or not to use another size paper when the paper that is loaded in the specified tray does not match the paper size settings for the current job.
<b>mm / inch</b>	Specifies the measurement unit to be used on the operator panel screen as either mm or inches.
<b>Odd Page 2 Sided</b>	Specifies how the odd last page is printed when using duplex printing. This item is only available when the optional duplexer is installed.

### Parallel Settings

**Purpose:**

To configure the parallel interface.

**Values:**

<b>Port Status</b>	Specifies whether to enable the parallel interface.
<b>ECP</b>	Specifies whether to enable the ECP communication mode of the parallel interface.
<b>Adobe Protocol</b>	Specifies PostScript communication protocol for each interface.

### Network Settings

**Purpose:**

To Specify the PostScript communication protocol for this printer.

**Values:**

<b>Adobe Protocol</b>	Specifies PostScript communication protocol for each interface.
-----------------------	-----------------------------------------------------------------

### USB Settings

**Purpose:**

To change printer settings affecting a USB port.

**Values:**

<b>Port Status</b>	Specifies whether to enable the USB interface.
<b>Adobe Protocol</b>	Specifies PostScript communication protocol for each interface.

### PCL Settings

**Purpose:**

To change the printer settings that only affect jobs using the PCL emulation printer language.

**Values:**

<b>Paper Tray</b>	Specifies the input tray.
<b>Paper Size</b>	Specifies the paper size.
<b>Custom Size - Y</b>	Specifies the length of custom size paper.
<b>Custom Size - X</b>	Specifies the width of custom size paper.
<b>Orientation</b>	Specifies how text and graphics are oriented on the page.

<b>2 Sided</b>	Sets duplexing as the default for all print jobs. This item is only available when the optional duplexer is installed.
<b>Font</b>	Specifies the font from the list of registered fonts.
<b>Symbol Set</b>	Specifies a symbol set for the specified font.
<b>Font Size</b>	Specifies the font size for scalable typographic fonts.
<b>Font Pitch</b>	Specifies the font pitch for scalable monospaced fonts.
<b>Form Line</b>	Specifies the number of characters in a line.
<b>Quantity</b>	Sets the number of copies to print.
<b>Image Enhancement</b>	Specifies whether to enable the Image Enhancement feature.
<b>Hex Dump</b>	Specifies whether to help isolate the source of a print job problem. With Hex Dump selected, all data sent to the printer is printed in hexadecimal and character representation. Control codes are not executed.
<b>Draft Mode</b>	Specifies whether to print in the draft mode.
<b>Line Termination</b>	Specifies how to handle line terminations.
<b>Default Color</b>	Specifies the print color mode to <b>Color</b> or <b>Black</b> . This setting is used for print jobs without a specified color print mode.

## PS Settings

### Purpose:

To change printer settings that only affect jobs using the PostScript emulation printer language.

### Values:

<b>PS Error Report</b>	Specifies whether the printer outputs error contents for a PostScript error.
<b>PS Job Time-Out</b>	Specifies the execution time for one PostScript job.
<b>Init PS Disk</b>	Erases the PS fonts stored on the optional hard disk. This item is only available when the optional hard disk is installed.
<b>Paper Select Mode</b>	Specifies the way to select the tray for the PostScript mode.
<b>Default Color</b>	Specifies the default color mode for the PostScript mode.

## Secure Settings

### Panel Lock Set

#### Purpose:

To set whether to lock Admin Menu with a password, and to set or change the password.

#### Values:

<b>Panel Lock Set</b>	Sets whether to lock Admin Menu with a password.
<b>New Password</b>	Sets a password that is required to access Admin Menu.
<b>Re-enter Password</b>	Enter the new password again to confirm.



**NOTE:** This menu sets a password to lock the operator panel. When changing the password for the **Dell Printer Configuration Web Tool**, click **Set Password** on the Left Frame and set the password.

## Printer Maintenance

The **Printer Maintenance** tab includes **Paper Density**, **Adjust BTR**, **Adjust Fuser**, **Auto Registration Adjustment**, **Color Registration Adjustments**, **Adjust Altitude**, **Reset Defaults**, **Non-Dell Toner**, **Initialize PrintMeter**, **Storage**, and **Web Link Customization** pages.

### Paper Density

#### Purpose:

To specify the paper density.

#### Values:

<b>Plain</b>	Sets the density of plain paper to <b>Light</b> or <b>Normal</b> .
<b>Label</b>	Sets the density of labels to <b>Light</b> or <b>Normal</b> .

### Adjust BTR

**Purpose:**

To specify the reference voltage settings for the transfer roller.

**Values:**

<b>Plain</b>	Sets the reference voltage setting for the transfer roller for plain paper within the range of -3 to 3.
<b>Plain Thick</b>	Sets the reference voltage setting for the transfer roller for thick plain paper within the range of -3 to 3.
<b>Transparency</b>	Sets the reference voltage setting for the transfer roller for transparencies within the range of -3 to 3.
<b>Covers</b>	Sets the reference voltage setting for the transfer roller for cover paper within the range of -3 to 3.
<b>Covers Thick</b>	Sets the reference voltage setting for the transfer roller for thick cover paper within the range of -3 to 3.
<b>Label</b>	Sets the reference voltage setting for the transfer roller for labels within the range of -3 to 3.
<b>Coated</b>	Sets the reference voltage setting for the transfer roller for coated paper within the range of -3 to 3.
<b>Coated Thick</b>	Sets the reference voltage setting for the transfer roller for thick coated paper within the range of -3 to 3.
<b>Envelope</b>	Sets the reference voltage setting for the transfer roller for envelopes within the range of -3 to 3.
<b>Recycled</b>	Sets the reference voltage setting for the transfer roller for recycled paper within the range of -3 to 3.
<b>JPN Coated</b>	Sets the reference voltage setting for the transfer roller for Japanese coated paper within the range of -3 to 3.
<b>Postcard JPN</b>	Sets the reference voltage setting for the transfer roller for Japanese postcards within the range of -3 to 3.

**Adjust Fuser****Purpose:**

To specify the temperature settings value for the fuser.

**Values:**

<b>Plain</b>	Sets the temperature settings for the fuser for plain paper within the range of -2 to 2.
<b>Plain Thick</b>	Sets the temperature settings for the fuser for thick plain paper within the range of -2 to 2.
<b>Transparency</b>	Sets the temperature settings for the fuser for transparencies within the range of -2 to 2.
<b>Covers</b>	Sets the temperature settings for the fuser for cover paper within the range of -2 to 2.
<b>Covers Thick</b>	Sets the temperature settings for the fuser for thick cover paper within the range of -2 to 2.
<b>Label</b>	Sets the temperature settings for the fuser for labels within the range of -2 to 2.
<b>Coated</b>	Sets the temperature settings for the fuser for coated paper within the range of -2 to 2.
<b>Coated Thick</b>	Sets the temperature settings for the fuser for thick coated paper within the range of -2 to 2.
<b>Envelope</b>	Sets the temperature settings for the fuser for envelopes within the range of -2 to 2.
<b>Recycled</b>	Sets the temperature settings for the fuser for recycled paper within the range of -2 to 2.
<b>JPN Coated</b>	Sets the temperature settings for the fuser for Japanese coated paper within the range of -2 to 2.
<b>Postcard JPN</b>	Sets the temperature settings for the fuser for Japanese postcards within the range of -2 to 2.

**Auto Registration Adjustment****Purpose:**

To specify whether to automatically perform color registration adjustment.

**Color Registration Adjustments****Purpose:**

To specify whether to manually perform color registration adjustment.  
Manual Color Registration Adjustments are required such as when the printer is initially installed and after the printer is moved.

 **NOTE:** The **Color Registration Adjustments** feature can be configured when **Auto Registration Adjustment** is set to **Off**.

**Values:**

<b>Auto Correct</b>	Click <b>Start</b> to Automatically performs color registration correction.
---------------------	-----------------------------------------------------------------------------

<b>Color Regi Chart</b>	Click <b>Start</b> to print a color registration chart. The color registration chart prints a lattice pattern of yellow, magenta, and cyan lines. On the chart, find the values on the right side that are next to the straightest lines for each of the three colors. If the value for the straightest line is 0, color registration adjustment is not required. If the value for the straightest line is any value other than 0, specify the adjustment values under <b>Color Registration Adjustments</b> .
<b>Enter Number</b>	Specifies lateral (perpendicular to paper feed direction) color adjustment values individually for Yellow, Magenta, and Cyan.

### Adjust Altitude

**Purpose:**

To specify the altitude of the location where the printer is installed.

The discharge phenomenon for charging the photo conductor varies with barometric pressure. Adjustments are performed by specifying the altitude of the location where the printer is being used.

### Reset Defaults

**Purpose:**

To initialize the NV (non-volatile) memory. After executing this function to automatically restart the printer and rebooting the printer, all the menu parameters are reset to their default values.

### Non-Dell Toner

**Purpose:**

To specify whether or not to use another manufacturer's print cartridge.



**NOTE:** Before you use another manufacture's print cartridge, be sure to restart the printer.



**NOTICE:** Use of a non-Dell print cartridge may result in some of the printer's functions to be unavailable, a reduction in print quality, or deterioration of printer's reliability. Use of a new Dell brand print cartridge is recommended for your printer. The Dell warranty does not cover any problems caused by the use of any accessory, part, or component that is not supplied by Dell.

### Initialize PrintMeter

**Purpose:**

To initialize the print meter of the printer. When the print meter is initialized, the meter count is reset to 0.

### Storage

**Purpose:**

To clear all files stored in the RAM Disk or the optional hard disk, or format the optional hard disk.

**Values:**

<b>Clear Storage</b>	Click Start to clear all files that are stored as Secure and Proof Print in the RAM disk or the optional hard disk. This item is only available when the RAM disk is set to on or the optional hard disk is installed.
<b>Format HDD</b>	Click Start to format the optional hard disk. All fonts, forms and files for Secure Print and Proof Print stored in the optional hard disk are cleared. The data relating to PostScript isn't cleared. To clear the data relating to Post Script, refer to <a href="#">"Init PS Disk"</a> . This item is only available when the optional hard disk is installed.

### Web Link Customization

**Purpose:**

To specify a link used for ordering consumables, which can be accessed from **Order Supplies at:** in the Left Frame.

**Values:**

<b>Select Reorder URL</b>	Select the regular or premier URL to be linked to <b>Order Supplies at:</b> .
<b>Regular</b>	Displays the regular URL ( <a href="http://accessories.us.dell.com/sna">http://accessories.us.dell.com/sna</a> ) that can be linked to <b>Order Supplies at:</b> .
<b>Premier</b>	Displays the premier URL ( <a href="http://premier.dell.com">http://premier.dell.com</a> ) that can be linked to <b>Order Supplies at:</b> .

## Print Server Settings

Use the **Print Server Settings** menu to set the type of printer interface and necessary conditions for communications.

The following tabbed pages are displayed in the top of the Right Frame.

### Print Server Reports

The **Print Server Reports** tab includes **Print Server Setup Page**, **Netware Setup Page**, and **E-Mail Alert Setup Page**.

### Print Server Setup Page

#### Purpose:

To verify the current settings of TCP/IP (Transmission Control Protocol/Internet Protocol) and printing ports. On this page, you can only verify the settings of items. If you want to change the settings, go to the pages in the **Print Server Settings** tab.

#### Values:

Ethernet *1	<b>Ethernet Settings</b>		Displays the current settings of Ethernet transmission rate and the duplex settings.	
	<b>Current Ethernet Settings</b>		Displays the current Ethernet settings.	
	<b>MAC Address</b>		Displays the printer's MAC address.	
Wireless Settings *2	<b>SSID</b>		Displays the name that identifies the network.	
	<b>Network Type</b>		Displays the network type from either the Ad-Hoc or Infrastructure mode.	
	<b>MAC Address</b>		Displays the MAC address of the wireless printer adapter.	
	<b>Link Channel</b>		Displays the channel number of the connection.	
	<b>Link Quality</b>		Displays the quality of the connection.	
TCP/IP Settings	<b>IP Mode</b>		Displays the IP mode.	
	<b>Host Name</b>		Displays the host name.	
	IPv4	<b>IP Address Mode</b>		Displays the IP address mode.
		<b>IP Address</b>		Displays the IP address.
		<b>Subnet Mask</b>		Displays the subnet mask.
		<b>Gateway Address</b>		Displays the gateway address.
	IPv6	<b>Use Manual Address</b>		Displays whether to set the IP address manually.
		<b>Manual Address</b>		Displays the IP address.
		<b>Stateless Address 1-3</b>		Displays the stateless addresses.
		<b>Link Local Address</b>		Displays the link local address.
		<b>Manual Gateway Address</b>		Displays the gateway address.
<b>Auto Configure Gateway Address</b>		Displays the gateway address.		
DNS	IPv4	<b>Get DNS Server Address from DHCP</b>		Displays whether to automatically get a DNS (Domain Name System) server address from the DHCP (Dynamic Host Configuration Protocol) server.
		<b>Current DNS Server Address</b>		Displays the DNS server address.
	IPv6	<b>Get DNS Server Address from DHCPv6-lite</b>		Displays whether to automatically get a DNS server address from the DHCPv6-lite server.
		<b>Current DNS Server Address</b>		Displays the DNS server address.
	<b>DNS Dynamic Update (IPv4) *3</b>		Displays the status of the DNS Dynamic Update feature.	
	<b>DNS Dynamic Update (IPv6) *3</b>		Displays the status of the DNS Dynamic Update feature.	
	<b>Auto Generate Search List *3</b>		Displays whether to automatically generate a search list.	
	<b>Search Domain Name *3</b>		Displays the search domain name.	
<b>Time-out *3</b>		Displays the time-out period.		
<b>Priority to IPv6 DNS Name Resolution *4</b>		Displays whether to use the DNS Name Resolution feature.		
WINS *3	<b>WINS Mode</b>		Displays the setting of how to get the WINS server address.	
	<b>WINS Primary Server</b>		Displays the primary WINS server address.	
	<b>WINS Secondary Server</b>		Displays the secondary WINS server address.	



LPD	Port Status	Displays the port status.
	Connection Time-Out	Displays the connection timeout period.
Port9100	Port Status	Displays the port status.
	Port Number	Displays the port number.
	Connection Time-Out	Displays the connection timeout period.
IPP <sup>*3</sup>	Port Status	Displays the port status.
	Printer URI	Displays the printer URI.
	Connection Time-Out	Displays the connection timeout period.
	Port Number	Displays the port number.
WSD	Maximum Sessions	Displays the maximum number of connections received simultaneously by the client.
	Port Status	Displays the WSD port status.
	Port Number	Displays the WSD port number.
	Receive Time-Out	Displays the receive timeout period.
	Notification Time-Out	Displays the notification timeout period.
HTTP	Maximum Number of TTL	Displays the maximum number of TTLs.
	Maximum Number of Notification	Displays the maximum number of notifications.
	Port Status	Displays the port status.
	Port Number	Displays the port number.
	Simultaneous Connections	Displays the number of connections received simultaneously by the client.
SMB <sup>*3</sup>	Connection Time-Out	Displays the connection timeout period.
	Port Status	Displays the port status.
	Host Name	Displays the host name.
	Workgroup	Displays the workgroup name.
	Maximum Sessions	Displays the maximum number of connections received simultaneously by the client.
	Unicode Support	Displays the status of the <b>Unicode Support</b> feature.
	Auto Master Mode	Displays the status of the <b>Auto Master Mode</b> feature.
	Encrypt Password	Displays the status of the <b>Encrypt Password</b> feature.
AppleTalk <sup>*3</sup>	Job Time-Out	Displays the timeout period.
	Connection Time-Out	Displays the connection timeout period.
	Port Status	Displays the port status.
	Printer	Displays the printer name used in AppleTalk.
	AppleTalk Zone	Displays the AppleTalk zone name.
Bonjour (mDNS) <sup>*3</sup>	AppleTalk Type	Displays the AppleTalk type.
	Delay Start Time	Specifies the print start time period in second.
	Port Status	Displays the port status.
SNMP	Host Name	Displays the host name.
	Printer Name	Displays the printer name.
	Port Status	Displays the port status.
Telnet	Enable SNMP v1/v2c Protocol	Displays the status of the <b>SNMP v1/v2c</b> feature.
	Enable SNMP v3 Protocol	Displays the status of the <b>SNMP v3</b> feature.
	Port Status	Displays the port status.
SSL/TLS	Connection Time-Out	Displays the connection timeout period.
	HTTPS	Displays the HTTPS status.
IPsec Settings	Port Number	Displays the port number.
	Protocol	Displays the protocol status.
	IKE	Displays to use a preshared key for IKE authentication.
	IKE SA Lifetime	Displays the lifetime for IKE SA.
	IPsec SA Lifetime	Displays the lifetime for IPsec SA.
	DH Group	Displays the DH group.

	<b>PFS</b>	Displays the PFS status.
	<b>Remote peers IPv4 address</b>	Displays the IP address to connect to.
	<b>Remote peers IPv6 address</b>	Displays the IP address to connect to.
	<b>Non IPsec communication policy</b>	Displays the status of the <b>Non IPsec communication policy</b> feature.
<b>802.1x</b> *1*3	<b>Enable IEEE 802.1x</b>	Displays the status of IEEE 802.1x.
	<b>Authentication Method</b>	Displays the setting of authentication method for IEEE 802.1x.
<b>IP Filter (IPv4)</b> *5	<b>Access List</b>	Displays the list of IP addresses that are permitted or denied access to the printer.

\*1 This settings are not displayed when the optional wireless printer adapter is installed.

\*2 An optional wireless printer adapter is required to display the item.

\*3 An optional network protocol adapter is required to display the item.

\*4 This item is only available when using IPv6 dual mode.

\*5 This item is only available for LPD or Port9100.

## NetWare Setup Page

### Purpose:

To verify the current settings of IPX/SPX and Netware. In this page, you can only verify the settings of items. If you want to change the settings, go to the pages in the **Print Server Settings** tab.

### Values:

<b>IPX/SPX Settings</b>	<b>Frame Type</b>	Displays the active frame type.
	<b>Current Frame Type</b>	Displays the current frame type.
	<b>Network Address</b>	Displays the IPX network address.
<b>NetWare</b>	<b>Port Status</b>	Displays the port status. When NetWare is implemented, the status of IPX/SPX and TCP/IP is also displayed.
	<b>Device Name</b>	Displays the printer name.
	<b>Active Mode</b>	Displays the current mode for Active Mode.
	<b>Tree Name</b>	Displays the tree name.
	<b>Context Name</b>	Displays the context name of the Print Server Object.
	<b>File Server Name</b>	Displays the file server name.
	<b>Polling Interval</b>	Displays the time interval.
	<b>NCP Packet Burst</b>	Displays the status, and whether to use NCP packet burst.
	<b>Status Information</b>	Displays messages according to the conditions of the printer.
<b>SLP</b>	<b>Active Discovery</b>	Displays whether active discovery is enabled.

 **NOTE:** An optional network protocol adapter is required to display the **NetWare Setup** page.

## E-Mail Alert Setup Page

### Purpose:

To verify the current settings of SMTP/POP (Simple Mail Transfer Protocol/Post Office Protocol) used for the e-mail feature and E-Mail Alerts feature. In this page, you can only verify the settings of items. If you want to change the settings, go to the pages in the **Print Server Settings** tab.

### Values:

<b>E-Mail Server Settings</b>	<b>Port Status</b>	Displays the port status.
	<b>Primary SMTP Gateway</b>	Displays the primary SMTP (Simple Mail Transfer Protocol) gateway.
	<b>SMTP Port Number</b>	Displays the SMTP port number.
	<b>E-Mail Send Authentication</b>	Displays the authentication method for outgoing e-mail.
	<b>POP3 Server Address</b>	Displays the POP3 (Post Office Protocol 3) server address.
	<b>POP3 Port Number</b>	Displays the POP3 port number.
	<b>Reply Address</b>	Displays the IP address of servers connected with SMTP protocol when data is incoming.
	<b>SMTP Server Connection</b>	Displays the status of the SMTP server connection.
	<b>E-Mail List 1</b>	Displays the acceptable e-mail addresses for the E-Mail Alert feature specified in <b>E-mail List 1</b> .

E-Mail Alert Settings	Select Alerts for List 1	Supplies Alerts	Displays the status, and whether to receive an E-Mail Alert, for consumables.
		Paper Handling Alerts	Displays the status, and whether to receive an E-Mail Alert, for paper handling.
		Service Call	Displays the status, and whether to receive an E-Mail Alert, for Service Calls.
	E-Mail List 2	Displays the acceptable e-mail addresses for the E-Mail Alert feature specified in <b>E-mail List 2</b> .	
	Select Alerts for List 2	Supplies Alerts	Displays the status, and whether to receive an E-Mail Alert, for consumables.
		Paper Handling Alerts	Displays the status, and whether to receive an E-Mail Alert, for paper handling.
Service Call		Displays the status, and whether to receive an E-Mail Alert, for Service Calls.	

## Print Server Settings

The **Print Server Settings** tab includes **Basic Information**, **Port Settings**, **Wireless LAN**, **TCP/IP**, **NetWare**, **SMB**, **AppleTalk**, **E-Mail Alert**, **Bonjour(mDNS)**, and **SNMP** pages.

### Basic Information

#### Purpose:

To configure the printer's basic information.

#### Values:

System Settings	Printer Name	Specifies the name of the printer using up to 31 alphanumeric characters.
	Location	Specifies the location of the printer using up to 63 alphanumeric characters.
	Contact Person	Specifies the contact name, number, and other information of the printer's administrator and service center using up to 63 alphanumeric characters.
	Administrator E-Mail Address	Specifies the contact address of the printer's administrator and service center using up to 63 alphanumeric characters.
	Asset Tag Number	Enter the asset tag number for the printer.
EWS Settings	Auto Refresh	Sets whether or not to automatically refresh the contents of the status display pages.
	Auto Refresh Interval	Sets the time interval for refreshing the contents of the status display pages automatically from 15 to 600 seconds.

 **NOTE:** The **Auto Refresh** feature is effective for the contents of the Top Frame, **Printer Status** page, **Job List** page, and **Completed Jobs** page.

### Port Settings

#### Purpose:

To specify whether to enable or disable printing ports and management protocol features.

#### Values:

Ethernet *1	Ethernet Settings	Auto	Detects Ethernet transmission rate and the duplex settings automatically.
		10BASE-T Half-Duplex	Selects 10Base-T Half-Duplex as the default value.
		10BASE-T Full-Duplex	Selects 10Base-T Full-Duplex as the default value.
		100BASE-TX Half-Duplex	Selects 100Base-T Half-Duplex as the default value.
		100BASE-TX Full-Duplex	Selects 100Base-T Full-Duplex as the default value.
	Current Ethernet Settings	Displays the current settings of Ethernet.	
Port Status	MAC Address	Displays the printer's MAC address.	
	LPD	Select the check box to enable LPD.	
	Port9100	Select the check box to enable Port9100.	
	IPP *2	Select the check box to enable the IPP port.	
	WSD	Select the check box to enable the WSD port.	
	SMB *2	Select the check box to enable the SMB. You can also configure the transport protocol to be used. TCP/IP and NetBEUI can be selected simultaneously as the transport protocol.	
	NetWare *2	Select the check box to enable the NetWare port. You can also configure the transport protocol to be used. IPX/SPX and TCP/IP can be selected simultaneously as the transport protocol.	
	AppleTalk *2	Select the check box to enable the AppleTalk port.	
	Bonjour (mDNS) *2	Select the check box to enable the Bonjour(mDNS) feature.	

<b>E-Mail Alert</b>	Select the check box to enable the <b>E-Mail Alert</b> feature.
<b>SNMP</b>	Select the check box to enable the SNMP (Simple Network Management Protocol). You can also configure the transport protocol to be used. UDP and IPX can be selected simultaneously as the transport protocol. IPX is only available when the optional network protocol adapter is installed.
*1 The <b>Ethernet</b> settings are not displayed when the optional wireless printer adapter is installed.	
*2 An optional network protocol adapter is required to display the item.	

 **NOTE:** The settings in the **Port Settings** page will be valid only when the printer is rebooted. When you change or configure the settings, click the **Apply new settings** button to apply new settings.

## Wireless LAN

### Purpose:

To configure the detailed setting for the wireless network.

### Values:

<b>Wireless Settings</b>	<b>SSID</b>	Specifies the name that identifies the wireless network. Up to 32 alphanumeric characters.
	<b>Network Type</b>	Specifies the network type from either <b>Ad-Hoc</b> or <b>Infrastructure</b> .
	<b>MAC Address</b>	Displays the MAC address of the printer's wireless network adapter.
	<b>Link Channel</b>	Displays the channel number of the printer's wireless connection.
	<b>Link Quality</b>	Displays the quality of the printer's wireless network connection.
<b>Security Settings</b>	<b>Encryption</b>	Select the security method from the list.
	<b>WEP Key Code</b>	Select the WEP key code from either <b>Hex</b> or <b>Ascii</b> .
	<b>WEP Key (Password)</b>	Specifies the WEP key set used through the wireless network only when <b>WEP 128bit</b> or <b>WEP 64bit</b> is selected for <b>Encryption</b> .
	<b>Re-enter WEP Key</b>	Enter the WEP key again to confirm it.
	<b>Transmit Key (Index)</b>	Specifies the transmit key from the list.
	<b>Pass Phrase (Password)</b>	Specifies the pass phrase from 8 to 63 alphanumeric characters only when <b>WPA-PSK AES</b> , <b>WPA2-PSK AES</b> or <b>WPA-PSK TKIP</b> is selected for <b>Encryption</b> .
	<b>Re-enter Pass Phrase</b>	Enter the pass phrase again to confirm it.

 **NOTE:** An optional wireless printer adapter is required to display the **Wireless** page.

## TCP/IP

### Purpose:

To configure the IP address, subnet mask, and gateway address of the printer.

### Values:

<b>TCP/IP Settings</b>	<b>IP Mode</b>	Specifies the IP mode.		
	<b>Host Name</b>	Specifies the host name.		
	<b>IPv4</b>	<b>IP Address Mode</b>	Selects the IP address mode.	
		<b>Manual IP Address</b>	Sets the IP address.	
		<b>Manual Subnet Mask</b>	Sets the subnet mask.	
	<b>IPv6</b>	<b>Manual Gateway Address</b>	Sets the gateway address.	
		<b>Use Manual Address</b>	Select the check box to set the IP address manually.	
<b>Manual Address</b>		Sets the IP address. To specify an IPv6 address, enter the address followed by a slash (/) and then "64". For details, consult your system administrator.		
<b>DNS</b>	<b>Manual Gateway Address</b>	Sets the gateway address.		
	<b>DNS Domain Name</b>	Specifies the domain name of the domain name server. Up to 255 alphanumeric characters, periods, and hyphens can be used. If you need to specify more than one domain name, separate them using a comma or semicolon.		
	<b>IPv4</b>	<b>Get DNS Server Address from DHCP</b>	Select the check box to get the DNS server address automatically from the DHCP server.	
		<b>Manual DNS Server Address</b>	Sets the DNS server address.	
	<b>IPv6</b>	<b>Get DNS Server Address from DHCPv6-lite</b>	Select the check box to get the DNS server address automatically from the DHCPv6-lite server.	
<b>Manual DNS Server Address</b>		Sets the DNS server address.		
	<b>DNS Dynamic Update (IPv4) *1</b>	Select the check box to enable dynamic updates to DNS.		

	<b>DNS Dynamic Update (IPv6)*<sup>1</sup></b>	Select the check box to enable dynamic updates to DNS.
	<b>Auto Generate Search List*<sup>1</sup></b>	Select the check box to automatically generate the search list.
	<b>Search Domain Name*<sup>1</sup></b>	Specifies the search domain name. Up to 255 alphanumeric characters, periods, and hyphens can be used. If you need to specify more than one domain name, separate them using a comma or semicolon.
	<b>Time-out*<sup>1</sup></b>	Specifies the time-out period between 1 and 60 seconds.
	<b>Priority to IPv6 DNS Name Resolution</b>	Select the check box to enable the DNS Name Resolution feature.
<b>WINS*<sup>1</sup></b>	<b>WINS Mode</b>	Select the check box to get the WINS server address automatically from the DHCP server.
	<b>WINS Primary Server</b>	Sets WINS server address in the <i>nnn.nnn.nnn.nnn</i> format. Each section of <i>nnn.nnn.nnn.nnn</i> is a value between 0 and 254. Note that values 127 and 224 to 254 are not valid for the first three-digits.
	<b>WINS Secondary Server</b>	Sets a back up WINS server address in the <i>nnn.nnn.nnn.nnn</i> format. Each section of <i>nnn.nnn.nnn.nnn</i> is a value between 0 and 254. Note that values 127 and 224 to 254 are not valid for the first three-digits.
<b>LPD</b>	<b>Connection Time-Out</b>	Sets the connection timeout period from 1 to 1000 seconds.
	<b>IP Filter (IPv4)</b>	To set the IP Filter settings, click <b>IP Filter (IPv4)</b> . The <b>IP Filter (IPv4)</b> page is displayed.
<b>Port9100</b>	<b>Port Number</b>	Sets the port number from 9000 to 9999.
	<b>Connection Time-Out</b>	Sets the connection timeout period between 1 and 1000 seconds.
	<b>IP Filter (IPv4)</b>	To set the IP Filter settings, click <b>IP Filter (IPv4)</b> . The <b>IP Filter (IPv4)</b> page is displayed.
<b>IPP*<sup>1</sup></b>	<b>Printer URI</b>	Displays the printer URI.
	<b>Connection Time-Out</b>	Sets the connection timeout period from 1 to 1000 seconds.
	<b>Port Number</b>	Displays the port number for receiving requests from the client.
	<b>Maximum Sessions</b>	Displays the maximum number of connections received simultaneously by the client.
<b>WSD</b>	<b>Port Number</b>	Sets the port number from 8000 to 9999.
	<b>Receive Time-Out</b>	Sets the receive timeout period from 1 to 65535 seconds.
	<b>Notification Time-Out</b>	Sets the notification timeout period from 1 to 60 seconds.
	<b>Maximum Number of TTL</b>	Sets the maximum number of TTL from 1 to 10.
<b>HTTP</b>	<b>Maximum Number of Notification</b>	Sets the maximum number of notifications from 10 to 20.
	<b>Port Number</b>	Sets the port number to 80 or from 8000 to 9999.
	<b>Simultaneous Connections</b>	Displays the maximum number of connections received simultaneously by the client.
<b>IP Filter (IPv4)*<sup>2</sup></b>	<b>Connection Time-Out</b>	Sets the connection timeout period from 1 to 255 seconds.
	<b>Address</b>	Sets the address in the address field. Enter a numeric value between 0 and 255 in each field of "aaa.bbb.ccc.ddd." However, 127 and 224 to 254 cannot be used to "aaa."
	<b>Address Mask</b>	Sets the Subnet Mask in the Mask field. Enter a numeric value between 0 and 255 in each field.
	<b>Active Mode</b>	<b>Reject</b>
<b>Permit</b>		Permits printing from specified network address.
<b>Disabled</b>		Disables the IP Filter feature for the specified IP address.

\*<sup>1</sup> An optional network protocol adapter is required to display the item.

\*<sup>2</sup> This item is only available for LPD or Port9100.

To configure the IP Filter feature, enter an IP address to be filtered in the Address field and the Subnet Mask in the Address Mask field. Enter a numeric value between 0 and 255 in each field. "\*" is appended to the current value.

#### Setup Procedure

You can set up to a maximum of five items and the first item takes priority. Enter the shortest address first before proceeding to the next longer address when setting multiple filters.

The following section explains how the **IP Filter (IPv4)** operates.

1. IP Filter Procedure
  - a. Enabling Printing From a Specified User

The following describes the procedure to enable printing only from the "192.168.100.10" IP address.

#### Procedures:

- i. Click the first column of **Access List** row **1**.
- ii. Enter "192.168.100.10" in the **Address** field and "255.255.255.255" in the **Address Mask** field.
- iii. Select **Permit**.
- iv. Click **Apply New Settings**.
- b. Disabling Printing From a Specified User

The following describes the procedure to disable printing only from the "192.168.100.10" IP address.

**Procedures:**

- i. Click the first column of **Access List** row **1**.
  - ii. Enter "192.168.100.10" in the **Address** field and "255.255.255.255" in the **Address Mask** field.
  - iii. Select **Reject**.
  - iv. Click the first column of **Access List** row **2**.
  - v. Enter "0.0.0.0" in the **Address** field and "0.0.0.0" in the **Address Mask** field.
  - vi. Select **Permit**.
  - vii. Click **Apply New Settings**.
- c. Enabling and Disabling Printing from Network Addresses

You can enable printing from the "192.168" network address and disable printing from the "192.168.200" network address. However, the example below describes how to enable printing from the "192.168.200.10" IP address.

**Procedures:**

- i. Click the first column of the **Access List** row **1**.
- ii. Enter "192.168.200.10" in the **Address** field and "255.255.255.255" in the **Address Mask** field.
- iii. Select **Permit**.
- iv. Click the first column of the **Access List** row **2**.
- v. Enter "192.168.200.0" in the **Address** field and "255.255.255.0" in the **Address Mask** field.
- vi. Select **Reject**.
- vii. Click the first column of the **Access List** row **3**.
- viii. Enter "192.168.0.0" in the **Address** field and "255.255.0.0" in the **Address Mask** field.
- ix. Select **Permit**.
- x. Click **Apply New Settings**.

**NetWare**

**Purpose:**

To configure detailed settings for IPX/SPX and NetWare.

**Values:**

<b>IPX/SPX Settings</b>	<b>Frame Type</b>	<b>Auto</b>	Specifies the active frame type automatically.
		<b>Ethernet II</b>	Selects Ethernet II frame type.
		<b>Ethernet 802.3</b>	Selects IEEE802.3 frame type.
		<b>Ethernet 802.2</b>	Selects IEEE802.2 frame type.
		<b>Ethernet SNAP</b>	Selects SNAP frame type.
	<b>Current Frame Type</b>	Displays the current frame type.	
	<b>Network Address</b>	Displays the IPX network address.	
<b>NetWare</b>	<b>Device Name*1</b>	Specifies the printer name up to 47 alphanumeric characters. For PServer Mode, set the Print Server Name (Print Server Object Name). The original setting remains valid if no input is made.	
	<b>Active Mode</b>	<b>Directory: PServer Mode</b>	Selects this option when using in <b>Directory: PServer Mode</b> .
		<b>Bindery: PServer Mode</b>	Selects this option when using in <b>Bindery: PServer Mode</b> .
	<b>Tree Name*1</b>	Specifies the tree name up to 32 alphanumeric characters. Configure this item only when <b>Directory: PServer Mode</b> is selected.	
	<b>Context Name</b>	Specifies the context name of the Print Server Object up to 255 alphanumeric characters. Configure this item only when <b>Directory: PServer Mode</b> is selected.	
	<b>File Server Name*1</b>	Specifies the file server name up to 47 alphanumeric characters. Configure this item only when <b>Bindery: PServer Mode</b> is selected.	
	<b>Polling Interval</b>	Sets the time interval from when print data enters the print queue until printing starts. The setting range is from 1 to 1000 seconds. The original setting remains valid if no input is made. Configure this item only when <b>Bindery: PServer Mode</b> or <b>Directory: PServer Mode</b> is selected.	
<b>Password</b>	Sets the print server password up to 32 alphanumeric characters. Configure this item only when <b>Bindery: PServer Mode</b> or <b>Directory: PServer Mode</b> is selected.		

	<b>Re-enter Password</b>	Enter the password again.
	<b>Status Information</b>	Displays the status of NetWare.
<b>SLP</b>	<b>Active Discovery</b>	Select the check box to enable <b>Active Discovery</b> .
*1 The following are illegal characters: semicolon (;), colon (:), asterisk (*), question mark (?), period (.), comma (,), yen mark (¥), back slash (\), double quotation ("), comparison symbols (< >), brackets ([ ]), operation symbols (+, =, or -), pipe ( ), slash (/), and space ( ).		

 **NOTE:** The settings in the **NetWare** page will be valid only when NetWare or the printer is rebooted. Click the **Apply new settings** button to apply new settings.

 **NOTE:** An optional network protocol adapter is required to display the **NetWare** page.

## SMB

### Purpose:

To configure detailed settings for SMB.

### Values:

<b>Host Name</b>	Specifies the host name up to 15 alphanumeric characters. The original setting will remain valid if no input is made.	
<b>Workgroup</b>	Specifies the workgroup name up to 15 alphanumeric characters. The original setting will remain valid if no input is made.	
<b>Administrator Name</b>	Specifies the administrator name up to 20 alphanumeric characters. The original setting will remain valid if no input is made. The default name is <i>admin</i> .	
<b>Administrator Password</b>	Specifies the administrator password up to 14 alphanumeric characters. The original setting will remain valid if no input is made. The default password is <i>password</i> .	
<b>Re-enter Administrator Password</b>	Allows you to confirm the configured administrator password by re-entering the same password.	
<b>Maximum Sessions</b>	Displays the maximum sessions.	
<b>Unicode Support</b>	<b>On</b>	Notifies the host name and workgroup name in Unicode characters.
	<b>Off</b>	Does not notify the host name and workgroup name in Unicode characters.
<b>Auto Master Mode</b>	<b>On</b>	Enable the Auto Master Mode.
	<b>Off</b>	Disable the Auto Master Mode.
<b>Encrypt Password</b>	<b>On</b>	Encrypts the password.
	<b>Off</b>	Does not encrypt the password.
<b>Job Time-Out</b>	Sets the timeout period from 60 to 3600 seconds.	
<b>Connection Time-Out</b>	Sets the connection timeout period from 60 to 3600 seconds.	

 **NOTE:** The settings in the **SMB** page will be valid only when the printer is rebooted. Click the **Apply new settings** button and reboot the printer to apply new settings.

 **NOTE:** An optional network protocol adapter is required to display the **SMB** page.

## AppleTalk

### Purpose:

To configure the detailed settings for AppleTalk.

### Values:

<b>Printer</b>	Specifies the printer name in the AppleTalk network up to 32 alphanumeric characters and symbol sets.
<b>AppleTalk Zone</b>	Specifies the AppleTalk zone name up to 32 alphanumeric characters and symbol sets.
<b>AppleTalk Type</b>	Displays the AppleTalk type.
<b>Delay Start Time</b>	Specifies the delay start time between 1 and 255 seconds. A zero (0) value specifies no delay.

 **NOTE:** An optional network protocol adapter is required to display the **AppleTalk** page.

## E-Mail Alert

### Purpose:

To configure detailed settings for E-Mail Alert. This page can also be displayed by clicking **E-Mail Alert** in the Left Frame.

### Values:

<b>E-Mail Server Settings</b>	<b>Primary SMTP Gateway</b>	Sets the primary SMTP gateway.	
	<b>SMTP Port Number</b>	Specifies the SMTP port number. This must be 25, 587 or between 5000 and 65535.	
	<b>E-Mail Send Authentication</b>	Specifies the authentication method for outgoing e-mail.	
	<b>SMTP Login User</b>	Specifies the SMTP login user. Up to 63 alphanumeric characters, periods, hyphens, under bars, and at symbols (@) can be used. If specifying more than one address, separate them using commas.	
	<b>SMTP Login Password</b>	Specifies the SMTP account password using up to 31 alphanumeric characters.	
	<b>Re-enter SMTP Login Password</b>	Enter the SMTP account password again to confirm it.	
	<b>POP3 Server Address*1</b>	Specifies the POP3 server address in IP address format of "aaa.bbb.ccc.ddd" or as a DNS host name using up to 63 characters.	
	<b>POP3 Port Number*1</b>	Specifies the POP3 server port number. This must be 110 or between 5000 and 65535.	
	<b>POP User Name*1</b>	Specifies the POP3 account user name. Up to 63 alphanumeric characters, periods, hyphens, under bars, and at symbols (@) can be used. If specifying more than one address, separate them using commas.	
	<b>POP User Password*1</b>	Specifies the POP3 account password using up to 31 alphanumeric characters.	
	<b>Re-enter POP User Password*1</b>	Enter the POP3 account password again to confirm it.	
	<b>Reply Address</b>	Designates the reply e-mail address sent with each E-mail Alert.	
	<b>SMTP Server Connection</b>	Displays the status of the SMTP server connection.	
	<b>E-Mail Alert Settings</b>	<b>E-Mail List 1</b>	Sets acceptable e-mail addresses for the E-Mail Alert feature using up to 255 alphanumeric characters.
<b>Select Alerts for List 1</b>		<b>Supplies Alerts</b>	Select the check box to receive an E-Mail Alert for consumables.
		<b>Paper Handling Alerts</b>	Select the check box to receive an E-Mail Alert for paper handling.
		<b>Service Call</b>	Select the check box to receive an E-Mail Alert for Service Calls.
<b>E-Mail List 2</b>		Sets acceptable e-mail addresses for the E-Mail Alert feature using up to 255 alphanumeric characters.	
<b>Select Alerts for List 2</b>		<b>Supplies Alerts</b>	Select the check box to receive an E-Mail Alert for consumables.
		<b>Paper Handling Alerts</b>	Select the check box to receive an E-Mail Alert for paper handling.
	<b>Service Call</b>	Select the check box to receive an E-Mail Alert for Service Calls.	
*1 Available when <b>POP before SMTP for E-Mail Send Authentication</b> is selected.			

## Bonjour (mDNS)

### Purpose:

To configure the detailed settings for Bonjour.

### Values:

<b>Host Name</b>	Specifies the host name up to 63 alphanumeric characters and "-" (dash). The original setting will remain valid if no input is made.
<b>Printer Name</b>	Specifies the printer name up to 63 alphanumeric characters and symbol sets. The original setting will remain valid if no input is made.

 **NOTE:** An optional network protocol adapter is required to display the **Bonjour (mDNS)** page.

## SNMP

### Purpose:

To configure the detailed settings of SNMP.

### Values:

<b>Enable SNMP v1/v2c Protocol</b>	Select the check box to enable the SNMP v1/v2c protocol.
<b>Edit SNMP v1/v2c Properties</b>	Click to display <a href="#">SNMP v1/v2c</a> page and to edit the setting of SNMP v1/v2c protocol from the page.
<b>Enable SNMP v3 Protocol</b>	Select the check box to enable the SNMP v3 protocol.
<b>Edit SNMP v3 Properties</b>	Click to display <a href="#">SNMP v3</a> page and to edit the setting of SNMP v3 protocol from the page. Without SSL communication is enabled, you cannot click this item.

## SNMP v1/v2c

### Purpose:



To edit the detailed settings of SNMP v1/v2c protocol.

To enter this page, click **Edit SNMP v1/v2c Properties** in the [SNMP](#) page.

Values:

<b>Community Name (Read only)*<sup>1</sup></b>	Specifies the community name to access (read only) data using up to 31 alphanumeric characters. The original setting will remain valid if no input is made. Characters entered for community name in the previous settings will not be displayed on the screen. The default Read Community is public.
<b>Re-enter Community Name (Read only)*<sup>1</sup></b>	Enter the community name to access (read only) data again to confirm it.
<b>Community Name (Read/Write)*<sup>1</sup></b>	Specifies the community name to access (read and write) data using up to 31 alphanumeric characters. The original setting will remain valid if no input is made. Characters entered for community name in the previous settings will not be displayed on the screen. The default Read/Write Community is private.
<b>Re-enter Community Name (Read/Write)*<sup>1</sup></b>	Enter the community name to access (read and write) data again to confirm it.
<b>Community Name (Trap)*<sup>1</sup></b>	Specifies the community name used for trap up to 31 alphanumeric characters. The original settings will remain valid if no input is made. Characters entered for Community Name (Trap) in the previous settings will not be displayed on the screen. The default Trap Community is " " (NULL).
<b>Re-enter Community Name (Trap)*<sup>1</sup></b>	Enter the community name used for trap again to confirm it.
<b>Trap Notification 1-4</b>	<p>Select the check boxes to notify trap occurrence. In this case, specify the IP address and IP socket in the following format:</p> <ul style="list-style-type: none"> <li>IPv4</li> </ul> <p>Specify the IP address and IP socket in the nnn.nnn.nnn.nnn:mmmmm format. Each section of "nnn" is a variable value between 0 and 255. Note that values 127 and 224-254 are not valid for the first three-digits only. IP socket mmmm is a variable value between 0 and 65535.</p> <ul style="list-style-type: none"> <li>IPv6</li> </ul> <p>Specify the IP address and IP socket in the xxxx:xxxx:xxxx:xxxx:xxxx:xxxx:xxxx:mmmmm format. Each section of "xxxx" is a hexadecimal variable value between 0 and ffff. IP socket mmmm is a variable value between 0 and 65535.</p> <ul style="list-style-type: none"> <li>IPX*<sup>2</sup></li> </ul> <p>Specify the IPX address in the nnnnnnnn.mmmmmmmmmmm.Illl format. IP network nnnnnnnn is a hexadecimal variable value between 0 and fffffff, IPX node mmmmmmmmmmm is a hexadecimal value between 0 and fffffff and IPX socket Illl is a hexadecimal variable value between 0 and ffff.</p>
<b>Authenticate Error Trap</b>	Select the check box to notify Authenticate Error Trap.
* <sup>1</sup> The default value of each items can be changed by using Dell Printer Configuration Web Tool.	
* <sup>2</sup> An optional network protocol adapter is required to display the item.	

### SNMP v3

Purpose:

To edit the detailed settings of SNMP v3 protocol.

To enter this page, click **Enable SNMP v3 Protocol** in the [SNMP](#) page.

Values:

<b>Administrator Account</b>	<b>Account Enabled</b>	Select the check box to enable the administrator account.
	<b>User Name</b>	Enter the user name of the administrator account.
	<b>Authentication Password</b>	Specifies the authentication password of the administrator account using 8 to 32 alphanumeric characters.
	<b>Re-enter Authentication Password</b>	Enter the authentication password of the administrator account again to confirm it.
	<b>Privacy Password</b>	Specifies the privacy password of the administrator account using 8 to 32 alphanumeric characters.
	<b>Re-enter Privacy Password</b>	Enter the privacy password of the administrator account again to confirm it.
<b>Print Drivers / Remote Client Account</b>	<b>Account Enabled</b>	Select the check box to enable the print drivers and remote client account.
	<b>Reset to default Password</b>	Click to reset the password for the print drivers and remote client account to default.

### Other Features

The **Other Features** tab includes **Set Password**, **SSL/TLS**, **IPsec**, **802.1x**, and **Reset Print Server** pages.

#### Set Password

Purpose:

To set or change the password that is required to access the printer's setup parameters from the **Dell Printer Configuration Web Tool**.

Set the password of the operator panel from **Panel Lock** in the **Printer Settings**. This page can also be displayed by clicking **Set Password** in the Left Frame.

 **NOTE:** To restore the password to the default (NULL), initialize the non-volatile memory (NVM).

**Values:**

<b>Administrator Password</b>	Sets the password using up to 10 alphanumeric characters. The password will appear as asterisks (*) in the field when it is entered.
<b>Re-enter Administrator Password</b>	Enter the password again to confirm.

## SSL/TLS

**Purpose:**

To specify the settings for the SSL encryption communication to the printer.

**Values:**

<b>HTTPS</b>	Select the check box to enable the HTTPS, and access is established using SSL communication. Without setting <b>Generate Self-Signed Certificate</b> , you cannot select this check box.	
<b>Port Number</b>	Specifies the port number, which is not identical with that of HTTP for TCP/IP. This must be 443 or between 8000 and 9999.	
<b>Generate Self-Signed Certificate</b>	Click to display <b>Generate Self-Signed Certificate</b> page and to create a security certification from the page.	
	<b>Size of Public Key</b>	Select the size of public key.
	<b>Issuer</b>	Display the issuer of SSL self-signed certificate.
	<b>Generate Signed Certificate</b>	Click to generate the SSL self-signed certificate.
<b>Manage Certificate</b>	Click to display <b>Manage Certificate</b> page and to manage a security certification from the page.	
	<b>Manage Certificate</b>	Display the SSL certificate information.
	<b>Delete</b>	Delete the SSL certificate.
	<b>Delete Certificate and Restart Printer</b>	Delete the SSL certificate and restart the printer.

## IPsec

**Purpose:**

To specify the Security Architecture settings for Internet Protocol (IPsec) for encrypted communication to the printer.

**Values:**

<b>Protocol</b>	Select the check box to enable the protocol.
<b>IKE</b>	Use a preshared key for IKE authentication.
<b>Pre-Shared Key</b>	Specifies a shared key.
<b>Re-enter Pre-Shared Key</b>	Enter the shared key again to confirm it.
<b>IKE SA Lifetime</b>	Sets the lifetime for IKE SA from 5 to 28800 minutes.
<b>IPsec SA Lifetime</b>	Sets the lifetime for IPsec SA from 5 to 2880 minutes.
<b>DH Group</b>	Selects the DH group.
<b>PFS</b>	Selects the check box to enable the PFS setting.
<b>Remote peers IPv4 address</b>	Specifies the IP address to connect to.
<b>Remote peers IPv6 address</b>	Specifies the IP address to connect to.
<b>Non IPsec communication policy</b>	Selects whether or not to communicate with a device which does not support IPsec.

 **NOTE:** If IPsec is enabled with incorrect settings, you must disable it using the **Reset IPsec** menu on the operator panel.

## 802.1x

**Purpose:**

To specify the settings for IEEE 802.1x authentication for encrypted communication to the printer.

 **NOTE:** This item is only displayed when the optional network protocol adapter is installed, and also when the optional wireless printer adapter is not installed.

**Values:**

<b>Enable IEEE 802.1x</b>	Select the check box to enable IEEE 802.1x authentication.	
<b>Authentication Method</b>	<b>EAP-MD5</b>	Select the authentication method to use for IEEE 802.1x authentication.
	<b>EAP-MS-CHAPv2</b>	
	<b>PEAP/MS-CHAPv2</b>	
<b>Login Name: (Device Name)</b>	Specifies the login name (device name) for IEEE 802.1x authentication using up to 128 alphanumeric characters.	
<b>Password</b>	Specifies the login password for IEEE 802.1x authentication using up to 128 alphanumeric characters.	
<b>Re-enter Password</b>	Enter the login password again to confirm it.	

**Reset Print Server****Purpose:**

To initialize NVRAM (non-volatile RAM) for the network feature and reboot the printer. You can also initialize the printer's NVRAM from **Reset Defaults** in the **Printer Settings** menu.

**Values:**

<b>Initialize NIC NVRAM Memory and restart printer.</b>	Click the <b>Start</b> button to initialize NVRAM. Network settings will revert to the factory default settings and reboot the network capability.
<b>Restart Printer</b>	Click the <b>Start</b> button to reboot the printer.

**Copy Printer Settings**

The **Copy Printer Settings** menu includes the **Copy Printer Settings** and **Copy Printer Settings Report** pages.

**Copy Printer Settings****Purpose:**

To copy the printer settings to one or more of the same model of the printer.

To copy the settings to another printer, specify the IP address and password of the printer to which the settings are copied in the **IP Address** text box and **Password** text box. Then, click the **Copy the settings to the Host in the above list.** button. Copying the settings is complete. The connection time-out period is 60 seconds. After that, you can check whether the settings were copied to this page. And you need to click the **Copy the settings to the Host in the above list and reboot the machine** button of the **Dell Printer Configuration Web Tool** in the destination printer to verify if the settings were actually copied or not.

If the settings can be copied but printer configuration is different, the settings of only the same items are copied. Printer settings are simultaneously copied to printer of up to 10 IP addresses.

**Copy Printer Settings Report****Purpose:**

To verify the histories of copying.

 **NOTE:** The history is cleared by turning off the printer.

**Print Volume**

The **Print Volume** menu includes the **Print Volume** and **Dell ColorTrack** pages.

**Print Volume****Purpose:**

To verify the number of printed pages. This page can also be displayed by clicking **Print Volume** in the Left Frame.

**Values:**

<b>Printer Page Count</b>	Displays the total number of pages printed since the printer was shipped from the factory.
<b>Paper Used</b>	Displays the number of pages printed for each paper size.

**Dell ColorTrack**

**Purpose:**

To specify which users have access to color printing and to limit print volume per user.

**Values:**

<b>Print User Limitation</b>	Select the check box to restrict users from using the printer.
<b>Permit printing without specifying user</b>	Select the check box to use the printer without user limitations.
<b>User Registration</b>	Displayed when <b>Print User Limitation</b> is enabled. To register a user, click <b>Edit User Registration</b> to open the <b>Edit Print User Registration</b> page, and then specify <b>User Registration No.</b> and click <b>Create</b> to open the <b>Print User Settings</b> page.

## Tray Settings

Use the **Tray Settings** menu to set the paper size and type of paper loaded in the trays.

**Values:**

<b>Tray 1 Paper Type</b>	Sets the type of paper loaded in the tray 1.
<b>Tray 1 Paper Size</b>	Sets the size of paper loaded in the tray 1.
<b>Tray 1 Custom Size - Y</b>	Sets the length of custom size paper loaded in the tray 1.
<b>Tray 1 Custom Size - X</b>	Sets the width of custom size paper loaded in the tray 1.
<b>Tray 2 Paper Type</b>	Sets the type of paper loaded in the optional 550 sheet feeder.
<b>Tray 2 Paper Size</b>	Sets the size of paper loaded in the optional 550 sheet feeder.
<b>Tray 2 Custom Size - Y</b>	Sets the length of custom size paper loaded in the optional 550 sheet feeder.
<b>Tray 2 Custom Size - X</b>	Sets the width of custom size paper loaded in the optional 550 sheet feeder.
<b>MPF Mode</b>	Sets the paper size and type when paper is loaded in the MPF.
<b>Display Popup</b>	Sets whether to display a popup message that prompts to set the paper size and type when paper is loaded in the tray 1.
<b>MPF Paper Type</b>	Sets the type of paper loaded in the MPF.
<b>MPF Paper Size</b>	Sets the size of paper loaded in the MPF.
<b>MPF Custom Size - Y</b>	Sets the length of custom size paper loaded in the MPF.
<b>MPF Custom Size - X</b>	Sets the width of custom size paper loaded in the MPF.

---

[Back to Contents Page](#)

## Installing Optional Modules

- [Installing the 550 Sheet Feeder](#)
- [Installing a Duplexer](#)
- [Installing a Memory](#)
- [Installing a Hard Disk](#)
- [Installing the Network Protocol Adapter](#)
- [Installing and Configuring the Wireless Printer Adapter](#)

You can make the printer more functional by installing the options. This chapter describes how to install the printer's options such as the duplexer and 550 sheet feeder.

---

### Installing the 550 Sheet Feeder

**⚠ CAUTION:** If you are adding a 550 sheet feeder after setting up the printer, be sure to turn off the printer, unplug the power cable, and disconnect all cables from the back of the printer before completing these tasks.

1. Turn off the printer and unplug the power cable. Then, disconnect all cables from the back of the printer.
2. Remove all packaging from the 550 sheet feeder.
3. Place the 550 sheet feeder in the location that the printer is located.
4. Lift the printer and align the four guide pins of the 550 sheet feeder with the holes at the bottom of the printer. Gently lower the printer onto the 550 sheet feeder.

**⚠ CAUTION:** To lift the printer safely, lift it with two people facing the front and back. Never try to lift the printer while facing its right and left sides.

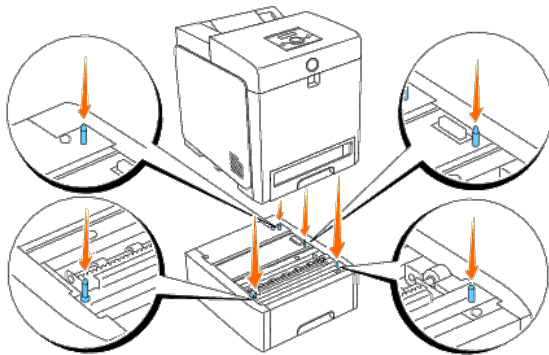

**⚠ CAUTION:** Be careful not to pinch your fingers when lowering the printer onto the 550 sheet feeder.

5. Pull the tray 1 out of the printer until it stops. Hold the tray with both hands, lift the front slightly, and remove it from the printer.

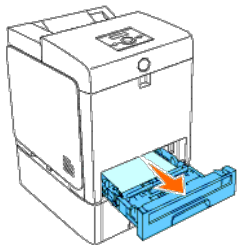

6. Join the 550 sheet feeder and the printer by tightening the two screws provided with the feeder with a coin or similar object.

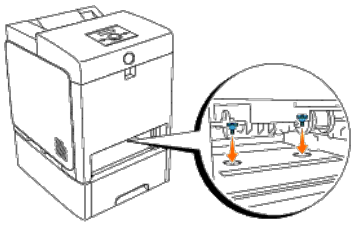

7. Insert the tray 1 into the printer, and push until it stops.

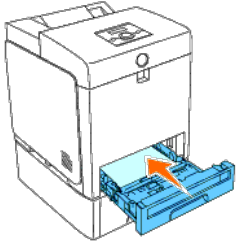

8. Reconnect all cables including the power cable into the back of the printer and turn on the printer.

 **NOTE:** The printer will automatically detect the attached tray but will not detect the paper type.

9. Print a printer settings page to verify the 550 sheet feeder is installed correctly.

## When Using the Operator Panel

- a. Press **Menu** button.
- b. Press **▼** button until **Report/List** appears, and then press **✓ (Set)** button.
- c. **Printer Setting** is displayed. Press **✓ (Set)** button.  
The printer settings page is printed.
- d. Verify **550 Sheet Feeder** is listed in the printer settings under **Printer Options**.

If the feeder is not listed, turn off the printer, unplug the power cable, and reinstall the 550 sheet feeder.

## When Using the Tool Box

- a. Click **start® All Programs® Dell Printers® Dell 3130cn Color Laser Printer® Tool Box**.

The **Select Printer** dialog box opens.

- b. Click **Dell 3130cn Color Laser PCL 6** listed in **Printer Name**, and then click **OK**.

The **Tool Box** opens.

- c. Click the **Printer Settings Report** tab.
- d. Select **Reports** from the list at the left side of the page.

The **Reports** page is displayed.

- e. Click the **Printer Settings** button.

The printer settings page is printed.

f. Verify **550 Sheet Feeder** is listed in the printer settings under **Printer Options**.

If the feeder is not listed, turn off the printer, unplug the power cable, and reinstall the 550 sheet feeder.

10. After loading paper in the installed tray, specify the paper type from the printer operator panel.

- a. Press **Menu** button.
- b. Press ▼ button until **Tray Settings** appears, and then press ✓ **(Set)** button.
- c. Press ▼ button until the installed tray appears, and then press ✓ **(Set)** button.
- d. Press ▼ button until **Paper Type** appears, and then press ✓ **(Set)** button.
- e. Press ▼ button until the paper type for the installed tray appears, and then press ✓ **(Set)** button.
- f. Confirm that the selected paper type is marked with an asterisk(\*), and then press **Menu** button.

11. If you installed the 550 sheet feeder after installing the printer driver, update your driver by following the instructions for each operating system. If the printer is on a network, update the driver for each client.

### When Using PCL Driver:

Windows® 7/7 x64/Windows Server® 2008 R2 x64	<ol style="list-style-type: none"> <li>1. Click <b>Start® Devices and Printers</b>.</li> <li>2. Right-click the printer icon and select <b>Printer properties</b>.</li> <li>3. Click the <b>Options</b> tab, and then select <b>Get Information from Printer</b>.</li> <li>4. Click <b>Apply</b>, and then click <b>OK</b>.</li> <li>5. Close the <b>Devices and Printers</b> dialog box.</li> </ol>
Windows Vista®/Vista x64	<ol style="list-style-type: none"> <li>1. Click <b>start® Control Panel® Hardware and Sound® Printers</b>.</li> <li>2. Right-click this printer icon and select <b>Properties</b>.</li> <li>3. Click the <b>Options</b> tab, and then select <b>Get Information from Printer</b>.</li> <li>4. Click <b>Apply</b>, and then click <b>OK</b>.</li> <li>5. Close the <b>Printers</b> dialog box.</li> </ol>
Windows Server 2008/Server 2008 x64	<ol style="list-style-type: none"> <li>1. Click <b>start® Control Panel® Printers</b>.</li> <li>2. Right-click this printer icon and select <b>Properties</b>.</li> <li>3. Click the <b>Options</b> tab, and then select <b>Get Information from Printer</b>.</li> <li>4. Click <b>Apply</b>, and then click <b>OK</b>.</li> <li>5. Close the <b>Printers</b> dialog box.</li> </ol>
Windows XP/XP x64/Server 2003/Server 2003 x64	<ol style="list-style-type: none"> <li>1. Click <b>start® Printers and Faxes</b>.</li> <li>2. Right-click the printer and select <b>Properties</b>.</li> <li>3. Click the <b>Options</b> tab, and then select <b>Get Information from Printer</b>.</li> <li>4. Click <b>Apply</b>, and then click <b>OK</b>.</li> <li>5. Close the <b>Printers and Faxes</b> dialog box.</li> </ol>
Windows 2000/NT® 4.0	<ol style="list-style-type: none"> <li>1. Click <b>start® Settings® Printers</b>.</li> <li>2. Right-click the printer and select <b>Properties</b>.</li> <li>3. Click the <b>Options</b> tab, and then select <b>Get Information from Printer</b>.</li> <li>4. Click <b>Apply</b>, and then click <b>OK</b>.</li> <li>5. Close the <b>Printers</b> dialog box.</li> </ol>

If the printer information is not updated automatically after clicking **Get Information from Printer**, follow these steps:

- 1. Click the **Options** tab, and then select **550 Sheet Feeder** on the **Items** list box.
- 2. Select **Available** for the 550 sheet feeder setting.
- 3. Click **Apply**, and then click **OK**.
- 4. Close the **Printers and Faxes**, **Printers**, or **Devices and Printers** dialog box.

### When Using PS Driver:

Windows 7/7 x64/Server 2008 R2 x64	<ol style="list-style-type: none"> <li>1. Click <b>Start® Devices and Printers</b>.</li> <li>2. Right-click the printer that is using the PS driver, and then select <b>Printer properties</b> from the displayed list.</li> <li>3. Click the <b>Device Settings</b> tab, and then select <b>2-Tray Module</b> for the <b>Paper Tray Configuration</b> item under <b>Installable Options</b>.</li> </ol>
------------------------------------	----------------------------------------------------------------------------------------------------------------------------------------------------------------------------------------------------------------------------------------------------------------------------------------------------------------------------------------------------------------------------------------------------------

	<ol style="list-style-type: none"> <li>Click <b>Apply</b>, and then click <b>OK</b>.</li> <li>Close the <b>Devices and Printers</b> dialog box.</li> </ol>
Windows Vista/Vista x64	<ol style="list-style-type: none"> <li>Click <b>start</b>® <b>Control Panel</b>® <b>Hardware and Sound</b>® <b>Printers</b>.</li> <li>Right-click the printer that is using the PS driver, and then select <b>Properties</b> from the displayed list.</li> <li>Click the <b>Device Settings</b> tab, and then select <b>2-Tray Module</b> for the <b>Paper Tray Configuration</b> item under <b>Installable Options</b>.</li> <li>Click <b>Apply</b>, and then click <b>OK</b>.</li> <li>Close the <b>Printers</b> dialog box.</li> </ol>
Windows Server 2008/Server 2008 x64	<ol style="list-style-type: none"> <li>Click <b>start</b>® <b>Control Panel</b>® <b>Printers</b>.</li> <li>Right-click the printer that is using the PS driver, and then select <b>Properties</b> from the displayed list.</li> <li>Click the <b>Device Settings</b> tab, and then select <b>2-Tray Module</b> for the <b>Paper Tray Configuration</b> item under <b>Installable Options</b>.</li> <li>Click <b>Apply</b>, and then click <b>OK</b>.</li> <li>Close the <b>Printers</b> dialog box.</li> </ol>
Windows XP/XP x64/Server 2003/Server 2003 x64	<ol style="list-style-type: none"> <li>Click <b>start</b>® <b>Printers and Faxes</b>.</li> <li>Right-click the printer that is using PS driver, and then select <b>Properties</b> from the displayed list.</li> <li>Click the <b>Device Settings</b> tab, and then select <b>2-Tray Module</b> for the <b>Paper Tray Configuration</b> item under <b>Installable Options</b>.</li> <li>Click <b>Apply</b>, and then click <b>OK</b>.</li> <li>Close the <b>Printers and Faxes</b> dialog box.</li> </ol>
Windows 2000/NT 4.0	<ol style="list-style-type: none"> <li>Click <b>start</b>® <b>Settings</b>® <b>Printers</b>.</li> <li>Right-click the printer that is using PS driver, and then select <b>Properties</b> from the displayed list.</li> <li>Click the <b>Device Settings</b> tab, and then select <b>2-Tray Module</b> for the <b>Paper Tray Configuration</b> item under <b>Installable Options</b>.</li> <li>Click <b>OK</b>.</li> <li>Close the <b>Printers</b> dialog box.</li> </ol>
Mac OS® X 10.5.x	<ol style="list-style-type: none"> <li>Select the <b>Print &amp; Fax</b> in <b>System Preferences</b>.</li> <li>Select the printer in <b>Printers</b> list, and click <b>Options &amp; Supplies</b>.</li> <li>Select <b>Driver</b>, and select the options that have been installed on the printers, and then click <b>OK</b>.</li> </ol>
Mac OS X 10.2.x/10.3.x/10.4.x	<ol style="list-style-type: none"> <li>Select the printer from the <b>Printer List</b> screen in <b>Print Center</b> (or <b>Printer Setup Utility</b>).</li> <li>Click <b>Printers</b> on the <b>Print Center</b> (or <b>Printer Setup Utility</b>) menu bar, and select <b>Show Info</b>.</li> <li>Select <b>Installable Options</b>, and select the options that have been installed on the printer, and then click <b>Apply Changes</b>.</li> </ol>

## Installing a Duplexer

**NOTICE:** To protect the drums of the print cartridges against bright light, close the front cover within five minutes. If the front cover remains open for more than five minutes, print quality may deteriorate.

- Ensure that the printer is turned off.
- Remove all packaging from duplexer.
- Push the side button and open the front cover.

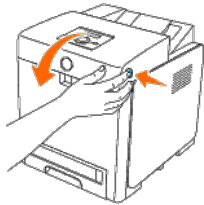

**NOTICE:** Ensure that nothing touches or scratches the surface (black-colored film) of the belt unit. Scratches, dirt, or oil from your hands on the film of the belt unit may reduce print quality.

- Pull up on the belt release levers and rotate the belt unit up as shown in the illustration.



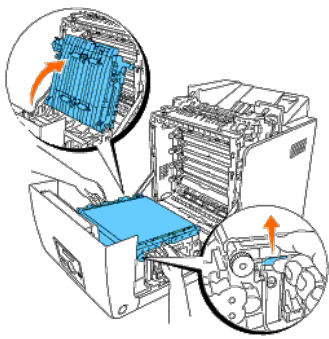

5. Remove the connector cap.

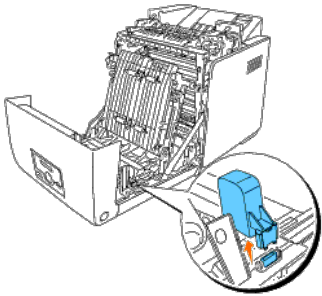

6. With the connector of the duplexer toward the slot, push the duplexer into the slot.

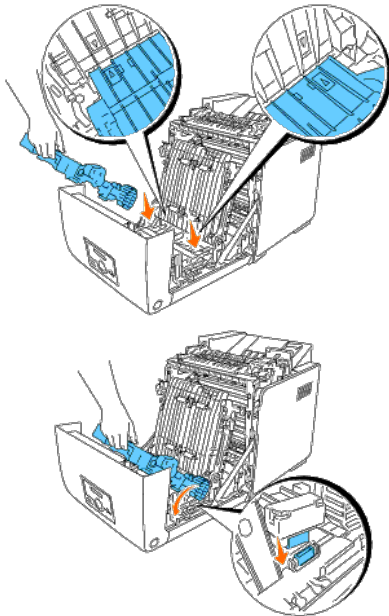

**NOTE:** Ensure that the duplexer is firmly fixed and cannot be moved easily.



7. Close the belt unit by pulling it down.

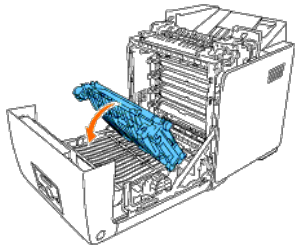

8. Close the front cover.

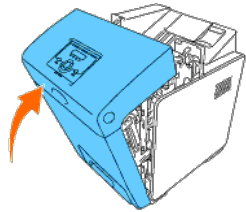

9. Turn on the printer.

10. Print a printer settings page to verify that the duplexer is installed correctly.

### When Using the Operator Panel

- a. Press **Menu** button.
- b. Press **▼** button until **Report/List** appears, and then press **✓ (Set)** button.
- c. **Printer Setting** is displayed. Press **✓ (Set)** button.

The printer settings page is printed.

- d. Verify **Duplexer** is listed in the printer settings under **Printer Options**.

If the duplexer is not listed, turn off the printer, unplug the power cable, and reinstall the duplexer.

### When Using the Tool Box

- a. Click **start**® **All Programs**® **Dell Printers**® **Dell 3130cn Color Laser Printer**® **Tool Box**.

The **Select Printer** dialog box opens.

- b. Click **Dell 3130cn Color Laser PCL 6** listed in **Printer Name**, and then click **OK**.

The **Tool Box** opens.

- c. Click the **Printer Settings Report** tab.
- d. Select **Reports** from the list at the left side of the page.

The **Reports** page is displayed.

- e. Click the **Printer Settings** button.

The printer settings page is printed.

f. Verify **Duplexer** is listed in the printer settings under **Printer Options**.

If the duplexer is not listed, turn off the printer, unplug the power cable, and reinstall the duplexer.

11. If you installed the duplexer after installing the printer driver, update your driver by following the instructions for each operating system. If the printer is on a network, update the driver for each client.

### When Using PCL Driver:

Windows 7/7 x64/Server 2008 R2 x64	<ol style="list-style-type: none"> <li>1. Click <b>Start</b>@ <b>Devices and Printers</b>.</li> <li>2. Right-click the printer icon and select <b>Printer properties</b>.</li> <li>3. Click the <b>Options</b> tab, and then select <b>Get Information from Printer</b>.</li> <li>4. Click <b>Apply</b>, and then click <b>OK</b>.</li> <li>5. Close the <b>Devices and Printers</b> dialog box.</li> </ol>
Windows Vista/Vista x64	<ol style="list-style-type: none"> <li>1. Click <b>start</b>@ <b>Control Panel</b>@ <b>Hardware and Sound</b>@ <b>Printers</b>.</li> <li>2. Right-click the printer and select <b>Properties</b>.</li> <li>3. Click the <b>Options</b> tab, and then select <b>Get Information from Printer</b>.</li> <li>4. Click <b>Apply</b>, and then click <b>OK</b>.</li> <li>5. Close the <b>Printers</b> dialog box.</li> </ol>
Windows Server 2008/Server 2008 x64	<ol style="list-style-type: none"> <li>1. Click <b>start</b>@ <b>Control Panel</b>@ <b>Printers</b>.</li> <li>2. Right-click the printer and select <b>Properties</b>.</li> <li>3. Click the <b>Options</b> tab, and then select <b>Get Information from Printer</b>.</li> <li>4. Click <b>Apply</b>, and then click <b>OK</b>.</li> <li>5. Close the <b>Printers</b> dialog box.</li> </ol>
Windows XP/XP x64/Windows Server 2003/Windows Server 2003 x64	<ol style="list-style-type: none"> <li>1. Click <b>start</b>@ <b>Printers and Faxes</b>.</li> <li>2. Right-click the printer and select <b>Properties</b>.</li> <li>3. Click the <b>Options</b> tab, and then select <b>Get Information from Printer</b>.</li> <li>4. Click <b>Apply</b>, and then click <b>OK</b>.</li> <li>5. Close the <b>Printers and Faxes</b> dialog box.</li> </ol>
Windows 2000/Windows NT 4.0	<ol style="list-style-type: none"> <li>1. Click <b>start</b>@ <b>Settings</b>@ <b>Printers</b>.</li> <li>2. Right-click the printer and select <b>Properties</b>.</li> <li>3. Click the <b>Options</b> tab, and then select <b>Get Information from Printer</b>.</li> <li>4. Click <b>Apply</b>, and then click <b>OK</b>.</li> <li>5. Close the <b>Printers</b> dialog box.</li> </ol>

If the printer information is not updated automatically after clicking **Get Information from Printer**, follow these steps:

1. Click the **Options** tab, and then select **Duplexer** in the **Items** list box.
2. Select **Available** for the duplexer setting.
3. Click **Apply**, and then click **OK**.
4. Close the **Printers and Faxes**, **Printers**, or **Devices and Printers** dialog box.

### When Using PS Driver:

Windows 7/7 x64/Server 2008 R2 x64	<ol style="list-style-type: none"> <li>1. Click <b>Start</b>@ <b>Devices and Printers</b>.</li> <li>2. Right-click the printer that is using the PS driver, and then select <b>Printer properties</b> from the displayed list.</li> <li>3. Click the <b>Device Settings</b> tab, and then select <b>Available</b> for the <b>Duplexer</b> item under <b>Installable Options</b>.</li> <li>4. Click <b>Apply</b>, and then click <b>OK</b>.</li> <li>5. Close the <b>Devices and Printers</b> dialog box.</li> </ol>
Windows Vista/Vista x64	<ol style="list-style-type: none"> <li>1. Click <b>start</b>@ <b>Control Panel</b>@ <b>Hardware and Sound</b>@ <b>Printers</b>.</li> <li>2. Right-click the printer that is using the PS driver, and then select <b>Properties</b> from the displayed list.</li> <li>3. Click the <b>Device Settings</b> tab, and then select <b>Available</b> for the <b>Duplexer</b> item under <b>Installable Options</b>.</li> <li>4. Click <b>Apply</b>, and then click <b>OK</b>.</li> <li>5. Close the <b>Printers</b> dialog box.</li> </ol>
Windows Server 2008/Server 2008 x64	<ol style="list-style-type: none"> <li>1. Click <b>start</b>@ <b>Control Panel</b>@ <b>Printers</b>.</li> <li>2. Right-click the printer that is using the PS driver, and then select <b>Properties</b> from the displayed list.</li> <li>3. Click the <b>Device Settings</b> tab, and then select <b>Available</b> for the <b>Duplexer</b> item under <b>Installable Options</b>.</li> <li>4. Click <b>Apply</b>, and then click <b>OK</b>.</li> <li>5. Close the <b>Printers</b> dialog box.</li> </ol>

Windows XP/XP x64/Server 2003/Server 2003 x64	<ol style="list-style-type: none"> <li>1. Click <b>start® Printers and Faxes</b>.</li> <li>2. Right-click the printer that is using the PS driver, and then select <b>Properties</b> from the displayed list.</li> <li>3. Click the <b>Device Settings</b> tab, and then select <b>Available</b> for the <b>Duplexex</b> item under <b>Installable Options</b>.</li> <li>4. Click <b>Apply</b>, and then click <b>OK</b>.</li> <li>5. Close the <b>Printers and Faxes</b> dialog box.</li> </ol>
Windows 2000/NT 4.0	<ol style="list-style-type: none"> <li>1. Click <b>start® Settings® Printers</b>.</li> <li>2. Right-click the printer that is using the PS driver, and then select <b>Properties</b> from the displayed list.</li> <li>3. Click the <b>Device Settings</b> tab, and then select <b>Available</b> for the <b>Duplexex</b> item under <b>Installable Options</b>.</li> <li>4. Click <b>OK</b>.</li> <li>5. Close the <b>Printers</b> dialog box.</li> </ol>
Mac OS X 10.5.x	<ol style="list-style-type: none"> <li>1. Select the <b>Print &amp; Fax</b> in <b>System Preferences</b>.</li> <li>2. Select the printer in <b>Printers</b> list, and click <b>Options &amp; Supplies</b>.</li> <li>3. Select <b>Driver</b>, and select the options that have been installed on the printers, and then click <b>OK</b>.</li> </ol>
Mac OS X 10.2.x/10.3.x/10.4.x	<ol style="list-style-type: none"> <li>1. Select the printer from the <b>Printer List</b> screen in <b>Print Center</b> (or <b>Printer Setup Utility</b>).</li> <li>2. Click <b>Printers</b> on the <b>Print Center</b> (or <b>Printer Setup Utility</b>) menu bar, and select <b>Show Info</b>.</li> <li>3. Select <b>Installable Options</b>, and select the options that have been installed on the printer, and then click <b>Apply Changes</b>.</li> <li>4. Click <b>Apply</b>, and then click <b>OK</b>.</li> </ol>

## Installing a Memory

Your printer supports 512 MB and 1024 MB additional memory.

1. Ensure that the printer is turned off.
2. Turn the screw on the control board cover in a counter-clockwise direction and open the cover.

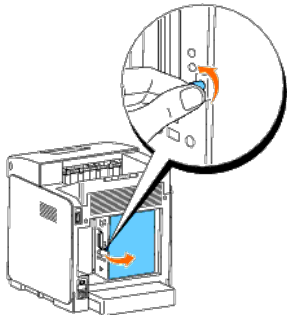

3. With the connector of the memory toward the slot, insert the memory at an angle into the slot.

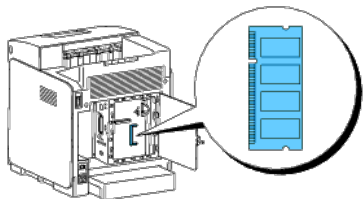

4. Push the memory into the slot firmly.

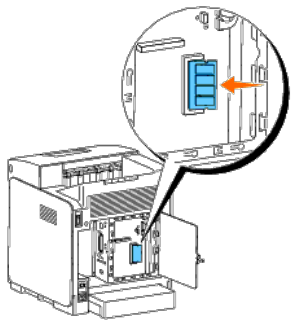

5. Pivot the memory downward until it clicks into place.

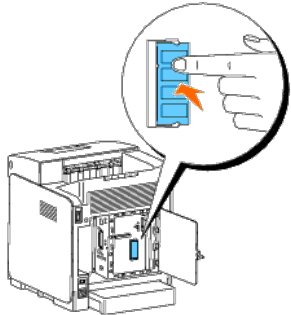

 **NOTE:** Ensure that the memory is firmly fixed in the slot and cannot be moved easily.

6. Close the control board cover and turn the screw clockwise.

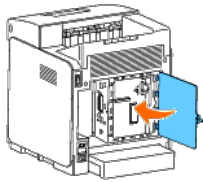

7. Turn on the printer.

8. Print a printer settings page to verify that the memory is installed correctly.

### When Using the Operator Panel

- a. Press **Menu** button.
- b. Press ▼ button until **Report/List** appears, and then press ✓ (**Set**) button.
- c. **Printer Setting** is displayed. Press ✓ (**Set**) button.

The printer settings page is printed.

- d. Verify **Memory Capacity** listed in the printer settings under **General**.

If the memory capacity has not increased, turn off the printer, unplug the power cable, and reinstall the memory.

### When Using the Tool Box

- a. Click **start**® **All Programs**® **Dell Printers**® **Dell 3130cn Color Laser Printer**® **Tool Box**.

The **Select Printer** dialog box opens.

- b. Click **Dell 3130cn Color Laser PCL 6** listed in **Printer Name**, and then click **OK**.

The **Tool Box** opens.

- c. Click the **Printer Settings Report** tab.
- d. Select **Reports** from the list at the left side of the page.

The **Reports** page is displayed.

- e. Click the **Printer Settings** button.

The printer settings page is printed.

- f. Verify **Memory Capacity** listed in the printer settings under **General**.

If the memory capacity has not increased, turn off the printer, unplug the power cable, and reinstall the memory.

9. If you installed the additional print memory after installing the printer driver, update your driver by following the instructions for the operating system you are using. If the printer is on a network, update the driver for each client.

### When Using PCL Driver:

Windows 7/7 x64/Server 2008 R2 x64	<ol style="list-style-type: none"> <li>1. Click <b>Start</b>® <b>Devices and Printers</b>.</li> <li>2. Right-click the printer and select <b>Printer properties</b>.</li> <li>3. Click the <b>Options</b> tab, and then select <b>Get Information from Printer</b>.</li> <li>4. Click <b>Apply</b>, and then click <b>OK</b>.</li> <li>5. Close the <b>Devices and Printers</b> dialog box.</li> </ol>
Windows Vista/Vista x64	<ol style="list-style-type: none"> <li>1. Click <b>start</b>® <b>Control Panel</b>® <b>Hardware and Sound</b>® <b>Printers</b>.</li> <li>2. Right-click the printer and select <b>Properties</b>.</li> <li>3. Click the <b>Options</b> tab, and then select <b>Get Information from Printer</b>.</li> <li>4. Click <b>Apply</b>, and then click <b>OK</b>.</li> <li>5. Close the <b>Printers</b> dialog box.</li> </ol>
Windows Server 2008/Server 2008 x64	<ol style="list-style-type: none"> <li>1. Click <b>start</b>® <b>Control Panel</b>® <b>Printers</b>.</li> <li>2. Right-click the printer and select <b>Properties</b>.</li> <li>3. Click the <b>Options</b> tab, and then select <b>Get Information from Printer</b>.</li> <li>4. Click <b>Apply</b>, and then click <b>OK</b>.</li> <li>5. Close the <b>Printers</b> dialog box.</li> </ol>
Windows XP/XP x64/Windows Server 2003/Windows Server 2003 x64	<ol style="list-style-type: none"> <li>1. Click <b>start</b>® <b>Printers and Faxes</b>.</li> <li>2. Right-click the printer and select <b>Properties</b>.</li> <li>3. Click the <b>Options</b> tab, and then select <b>Get Information from Printer</b>.</li> <li>4. Click <b>Apply</b>, and then click <b>OK</b>.</li> <li>5. Close the <b>Printers and Faxes</b> dialog box.</li> </ol>
Windows 2000/Windows NT 4.0	<ol style="list-style-type: none"> <li>1. Click <b>start</b>® <b>Settings</b>® <b>Printers</b>.</li> <li>2. Right-click the printer and select <b>Properties</b>.</li> <li>3. Click the <b>Options</b> tab, and then select <b>Get Information from Printer</b>.</li> <li>4. Click <b>Apply</b>, and then click <b>OK</b>.</li> <li>5. Close the <b>Printers</b> dialog box.</li> </ol>

If the printer information is not updated automatically after clicking **Get Information from Printer**, follow these steps:

1. Click the **Options** tab, and then select **Memory Capacity** in the **Items** list box.
2. Select the total amount of the installed print memory for the memory capacity setting.
3. Click **Apply**, and then click **OK**.
4. Close the **Printers and Faxes**, **Printers**, or **Devices and Printers** dialog box.

### When Using PS Driver:

Windows 7/7 x64/Server 2008 R2 x64	<ol style="list-style-type: none"> <li>1. Click <b>Start</b>® <b>Devices and Printers</b>.</li> </ol>
------------------------------------	-------------------------------------------------------------------------------------------------------

	<ol style="list-style-type: none"> <li>2. Right-click the printer that is using the PS driver, and then select <b>Printer properties</b> from the displayed list.</li> <li>3. Click the <b>Device Settings</b> tab, and then select memory size from <b>Memory Capacity</b> under <b>Installable Options</b>.</li> <li>4. Click <b>Apply</b>, and then click <b>OK</b>.</li> <li>5. Close the <b>Devices and Printers</b> dialog box.</li> </ol>
Windows Vista/Vista x64	<ol style="list-style-type: none"> <li>1. Click <b>start</b>® <b>Control Panel</b>® <b>Hardware and Sound</b>® <b>Printers</b>.</li> <li>2. Right-click the printer that is using the PS driver, and then select <b>Properties</b> from the displayed list.</li> <li>3. Click the <b>Device Settings</b> tab, and then select memory size from <b>Memory Capacity</b> under <b>Installable Options</b>.</li> <li>4. Click <b>Apply</b>, and then click <b>OK</b>.</li> <li>5. Close the <b>Printers</b> dialog box.</li> </ol>
Windows Server 2008/Server 2008 x64	<ol style="list-style-type: none"> <li>1. Click <b>start</b>® <b>Control Panel</b>® <b>Printers</b>.</li> <li>2. Right-click the printer that is using the PS driver, and then select <b>Properties</b> from the displayed list.</li> <li>3. Click the <b>Device Settings</b> tab, and then select memory size from <b>Memory Capacity</b> under <b>Installable Options</b>.</li> <li>4. Click <b>Apply</b>, and then click <b>OK</b>.</li> <li>5. Close the <b>Printers</b> dialog box.</li> </ol>
Windows XP/XP x64/Server 2003/Server 2003 x64	<ol style="list-style-type: none"> <li>1. Click <b>start</b>® <b>Printers and Faxes</b>.</li> <li>2. Right-click the printer that is using the PS driver, and then select <b>Properties</b> from the displayed list.</li> <li>3. Click the <b>Device Settings</b> tab, and then select memory size from <b>Memory Capacity</b> under <b>Installable Options</b>.</li> <li>4. Click <b>Apply</b>, and then click <b>OK</b>.</li> <li>5. Close the <b>Printers and Faxes</b> dialog box.</li> </ol>
Windows 2000/NT 4.0	<ol style="list-style-type: none"> <li>1. Click <b>start</b>® <b>Settings</b>® <b>Printers</b>.</li> <li>2. Right-click the printer that is using the PS driver, and then select <b>Properties</b> from the displayed list.</li> <li>3. Click the <b>Device Settings</b> tab, and then select memory size from <b>Memory Capacity</b> under <b>Installable Options</b>.</li> <li>4. Click <b>OK</b>.</li> <li>5. Close the <b>Printers</b> dialog box.</li> </ol>
Mac OS X 10.5.x	<ol style="list-style-type: none"> <li>1. Select the <b>Print &amp; Fax</b> in <b>System Preferences</b>.</li> <li>2. Select the printer in <b>Printers</b> list, and click <b>Options &amp; Supplies</b>.</li> <li>3. Select <b>Driver</b>, and select the options that have been installed on the printers, and then click <b>OK</b>.</li> </ol>
Mac OS X 10.2.x/10.3.x/10.4.x	<ol style="list-style-type: none"> <li>1. Select the printer from the <b>Printer List</b> screen in <b>Print Center</b> (or <b>Printer Setup Utility</b>).</li> <li>2. Click <b>Printers</b> on the <b>Print Center</b> (or <b>Printer Setup Utility</b>) menu bar, and select <b>Show Info</b>.</li> <li>3. Select <b>Installable Options</b>, and select the options that have been installed on the printer, and then click <b>Apply Changes</b>.</li> <li>4. Click <b>Apply</b>, and then click <b>OK</b>.</li> </ol>

## Installing a Hard Disk

1. Ensure that the printer is turned off.
2. Turn the screw on the control board cover in counterclockwise direction and open the cover.

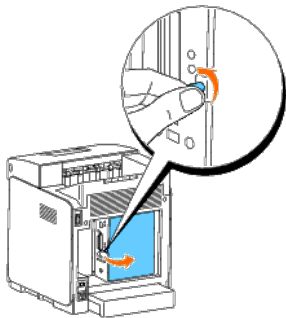

3. With the connector of the hard disk positioned over the connector on the control board, make connections together by pressing only on the lower edge of the hard disk.

 **NOTE:** When you connect the hard disk, make connections inside of the frame around the control board.

 **NOTE:** Avoid pressing down on the hard disk's connector.

 **NOTE:** Ensure that the hard disk is firmly fixed in the connector and cannot be moved easily.

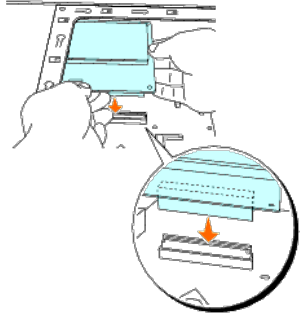
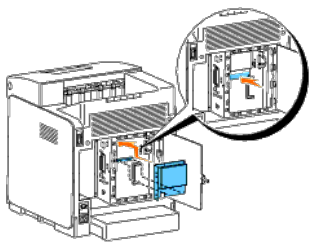

4. Press the two points on the hard disk as shown with your fingers to secure the hard disk to the connector.

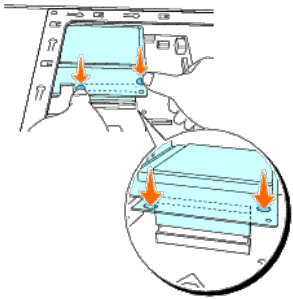

5. Insert the two screws through the control board case and into the hard disk as shown, and tighten the screws.

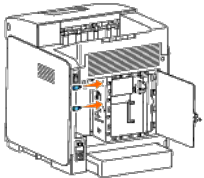

6. Close the control board cover and turn the screw clockwise.

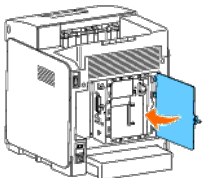



7. Reconnect power cable and turn on the printer.
8. Print a printer settings page to verify that the hard disk is installed correctly.

## When Using the Operator Panel

- a. Press **Menu** button.
- b. Press ▼ button until **Report/List** appears, and then press ✓ (**Set**) button.
- c. **Printer Setting** is displayed. Press ✓ (**Set**) button.  
The printer settings page is printed.
- d. Verify **Hard Disk** is listed in the printer settings under **Printer Options**.

If it is not listed, turn off the printer, unplug the power cable, and reinstall the hard disk.

## When Using the Tool Box

- a. Click **start® All Programs® Dell Printers® Dell 3130cn Color Laser Printer® Tool Box**.

The **Select Printer** dialog box opens.

- b. Click **Dell 3130cn Color Laser PCL 6** listed in **Printer Name**, and then click **OK**.

The **Tool Box** opens.

- c. Click the **Printer Settings Report** tab.
- d. Select **Reports** from the list at the left side of the page.

The **Reports** page is displayed.

- e. Click the **Printer Settings** button.

The printer settings page is printed.

- f. Verify **Hard Disk** is listed in the printer settings under **Printer Options**.

If it is not listed, turn off the printer, unplug the power cable, and reinstall the hard disk.

9. If you installed the hard disk after installing the printer driver, update your driver by following the instructions for each operating system. If the printer is on a network, update the driver for each client.

## When Using PCL Driver:

Windows 7/7 x64/Server 2008 R2 x64	<ol style="list-style-type: none"> <li>1. Click <b>Start® Devices and Printers</b>.</li> <li>2. Right-click the printer icon and select <b>Printer properties</b>.</li> <li>3. Click the <b>Options</b> tab, and then select <b>Get Information from Printer</b>.</li> <li>4. Click <b>Apply</b>, and then click <b>OK</b>.</li> <li>5. Close the <b>Devices and Printers</b> dialog box.</li> </ol>
Windows Vista/Vista x64	<ol style="list-style-type: none"> <li>1. Click <b>start® Control Panel® Hardware and Sound® Printers</b>.</li> <li>2. Right-click this printer icon and select <b>Properties</b>.</li> <li>3. Click the <b>Options</b> tab, and then select <b>Get Information from Printer</b>.</li> <li>4. Click <b>Apply</b>, and then click <b>OK</b>.</li> <li>5. Close the <b>Printers</b> dialog box.</li> </ol>
Windows Server 2008/Server 2008 x64	<ol style="list-style-type: none"> <li>1. Click <b>start® Control Panel® Printers</b>.</li> <li>2. Right-click this printer icon and select <b>Properties</b>.</li> <li>3. Click the <b>Options</b> tab, and then select <b>Get Information from Printer</b>.</li> <li>4. Click <b>Apply</b>, and then click <b>OK</b>.</li> <li>5. Close the <b>Printers</b> dialog box.</li> </ol>
Windows XP/XP x64/Server 2003/Server 2003 x64	<ol style="list-style-type: none"> <li>1. Click <b>start® Printers and Faxes</b>.</li> </ol>

	<ol style="list-style-type: none"> <li>2. Right-click the printer and select <b>Properties</b>.</li> <li>3. Click the <b>Options</b> tab, and then select <b>Get Information from Printer</b>.</li> <li>4. Click <b>Apply</b>, and then click <b>OK</b>.</li> <li>5. Close the <b>Printers and Faxes</b> dialog box.</li> </ol>
Windows 2000/NT 4.0	<ol style="list-style-type: none"> <li>1. Click <b>start</b>® <b>Settings</b>® <b>Printers</b>.</li> <li>2. Right-click the printer and select <b>Properties</b>.</li> <li>3. Click the <b>Options</b> tab, and then select <b>Get Information from Printer</b>.</li> <li>4. Click <b>Apply</b>, and then click <b>OK</b>.</li> <li>5. Close the <b>Printers</b> dialog box.</li> </ol>

If the printer information is not updated automatically after clicking **Get Information from Printer**, follow these steps:

1. Click the **Options** tab, and then select **Hard Disk** on the **Items** list box.
2. Select **Available** for the hard disk setting.
3. Click **Apply**, and then click **OK**.
4. Close the **Printers and Faxes**, **Printers**, or **Devices and Printers** dialog box.

### When Using PS Driver:

Windows 7/7 x64/Server 2008 R2 x64	<ol style="list-style-type: none"> <li>1. Click <b>Start</b>® <b>Devices and Printers</b>.</li> <li>2. Right-click the printer that is using the PS driver, and then select <b>Printer properties</b> from the displayed list.</li> <li>3. Click the <b>Device Settings</b> tab, and then select <b>Hard Disk</b> for the <b>Storage Device</b> item under <b>Installable Options</b>.</li> <li>4. Click <b>Apply</b>, and then click <b>OK</b>.</li> <li>5. Close the <b>Devices and Printers</b> dialog box.</li> </ol>
Windows Vista/Vista x64	<ol style="list-style-type: none"> <li>1. Click <b>start</b>® <b>Control Panel</b>® <b>Hardware and Sound</b>® <b>Printers</b>.</li> <li>2. Right-click the printer that is using the PS driver, and then select <b>Properties</b> from the displayed list.</li> <li>3. Click the <b>Device Settings</b> tab, and then select <b>Hard Disk</b> for the <b>Storage Device</b> item under <b>Installable Options</b>.</li> <li>4. Click <b>Apply</b>, and then click <b>OK</b>.</li> <li>5. Close the <b>Printers</b> dialog box.</li> </ol>
Windows Server 2008/Server 2008 x64	<ol style="list-style-type: none"> <li>1. Click <b>start</b>® <b>Control Panel</b>® <b>Printers</b>.</li> <li>2. Right-click the printer that is using the PS driver, and then select <b>Properties</b> from the displayed list.</li> <li>3. Click the <b>Device Settings</b> tab, and then select <b>Hard Disk</b> for the <b>Storage Device</b> item under <b>Installable Options</b>.</li> <li>4. Click <b>Apply</b>, and then click <b>OK</b>.</li> <li>5. Close the <b>Printers</b> dialog box.</li> </ol>
Windows XP/XP x64/Server 2003/Server 2003 x64	<ol style="list-style-type: none"> <li>1. Click <b>start</b>® <b>Printers and Faxes</b>.</li> <li>2. Right-click the printer that is using PS driver, and then select <b>Properties</b> from the displayed list.</li> <li>3. Click the <b>Device Settings</b> tab, and then select <b>Hard Disk</b> for the <b>Storage Device</b> item under <b>Installable Options</b>.</li> <li>4. Click <b>Apply</b>, and then click <b>OK</b>.</li> <li>5. Close the <b>Printers and Faxes</b> dialog box.</li> </ol>
Windows 2000/NT 4.0	<ol style="list-style-type: none"> <li>1. Click <b>start</b>® <b>Settings</b>® <b>Printers</b>.</li> <li>2. Right-click the printer that is using PS driver, and then select <b>Properties</b> from the displayed list.</li> <li>3. Click the <b>Device Settings</b> tab, and then select <b>Hard Disk</b> for the <b>Storage Device</b> item under <b>Installable Options</b>.</li> <li>4. Click <b>OK</b>.</li> <li>5. Close the <b>Printers</b> dialog box.</li> </ol>
Mac OS X 10.5.x	<ol style="list-style-type: none"> <li>1. Select the <b>Print &amp; Fax</b> in <b>System Preferences</b>.</li> <li>2. Select the printer in <b>Printers</b> list, and click <b>Options &amp; Supplies</b>.</li> <li>3. Select <b>Driver</b>, and select the options that have been installed on the printers, and then click <b>OK</b>.</li> </ol>
Mac OS X 10.2.x/10.3.x/10.4.x	<ol style="list-style-type: none"> <li>1. Select the printer from the <b>Printer List</b> screen in <b>Print Center</b> (or <b>Printer Setup Utility</b>).</li> <li>2. Click <b>Printers</b> on the <b>Print Center</b> (or <b>Printer Setup Utility</b>) menu bar, and select <b>Show Info</b>.</li> <li>3. Select <b>Installable Options</b>, and select the options that have been installed on the printer, and then click <b>Apply Changes</b>.</li> </ol>

## Installing the Network Protocol Adapter

The network protocol adapter allows you to use the following network protocols.

Network protocol	Supported OSes
802.1x(Wired)Except EAP-TLS/EAP-TTLS*1*3	Windows Server 2003/Windows Server 2003 x64
IPP(TCP/IP)	Windows 7/Windows 7 x64/Windows Vista/Windows Vista x64/Windows XP/XP x64/Windows Server 2003/Windows Server 2003 x64/Windows Server 2008/Windows Server 2008 x64/Windows Server 2008 R2

	x64/Windows 2000, Mac OS X 10.3.x/10.4.x/10.5.x
IPPS	Windows XP/Windows 2000, Mac OS X 10.4.x/10.5.x
SMB(TCP/IP)	Windows 7/Windows 7 x64/Windows Vista/Windows Vista x64/Windows XP/XP x64/Windows Server 2003/Windows Server 2003 x64/Windows Server 2008/Windows Server 2008 x64/Windows Server 2008 R2 x64/Windows 2000/Windows NT 4.0
SMB(NetBEUI)	Windows 2000/Windows NT 4.0
NetWare(P-Server) (NCP/IPX TCP/IP)	NetWare3.12/3.2(NDS unsupported)/4.1/4.11/4.2/5/6/6.5* <sup>2</sup>
AppleTalk	Mac OS X 10.2 or later
Bonjour(mDNS)	Mac OS X 10.2 or later
DDNS(TCP/IP)	Windows Server 2003/Windows Server 2003 x64/Windows Server 2008/Windows Server 2008 x64/Windows Server 2008 R2 x64/Windows 2000 Server/Unix(Solaris 9)

\*<sup>1</sup> This protocol is only available when the optional wireless printer adapter is not installed.

\*<sup>2</sup> Supports only Support Pack 1.1 or later.

\*<sup>3</sup> Supports EAP-MD5, EAP-MS-CHAPv2, and PEAP/MS-CHAPv2 for the authentication method.

1. Ensure that the printer is turned off and all the cables are unplugged from the printer.
2. Turn the screw on the control board cover in a counter-clockwise direction and open the cover.

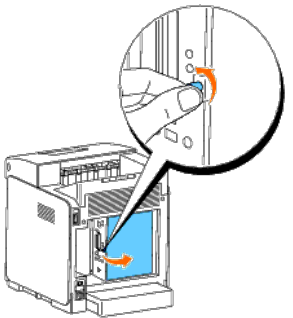

3. Insert the network protocol adapter by aligning the two rectangular slots and the circular hole and ensure that it snaps into place.

**NOTE:** Ensure that the network protocol adapter is firmly fixed in the connector.

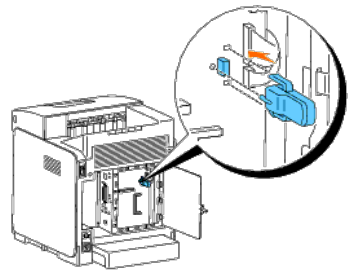

4. Close the control board cover and turn the screw clockwise.

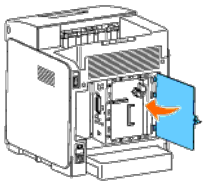

5. Reconnect all cables including the power cable into the back of the printer and turn on the printer.
6. Print a printer settings page to verify that the network protocol adapter is installed correctly.

## When Using the Operator Panel

- a. Press **Menu** button.
- b. Press ▼ button until **Report/List** appears, and then press ✓ (Set) button.
- c. **Printer Setting** is displayed. Press ✓ (Set) button.  
The printer settings page is printed.
- d. Verify **Network Protocol Adapter** is listed in the printer settings under **Printer Options**.

If it is not listed, turn off the printer, unplug the power cable, and reinstall the network protocol adapter.

## When Using the Tool Box

- a. Click **start**® **All Programs**® **Dell Printers**® **Dell 3130cn Color Laser Printer**® **Tool Box**.

The **Select Printer** dialog box opens.

- b. Click **Dell 3130cn Color Laser PCL 6** listed in **Printer Name**, and then click **OK**.

The **Tool Box** opens.

- c. Click the **Printer Settings Report** tab.
- d. Select **Reports** from the list at the left side of the page.

The **Reports** page is displayed.

- e. Click the **Printer Settings** button.

The printer settings page is printed.

- f. Verify **Network Protocol Adapter** is listed in the printer settings under **Printer Options**.

If it is not listed, turn off the printer, unplug the power cable, and reinstall the network protocol adapter.

## Installing and Configuring the Wireless Printer Adapter

The wireless printer adapter allows you to use the printer with wireless network connection.

The specifications of wireless printer adapter are described below.

Item	Specification
Connectivity Technology	Wireless
Compliant Standards	802.11b/ 802.11g
Bandwidth	2.4 GHz
Data Transfer Rate	802.11g: 54, 48, 36, 24, 18, 12, 9, 6 Mbps 802.11b: 11, 5.5, 2, 1 Mbps
Security	64 (40-bit key)/ 128 (104-bit key) WEP, WPA- PSK (TKIP, AES), WPA2- PSK (AES) (IEEE802.1x attestation function of WPA 1x non-corresponds)

 **NOTE:** When the Wireless Printer Adapter is installed, you cannot use IEEE 802.1x authentication and /or the Ethernet port for a wired connection.

## Contents of Box



1. Dell Wireless Network Adapter
2. Installing and Configuring the Wireless Printer Adapter Guide

 **NOTE:** To complete wireless installation you will require the corresponding *Drivers and Utilities* CD that comes with your printer which can also be downloaded from [support.dell.com](http://support.dell.com).

 **NOTE:** To complete wireless installation you will require a USB cable for temporary connection during configuration (sold separately).

## Before Installing the Wireless Printer Adapter

To install the Dell Wireless Printer Adapter, follow one of the methods:

Either

### Video instructions (Recommended)

1. Insert the *Drivers and Utilities* CD. The setup\_assist.exe file launches automatically.
2. Click the **How to Install Options** button on the **Easy Setup Navigator** window and follow on screen instructions.

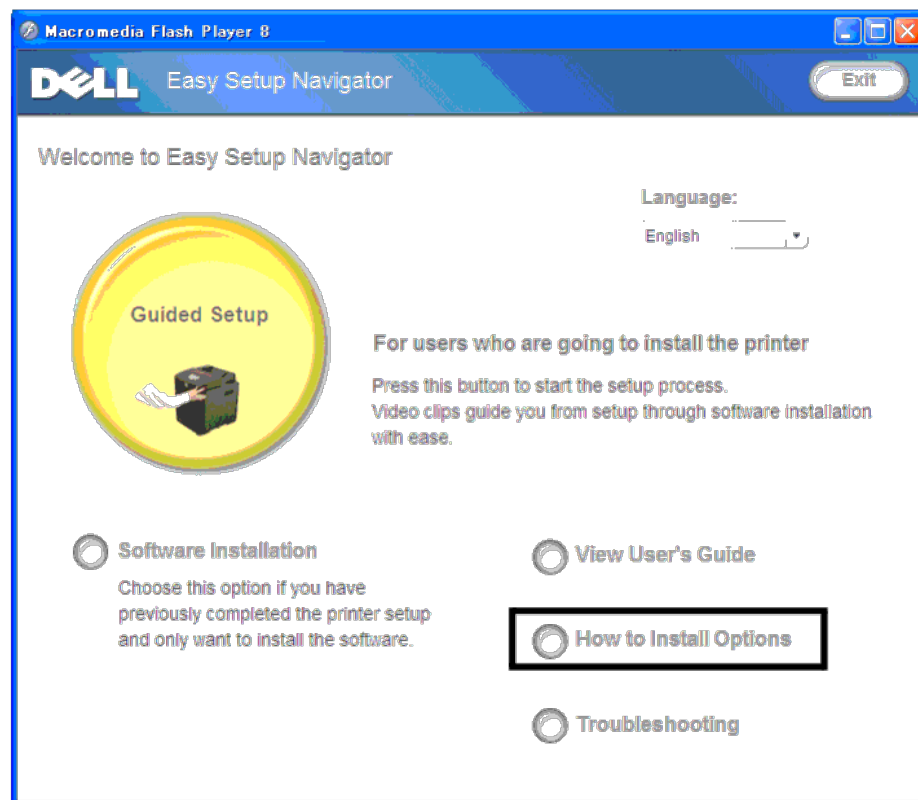

Or

### Paper instructions

## Installing the Wireless Printer Adapter

1. Ensure that the printer is turned off and unplug all cables including the power cable from the rear of the printer.

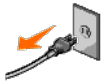

2. Remove the cap from the wireless printer adapter socket.

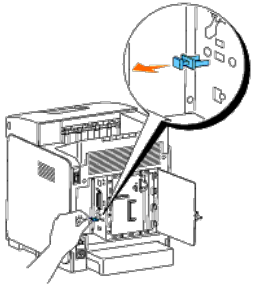

3. Insert the wireless printer adapter into the wireless printer adapter socket with adjusting two pins and a hook of the wireless printer adapter to the position of three holes around the wireless printer adapter socket.

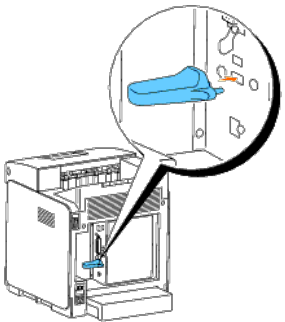

 **NOTE:** Ensure that the adapter is fully inserted and secured.

4. Reconnect the AC power cord and turn on the printer.
5. Print a Printer Settings page follow one of the two methods below.

### Method 1: Using the Printer's operator panel

- a. Press the **Menu** button
- b. Press the ▼ button until **Report/List** appears, and then press the ✓ (Set) button
- c. **Printer Settings** is displayed. Press the ✓ (Set) button

The **Printer Settings** page is printed.

### Method 2: Using the printer's Tool Box

- a. Click **start @ All Programs @ Dell Printers @ Dell 3130cn Color Laser Printer @ Tool Box**.

The **Select Printer** dialog box opens.

- b. Click **Dell 3130cn Color Laser PCL 6** listed in **Printer Name**, and then click **OK**.

The **Tool Box** opens.

- c. Click the **Printer Settings Report** tab.
- d. Select **Reports** from the list at the left side of the page.

The **Reports** page is displayed.

- e. Click the **Printer Settings** button.

The **Printer Settings** page is printed.

6. Verify that the **Network (Wireless)** section exists.

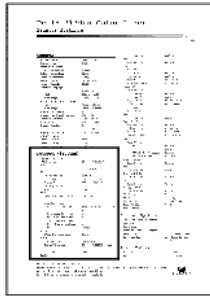

7. Insert the *Drivers and Utilities* CD provided with the printer. The **setup\_assist.exe** file launches automatically.

8. Click the **How to Install Options** button on the **Easy Setup Navigator** window.

The **How to Install Options** window opens.

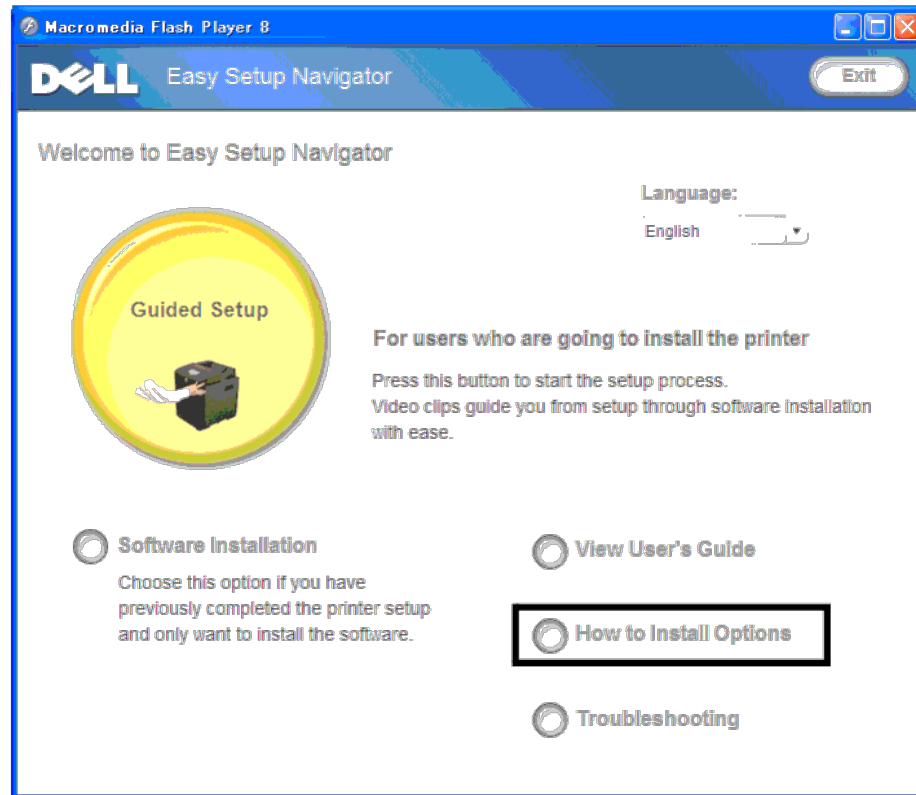

9. Click the **Wireless Printer Adapter** button and click **Skip Video**, to set printer's SSID.



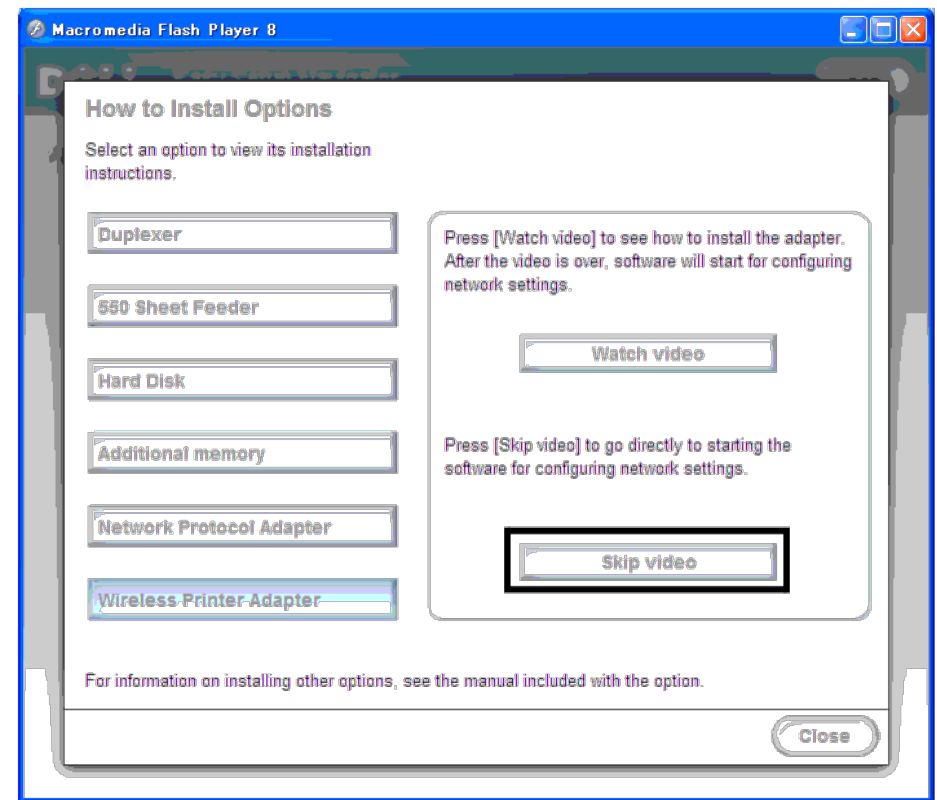
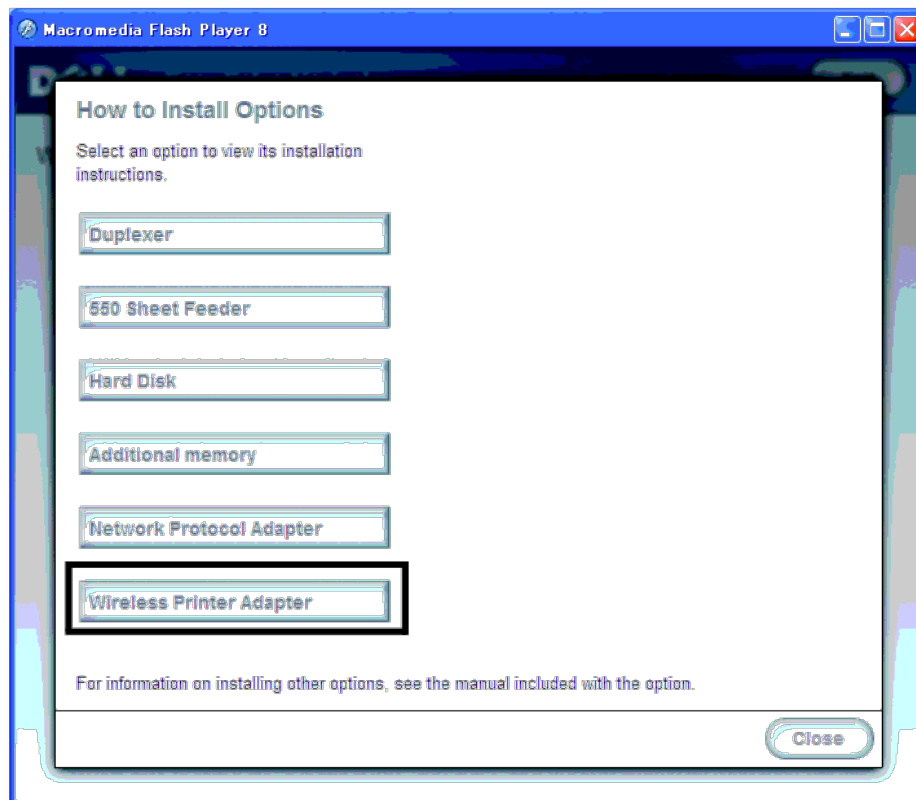

The **Wireless Settings Tool** window opens. Follow on screen instructions.

**NOTE:** For more information to configuring the Wireless Printer Adapter see ["Wireless Installation using Wireless Settings Tool"](#).

## Determining the Wireless Network Settings

You need to know the settings for the wireless network to set up the wireless printer. For details of the settings, contact your network administrator.

<b>Wireless Settings</b>	SSID	Specifies the name that identifies the wireless network. Up to 32 alphanumeric characters.
	Network Type	Specifies the network type from Ad-hoc or Infrastructure.
<b>Security Settings</b>	Security	Selects the security method from No security, WEP, WPA-PSK TKIP and WPA2-PSK-AES/WPA-PSK-AES.
	Transmit Key	Specifies the transmit key from the list.
	WEP Key	Specified the WEP key set used through the wireless network only when WEP is selected for Security.
	Pass Phrase	Specifies the pass phrase of alphanumeric characters from 8 to 63 bytes long only when WPA-PSK is selected for Encryption.

## Wireless Installation using Wireless Settings Tool

**NOTE:** The optional wireless printer adapter must be installed on the printer.

### Scene 1. Install a printer to the already-operating wireless network (When wireless setting is already set to your computer)

1. Insert the *Drivers and Utilities* CD into your computer to start **Easy Setup Navigator**.

 **NOTE:** If the CD does not automatically launch, click **start**® **All Programs** (for Windows Vista and Windows 7)® **Accessories** (for Windows Vista and Windows 7)® **Run**, and then type `D:\setup_assist.exe` (where D is the drive letter of your CD), and then click **OK**.

2. Press **How to Install Options** button.
3. Press **Wireless Printer Adapter**.
4. Press **Skip video** to launch the wireless settings tool.
5. In the list on the **Select Printer** screen, select the target printer that you are making wireless setting for, and then click **Next**.
6. On the **Enter Wireless Network Settings** screen, set each wireless setting item, and then click **Next**.
7. On the **Select IP Mode** screen, select the IP mode you want to setup, and then click **Next**.

**When IPv4 Only is selected:**

On the **Enter IPv4 Address Settings** screen, set each setting item, and then click **Send** to send the wireless settings to the printer.

**When IPv6 Only is selected:**

On the **Enter IPv6 Address Settings** screen, set each setting item, and then click **Send** to send the wireless settings to the printer.

**When Dual Stack (both IPv4 and IPv6) is selected:**

- a. On the **Enter IPv4 Address Settings** screen, set each setting item, and then click **Next**.
- b. On the **Enter IPv6 Address Settings** screen, set each setting item, and then click **Send** to send the wireless settings to the printer.

8. On the **Complete Wireless Settings** screen, click **Finish** to complete the wireless setting and close the wireless settings tool.

## Scene 2. Construct new wireless network environment for both computer and printer (When wireless setting needs to be set to your computer)

1. Insert the *Drivers and Utilities* CD into your computer to start **Easy Setup Navigator**.

 **NOTE:** If the CD does not automatically launch, click **start**® **All Programs** (for Windows Vista and Windows 7)® **Accessories** (for Windows Vista and Windows 7)® **Run**, and then type `D:\setup_assist.exe` (where D is the drive letter of your CD), and then click **OK**.

2. Press **How to Install Options** button.
3. Press **Wireless Printer Adapter**.
4. Press **Skip video** to launch the wireless settings tool.
5. In the list on the **Select Printer** screen, select the target printer that you are making wireless setting for, and then click **Next**.
6. On the **Enter Wireless Network Settings** screen, set each wireless setting item, and then click **Next**.
7. On the **Select IP Mode** screen, select the IP mode you want to setup, and then click **Next**.

**When IPv4 Only is selected:**

On the **Enter IPv4 Address Settings** screen, set each setting item, and then click **Send** to send the wireless settings to the printer.

**When IPv6 Only is selected:**

On the **Enter IPv6 Address Settings** screen, set each setting item, and then click **Send** to send the wireless settings to the printer.

**When Dual Stack (both IPv4 and IPv6) is selected:**

- a. On the **Enter IPv4 Address Settings** screen, set each setting item, and then click **Next**.
- b. On the **Enter IPv6 Address Settings** screen, set each setting item, and then click **Send** to send the wireless settings to the printer.

8. On the **Complete Wireless Settings** screen, click **Finish** to complete the wireless setting and close the wireless settings tool.
9. Create the wireless setting sent to the printer on your computer following the steps below.

 **NOTE:** If your computer provides a wireless printer adapter tool, change the wireless settings using this tool. Or you can change the wireless settings using the tool provided by the operating system. See the instructions below.

**For Windows XP and Windows Server 2003:**

- a. Select **Network Connections** from Control Panel.
- b. Right-click **Wireless Network Connection** and select **Properties**.
- c. Select the **Wireless Networks** tab.
- d. Ensure the check box for **Use Windows to configure my wireless network settings** is checked.
- e. Click **Advanced**.
- f. Do either of the following:

*When wireless ad-hoc mode is set to the printer:*

Select **Computer to Computer (ad hoc) networks only** and close the **Advanced** dialog box.

*When wireless infrastructure mode is set to the printer:*

Select **Access point (Infrastructure) networks only** and close the **Advanced** dialog box.

- g. Click **Add** to display **Wireless network properties**.
- h. Enter the setting that you send to the printer and click **OK**.
- i. Click **Move up** to move the setting to the top of the list.
- j. Click **OK** to close the **Property** dialog box.

#### **For Windows Vista:**

- a. Open **Control Panel**.
- b. Select **Network and Internet**.
- c. Select **Network and Sharing Center**.
- d. Select **Connect to a network**.
- e. Select the setting you send to the printer from the network items listed in **Connect to a network**.
- f. Select **Connect Anyway** in the warning dialog box indication indicating you are entering an unsecured area.
- g. Click **Close** in the dialog box after confirming the connection is a success.

#### **For Windows Server 2008:**

- a. Open **Control Panel**.
- b. Select **Network and Sharing Center**.
- c. Select **Connect to a network**.
- d. Select the setting you send to the printer from the network items listed in **Connect to a network**.
- e. Select **Connect Anyway** in the warning dialog box indication indicating you are entering an unsecured area.
- f. Click **Close** in the dialog box after confirming the connection is a success.

#### **For Windows Server 2008 R2 and Windows 7:**

- a. Open **Control Panel**.
- b. Select **Network and Internet**.
- c. Select **Network and Sharing Center**.
- d. Select **Connect to a network**.
- e. Select the setting you send to the printer from the network items listed in the available network list, and click **Connect**.
- f. Enter the **Security key** and click **OK**, if necessary.

## **Wireless Installation using Dell Printer Configuration Web Tool**

### **Scene 1. Install a printer to the already-operating wireless network (When wireless setting is already set to your computer)**

## For DHCP network:

1. Create wireless setting of your computer following the steps below.

 **NOTE:** If your computer provides a wireless printer adapter tool, change the wireless settings using this tool. Or you can change the wireless settings using the tool provided by the operating system. See the instructions below.

### For Windows XP and Windows Server 2003:

- a. Select **Network Connections** from Control Panel.
- b. Right-click **Wireless Network Connection** and select **Properties**.
- c. Select the **Wireless Networks** tab.
- d. Ensure the check box for **Use Windows to configure my wireless network settings** is checked.

 **NOTE:** Be sure to write down the current wireless computer settings in steps d and f so that you can restore them later.

- e. Click the **Advanced** button.
- f. Select **Computer to Computer (ad hoc) networks only** and close the **Advanced** dialog box.
- g. Click the **Add** button to display **Wireless network properties**.
- h. Under the **Association** tab, enter the following information and click **OK**.

Network name (SSID): dell\_device

Network Authentication: Open

Data encryption: Disabled

Ad hoc network: checked

- i. Click the **Move up** button to move the newly added SSID to the top of the list.
- j. Click **OK** to close the **Property** dialog box.

 **NOTE:** When your operating system is earlier than Windows 2000, create settings according to the manual of the wireless settings tool provided by your wireless device manufacturer.

### For Windows Vista:

- a. Open **Control Panel**.
- b. Select **Network and Internet**.
- c. Select **Network and Sharing Center**.
- d. Select **Connect to a network**.
- e. Select **dell\_device** from the network items listed in **Connect to a network**.
- f. Select **Connect Anyway** in the warning dialog box indicating you are entering an unsecured area.
- g. Click **Close** in the dialog box after confirming the connection is a success.

### For Windows Server 2008:

- a. Open **Control Panel**.
- b. Select **Network and Sharing Center**.
- c. Select **Connect to a network**.
- d. Select **dell\_device** from the network items listed in **Connect to a network**.
- e. Select **Connect Anyway** in the warning dialog box indicating you are entering an unsecured area.
- f. Click **Close** in the dialog box after confirming the connection is a success.

### For Windows Server 2008 R2 and Windows 7:

- a. Open **Control Panel**.
- b. Select **Network and Internet**.

- c. Select **Network and Sharing Center**.
  - d. Select **Connect to a network**.
  - e. Select **dell\_device** from the network items listed in the available network list, and click **Connect**.
2. Check the IP address assigned by AutoIP on the printer.

e.g.: 168.254.1.1

3. Check that the IP address on your computer is assigned by DHCP.
4. Open Dell Printer Configuration Web Tool using WEB browser.

e.g.: <http://168.254.1.1/>

5. Change the wireless setting of the printer on Dell Printer Configuration Web Tool.
6. Reboot the printer.
7. Restore the wireless setting on your computer.

 **NOTE:** If your computer provides a wireless printer adapter tool, change the wireless settings using this tool. Or you can change the wireless settings using the tool provided by the operating system. See the instructions below.

**For Windows XP and Windows Server 2003:**

- a. Select **Network Connections** from Control Panel.
- b. Right-click **Wireless Network Connection** and select **Properties**.
- c. Select **Wireless Network** tab.
- d. Click **Advanced**.
- e. Do either of the following:

*When wireless ad-hoc mode is set to the printer:*

Select **Computer to Computer (ad hoc) networks only** and close the **Advanced** dialog box.

*When wireless infrastructure mode is set to the printer:*

Select **Access point (Infrastructure) networks only** and close the **Advanced** dialog box.

- f. Select the setting that you send to the printer in the list in **Preferred Network** group.
- g. Click **Move up** to move the setting to the top of the list.
- h. Click **OK** to close the **Property** dialog box.

 **NOTE:** When your operating system is earlier than Windows 2000, create settings according to the manual of the wireless settings tool provided by your wireless device manufacturer.

**For Windows Vista:**

- a. Open **Control Panel**.
- b. Select **Network and Internet**.
- c. Select **Network and Sharing Center**.
- d. Select **Connect to a network**.
- e. Select the original setting from the network items listed in **Connect to a network**, and then click **Connect**.

**For Windows Server 2008:**

- a. Open **Control Panel**.
- b. Select **Network and Sharing Center**.
- c. Select **Connect to a network**.
- d. Select the original setting from the network items listed in **Connect to a network**, and then click **Connect**.

**For Windows Server 2008 R2 and Windows 7:**

- a. Open **Control Panel**.

- b. Select **Network and Internet**.
- c. Select **Network and Sharing Center**.
- d. Select **Connect to a network**.
- e. Select the original setting from the network items listed in the available network list, and then click **Connect**.

**For Fixed IP network:**

1. Create wireless setting of your computer following the steps below.

 **NOTE:** If your computer provides a wireless printer adapter tool, change the wireless settings using this tool. Or you can change the wireless settings using the tool provided by the operating system. See the instructions below.

**For Windows XP and Windows Server 2003:**

- a. Select **Network Connections** from Control Panel.
- b. Right-click **Wireless Network Connection** and select **Properties**.
- c. Select the **Wireless Networks** tab.
- d. Ensure the check box for **Use Windows to configure my wireless network settings** is checked.

 **NOTE:** Be sure to write down the current wireless computer settings in steps d and f so that you can restore them later.

- e. Click the **Advanced** button.
- f. Select **Computer to Computer (ad hoc) networks only** and close the **Advanced** dialog box.
- g. Click the **Add** button to display **Wireless network properties**.
- h. Under the **Association** tab, enter the following information and click **OK**.

Network name (SSID): dell\_device

Network Authentication: Open

Data encryption: Disabled

Ad hoc network: checked

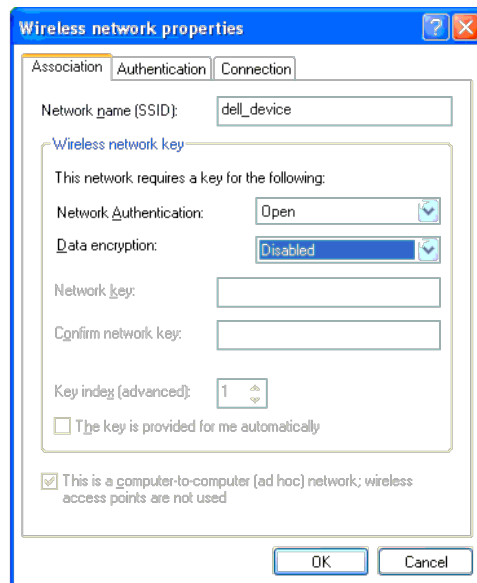

- i. Click the **Move up** button to move the newly added SSID to the top of the list.

j. Click **OK** to close the **Property** dialog box.

 **NOTE:** When your operating system is earlier than Windows 2000, create settings according to the manual of the wireless settings tool provided by your wireless device manufacturer.

**For Windows Vista:**

- a. Open **Control Panel**.
- b. Select **Network and Internet**.
- c. Select **Network and Sharing Center**.
- d. Select **Connect to a network**.
- e. Select **dell\_device** from the network items listed in **Connect to a network**.
- f. Select **Connect Anyway** in the warning dialog box indicating you are entering an unsecured area.
- g. Click **Close** in the dialog box after confirming the connection is a success.

**For Windows Server 2008:**

- a. Open **Control Panel**.
- b. Select **Network and Sharing Center**.
- c. Select **Connect to a network**.
- d. Select **dell\_device** from the network items listed in **Connect to a network**.
- e. Select **Connect Anyway** in the warning dialog box indicating you are entering an unsecured area.
- f. Click **Close** in the dialog box after confirming the connection is a success.

**For Windows Server 2008 R2 and Windows 7:**

- a. Open **Control Panel**.
- b. Select **Network and Internet**.
- c. Select **Network and Sharing Center**.
- d. Select **Connect to a network**.
- e. Select **dell\_device** from the network items listed in the available network list, and click **Connect**.

2. Check the IP address on your computer.

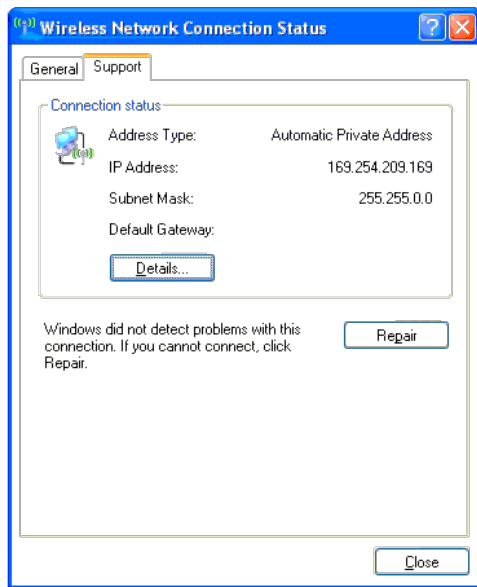

3. Set the IP address on the printer.

- a. Press **Menu** button.
- b. Scroll to **Admin** menu.
- c. Select **Network**.
- d. Select **TCP/IP**.
- e. Select **Get IP Address**.
- f. Select **Panel**.
- g. Scroll back to **IP Address**.
- h. Manually enter the IP address using the directional buttons on the control panel and press enter button.

IP Address 172.031.000.041*
--------------------------------

4. Open Dell Printer Configuration Web Tool using WEB browser.



**Dell 3130cn Color Laser**  
 IPv4: 172.31.0.41  
 IPv6(Link Local): fe80::260:b3ff:fe3f:ff1f  
 Location:  
 Contact Person:

**Printer Status** - Refresh

Cyan Cartridge Level ~ 100 %  
 Magenta Cartridge Level ~ 100 %  
 Yellow Cartridge Level ~ 100 %  
 Black Cartridge Level ~ 100 %

Paper Trays:	Status:	Capacity:	Size:

5. Change the wireless setting of the printer on Dell Printer Configuration Web Tool.
6. Reboot the printer.
7. Restore the wireless setting on your computer.

**NOTE:** If your computer provides a wireless printer adapter tool, change the wireless settings using this tool. Or you can change the wireless settings using the tool provided by the operating system. See the instructions below.

**For Windows XP and Windows Server 2003:**

- a. Select **Network Connections** from Control Panel.
- b. Right-click **Wireless Network Connection** and select **Properties**.
- c. Select **Wireless Network** tab.
- d. Click **Advanced**.
- e. Do either of the following:

*When wireless ad-hoc mode is set to the printer:*

Select **Computer to Computer (ad hoc) networks only** and close the **Advanced** dialog box.

*When wireless infrastructure mode is set to the printer:*

Select **Access point (Infrastructure) networks only** and close the **Advanced** dialog box.

- f. Select the setting that you send to the printer in the list in **Preferred Network** group.
- g. Click **Move up** to move the setting to the top of the list.
- h. Click **OK** to close the **Property** dialog box.

 **NOTE:** When your operating system is earlier than Windows 2000, create settings according to the manual of the wireless settings tool provided by your wireless device manufacturer.

**For Windows Vista:**

- a. Open **Control Panel**.
- b. Select **Network and Internet**.
- c. Select **Network and Sharing Center**.
- d. Select **Connect to a network**.
- e. Select the original setting from the network items listed in **Connect to a network**, and then click **Connect**.

**For Windows Server 2008:**

- a. Open **Control Panel**.
- b. Select **Network and Sharing Center**.
- c. Select **Connect to a network**.
- d. Select the original setting from the network items listed in **Connect to a network**, and then click **Connect**.

**For Windows Server 2008 R2 and Windows 7:**

- a. Open **Control Panel**.
- b. Select **Network and Internet**.
- c. Select **Network and Sharing Center**.
- d. Select **Connect to a network**.
- e. Select the original setting from the network items listed in the available network list, and then click **Connect**.

## Scene 2. Construct new wireless network environment for both computer and printer (When wireless setting needs to be set to your computer)

### For DHCP network:

1. Create wireless setting of your computer following the steps below.

 **NOTE:** If your computer provides a wireless printer adapter tool, change the wireless settings using this tool. Or you can change the wireless settings using the tool provided by the operating system. See the instructions below.

**For Windows XP and Windows Server 2003:**

- a. Select **Network Connections** from Control Panel.
- b. Right-click **Wireless Network Connection** and select **Properties**.
- c. Select the **Wireless Networks** tab.
- d. Ensure the check box for **Use Windows to configure my wireless network settings** is checked.

 **NOTE:** Be sure to write down the current wireless computer settings in steps e and g so that you can restore them later.

- e. Click the **Advanced** button.
- f. Select **Computer to Computer (ad hoc) networks only** and close the **Advanced** dialog box.
- g. Click the **Add** button to display **Wireless network properties**.
- h. Under the **Association** tab, enter the following information and click **OK**.

Network name (SSID): dell\_device

Network Authentication: Open

Data encryption: Disabled

Ad hoc network: checked

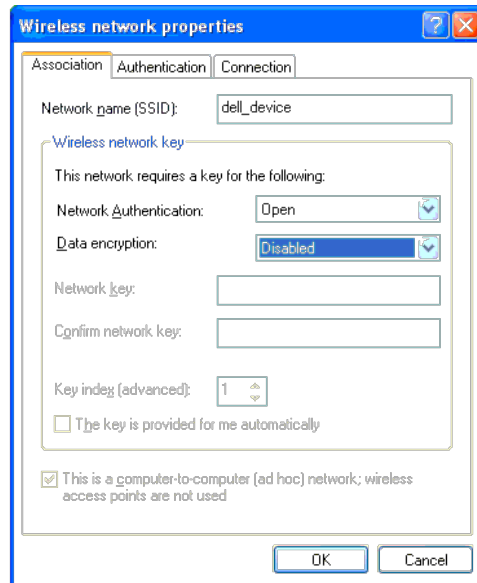

- i. Click the **Move up** button to move the newly added SSID to the top of the list.
- j. Click **OK** to close the **Property** dialog box.

 **NOTE:** When your operating system is earlier than Windows 2000, create settings according to the manual of the wireless settings tool provided by your wireless device manufacturer.

**For Windows Vista:**

- a. Open **Control Panel**.
- b. Select **Network and Internet**.
- c. Select **Network and Sharing Center**.
- d. Select **Connect to a network**.
- e. Select **dell\_device** from the network items listed in **Connect to a network**.
- f. Select **Connect Anyway** in the warning dialog box indicating you are entering an unsecured area.
- g. Click **Close** in the dialog box after confirming the connection is a success.

**For Windows Server 2008:**

- a. Open **Control Panel**.
- b. Select **Network and Sharing Center**.
- c. Select **Connect to a network**.
- d. Select **dell\_device** from the network items listed in **Connect to a network**.
- e. Select **Connect Anyway** in the warning dialog box indicating you are entering an unsecured area.
- f. Click **Close** in the dialog box after confirming the connection is a success.

**For Windows Server 2008 R2 and Windows 7:**

- a. Open **Control Panel**.
- b. Select **Network and Internet**.

- c. Select **Network and Sharing Center**.
  - d. Select **Connect to a network**.
  - e. Select **dell\_device** from the network items listed in the available network list, and click **Connect**.
2. Check the IP address assigned by AutoIP on the printer.
- a. Press **Menu** on the printer control panel.
  - b. Scroll down and select **Admin Menu**.
  - c. Scroll down and select **Network**.
  - d. Scroll down and select **TCP/IP**.
  - e. Scroll down and select **IPv4**.
  - f. Scroll down and select **IP Address**.  
(Default IP address range: 169.254.xxx.yyy)

IP Address
169.254.000.041*

3. Check that the IP address on your computer is assigned by DHCP.

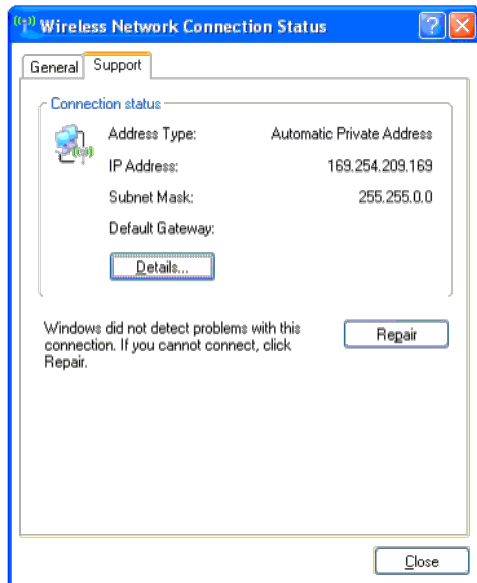

4. Open Dell Printer Configuration Web Tool using WEB browser.

5. Create wireless setting of the printer on Dell Printer Configuration Web Tool.
6. Reboot the printer.
7. Restore the wireless setting on your computer.

**NOTE:** If your computer provides a wireless printer adapter tool, change the wireless settings using this tool. Or you can change the wireless settings using the tool provided by the operating system. See the instructions below.

**For Windows XP and Windows Server 2003:**

- a. Select **Network Connections** from Control Panel.
- b. Right-click **Wireless Network Connection** and select **Properties**.
- c. Select **Wireless Network** tab.
- d. Ensure the check box for **Use Windows to configure my wireless network settings** is checked.
- e. Click **Advanced**.
- f. Do either of the following:

*When wireless ad-hoc mode is set to the printer:*

Select **Computer to Computer (ad hoc) networks only** and close the **Advanced** dialog box.

*When wireless infrastructure mode is set to the printer:*

Select **Access point (Infrastructure) networks only** and close the **Advanced** dialog box.

- g. Click **Add** to display **Wireless network properties**.
- h. Enter the setting that you send to printer and click **OK**.
- i. Click **Move up** to move the setting to the top of the list.
- j. Click **OK** to close the **Property** dialog box.

 **NOTE:** When your operating system is earlier than Windows 2000, create settings according to the manual of the wireless settings tool provided by your wireless device manufacturer.

#### For Windows Vista:

- a. Open **Control Panel**.
- b. Select **Network and Internet**.
- c. Select **Network and Sharing Center**.
- d. Select **Connect to a network**.
- e. Select the setting you send to the printer from the network items listed in **Connect to a network**.
- f. Select **Connect Anyway** in the warning dialog box indication indicating you are entering an unsecured area.
- g. Click **Close** in the dialog box after confirming the connection is a success.

#### For Windows Server 2008:

- a. Open **Control Panel**.
- b. Select **Network and Sharing Center**.
- c. Select **Connect to a network**.
- d. Select the setting you send to the printer from the network items listed in **Connect to a network**.
- e. Select **Connect Anyway** in the warning dialog box indication indicating you are entering an unsecured area.
- f. Click **Close** in the dialog box after confirming the connection is a success.

#### For Windows Server 2008 R2 and Windows 7:

- a. Open **Control Panel**.
- b. Select **Network and Internet**.
- c. Select **Network and Sharing Center**.
- d. Select **Connect to a network**.
- e. Select the setting you send to the printer from the network items listed in the available network list, and click **Connect**.
- f. Enter the **Security key** and click **OK**, if necessary.

#### For Fixed IP network:

1. Create wireless setting of your computer following the steps below.

 **NOTE:** If your computer provides a wireless printer adapter tool, change the wireless settings using this tool. Or you can change the wireless settings using the tool provided by the operating system. See the instructions below.

#### For Windows XP and Windows Server 2003:

- a. Select **Network Connections** from Control Panel.
- b. Right-click **Wireless Network Connection** and select **Properties**.
- c. Select the **Wireless Networks** tab.
- d. Ensure the check box for **Use Windows to configure my wireless network settings** is checked.

 **NOTE:** Be sure to write down the current wireless computer settings in steps d and f so that you can restore them later.

- e. Click the **Advanced** button.

- f. Select **Computer to Computer (ad hoc) networks only** and close the **Advanced** dialog box.
- g. Click the **Add** button to display **Wireless network properties**.
- h. Under the **Association** tab, enter the following information and click **OK**.

Network name (SSID): dell\_device

Network Authentication: Open

Data encryption: Disabled

Ad hoc network: checked

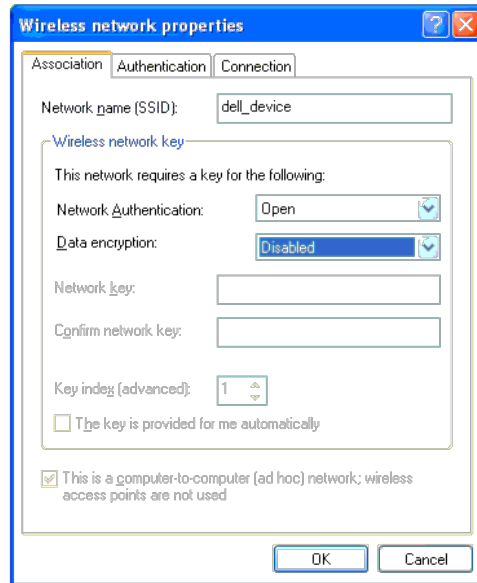

- i. Click the **Move up** button to move the newly added SSID to the top of the list.
- j. Click **OK** to close the **Property** dialog box.

 **NOTE:** When your operating system is earlier than Windows 2000, create settings according to the manual of the wireless settings tool provided by your wireless device manufacturer.

#### For Windows Vista:

- a. Open **Control Panel**.
- b. Select **Network and Internet**.
- c. Select **Network and Sharing Center**.
- d. Select **Connect to a network**.
- e. Select **dell\_device** from the network items listed in **Connect to a network**.
- f. Select **Connect Anyway** in the warning dialog box indicating you are entering an unsecured area.
- g. Click **Close** in the dialog box after confirming the connection is a success.

#### For Windows Server 2008:

- a. Open **Control Panel**.
- b. Select **Network and Sharing Center**.
- c. Select **Connect to a network**.
- d. Select **dell\_device** from the network items listed in **Connect to a network**.
- e. Select **Connect Anyway** in the warning dialog box indicating you are entering an unsecured area.

f. Click **Close** in the dialog box after confirming the connection is a success.

**For Windows Server 2008 R2 and Windows 7:**

- a. Open **Control Panel**.
  - b. Select **Network and Internet**.
  - c. Select **Network and Sharing Center**.
  - d. Select **Connect to a network**.
  - e. Select **dell\_device** from the network items listed in the available network list, and click **Connect**.
2. Check the IP address on your computer.

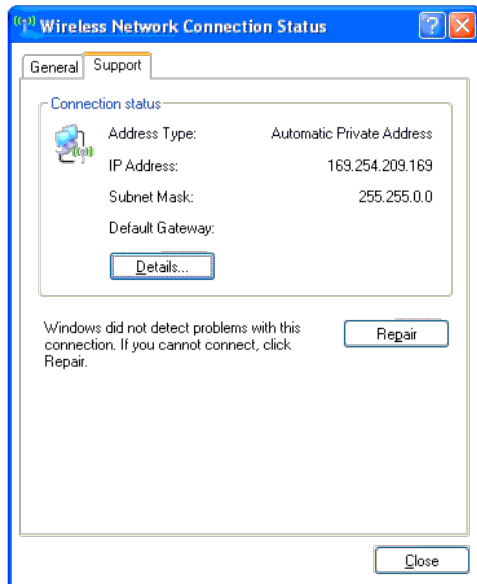

3. Set the IP address on the printer.
- a. Press **Menu** button.
  - b. Scroll to **Admin** menu.
  - c. Select **Network**.
  - d. Select **TCP/IP**.
  - e. Select **Get IP Address**.
  - f. Select **Panel**.
  - g. Scroll back to **IP Address**.
  - h. Manually enter the IP address using the directional buttons on the control panel and press enter button.

IP Address 172.031.000.041*
--------------------------------

4. Open Dell Printer Configuration Web Tool using WEB browser.



5. Change the wireless setting of the printer on Dell Printer Configuration Web Tool.
6. Reboot the printer.
7. Restore the wireless setting on your computer.

**NOTE:** If your computer provides a wireless printer adapter tool, change the wireless settings using this tool. Or you can change the wireless settings using the tool provided by the operating system. See the instructions below.

**For Windows XP and Windows Server 2003:**

- a. Select **Network Connections** from Control Panel.
- b. Right-click **Wireless Network Connection** and select **Properties**.
- c. Select **Wireless Network** tab.
- d. Ensure the check box for **Use Windows to configure my wireless network settings** is checked.
- e. Click **Advanced**.
- f. Do either of the following:

*When wireless ad-hoc mode is set to the printer:*

Select **Computer to Computer (ad hoc) networks only** and close the **Advanced** dialog box.

*When wireless infrastructure mode is set to the printer:*

Select **Access point (Infrastructure) networks only** and close the **Advanced** dialog box.

- g. Click **Add** to display **Wireless network properties**.
- h. Enter the setting that you send to printer and click **OK**.
- i. Click **Move up** to move the setting to the top of the list.
- j. Click **OK** to close the **Property** dialog box.

 **NOTE:** When your operating system is earlier than Windows 2000, create settings according to the manual of the wireless settings tool provided by your wireless device manufacturer.

**For Windows Vista:**

- a. Open **Control Panel**.
- b. Select **Network and Internet**.
- c. Select **Network and Sharing Center**.
- d. Select **Connect to a network**.
- e. Select the setting you send to the printer from the network items listed in **Connect to a network**.
- f. Select **Connect Anyway** in the warning dialog box indication indicating you are entering an unsecured area.
- g. Click **Close** in the dialog box after confirming the connection is a success.

**For Windows Server 2008:**

- a. Open **Control Panel**.
- b. Select **Network and Sharing Center**.
- c. Select **Connect to a network**.
- d. Select the setting you send to the printer from the network items listed in **Connect to a network**.
- e. Select **Connect Anyway** in the warning dialog box indication indicating you are entering an unsecured area.
- f. Click **Close** in the dialog box after confirming the connection is a success.

**For Windows Server 2008 R2 and Windows 7:**

- a. Open **Control Panel**.
- b. Select **Network and Internet**.
- c. Select **Network and Sharing Center**.
- d. Select **Connect to a network**.
- e. Select the setting you send to the printer from the network items listed in the available network list, and click **Connect**.
- f. Enter the **Security key** and click **OK**, if necessary.

## Wireless Setting through Dell Printer Configuration Web Tool - Advanced setup

### Access point (Infrastructure, DHCP network)

1. Create new wireless settings for your computer.

 **NOTE:** If your computer provides a wireless printer adapter tool, change the wireless settings using this tool. Or you can change the wireless settings using the tool provided by the operating system. See the instructions below.

**For Windows XP and Windows Server 2003:**

- a. Select **Network Connections** from Control Panel.
- b. Right-click **Wireless Network Connection** and select **Properties**.
- c. Select the **Wireless Networks** tab.
- d. Ensure the check box for **Use Windows to configure my wireless network settings** is checked.

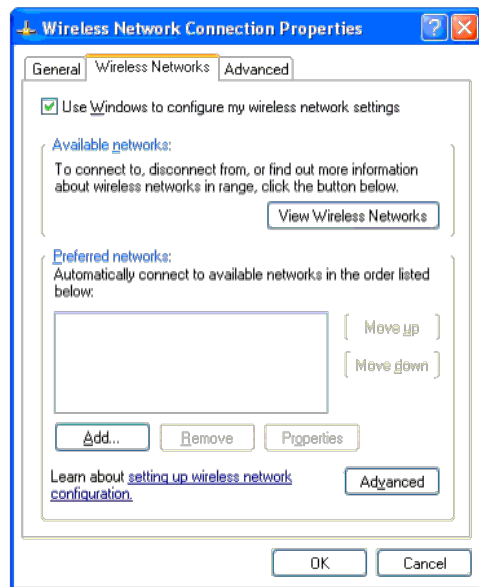

**NOTE:** Be sure to write down the current wireless computer settings in steps d and g so that you can restore them later.

- e. Click the **Advanced** button.
- f. Select **Computer to Computer (ad hoc) networks only** and close the **Advanced** dialog box.
- g. Click the **Add** button to display **Wireless network properties**.
- h. Under the **Association** tab, enter the following information and click **OK**.

Network name (SSID): dell\_device

Network Authentication: Open

Data encryption: Disabled

Ad hoc network: checked

- i. Click the **Move up** button to move the newly added SSID to the top of the list.
- j. Click **OK** to close the **Property** dialog box.

**NOTE:** When your operating system is earlier than Windows 2000, create settings according to the manual of the wireless settings tool provided by your wireless device manufacturer.

#### For Windows Vista:

- a. Open **Control Panel**.
- b. Select **Network and Internet**.
- c. Select **Network and Sharing Center**.
- d. Select **Connect to a network**.
- e. Select **dell\_device** from the network items listed in **Connect to a network**.
- f. Select **Connect Anyway** in the warning dialog box indicating you are entering an unsecured area.
- g. Click **Close** in the dialog box after confirming the connection is a success.

#### For Windows Server 2008:

- a. Open **Control Panel**.
- b. Select **Network and Sharing Center**.
- c. Select **Connect to a network**.

- d. Select **dell\_device** from the network items listed in **Connect to a network**.
- e. Select **Connect Anyway** in the warning dialog box indicating you are entering an unsecured area.
- f. Click **Close** in the dialog box after confirming the connection is a success.

**For Windows Server 2008 R2 and Windows 7:**

- a. Open **Control Panel**.
- b. Select **Network and Internet**.
- c. Select **Network and Sharing Center**.
- d. Select **Connect to a network**.
- e. Select **dell\_device** from the network items listed in the available network list, and click **Connect**.

2. Set up the printer wireless adapter IP address.

- a. Reset the settings for the wireless adapter to the default.
  - i. Press **Menu** on printer control panel.
  - ii. Scroll down and select **Admin Menu**.
  - iii. Scroll down and select **Network**.
  - iv. Scroll down and select **Reset Wireless**.
  - v. Restart the printer.
- b. Retrieve the wireless adapter IP address on the printer.

- i. Press **Menu** on the printer control panel.
- ii. Scroll down and select **Admin Menu**.
- iii. Scroll down and select **Network**.
- iv. Scroll down and select **TCP/IP**.
- v. Scroll down and select **IPv4**.
- vi. Scroll down and select **IP Address**.

(Default IP address range: 169.254.xxx.yyy)

IP Address 169.254.000.041*
--------------------------------

3. Access Dell Printer Configuration Web Tool on your computer browser.

- a. Assign the PC IP address by DHCP mode (Change the TCP/IP properties to obtain the IP address automatically).
- b. Ensure your computer has the same IP address range as the printer wireless adapter.
  - e.g. 169.254.xxx.zzz
- c. Access the Dell Printer Configuration Web Tool using the WEB browser, and then type printer wireless adapter settings in the address field of the browser.
  - e.g. <http://169.254.xxx.yyy/> (Your wireless adapter IP address)
- d. Change wireless settings (SSID/ communication mode) from Dell Printer Configuration Web Tool.
  - i. Click **Print Server Settings** on the left navigational bar.
  - ii. Click the **Print Server Settings** tab.
  - iii. Click the **TCP/IP** sub-tab.
  - iv. Select **DHCP**.
  - v. Click the **Apply New Setting** button without restarting the printer (Ignore the screen instructions to restart the printer).

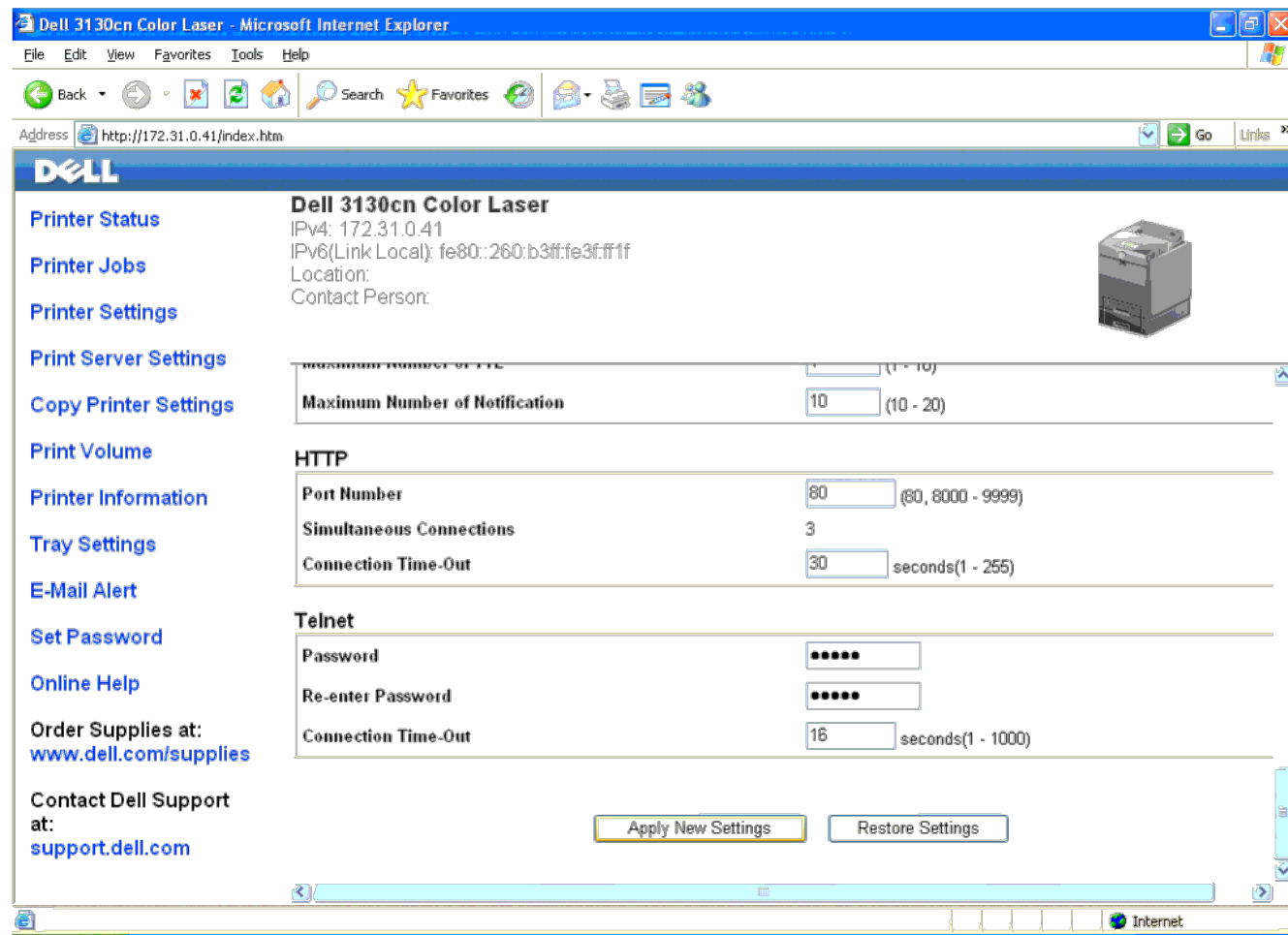

- vi. Click the **Wireless LAN** sub-tab.
  - vii. Change the **SSID** setting (according to your Access point SSID) and change **Network Type** to **Infrastructure**.
  - viii. Click the **Apply new settings** button.
4. Once printer wireless adapter is properly configured, you may use the typical network printer installation method to complete driver installation.
  5. To communicate with printer, you need to restore the previous wireless settings on your computer.
  6. Restore the previous wireless settings for your computer.

**NOTE:** If your computer provides a wireless printer adapter tool, change the wireless settings using this tool. Or you can change the wireless settings using the tool provided by the operating system. See the instructions below.

**For Windows XP and Windows Server 2003:**

- a. Select **Network Connections** from Control Panel.
- b. Right-click **Wireless Network Connection** and select **Properties**.
- c. Select the **Wireless Network** tab.
- d. Click the **Advanced** button.
- e. Select **Access point (Infrastructure) networks only** and close the **Advanced** dialog box (Applicable to printer with the wireless infrastructure mode).
- f. Select the setting that you send to the printer in the list in the **Preferred Network** group.

- g. Click **Move up** to move the setting to the top of the list.
- h. Click **OK** to close the **Property** dialog box.

 **NOTE:** When your operating system is earlier than Windows 2000, create settings according to the manual of the wireless settings tool provided by your wireless device manufacturer.

**For Windows Vista:**

- a. Open **Control Panel**.
- b. Select **Network and Internet**.
- c. Select **Network and Sharing Center**.
- d. Select **Connect to a network**.
- e. Select the setting you send to the printer from the network items listed in **Connect to a network**.
- f. Select **Connect Anyway** in the warning dialog box indication indicating you are entering an unsecured area.
- g. Click **Close** in the dialog box after confirming the connection is a success.

**For Windows Server 2008:**

- a. Open **Control Panel**.
- b. Select **Network and Sharing Center**.
- c. Select **Connect to a network**.
- d. Select the setting you send to the printer from the network items listed in **Connect to a network**.
- e. Select **Connect Anyway** in the warning dialog box indication indicating you are entering an unsecured area.
- f. Click **Close** in the dialog box after confirming the connection is a success.

**For Windows Server 2008 R2 and Windows 7:**

- a. Open **Control Panel**.
- b. Select **Network and Internet**.
- c. Select **Network and Sharing Center**.
- d. Select **Connect to a network**.
- e. Select the setting you send to the printer from the network items listed in the available network list, and click **Connect**.
- f. Enter the **Security key** and click **OK**, if necessary.

## Access point (Infrastructure, Fixed IP network)

1. Ensure that the addresses of your computer and access point is in the same IP range. Match the subnet mask and gateway addresses of your computer to the access point settings.
2. Create new wireless settings of your computer by following the steps below.

 **NOTE:** If your computer provides a wireless printer adapter tool, change the wireless settings using this tool. Or you can change the wireless settings using the tool provided by the operating system. See the instructions below.

**For Windows XP and Windows Server 2003:**

- a. Select **Network Connections** from Control Panel.
- b. Right-click **Wireless Network Connection** and select **Properties**.
- c. Select the **Wireless Networks** tab.
- d. Ensure the check box for **Use Windows to configure my wireless network settings** is checked.

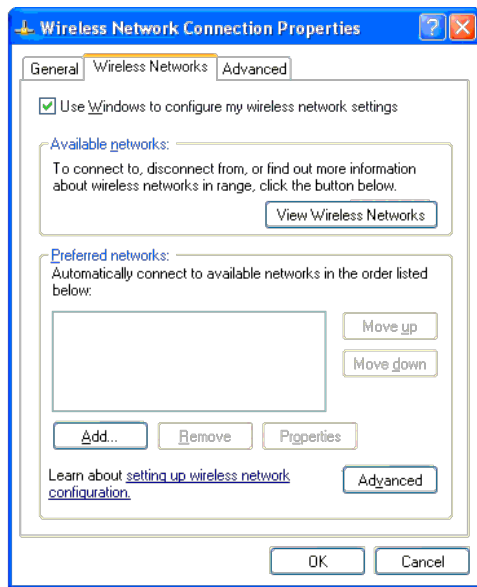

 **NOTE:** Be sure to write down the current wireless computer settings in steps d and f so that you can restore them later.

- e. Click the **Advanced** button.
- f. Select **Computer to Computer (ad hoc) networks only** and close the **Advanced** dialog box.
- g. Click the **Add** button to display **Wireless network properties**.
- h. Under the **Association** tab, enter the following information and click **OK**.

Network name (SSID): dell\_device

Network Authentication: Open

Data encryption: Disabled

Ad hoc network: Checked

- i. Click the **Move up** button to move the newly added SSID to the top of the list.
- j. Click **OK** to close the **Property** dialog box.

 **NOTE:** When your OS is earlier than Windows 2000, create settings according to the manual of the wireless settings tool provided by your wireless device manufacturer.

#### For Windows Vista:

- a. Open **Control Panel**.
- b. Select **Network and Internet**.
- c. Select **Network and Sharing Center**.
- d. Select **Connect to a network**.
- e. Select **dell\_device** from the network items listed in **Connect to a network**.
- f. Select **Connect Anyway** in the warning dialog box indicating you are entering an unsecured area.
- g. Click **Close** in the dialog box after confirming the connection is a success.

#### For Windows Server 2008:

- a. Open **Control Panel**.
- b. Select **Network and Sharing Center**.
- c. Select **Connect to a network**.

- d. Select **dell\_device** from the network items listed in **Connect to a network**.
- e. Select **Connect Anyway** in the warning dialog box indicating you are entering an unsecured area.
- f. Click **Close** in the dialog box after confirming the connection is a success.

**For Windows Server 2008 R2 and Windows 7:**

- a. Open **Control Panel**.
- b. Select **Network and Internet**.
- c. Select **Network and Sharing Center**.
- d. Select **Connect to a network**.
- e. Select **dell\_device** from the network items listed in the available network list, and click **Connect**.

3. Check the IP, subnet mask and gateway address on your computer.

e.g. IP: 192.168.1.1

Subnet mask: 255.255.0.0

4. Set the IP address from the printer control panel to be in the same range as that of your computer. Match the subnet mask and gateway addresses of the printer to your computer settings.

- a. Press **Menu** button.
- b. Scroll to **Admin** menu.
- c. Select **Network**.
- d. Select **TCP/IP**.
- e. Select **Get IP Address**.
- f. Select **Panel**.
- g. Scroll back to **IP Address**.
- h. Manually enter the IP address using the directional buttons on the control panel and press enter button.

IP Address

172.031.000.041\*

- i. Scroll back to **Subnet Mask**.
- j. Manually enter the subnet mask address using the directional buttons on the control panel and press enter button.
- k. Scroll back to **Gateway Address**.
- l. Manually enter the gateway address using the directional buttons on the control panel and press the Enter button.
- m. Restart the printer.

5. Open Dell Printer Configuration Web Tool using the WEB browser.

e.g.: <http://192.168.1.2>

6. Change wireless settings of the printer from Dell Printer Configuration Web Tool.

- a. Click **Print Server Settings** on the left navigational bar.
- b. Click **Print Server Settings** tab.
- c. Click **Wireless LAN** sub-tab.
- d. Change the SSID setting (according to your access point SSID) and change **Network Type** to **Infrastructure**.
- e. Click the **Apply new settings** button.



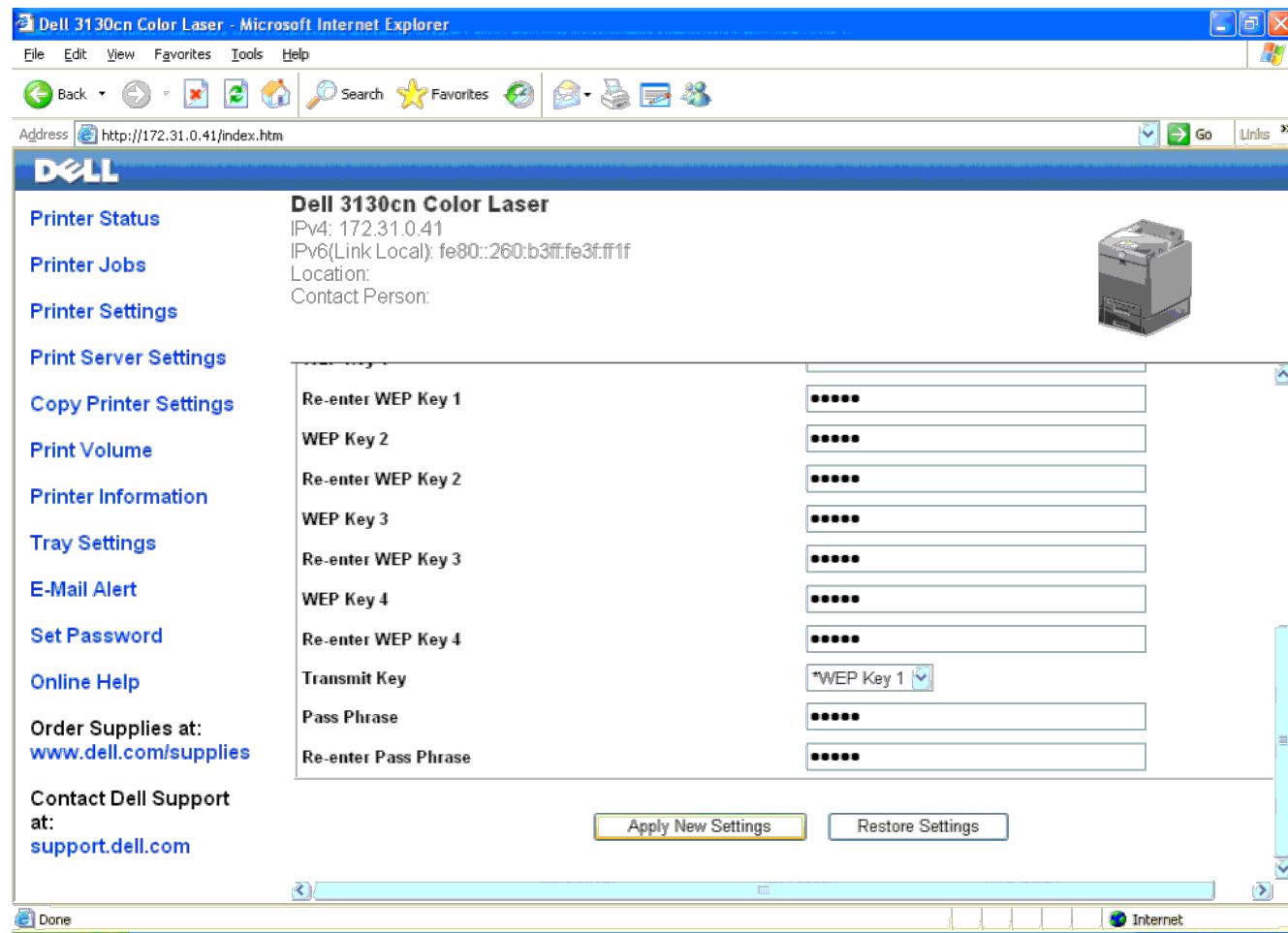

7. Restore the previous wireless settings for your computer.

**NOTE:** If your computer provides a wireless printer adapter tool, change the wireless settings using this tool. Or you can change the wireless settings using the tool provided by the operating system. See the instructions below.

**For Windows XP and Windows Server 2003:**

- a. Select **Network Connections** from Control Panel.
- b. Right-click **Wireless Network Connection** and select **Properties**.
- c. Select **Wireless Network** tab.
- d. Click **Advanced**.
- e. Do either of the following:
  - When wireless ad-hoc mode is set to the printer:  
Select **Computer to Computer (ad hoc) networks only** and close the **Advanced** dialog box.
  - When wireless infrastructure mode is set to the printer:  
Select **Access point (Infrastructure) networks only** and close the **Advanced** dialog box.
- f. Select the setting that you send to the printer in the list in **Preferred Network** group.
- g. Click **Move up** to move the setting to the top of the list.

**For Windows Vista:**

- a. Open **Control Panel**.
- b. Select **Network and Internet**.
- c. Select **Network and Sharing Center**.
- d. Select **Connect to a network**.
- e. Select the setting you send to the printer from the network items listed in **Connect to a network**.
- f. Select **Connect Anyway** in the warning dialog box indication indicating you are entering an unsecured area.
- g. Click **Close** in the dialog box after confirming the connection is a success.

**For Windows Server 2008:**

- a. Open **Control Panel**.
- b. Select **Network and Sharing Center**.
- c. Select **Connect to a network**.
- d. Select the setting you send to the printer from the network items listed in **Connect to a network**.
- e. Select **Connect Anyway** in the warning dialog box indication indicating you are entering an unsecured area.
- f. Click **Close** in the dialog box after confirming the connection is a success.

**For Windows Server 2008 R2 and Windows 7:**

- a. Open **Control Panel**.
  - b. Select **Network and Internet**.
  - c. Select **Network and Sharing Center**.
  - d. Select **Connect to a network**.
  - e. Select the setting you send to the printer from the network items listed in the available network list, and click **Connect**.
  - f. Enter the **Security key** and click **OK**, if necessary.
8. Click **OK** to close the **Property** dialog box.

 **NOTE:** When your operating system is earlier than Windows 2000, create settings according to the manual of the wireless settings tool provided by your wireless device manufacturer.

## Enable Network Discovery and File Sharing for all Public Networks

You can skip "Disable User Account Control" for this procedure.

 **NOTE:** This step is required when you use Windows Vista, Windows Server 2008, Windows Server 2008 R2, or Windows 7 for the server computer.

1. Click **Start® Network** (**Start®** your user name® **Network** for Windows 7).
2. Click **Network discovery and file sharing are turned off. Network computers and devices are not visible. Click to change**.
3. Click **Turn on network discovery and file sharing**.
4. Click **Yes, turn on network discovery and file sharing for all public networks**.

# Print Media Guidelines

- [Paper](#)
- [Transparencies](#)
- [Envelopes](#)
- [Labels](#)
- [Storing Print Media](#)
- [Identifying Print Media Sources and Specifications](#)

Print media is paper, labels, envelopes, and coated paper among others. Your printer provides high-quality printing on a variety of print media. Selecting the appropriate print media for your printer helps avoid printing troubles. This section describes selecting print media, caring for print media, and loading the print media in the tray 1 or optional 550 sheet feeder.

---

## Paper

For the best print quality in color, use 75 g/m<sup>2</sup> (20 lb) xerographic, grain long paper. For the best print quality in black and white, use 90 g/m<sup>2</sup> (24 lb) xerographic, grain long paper. It is recommended that you try a sample first before buying large quantities of any print media.

When loading paper, identify the recommended print side on the paper package, and load the paper accordingly. See "[Loading Print Media in the Standard and Optional Trays](#)" and "[Loading the MPF](#)" for detailed loading instructions.

## Paper Characteristics

The following paper characteristics affect print quality and reliability. It is recommended that you follow these guidelines when evaluating new paper stock.

### Weight

The tray automatically feeds paper weights from 60 to 216 g/m<sup>2</sup> (16 to 80 lb bond) grain long. The multipurpose feeder (MPF) automatically feeds paper weights from 60 to 216 g/m<sup>2</sup> (16 to 80 lb bond) grain long. Paper lighter than 60 g/m<sup>2</sup> (16 lb) may not feed properly, and could cause paper jams. For best performance, use 75 g/m<sup>2</sup> (20 lb bond) grain long paper.

### Curl

Curl is the tendency of print media to curve at its edges. Excessive curl can cause paper feeding problems. Curl usually occurs after the paper passes through the printer, where it is exposed to high temperatures. Storing paper unwrapped, even in the paper tray, can contribute to paper curling prior to printing and cause feeding problems regardless of humidity. When printing on curled paper, straighten the paper and then insert it into the MPF.

### Smoothness

The degree of paper smoothness directly affects print quality. If the paper is too rough, the toner does not fuse to the paper properly, resulting in poor print quality. If the paper is too smooth, it can cause paper feeding problems. Smoothness between 150 and 250 Sheffield points produces the best print quality.

### Moisture Content

The amount of moisture in the paper affects both print quality and the ability of the printer to feed the paper properly.

Leave the paper in its original packaging until you are ready to use it. This limits the exposure of the paper to moisture changes that can degrade its performance.

## Grain Direction

Grain refers to the alignment of the paper fibers in a sheet of paper. Grain is either grain long, running the length of the paper, or grain short, running the width of the paper. For 60 to 135 g/m<sup>2</sup> (16 to 36 lb bond) paper, grain long fibers are recommended. For paper heavier than 135 g/m<sup>2</sup> (36 lb bond), grain short is preferred.

## Fiber Content

Most high-quality xerographic paper is made from 100% chemically pulped wood. Paper containing fibers such as cotton possess characteristics that can result in degraded paper handling.

## Recommended Paper

To ensure the best print quality and feed reliability, use 75 g/m<sup>2</sup> (20 lb) xerographic paper. Business paper designed for general business use also provide acceptable print quality. Only use paper able to withstand high temperatures without discoloring, bleeding, or releasing hazardous emissions. The laser printing process heats paper to high temperatures. Check with the manufacturer or vendor to determine whether the paper you have chosen is acceptable for laser printers.

Always print several samples before buying large quantities of any type of print media. When choosing any print media, you should consider the weight, fiber content, and color.

## Unacceptable Paper

The following paper types are not recommended for use with the printer:

- Chemically treated paper used to make copies without carbon paper, also known as carbonless paper, carbonless copy paper (CCP), or no carbon required (NCR) paper
- Preprinted paper with chemicals that may contaminate the printer
- Preprinted paper that can be affected by the temperature in the fuser
- Preprinted paper that require a registration (the precise print location on the page) greater than ±0.09 inches, such as optical character recognition (OCR) forms

In some cases, you can adjust registration with your software program to successfully print on these forms.

- Coated paper (erasable bond), synthetic paper, thermal paper
- Rough-edged, rough or heavily textured surface paper, or curled paper
- Recycled paper containing more than 25% post-consumer waste that do not meet DIN 19 309
- Multiple-part forms or documents
- Print quality may deteriorate (blank spaces or blotches may appear in the text) when printing on talc or acid paper.

## Selecting Paper

Proper paper selection helps prevent jams and ensures trouble-free printing.

To help avoid jams or poor print quality:

- Always use new, undamaged paper.
- Before loading the paper, identify the recommended print side of the paper. This information is usually indicated on the paper package.

- Do not use paper that you have cut or trimmed yourself.
- Do not mix print media sizes, weights, or types in the same source. This may result in a paper jam.
- Do not remove the tray while a job is printing.
- Ensure that the paper is properly loaded in the tray.
- Flex paper back and forth, and then fan them. Straighten the edges of the stack on a level surface.

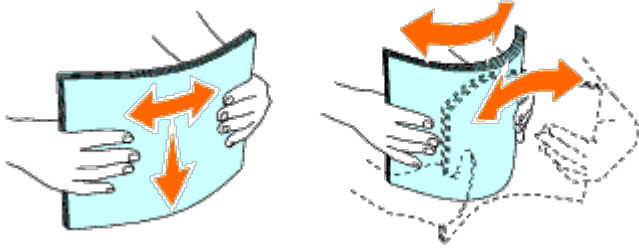

## Selecting Pre-Printed Media and Letterheads

When selecting pre-printed and letterhead paper for the printer:

- Use grain long paper for best results.
- Use only forms and letterheads printed using an offset lithographic or engraved printing process.
- Select paper that absorb ink, but does not bleed.
- Avoid paper with rough or heavily textured surfaces.
- Use paper printed with heat-resistant inks designed for use in xerographic copiers. The ink must withstand temperatures of 225 °C (437 °F) without melting or releasing hazardous emissions.
- Use inks that are not affected by the resin in the toner or the silicone in the fuser. Inks that are oxidation-set or oil-based should meet these requirements; latex inks might not. If you are in doubt, contact your paper supplier.

## Printing on a Letterhead (Pre-Printed and Pre-Punched Paper)

Check with the manufacturer or vendor to determine whether the pre-printed letterhead that you have selected is acceptable for laser printers.

Page orientation is important when printing on pre-printed paper such as letterhead and pre-punched paper. The following table shows the orientation when loading letterheads in the tray or feeders. For other pre-printed and prepunched paper, load the paper by reference to the following table.

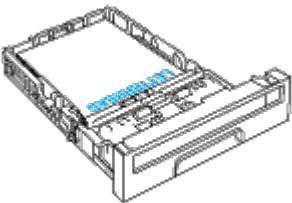
Print media source	Print side	Page orientation
Tray 1 550 sheet feeder	Face up 	Letterhead enters the printer last
MPF	Face down	Letterhead enters the printer first

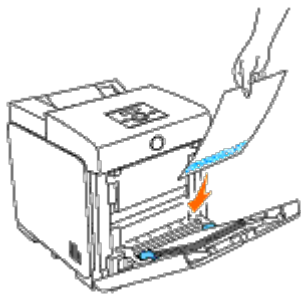

## Selecting Pre-Punched Paper

When selecting pre-punched paper for the printer:

- Test paper from several manufacturers before ordering and using large quantities of pre-punched paper.
- Paper should be punched at the paper manufacturer and not drilled into paper already packaged in a ream. Drilled paper can cause jams when multiple sheets feed through the printer. This may result in a paper jam.
- Pre-punched paper can include more paper dust than standard paper. Your printer may require more frequent cleaning and feed reliability may not be as good as standard paper.
- Weight guidelines for pre-punched paper are the same as non-punched paper.

---

## Transparencies

You can load up to 75 sheets of transparencies in the MPF for a single print job. It is recommended that you try a sample first before buying large quantities of any print media.

When printing on transparencies:

- Set the paper type to **Transparency** from the printer driver to avoid damaging your printer.
- Use transparencies designed specifically for laser printers. Do not use regular transparencies. Transparencies must be able to withstand temperatures of 205°C (401°F) without melting, discoloring, offsetting or releasing hazardous emissions.
- Avoid getting fingerprints on the transparencies. This may result in poor print quality.
- Before loading transparencies, fan the stack to prevent sheets from sticking together.
- Non-white transparencies are not supported with the printer.

## Selecting Transparencies

The printer can print directly on transparencies designed for use in laser printers. Print quality and durability depend on the transparency used. It is recommended that you try a sample first before buying large quantities of any print media.

The paper type setting for the MPF should be set to *Transparency* to help prevent jams. (See "[Tray Settings](#)" for detailed information about this setting.) Check with the manufacturer or vendor to determine whether your transparencies are compatible with laser printers that reach temperatures as high as 205°C (401°F). Only use transparencies that are able to withstand these temperatures without melting, discoloring, offsetting, or releasing hazardous emissions.

---

## Envelopes

Depending on the choice of envelopes, it is possible to expect variable levels of light wrinkling. It is recommended that you try a sample first before buying large quantities of any print media. See "[Loading the MPF](#)" for instructions on loading an envelope.

When printing on envelopes:

- Use only high-quality envelopes that are designed for use in laser printers.
  - Set the print media source to the MPF. Set the paper type to **Envelope**, and select the correct size of envelope from the printer driver.
  - For best performance, use envelopes made from 75 g/m<sup>2</sup> (20 lb bond) paper. You can use up to 105 g/m<sup>2</sup> (28 lb bond) weight for the envelope feeder as long as the cotton content is 25% or less. Envelopes with 100% cotton content must not exceed 90 g/m<sup>2</sup> (24 lb bond) weight.
  - Use only freshly unpackaged, undamaged envelopes.
  - Use envelopes that can withstand temperatures of 205°C (401°F) without sealing, excessive curling, wrinkling, or releasing hazardous emissions. If you have any doubts about the envelopes you are considering, check with the envelope supplier.
  - Adjust the guide to fit the width of the envelopes.
  - To load envelope in the MPF, insert the envelopes with the flaps closed and the short-edge of the envelopes facing into the printer. The print side must be facing down.
  - See "[Loading the MPF](#)" for instructions on loading an envelope.
  - Use one envelope size during a print job.
  - Ensure the humidity is low because high humidity (more than 60%) and the high printing temperatures may seal the envelopes.
  - For best performance, do not use envelopes that:
    - Have excessive curl or twist
    - Are stuck together or damaged in any way
    - Contain windows, holes, perforations, cutouts, embossing
    - Use metal clasps, string ties, or metal folding bars
    - Have an interlocking design
    - Have postage stamps attached
    - Have any exposed adhesive when the flap is in the sealed or closed position
    - Have nicked edges or bent corners
    - Have rough, cockle, or laid finishes
- 

## Labels

Your printer can print on many labels designed for use with laser printers. Label adhesives, face sheet (printable stock), and topcoats must be able to withstand temperatures of 205°C (401°F) and pressure of 25 pounds per square inch (psi). It is recommended that you try a sample first before buying large quantities of any print media.

When printing on labels:

- Set the paper type to **Label** from the printer driver.
- Do not load labels together with paper in the same tray. This may result in a jam.
- Do not use label sheets with a slick backing material.
- Do not print within 1 mm (0.04 inches) of the die cut.
- Use full label sheets. Partial sheets may cause labels to peel off during printing, resulting in a jam. Partial sheets also contaminate your printer and your cartridge with adhesive, and could void your printer and cartridge warranties.
- Use labels that can withstand temperatures of 205°C (401°F) without sealing, excessive curling, wrinkling, or releasing hazardous emissions.

- Do not print within 1 mm (0.04 inches) of the edge of the label, of the perforations, or between die-cuts of the label.
- Do not use label sheets that have adhesive to the edge of the sheet. It is recommended that zone coating of the adhesive is at least 1 mm (0.04 inches) away from edges. Adhesive material contaminates your printer and could void your warranty.
- If zone coating of the adhesive is not possible, a 3 mm (0.125 inches) strip should be removed on the leading and driver edge, and a non-oozing adhesive should be used.
- Remove a 3 mm (0.125 inches) strip from the leading edge to prevent labels from peeling inside the printer.
- Portrait orientation is preferred, especially when printing bar codes.
- Do not use labels that have exposed adhesive.

## Storing Print Media

For proper print media storage, the following guidelines help avoid media feeding problems and uneven print quality.

- For best results, store print media in an environment where the temperature is approximately 21°C (70°F) and the relative humidity is 40%.
- Store cartons of print media on a pallet or shelf, rather than directly on the floor.
- If you store individual packages of print media out of the original carton, ensure that they rest on a flat surface so that the edges do not buckle or curl.
- Do not place anything on top of the print media packages.

## Identifying Print Media Sources and Specifications

The following tables provide information on standard and optional print media sources.

### Supported Paper Sizes

	MPF	Tray 1	Optional 550 sheet feeder	Optional duplexer
A4 (210 x 297 mm)	Y*	Y*	Y*	Y*
A5 (148 x 210 mm)	Y	Y	Y	Y
B5 (182 x 257 mm)	Y	Y	Y	Y
Letter (8.5 x 11 in.)	Y	Y	Y	Y
Folio (8.5 x 13 in.)	Y	Y	Y	Y
Legal (8.5 x 14 in.)	Y	Y	Y	Y
Executive (7.25 x 10.5 in.)	Y	Y	Y	Y
Envelope #10 (4.125 x 9.5 in.)	Y	N	N	N
Monarch (3.875 x 7.5 in.)	Y	N	N	N
C5 (162 x 229 mm)	Y	N	N	N
DL (110 x 220 mm)	Y	N	N	N
Youkei size2 (162 x 114 mm)	Y	N	N	N
Youkei size3 (148 x 98 mm)	Y	N	N	N
Youkei size4 (235 x 105 mm)	Y	N	N	N
Youchoukei size3 (120 x 235 mm)	Y	N	N	N



Choukei size3 (120 x 235 mm)	Y	N	N	N
Japanese Post Card (100 x 148 mm)	Y	N	N	N
User-specified print size* <sup>4</sup>	Y* <sup>1</sup>	Y* <sup>2</sup>	Y* <sup>2</sup>	Y* <sup>3</sup>

\*<sup>1</sup> The tray supports user-specified print media that are 76.2 mm (3.00 in.) to 220 mm (8.66 in.) wide and 127 mm (5.00 in.) to 355.6 mm (14.00 in.) long.

\*<sup>2</sup> The tray supports user-specified print media that are 148.0 mm (5.83 in.) to 215.9 mm (8.50 in.) wide and 210 mm (8.27 in.) to 355.6 mm (14.00 in.) long.

\*<sup>3</sup> The duplexer supports user-specified print media that are 148.0 mm (5.83 in.) to 215.9 mm (8.50 in.) wide and 210 mm (8.27 in.) to 355.6 mm (14.00 in.) long.

\*<sup>4</sup> Only the administrator user can set the user-specified print size from the printer driver.

## Supported Paper Types

	MPF	Tray 1	Optional 550 sheet feeder	Optional duplexer
Plain (Light)	Y*	Y*	Y*	Y*
Plain (Normal)	Y	Y	Y	Y
Plain Thick	Y	Y	Y	Y
Covers	Y	Y	Y	Y
Covers Thick	Y	Y	Y	N
Coated Normal	Y	Y	Y	Y
Coated Thick	Y	Y	Y	N
Japanese Coated	Y	Y	Y	Y
Transparency	Y	N	N	N
Label Normal	Y	Y	Y	N
Label Thick	Y	Y	Y	N
Envelope	Y	N	N	N
Japanese Post Card	Y	N	N	N
Recycled	Y	Y	Y	Y
Letterhead	Y	Y	Y	Y
Preprinted	Y	Y	Y	Y
Prepunched	Y	Y	Y	Y
Color	Y	Y	Y	Y

\* Values marked by an asterisk (\*) are the factory default menu settings.

## Paper Type Specifications

Paper type	Weight (gsm)	Remarks
Plain Paper	60-80	-
Plain Thick Paper	81-105	-
Covers	106-162	-
Covers Thick	163-216	-
Coated Normal	106-162	Inkjet printer paper cannot be used.
Coated Thick	163-216	Inkjet printer paper cannot be used.

Japanese Coated	95-105	Inkjet printer paper cannot be used.
Transparency	-	Inkjet printer paper cannot be used.
Label Normal	-	Inkjet printer paper cannot be used.
Label Thick	-	Inkjet printer paper cannot be used.
Envelopes	-	-
Japanese Post Card	-	-
Recycled	-	-
Letterhead	-	-
Preprinted	64	-
Prepunched	64	-
Color	64	-

---

[Back to Contents Page](#)

# Loading Print Media

- [Standard and Optional Trays](#)
- [Loading Print Media in the Standard and Optional Trays](#)
- [MPF](#)
- [Loading the MPF](#)
- [Using the MPF](#)
- [Linking Trays](#)
- [Using the Duplex Function](#)
- [Using the Center Output Tray](#)
- [Using the Output Tray Extension](#)

Loading print media properly helps prevent jams and ensures trouble-free printing.

Before loading print media, identify the recommended print side of the print media. This information is usually on the print media package.

 **NOTE:** After loading paper in the tray, specify the same paper type on the operator panel.

---

## Standard and Optional Trays

### Capacity

The tray 1 can hold:

- 250 sheets of the standard paper.

The optional 550 sheet feeder can hold:

- 550 sheets of the standard paper.

### Print Media Dimensions

The standard and optional trays accept print media within the following dimensions:

- Width - 148 mm (5.83 inches) to 215.9 mm (8.5 inches)
  - Length - 210 mm (8.27 inches) to 355.6 mm (14.00 inches)
- 

## Loading Print Media in the Standard and Optional Trays

 **NOTE:** To avoid paper jams, do not remove the tray while a printing is in progress.

 **NOTE:** Use only laser print media. Do not use ink jet paper in this printer.

All trays are loaded the same way.

1. Pull the tray out of the printer until it stops. Hold the tray with both hands, lift the front slightly, and remove it from the printer.

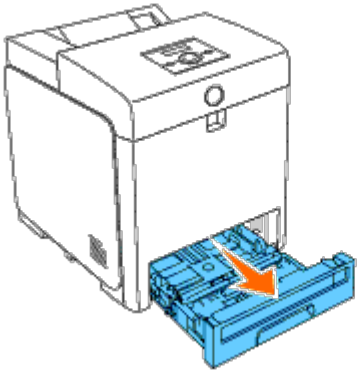

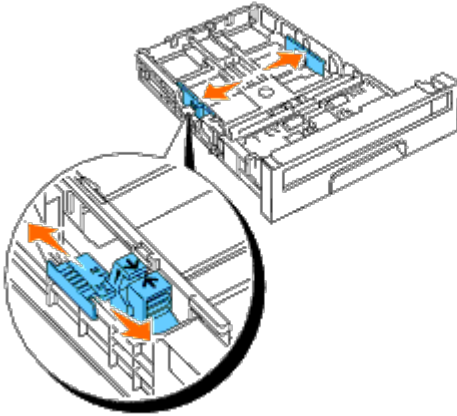

2. Slide the width guides to the edge of the tray. The width guides should be fully extended.

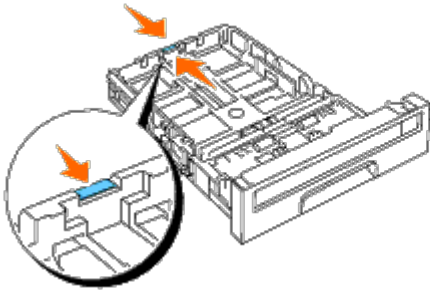

 **NOTE:** For Letter paper, push the lever to the 8.5" position.

3. Slide the tray to the size of the paper to be loaded by using the length guide.



 **NOTE:** When loading user-specified print media, fully extend the tray by squeezing the length guide at the back of the tray.

4. Before loading the print media, flex the sheets back and forth, and then fan them. Straighten the edges of the stack on a level surface.

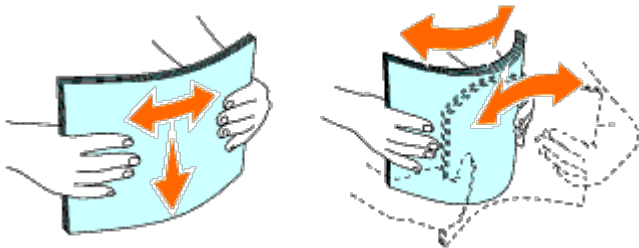

5. Place the print media into the tray with the recommended print side facing up.

 **NOTE:** Do not exceed the maximum fill line in the tray. Overfilling the tray may cause paper jams.

6. Adjust the width guides until they rest lightly against the edges of the stack of paper.

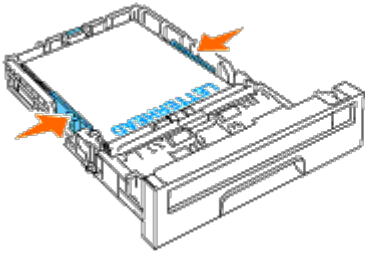

**NOTE:** When loading user-specified print media, adjust the width guides and slide the extendable part of the tray by squeezing the length guide and sliding it until it rests lightly against the edge of the stack of paper.

7. Insert the tray into the printer, and push until it stops.

8. Select the paper type from the operator panel if any print media other than plain print media is loaded. If a user-specified print media is loaded, you must specify the paper size setting by using the operator panel.

The letterhead must be toward the top edge of the standard tray or the optional feeder with the print side facing up. However, the letterhead must be inserted top edge first with the print side facing down when loading paper into the multipurpose feeder (MPF).

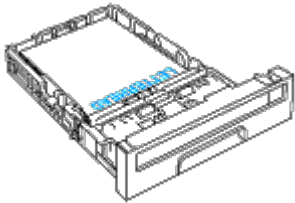
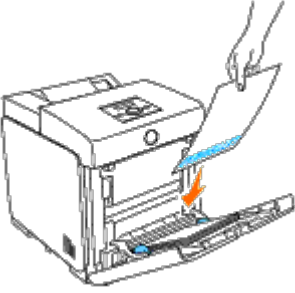
Print media source	Print side	Page orientation
Tray 1 550 sheet feeder	Face up 	Letterhead enters the printer last
MPF	Face down 	Letterhead enters the printer first

## MPF

## Capacity

The MPF can hold:

- 150 sheet of the standard paper.

## Print Media Dimensions

The MPF accepts print media within the following dimensions:

- Width - 76.2 mm (3.00 inches) to 220 mm (8.66 inches)
  - Length - 127 mm (5.00 inches) to 355.6 mm (14.00 inches)
- 

## Loading the MPF

In addition to plain paper, the MPF can be used various other sizes and types of print media such as envelopes, and transparencies.

1. Gently pull open the MPF cover.

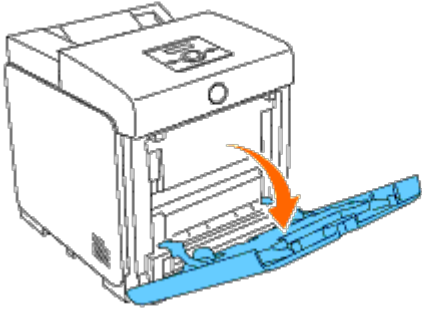

2. Slide the width guides to the edge of the tray. The width guides should be fully extended.

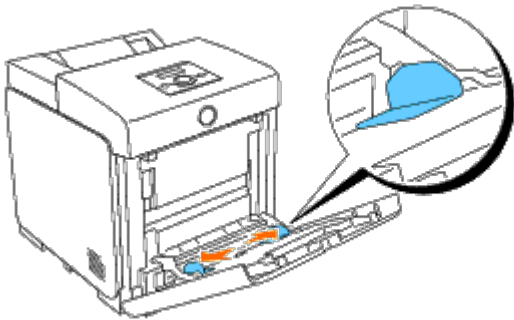

3. Insert all media facing down and top edge first into the MPF.

 **NOTE:** Do not force the print media into the single sheet feeder.

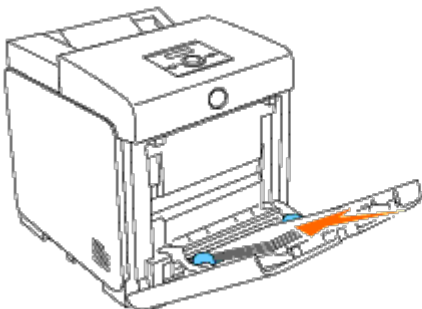

4. Slide both width guides until they rest lightly against the edge of the print media stack.

 **NOTE:** Do not force the print media into the single sheet feeder.

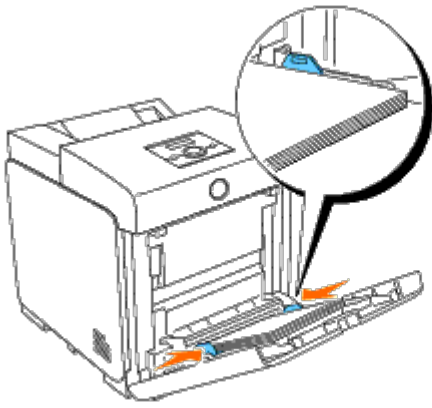

5. Ensure the type setting for the MPF is set to the correct value for the print media you have loaded.
6. Select print media source, size, and type in your software program and select the print media size and type on the printer operator panel.

## Loading an Envelope

To load envelopes in the MPF, insert the envelopes with the flaps closed and the short-edge of the envelopes facing into the printer. Orient the print side facing down and slide the envelope into the entry slot. You can load envelopes up to the maximum fill line in the tray at one time.

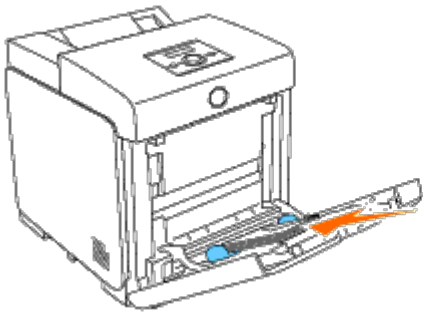

### When Loading Envelope# 10, Monarch, or DL

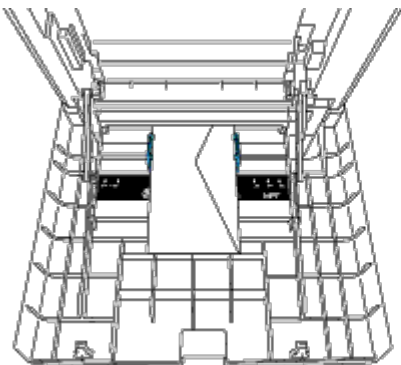

### When Loading C5

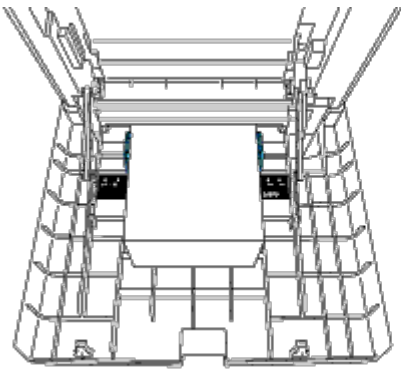

➡ **NOTICE:** Never use envelopes with windows, coated linings, or self-stick adhesives. These lead to paper jams and can cause damage to the printer.

✍ **NOTE:** Ensure that you load an envelope with the flap completely closed.

✍ **NOTE:** If you do not load envelopes in the MPF right after they have been removed from the packaging, they may bulge. To avoid jams, flatten them as shown below when loading them in the MPF.

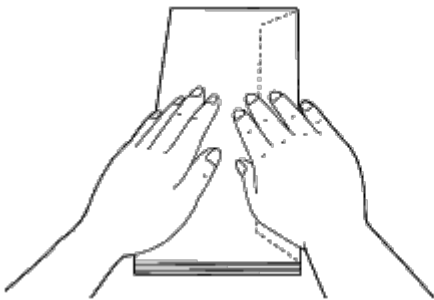

---

## Using the MPF

- Load only one size and type of print media during a single print job.
- To achieve the best possible print quality, use only high-quality print media that is designed for use in laser printers. For more guidelines on print media, see "[Print Media Guidelines](#)."
- Do not add or remove print media when there is still print media in the MPF or when the printer is printing from the MPF. This may result in a paper jam.
- Print media should be loaded with the recommended print side down and the top of the print media going into the MPF first.
- Do not place objects on the MPF. Also, avoid pressing down or applying excessive force on it.
- Do not remove any tray while a job is printing from the MPF or `Printing` is displayed on the operator panel. This may result in a paper jam.

The icons on the MPF identify how to load the MPF with paper, and how to turn an envelope for printing.



---

## Linking Trays

The printer automatically links the trays when you load the same size and type of print media in them. The first tray will be utilized until the media runs out after which the next tray will be used.

✍ **NOTE:** The print media should be the same size and type in each tray. The Multipurpose Feeder (MPF) cannot be linked to any of the tray sources.



After loading the selected trays with the same size and type of print media, select the **Paper Type** setting in the **Tray Settings** component for each source (tray).

To disable tray linking change the **Paper type** in one of the sources (trays) to a unique value.

 **NOTE:** If different types of print media of the same size are loaded in each tray, the printer will automatically link them if the paper type is not specified in the printer driver properties/preferences.

## Using the Duplex Function

Duplex printing (or two-sided printing) allows you to print on both sides of a sheet of paper. For sizes that are acceptable for duplex printing, see "[Supported Paper Sizes](#)." Duplex printing is only available when the optional duplexer is installed on the printer. For information on how to install the duplexer, see "[Installing a Duplexer](#)."

## Using Booklet Print

To use booklet print, you must select either **Flip on Short Edge** or **Flip on Long Edge** from the **Duplex** menu in the printer properties dialog box and then select **Booklet Creation** in the **Booklet/Poster/Mixed Document** dialog box displayed by clicking the **Booklet/Poster/Mixed Document** button. From the **Duplex** menu, you can define the way 2-sided print pages are bound, and how the printing on the back of the sheet (even-numbered pages) is oriented in relation to the printing on the front (odd-numbered pages).

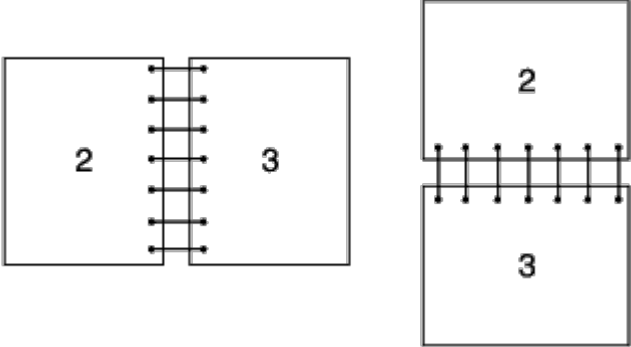
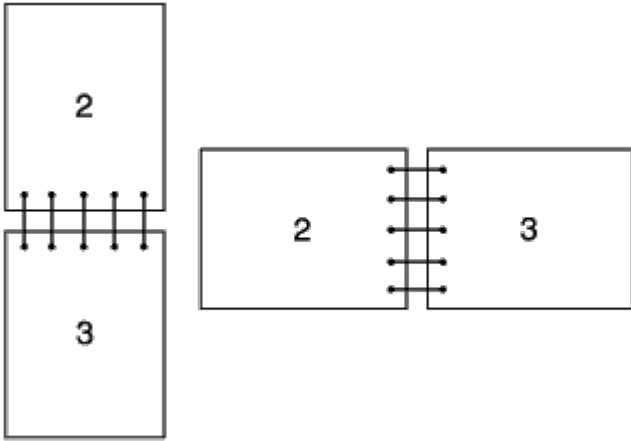
Flip on Long Edge	<p>Assumes binding along the long edge of the page (left edge for portrait orientation and top edge for landscape orientation). The following illustration shows long-edge binding for portrait and landscape pages:</p> 
Flip on Short Edge	<p>Assumes binding along the short edge of the page (top edge for portrait orientation and left edge for landscape orientation). The following illustration shows short-edge binding for portrait and landscape pages:</p> 

## Using the Center Output Tray

The center output tray holds up to:

- 250 sheets (20 lb (75 g/m<sup>2</sup>)) of plain paper
- 

## Using the Output Tray Extension

The output tray extension is designed to prevent print media from falling from the printer after the print job is complete.

Before printing a document, ensure the output tray extension is fully extended.

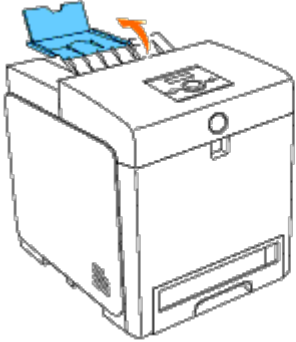

---

[Back to Contents Page](#)

# Operator Panel

- [Using the Operator Panel Buttons](#)
- [Printing a Panel Settings Page](#)

---

## Using the Operator Panel Buttons

The operator panel has a 2-line by 16-character liquid crystal display (LCD), seven buttons, and two indicators that flash when the printer is ready to print, and when an error occurs.

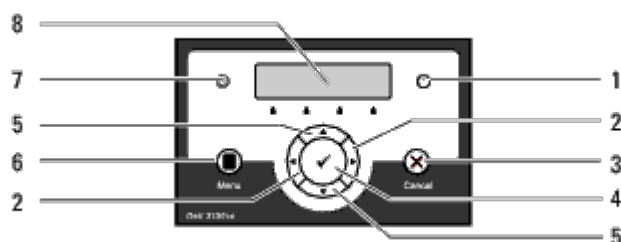

1. Error indicator
  - Lights orange when an error occurs and blinks when an unrecoverable print error occurs.
2. ◀ ▶ buttons
  - In the Menu mode, selects submenus or setting values.
3. **Cancel** button
  - Cancels the current print job.
  - In the topmenu of the Menu mode, switches to the Print mode.
  - In the submenu of the Menu mode, switches to the upper hierarchy of the menu.
4. ✓ (**Set**) button
  - In the Menu mode, displays the selected menu or item and determines the selected value.
5. ▼ ▲ buttons
  - In the Menu mode, scrolls through menus or items. To enter numbers or passwords for secure print jobs, press these buttons.
6. **Menu** button
  - In the Print mode, switches to the Menu mode.
  - In the Menu mode, switches to the Print mode.
7. Ready indicator
  - Lights green when the printer is ready or sleeping and blinks when data is being received.
8. LCD Panel

---

## Printing a Panel Settings Page

The panel settings page shows current settings for the operator panel menus.

## When Using the Operator Panel

1. Press **Menu** button.
2. Press ▼ button until **Report/List** appears, and then press ✓ (**Set**) button.
3. Press ▼ button until **Panel Settings** appears, and then press ✓ (**Set**) button.

The panel settings page is printed.

## When Using the Tool Box

1. Click **start® All Programs® Dell Printers® Dell 3130cn Color Laser Printer® Tool Box**.

The **Select Printer** dialog box opens.

2. Click **Dell 3130cn Color Laser PCL 6** listed in **Printer Name**, and then click **OK**.

The **Tool Box** opens.

3. Click the **Printer Settings Report** tab.
4. Select **Reports** from the list at the left side of the page.

The **Reports** page is displayed.

5. Click the **Panel Settings** button.

The panel settings page is printed.

---

[Back to Contents Page](#)

# Printer Settings

- [Printing a Printer Settings Page](#)
- [Using the Operator Panel to Change Printer Settings](#)
- [Using the Tool Box to Change the Printer Settings](#)
- [Using the Dell Printer Configuration Web Tool to Change Printer Settings](#)
- [Resetting Defaults](#)

You can change most printer settings from your software programs. If your printer is attached to the network, you can change settings from the **Dell Printer Configuration Web Tool**. To launch the **Dell Printer Configuration Web Tool**, type the printer's IP address in your Web browser. To find your printer's IP address, see "[Printing a Printer Settings Page](#)".

Settings from the software program update the default printer settings for the printer. Settings from the printer driver only apply to the job you are sending to the printer.

If you cannot change a setting from your software program, use the operator panel, Tool Box or the **Dell Printer Configuration Web Tool**. Changing a printer setting from the operator panel, Tool Box or from the **Dell Printer Configuration Web Tool** makes that setting the user default.

---

## Printing a Printer Settings Page

You can verify the detailed printer settings by printing a printer settings page.

### When Using the Operator Panel

1. Press **Menu** button.
2. Press ▼ button until **Report/List** appears, and then press ✓ (**Set**) button.
3. **Printer Setting** is displayed. Press ✓ (**Set**) button.

The printer settings page is printed.

### When Using the Tool Box

1. Click **start® All Programs® Dell Printers® Dell 3130cn Color Laser Printer® Tool Box**.

The **Select Printer** dialog box opens.

2. Click **Dell 3130cn Color Laser PCL 6** listed in **Printer Name**, and then click **OK**.

The **Tool Box** opens.

3. Click the **Printer Settings Report** tab.
4. Select **Reports** from the list at the left side of the page.

The **Reports** page is displayed.

5. Click the **Printer Settings** button.

The printer settings page is printed.

---

# Using the Operator Panel to Change Printer Settings

You can select menu items and corresponding values from the operator panel.

When you first enter the menus from the operator panel, you see an asterisk (\*) next to a value in the menus.

Factory defaults may vary for different countries.

This asterisk indicates the factory default menu setting. These settings are the original printer settings.

When you select a new setting from the operator panel, an asterisk appears next to the setting to identify it as the current user default menu setting.

These settings are active until new ones are selected or the factory defaults are restored.

To select a new value as a setting:

1. Press **Menu** button.
2. Press ▼ or ▲ button until the desired menu appears, and then press ✓ **(Set)** button.
3. Press ▼ or ▲ button until the desired menu or menu item appears, and then press ✓ **(Set)** button.
  - If the selection is a menu, the menu is opened and the first printer setting in the menu appears.
  - If the selection is a menu item, the default menu setting for the menu item appears. (The current user default menu setting has an asterisk (\*) beside it.)

Each menu item has a list of values for the menu item. A value can be:

- A phrase or word to describe a setting
  - A numerical value that can be changed
  - An On or Off setting
  - Press ▲ and ▼ buttons at the same time. This will restore the factory default menu settings. Press ✓ **(Set)** button to return the settings to the factory default menu settings.
4. Press ▼ or ▲ button to scroll until the desired value appears.
  5. Press ✓ **(Set)** button.

This enables the setting value, which is indicated by an asterisk (\*) next to the setting value.

6. Press **Cancel** or ◀ button to return to the previous menu.

To continue setting other items, select the desired menu. To quit setting new values, press **Cancel** button.

Driver settings may override changes previously made and may require you to change the operator panel defaults.

---

# Using the Tool Box to Change the Printer Settings

You can select menu items and corresponding values from the Tool Box.

Factory defaults may vary for different countries.

These settings are active until new ones are selected or the factory defaults are restored.

To select a new value as a setting:

1. Click **start® All Programs® Dell Printers® Dell 3130cn Color Laser Printer® Tool Box**.

The **Select Printer** dialog box opens.

2. Click **Dell 3130cn Color Laser PCL 6** listed in **Printer Name**, and then click **OK**.

The **Tool Box** opens.

3. Click the **Printer Maintenance** tab.
4. Select the desired menu item.

Each menu item has a list of values for the menu item. A value can be:

- A phrase or word to describe a setting
- A numerical value that can be changed
- An On or Off setting

5. Select the desired value, and then click the associated button with each menu item.

Driver settings may override changes previously made and may require you to change the Tool Box defaults.

---

## Using the Dell Printer Configuration Web Tool to Change Printer Settings

If your printer is connected to the network, you can change the device settings from your Web browser. If you are a network administrator, you can clone the printer settings of one printer to one or all printers on the network.

Type your printer's IP address in your Web browser. Choose **Printer Settings** from the topics list, and then select the **Printer Settings** you want to change.

To copy your printer settings to another printer on the network, choose **Copy Printer Settings** from the topics list, and then type the other printer's IP address.

If you do not know your printer's IP address, see the printer settings page. To print a printer settings page:

## When Using the Operator Panel

1. Press **Menu** button.
2. Press ▼ button until **Report/List** appears, and then press ✓ (**Set**) button.
3. **Printer Setting** is displayed. Press ✓ (**Set**) button.

The printer settings page is printed.

## When Using the Tool Box

1. Click **start® All Programs® Dell Printers® Dell 3130cn Color Laser Printer® Tool Box**.

The **Select Printer** dialog box opens.

2. Click **Dell 3130cn Color Laser PCL 6** listed in **Printer Name**, and then click **OK**.

The **Tool Box** opens.

3. Click the **Printer Settings Report** tab.
4. Select **Reports** from the list at the left side of the page.

The **Reports** page is displayed.

5. Click the **Printer Settings** button.

The printer settings page is printed.

---

## Resetting Defaults

After executing this function and rebooting the printer, all the menu parameters, except the parameters for the network, are reset to their default values.

### When Using the Operator Panel

1. Press **Menu** button.
2. Press ▼ button until **Admin Menu** appears, and then press ✓ **(Set)** button.
3. Press ▼ button until **Maintenance** appears, and then press ✓ **(Set)** button.
4. Press ▼ button until **Reset Defaults** appears, and then press ✓ **(Set)** button.
5. The **Are you sure?** message appears on the operator panel. Press ✓ **(Set)** button.
6. Turn off the printer, and then on again to apply the settings.

### When Using the Tool Box

1. Click **start® All Programs® Dell Printers® Dell 3130cn Color Laser Printer® Tool Box**.

The **Select Printer** dialog box opens.

2. Click **Dell 3130cn Color Laser PCL 6** listed in **Printer Name**, and then click **OK**.

The **Tool Box** opens.

3. Click the **Printer Maintenance** tab.
4. Select **Reset Defaults** from the list at the left side of the page.

The **Reset Defaults** page is displayed.

5. Click **Start**.

The printer is turned off automatically to apply the settings.

## Initializing NVRAM for Network Settings

You can initialize the IP address and network-related settings by initializing NVRAM for Network settings.

1. Press **Menu** button.
2. Press ▼ button until **Admin Menu** appears, and then press ✓ **(Set)** button.
3. Press ▼ button until **Network** appears, and then press ✓ **(Set)** button.
4. Press ▼ button until **Reset Wireless** or **Reset LAN** appears, and then press ✓ **(Set)** button.



5. The Are you sure? message appears on the operator panel. Press ✓ **(Set)** button.
  6. Turn off the printer, and then on again to apply the settings.
- 

[Back to Contents Page](#)

# Understanding the Tool Box Menus

- [Printer Settings Report](#)
- [Printer Maintenance](#)
- [Diagnosis](#)

The Tool Box allows you to view or specify the printer settings. You can also diagnose the printer settings by using the Tool Box.

The Tool Box consists of the **Printer Settings Report**, **Printer Maintenance**, and **Diagnosis** tabs.

 **NOTE:** A **Password** dialog box appears the first time you try to change settings on **ToolBox** when **Panel Lock** is set on the printer. In this case, input the password you specified, and click **OK** to apply the settings.

## Printer Settings Report

The **Printer Settings Report** tab includes the **Printer Information**, **Menu Settings**, **Reports**, **Network Settings**, and **TCP/IP Settings** pages.

 **NOTE:** Values marked by an asterisk (\*) are the factory default menu settings.

## Printer Information

**Purpose:**

To display the printer's system information.

**Values:**

<b>Dell Service Tag Number</b>	Displays Dell's service tag number.
<b>Printer Serial Number</b>	Displays the printer's serial number.
<b>Printer Type</b>	Displays the type of printing for the printer. Color Laser is displayed normally.
<b>Asset Tag Number</b>	Displays the printer's asset tag number.
<b>Memory Capacity</b>	Displays the memory capacity.
<b>Processor Speed</b>	Displays the processing speed.
<b>Firmware Version</b>	Displays the version of the controller.
<b>Network Firmware Version</b>	Displays the NIC version.
<b>MCU Firmware Version</b>	Displays the version of the MCU firmware.
<b>Printing Speed (Color)</b>	Displays the speed for color printing.
<b>Printing Speed (Monochrome)</b>	Displays the speed for monochrome printing.

## Menu Settings

**Purpose:**

To display the printer's menu settings.

**Values:**

	Power Saver Timer Mode 1	Displays the amount of time before the printer enters the power saver timer mode 1 after it finishes a job.
	Power Saver	Displays the amount of time before the printer enters the power saver timer mode 2

**System Settings**

Timer Mode 2	after it finishes a job.	
Control Panel Tone	Displays whether to emit the tone when the operator panel input is correct. <b>Off</b> indicates that the tone is disabled.	
Invalid Key Tone	Displays whether to emit the tone when the operator panel input is incorrect. <b>Off</b> indicates that the tone is disabled.	
Machine Ready Tone	Displays whether to emit the tone when the printer becomes ready. <b>Off</b> indicates that the tone is disabled.	
Job Complete Tone	Displays whether to emit the tone when a job is complete. <b>Off</b> indicates that the tone is disabled.	
Fault Tone	Displays whether to emit the tone when a job ends abnormally. <b>Off</b> indicates that the tone is disabled.	
Alert Tone	Displays whether to emit the tone when a problem occurs. <b>Off</b> indicates that the tone is disabled.	
Out of Paper Alert Tone	Displays whether to emit the tone when the printer runs out of paper. <b>Off</b> indicates that the tone is disabled.	
Low Toner Alert Tone	Displays whether to emit the tone when the toner or some other consumable is low. <b>Off</b> indicates that the tone is disabled.	
Base Tone	Displays whether to emit the tone when the operator panel is returned to the default by scrolling the loop menu. <b>Off</b> indicates that the tone is disabled.	
Fault Time-Out	Displays the amount of time the printer cancels for a job stops abnormally.	
Time-Out	Displays the amount of time the printer waits for data to arrive from the computer.	
Panel Language	Displays the language to be used on the operator panel.	
Auto Log Print	Displays whether the printer outputs a log of completed jobs from the printer automatically.	
Print ID	Displays where to print a user ID on the output paper.	
Print Text	Displays whether the printer outputs PDL (Page Description Language) data, which is not supported by the printer, as text when the printer receives it	
Banner Sheet Insert Position	Displays where to insert a banner sheet.	
Banner Sheet Specify Tray	Displays which input tray to use to insert a banner sheet.	
RAM Disk	Displays whether to allocate RAM for the file system for the Secure Print and Proof Print features. This item is only available when the 256 MB, or higher, optional memory is installed, and also when the optional hard disk is not installed.	
Odd Page 2 Sided	Displays how the odd last page is printed when using duplex printing.	
Substitute Tray	Displays whether to use another size paper when the paper that is loaded in the specified tray does not match the paper size settings for the current job.	
mm/inch	Displays the measurement unit used on the operator panel.	
<b>Paper Density</b>	Plain	Displays the plain paper density settings.
	Label	Displays the label paper density settings.
<b>Auto Registration Adjustment</b>	Auto Registration Adjustment	Displays whether to automatically adjust color registration.
<b>Adjust Altitude</b>	Adjust Altitude	Displays the altitude of the location where the printer is installed.
<b>Non-Dell Toner</b>	Non-Dell Toner	Displays whether or not to use another manufacturer's toner cartridge.
	Tray 1 Paper Type	Displays the paper type setting of the tray 1.
	Tray 1 Paper Size	Displays the paper size setting of the tray 1.
	Tray 1 Custom	Displays the length of custom size paper loaded in the tray 1.

<b>Tray Settings</b>	Size - Y	
	Tray 1 Custom Size - X	Displays the width of custom size paper loaded in the tray 1.
	Tray 2 Paper Type*1	Displays the paper type setting of the tray 2.
	Tray 2 Paper Size*1	Displays the paper size setting of the tray 2.
	Tray 2 Custom Size - Y*1	Displays the length of custom size paper loaded in the tray 2.
	Tray 2 Custom Size - X*1	Displays the width of custom size paper loaded in the tray 2.
	MPF Mode	Displays the paper size and type when paper is loaded in the MPF.
	MPF Display Popup	Displays a popup menu that prompts to set the paper size and type when paper is loaded in the MPF.
	MPF Paper Type	Displays the paper type setting of the multipurpose feeder (MPF).
	MPF Paper Size	Displays the paper size setting of the MPF.
	MPF Custom Size - Y	Displays the length of custom size paper loaded in the MPF.
	MPF Custom Size - X	Displays the width of custom size paper loaded in the MPF.

\*1 This item is only available when the optional 550 sheet feeder is installed.

## Reports

### Purpose:

To print the printer's settings and history information.

The reports are printed in the paper size specified in printer settings. The default is A4 or Letter.

### Values:

<b>Printer Settings</b>	Click to print a detailed list of the printer settings.
<b>Panel Settings</b>	Click to print a detailed list of the panel settings.
<b>Job History</b>	Click to print the printer's Completed Jobs history.
<b>Error History</b>	Click to print the printer's error history.
<b>Print Meter</b>	Click to print the print meter.
<b>Color Test Page</b>	Click to print a color test page.

## TCP/IP Settings

### Purpose:

To display the current settings of TCP/IP (Transmission Control Protocol/Internet Protocol) protocol.

### Values:

<b>IP Address Mode</b>	Displays the method for acquiring the IP address.
<b>IP Address</b>	Displays the printer's IP address.
<b>Subnet Mask</b>	Displays the subnet mask.
<b>Gateway Address</b>	Displays the gateway address.

# Printer Maintenance

The **Printer Maintenance** tab includes the **System Settings, Paper Density, Registration Adjustment, Adjust Altitude, Reset Defaults, Non-Dell Toner, Initialize PrintMeter, Tray Setting, TCP/IP Settings, and Network Settings** pages.

 **NOTE:** Values marked by an asterisk (\*) are the factory default menu settings.

## System Settings

### Purpose:

To Use these settings to configure the printer's power management, warning tones, time-out time, operator panel language setting, job log auto print, position of the Print ID, setting of the dump print, setting of the additional memory, setting of the substitute sheet, mm/inch setting, and duplex print settings.

### Values:

<b>Power Saver Timer Mode 1 *1</b>	5-60 Min.	Specifies the time before the printer enters the power saver timer mode 1 (sleep mode) after it finishes a job.	
	5 Min.*		
<b>Power Saver Timer Mode 2 *1</b>	1-6 Min.	Specifies the time before the printer enters the power saver timer mode 2 (deep sleep mode) after it finishes a job.	
	6 Min.*		
<b>Audio Tones</b>	<b>Control Panel Tone</b>	Off*	Does not emit a tone when the operator panel input is correct.
		On	Emits a tone when the operator panel input is correct.
	<b>Invalid Key Tone</b>	Off*	Does not emit a tone when the operator panel input is incorrect.
		On	Emits a tone when the operator panel input is incorrect.
	<b>Machine Ready Tone</b>	Off*	Does not emit a tone when the printer becomes ready.
		On	Emits a tone when the printer becomes ready.
	<b>Job Complete Tone</b>	Off*	Does not emit a tone when a job is complete.
		On	Emits a tone when a job is complete.
	<b>Fault Tone</b>	Off*	Does not emit a tone when a job ends abnormally.
		On	Emits a tone when a job ends abnormally.
	<b>Alert Tone</b>	Off*	Does not emit a tone when a problem occurs.
		On	Emits a tone when a problem occurs.
	<b>Out of Paper Alert Tone</b>	Off*	Does not emit a tone when the printer runs out of paper.
		On	Emits a tone when the printer runs out of paper.
	<b>Low Toner Alert Tone</b>	Off*	Does not emit a tone when toner or some other consumable is low.
		On	Emits a tone when toner or some other consumable is low.
	<b>Base Tone</b>	Off*	Does not emit a tone when the operator panel display is returned to the default settings by scrolling the loop menu.
		On	Emits a tone when the operator panel display is returned to the default settings by scrolling the loop menu.
<b>Fault Time-Out</b>	0	Disables the fault time-out.	
	3-300 sec	Specifies the amount of time the printer cancels for a job stops abnormally.	
	60 sec*		
<b>Time-Out</b>	0	Disables the job time-out.	
	5-300 sec	Specifies the amount of time before the printer cancels for jobs that stop abnormally.	
	30 sec*		
	English*		

<b>Panel Language</b>	French	Specifies the language to be used on the operator panel.
	Italian	
	German	
	Spanish	
	Dutch	
	Danish	
	Norwegian	
	Swedish	
<b>Auto Log Print</b>	Off*	Does not automatically output a log of completed jobs from the printer.
	On	Outputs a log of completed jobs from the printer automatically.
<b>Print ID</b>	Off*	Does not print the user ID.
	Top Left	Prints the user ID on the specified location.
	Top Right	
	Bottom Left	
	Bottom Right	
<b>Print Text</b>	Off	Does not print the received PDL data as text data.
	On*	Prints the received PDL data as text data.
<b>Banner Sheet Insert Position</b>	Off*	Does not insert the banner sheet.
	Front	Inserts the banner sheet to the specified position.
	Back	
	Front & Back	
<b>Banner Sheet Specify Tray</b>	Tray 1*	Specifies the input tray to insert the banner sheet.
	Tray 2* <sup>2</sup>	
	MPF	
<b>RAM Disk *3</b>	Disable	Does not allocate RAM for the disk file system. Secure Print, and Proof Print jobs will abort and be recorded to the job log.
	50-500MB* <sup>4</sup>	Allocates RAM for the disk file system automatically.
	50-1000MB* <sup>5</sup>	
<b>Odd Page 2 Sided</b>	1 Sided*	Prints the odd last page upside down to the paper
	2 Sided	Prints the odd last page in normal direction to the paper
<b>Substitute Tray</b>	Off*	No tray size substitute accepted.
	Larger Size	Substitutes paper of next largest size. When there is no larger paper size, the printer substitutes paper of nearest size.
	Nearest Size	Substitutes paper of nearest size.
	MPF Feed	Substitutes paper in the MPF.
<b>mm/inch</b>	millimeter (mm)*	Selects millimeter or inch as the default measurement unit.
	inch (")* <sup>6</sup>	
<b>Apply New Settings</b>		After you complete the settings, press the <b>Apply New Settings</b> button to apply the changes.
<b>Restart printer to apply new settings</b>		Press the <b>Restart printer to apply new settings</b> button to apply the changes.

\*1 Enter 5 to put the printer in the power saver timer mode five minutes after it finishes a job. This uses much less energy, but requires more warm-up time for the printer. Enter 5if your printer shares an electrical circuit with room lighting and you notice lights flickering.

Select a high value if your printer is in constant use. Under most circumstances, this keeps the printer ready to operate

with minimum warm-up time. Select a value between 5 and 60 minutes for the power saver timer mode if you want a balance between energy consumption and a shorter warm-up period.

The printer automatically returns to the standby mode from the power saver timer mode when it receives data from the computer. You can also return the printer to the standby mode by pressing any button on the operator panel.

\*2 This item is only available when the optional 550 sheet feeder is installed.

\*3 This item is only available when the 512 MB, or higher, optional memory is installed, and also when the optional hard disk is not installed.

\*4 Only displayed when the optional 512 MB memory is installed.

\*5 Only displayed when the optional 1024 MB memory is installed.

\*6 The factory default setting of **mm/inch** is set to **inch(")** in the United States.

## Paper Density

### Purpose:

To specify the paper density settings.

### Values:

Plain	Normal*	Specifies plain paper density settings.
	Light	
Label	Normal*	Specifies label paper density settings.
	Light	
Apply New Settings		After you complete the settings, press the <b>Apply New Settings</b> button to apply the changes.
Restart printer to apply new settings		Press the <b>Restart printer to apply new settings</b> button to apply the changes.

## Registration Adjustment

### Purpose:

To set Color Registration Adjustment (individual yellow, magenta, cyan correction) settings. When **Auto Registration Adjustment** is set to **On**, the printer prints the color registration chart and to adjust the color registration by using the chart. This function is required after the printer is set up or moved.

### Values:

Auto Registration Adjustment	Off	Does not perform color registration automatically.	
	On*	Performs color registration automatically.	
Auto Correct		Click <b>Start</b> to perform color registration automatically.	
Color Regi Chart		Click <b>Start</b> to print a color registration chart.	
Enter Number	Yellow	-	Specifies lateral (perpendicular to paper feed direction) color adjustment values that are found in the color registration chart individually for <b>Yellow</b> , <b>Magenta</b> , and <b>Cyan</b> .
		9-	
		+9	
	0*		
	Magenta	-	
		9-	
+9			
0*			
Cyan	-		
	9-		
	+9		

	0*	
<b>Apply New Settings</b>	After you complete the settings, press the <b>Apply New Settings</b> button to apply the changes.	
<b>Restart printer to apply new settings</b>	Press the <b>Restart printer to apply new settings</b> button to apply the changes.	

## Adjust Altitude

### Purpose:

To specify the altitude of the location where the printer is installed.

The discharge phenomenon for charging the photo conductor varies with barometric pressure. Adjustments are performed by specifying the altitude of the location where the printer is being used.

### Values:

0 meter*	Specifies the altitude of the location where the printer is installed.
1000 meters	
2000 meters	
3000 meters	
<b>Apply New Settings</b>	After you complete the settings, press the <b>Apply New Settings</b> button to apply the changes.
<b>Restart printer to apply new settings</b>	Press the <b>Restart printer to apply new settings</b> button to apply the changes.

## Reset Defaults

### Purpose:

To initialize the NV (nonvolatile) memory for system parameters. After executing this function to automatically restart the printer, the menu parameters, or data are reset to their default values.

### Values:

<b>Start</b>	Initializes system parameters.
--------------	--------------------------------

## Non-Dell Toner

When Non-Dell print cartridge is used, the printer may be severely damaged and may not be covered by your warranty.

### Purpose:

To specify whether or not to use another manufacturer's print cartridge.

### Values:

<b>Non-Dell Toner</b>	Off*	Disables the use of another manufacturer's print cartridge.
	On	Enables the use of another manufacturer's print cartridge.
<b>Apply New Settings</b>	After you complete the settings, press the <b>Apply New Settings</b> button to apply the changes.	
<b>Restart printer to apply new settings</b>	Press the <b>Restart printer to apply new settings</b> button to apply the changes.	

## Initialize PrintMeter



**Purpose:**

To initialize the printer's PrintMeter. Executing this function restarts the printer, and the value of the meter resets to 0.

**Values:**

<b>Initialize PrintMeter</b>	Click <b>Start</b> to initialize the PrintMeter.
------------------------------	--------------------------------------------------

## Tray Settings

**Purpose:**

To specify the paper types and sizes for input trays respectively.

**Values:**

<b>Tray 1 Paper Type</b>	Plain*	Specifies the type of paper loaded in the tray 1.
	Plain Thick	
	Covers	
	Covers Thick	
	Label	
	Coated	
	Coated Thick	
	Recycled	
	JPN Coated	
	Letterhead	
	Preprinted	
	Prepunched	
	Color	
<b>Tray 1 Paper Size</b>	Auto*	Specifies the size of paper loaded in the tray 1.
	Custom Size	
<b>Tray 1 Custom Size - Y</b>	Specifies the length of custom size paper loaded in the tray 1. The available range is from 210 mm (8.3 in.) to 355 mm (14.0 in.).	
<b>Tray 1 Custom Size - X</b>	Specifies the width of custom size paper loaded in the tray 1. The available range is from 148 mm (5.8 in.) to 215 mm (8.5 in.).	
<b>Tray 2 Paper Type*<sup>1</sup></b>	Plain*	Specifies the type of paper loaded in the tray 2.
	Plain Thick	
	Covers	
	Covers Thick	
	Label	
	Coated	
	Coated Thick	
	Recycled	
	JPN Coated	
	Letterhead	
	Preprinted	
	Prepunched	
	Color	
<b>Tray 2 Paper Size*<sup>1</sup></b>	Auto*	Specifies the size of paper loaded in the tray 2.

	Custom Size	
<b>Tray 2 Custom Size - y*<sup>1</sup></b>	Specifies the length of custom size paper loaded in the tray 2. The available range is from 210 mm (8.3 in.) to 355 mm (14.0 in.).	
<b>Tray 2 Custom Size - x*<sup>1</sup></b>	Specifies the width of custom size paper loaded in the tray 2. The available range is from 148 mm (5.8 in.) to 215 mm (8.5 in.).	
<b>MPF Mode</b>	Panel Specified	Specifies the way of specification for size of paper loaded in the MPF.
	Driver Specified*	
<b>Display Popup</b>	Off	Does not display a popup message that prompts to set <b>MPF Paper Type</b> and <b>MPF Paper Size</b> when paper is loaded in the MPF.
	On*	Displays a popup message that prompts to set <b>MPF Paper Type</b> and <b>MPF Paper Size</b> when paper is loaded in the MPF.
<b>MPF Paper Type</b>	Plain*	Specifies the type of paper loaded in the MPF.
	Plain Thick	
	Transparency	
	Covers	
	Covers Thick	
	Label	
	Coated	
	Coated Thick	
	Envelope	
	Recycled	
	JPN Coated	
	Postcard JPN	
	Letterhead	
	Preprinted	
	Prepunched	
	Color	
	Plain S2	
	Plain Thick S2	
	Covers S2	
	Covers Thick S2	
Coated S2		
Coated Thick S2		
Recycled S2		
JPN Coated S2		
Postcard JPN S2		
Color S2		
	A4 (210 x 297 mm)	
	A5 (148 x 210 mm)	
	B5 (182 x 257 mm)	
	Driver Size*	
	Letter (8.5 x 11")	

<b>MPF Paper Size</b>	Folio (8.5 x 13")	Specifies the size of paper loaded in the MPF.
	Legal (8.5 x 14")	
	Executive (7.25 x 10.5")	
	Monarch (3.875 x 7.5")	
	DL (110 x 220 mm)	
	C5 (162 x 229 mm)	
	Envelope #10 (4.125 x 9.5")	
	Postcard JPN	
	Youkei 2 (114 x 162 mm)	
	Youkei 3 (98 x 148 mm)	
	Youkei 4 (105 x 235 mm)	
	Youchoukei 3 (120 x 235 mm)	
	Choukei 3 (120 x 235 mm)	
Custom Size		
<b>MPF Custom Size - Y</b>	Specifies the length of custom size paper loaded in the MPF. The available range is from 127 mm (5.0 in.) to 355 mm (14.0 in.).	
<b>MPF Custom Size - X</b>	Specifies the width of custom size paper loaded in the MPF. The available range is from 77 mm (3.0 in.) to 220 mm (8.7 in.).	
<b>Apply New Settings</b>	After you complete the settings, press the <b>Apply New Settings</b> button to apply the changes.	
<b>Restart printer to apply new settings</b>	Press the <b>Restart printer to apply new settings</b> button to apply the changes.	
*1 This item is only available when the optional 550 sheet feeder is installed.		

## TCP/IP Settings

### Purpose:

To configure TCP/IP settings.

### Values:

<b>IP Address Mode</b>	AutoIP*	Automatically sets the IP address. A random value in the range of 169.254.1.0 to 169.254.254.255 that is not currently in use on the network is set as the IP address. The subnet mask is set as 255.255.0.0.
	DHCP	Sets the IP address using DHCP.
	BOOTP	Sets the IP address using BOOTP.
	RARP	Sets the IP address using RARP.
	Manually Set	Manually sets the IP address.
<b>IP Address</b>	Manually sets the IP address allocated to the printer. It is allocated to the printer using the format nnn.nnn.nnn.nnn. Each octet that makes up nnn.nnn.nnn.nnn is a value in the range of 0 to 254. 127 and any value in the range of 224 to 254 cannot be specified for the first octet of a gateway address.	

<b>Subnet Mask</b>	Manually sets the subnet mask. It is specified using the format nnn.nnn.nnn.nnn. Each octet that makes up nnn.nnn.nnn.nnn is a value in the range of 0 to 255. (255.255.255.255 cannot be specified as the subnet mask.)
<b>Gateway Address</b>	Manually sets the gateway address. It is specified using the format nnn.nnn.nnn.nnn. Each octet that makes up nnn.nnn.nnn.nnn is a value in the range of 0 to 254. 127 and any value in the range of 224 to 254 cannot be specified for the first octet of a gateway address.
<b>Apply New Settings</b>	After you complete the settings, press the <b>Apply New Settings</b> button to apply the changes.
<b>Restart printer to apply new settings</b>	Press the <b>Restart printer to apply new settings</b> button to apply the changes.

## Network Settings

### Purpose:

To display the server settings of the **Dell Printer Configuration Web Tool**.

 **NOTE:** When the printer is connected to the local port, this setting cannot be displayed.

### Values:

<b>Display</b>	Displays the server settings of the Dell Printer Configuration Web Tool.	
<b>Display of EWS</b>	Off	Disable to display the server settings of the Dell Printer Configuration Web Tool.
	On*	Enable to display the server settings of the Dell Printer Configuration Web Tool.

## Diagnosis

The **Diagnosis** tab includes the **Chart Print** and **Environment Sensor Info** pages.

 **NOTE:** Values marked by an asterisk (\*) are the factory default menu settings.

## Chart Print

### Purpose:

To various charts that can be used for the printer's diagnosis.

### Values:

<b>Pitch Configuration Chart</b>	Outputs full halftone pages for yellow, magenta, cyan, and black. Also outputs pages to check the pitch. A total of five pages are output. The chart is output to A4 or Letter size paper.
<b>Ghost Configuration Chart</b>	Outputs a chart to check for ghost printing. One page is output. The chart is output to A4 or Letter size paper.
<b>4 Colors Configuration Chart</b>	Bands of yellow, magenta, cyan, and black are output with varying density. One page is output. The chart is output to A4 or Letter size paper.
<b>MQ Chart</b>	Outputs charts to check for the binding in A4 or Letter.
<b>Alignment Chart</b>	Outputs a chart to check for proper alignment of the print image on the paper. One page is output. The chart is output to A4 or Letter size paper.
<b>PHD Refresh Configuration</b>	Outputs a chart to check the light fatigue of the drums of the print cartridges. One page is output. The chart is output to A4 or Letter size paper.

## Environment Sensor Info

**Purpose:**

To output the printer's internal environment sensor information to **Result** by pressing the **Get Environment Sensor Info** button.

---

[Back to Contents Page](#)

# Understanding the Printer Menus

- [Report/List](#)
- [Admin Menu](#)
- [Tray Settings](#)
- [Stored Print](#)
- [Setting Panel Lock](#)

When your printer is configured as a network printer available to a number of users, the access to the `Admin Menu` menus can be limited. This prevents other users from using the operator panel to inadvertently change a printer user default that has been set by the administrator. In this case, you can access the `Stored Document`, and `Tray Settings` menus only.

However, you can use your printer driver to override printer user defaults and select settings for individual print jobs.

To complete print jobs, you may also need to modify tray settings.

---

## Report/List

Use the `Report/List` menu to print various types of reports and lists.

## Printer Setting

### **Purpose:**

To print a list of the current user default values, the installed options, the amount of installed print memory, and the status of printer supplies.

## Panel Settings

### **Purpose:**

To print a detailed list of all the settings on the operator panel menus.

## PCL Fonts List

### **Purpose:**

To print a sample of the available PCL fonts.

### **See also:**

["Understanding Fonts"](#), ["Printing a Font Sample List"](#)

## PCL Macro List

### **Purpose:**

To print the information on the downloaded PCL macro.

## PS Fonts List

### **Purpose:**

To print a sample of the available PostScript fonts.

See also:

["Understanding Fonts"](#), ["Printing a Font Sample List"](#)

## Job History

**Purpose:**

To print a detailed list of the print jobs that have been processed. This list contains the last 20 jobs.

## Error History

**Purpose:**

To print a detailed list of paper jams and fatal errors.

## Print Meter

**Purpose:**

To print the reports for the total number of pages printed. When printed using either the printer control panel or **Dell Printer Configuration Web Tool**, the report will be titled **Print Volume Report**.

## Color Test Page

**Purpose:**

To print a page for testing colors.

## Stored Document

**Purpose:**

To print a list of all files that are stored for `Secure Print` and `Proof Print` in the RAM disk.

 **NOTE:** The `Stored Document` is displayed only when the optional hard disk, 512 MB or more memory is installed on the printer and `RAM Disk` under `System Settings` is enabled.

---

## Admin Menu

Use the **Admin Menu** menu to configure a variety of printer features.

## Network

Use the `Network` menu to change the printer settings affecting jobs sent to the printer through the wired or wireless network.

 **NOTE:** Values marked by an asterisk (\*) are the factory default menu settings.

### Ethernet

**Purpose:**

To specify the communication speed and the duplex settings of Ethernet. The change becomes effective after the printer is turned off and then on again.

**Values:**

<b>Auto*</b>	Detects the Ethernet settings automatically.
<b>10Base Half</b>	Uses 10base-T half-duplex.
<b>10Base Full</b>	Uses 10base-T full-duplex.
<b>100Base Half</b>	Uses 100base-TX half-duplex.
<b>100Base Full</b>	Uses 100base-TX full-duplex.

**Status****Purpose:**

To display the information on the wireless signal strength. Any change cannot be made on the operator panel to improve the status of the wireless connection.

**Values:**

<b>Good</b>	Indicates good signal strength.
<b>Acceptable</b>	Indicates marginal signal strength.
<b>Low</b>	Indicates insufficient signal strength.
<b>No Reception</b>	Indicates that no signal is received.

 **NOTE:** This item is only displayed when an optional wireless printer adapter is installed.

**Reset Wireless****Purpose:**

To initialize wireless network settings. After executing this function and rebooting the printer, all wireless network settings are reset to their default values.

 **NOTE:** This item is only displayed when an optional wireless printer adapter is installed.

**TCP/IP****Purpose:**

To configure TCP/IP settings. The change becomes effective after the printer is turned off and then on again.

**Values:**

<b>IP Mode</b>	<b>Dual Stack*</b>		Uses both IPv4 and IPv6 to set the IP address.
	<b>IPv4 Mode</b>		Uses IPv4 to set the IP address.
	<b>IPv6 Mode</b>		Uses IPv6 to set the IP address.
<b>IPv4</b>	<b>Get IP Address</b>	<b>AutoIP*</b>	Automatically sets the IP address.
		<b>BOOTP</b>	Uses BOOTP to set the IP address.
		<b>RARP</b>	Uses RARP to set the IP address.
		<b>DHCP</b>	Uses DHCP to set the IP address.
		<b>Panel</b>	Enables the IP address entered on the operator panel.
	<b>IP Address</b>		Sets the IP address allocated to the printer by using the keys on the operator panel.
<b>Subnet Mask</b>		Sets the subnet mask.	



	<b>Gateway Address</b>	Sets the gateway address.
<b>IPsec</b> <sup>*1</sup>		Disables IPsec.
*1 Only displayed when an optional network protocol adapter is installed and IPsec is enabled.		

## Protocol

### Purpose:

To enable or disable each protocol. The change becomes effective after the printer is turned off and then on again.

### Values:

<b>LPD</b>	<b>Enable*</b>	Enables the LPD port.	
	<b>Disable</b>	Disables the LPD port.	
<b>Port9100</b>	<b>Enable*</b>	Enables the Port9100 port.	
	<b>Disable</b>	Disables the Port9100 port.	
<b>IPP</b> <sup>*1</sup>	<b>Enable*</b>	Enables the IPP port.	
	<b>Disable</b>	Disables the IPP port.	
<b>SMB TCP/IP</b> <sup>*1</sup>	<b>Enable*</b>	Uses TCP/IP for SMB.	
	<b>Disable</b>	Does not use TCP/IP for SMB.	
<b>SMB NetBEUI</b> <sup>*1</sup>	<b>Enable*</b>	Uses NetBEUI for SMB.	
	<b>Disable</b>	Does not use Net BEUI for SMB.	
<b>NetWare</b> <sup>*1</sup>	<b>NetWare IP</b>	<b>Enable*</b>	Uses IP for NetWare.
		<b>Disable</b>	Does not use IP for NetWare.
	<b>NetWare IPX</b>	<b>Enable*</b>	Uses IPX for NetWare.
		<b>Disable</b>	Does not use IPX for NetWare.
<b>WSD</b>	<b>Enable*</b>	Enables the WSD port.	
	<b>Disable</b>	Disables the WSD port.	
<b>SNMP</b>	<b>SNMP UDP</b>	<b>Enable*</b>	Enables the UDP.
		<b>Disable</b>	Disables the UDP.
	<b>SNMP IPX</b> <sup>*1</sup>	<b>Enable*</b>	Enables the IPX.
		<b>Disable</b>	Disables the IPX.
<b>E-Mail Alert</b>	<b>Enable*</b>	Enables the Email Alerts feature.	
	<b>Disable</b>	Disables the Email Alerts feature.	
<b>EWS</b>	<b>Enable*</b>	Enables an access to <b>Dell Printer Configuration Web Tool</b> embedded in the printer.	
	<b>Disable</b>	Disables an access to <b>Dell Printer Configuration Web Tool</b> embedded in the printer.	
<b>AppleTalk</b> <sup>*1</sup>	<b>Enable*</b>	Enables the AppleTalk.	
	<b>Disable</b>	Disables the AppleTalk.	
<b>Bonjour(mDNS)</b> <sup>*1</sup>	<b>Enable*</b>	Enables the Bonjour(mDNS).	
	<b>Disable</b>	Disables the Bonjour(mDNS).	
<b>Telnet</b>	<b>Enable*</b>	Enables the Telnet.	
	<b>Disable</b>	Disables the Telnet.	
<b>HTTP-SSL/TLS</b>	<b>Enable</b>	Enables the HTTP-SSL/TLS.	
	<b>Disable*</b>	Disables the HTTP-SSL/TLS.	

\* Only displayed when an optional network protocol adapter is installed.

## IPX/SPX

### Purpose:

To configure the IPX/SPX settings. The change becomes effective after the printer is turned off and then on again.

### Values:

<b>Auto*</b>	Automatically sets the frame type.
<b>Ethernet II</b>	Uses the Ethernet II frame type.
<b>Ethernet 802.3</b>	Uses the IEEE802.3 frame type.
<b>Ethernet 802.2</b>	Uses the IEEE802.2 frame type.
<b>Ethernet SNAP</b>	Uses the SNAP frame type.

 **NOTE:** This item is only displayed when an optional network protocol adapter is installed.

## IP Filter

### Purpose:

To block data received from certain IP addresses through the wired or wireless network. You can set up to five IP addresses. The change becomes effective after the printer is turned off and then on again.

### Values:

<b>No. n/Address (n is 1-5.)*<sup>1</sup></b>	Sets the IP address for Filter <i>n</i> .	
<b>No. n/Mask (n is 1-5.)*<sup>1</sup></b>	Sets the address mask for Filter <i>n</i> .	
<b>No. n/Mode (n is 1-5.)*<sup>1</sup></b>	<b>Off*</b>	Disable the IP Filter feature for Filter <i>n</i> .
	<b>Accept</b>	Accepts an access from the specified IP address.
	<b>Reject</b>	Rejects an access from the specified IP address.
* <sup>1</sup> This item is only available for LPD or Port9100.		

## IEEE 802.1x

### Purpose:

To disable the IEEE 802.1x authentication. The change becomes effective after the printer is turned off and then on again.

 **NOTE:** This item is only displayed when the IEEE 802.1x authentication is enabled and the optional network protocol adapter is installed, and also when the optional wireless printer adapter is not installed.

## Reset LAN

### Purpose:

To initialize wired network data stored in NV (non-volatile) memory. After executing this function and rebooting the printer, all wired network settings are reset to their default values.

## Adobe Protocol

### Purpose:

To specify PostScript communication protocol for each interface. You can configure the `Adobe Protocol` settings for the wired network. The change becomes effective after the printer is turned off and then on again.

**Values:**

<b>Auto*</b>	Used when auto-detecting the PostScript communication protocol.
<b>Standard</b>	Used when the communication protocol is in ASCII interface.
<b>BCP</b>	Used when the communication protocol is in binary format.
<b>TBCP</b>	Used when the communication protocol supports both ASCII and binary data to switch between them according to the specified control code.
<b>Binary</b>	Used when no special processing is required for data.

## Parallel

The `Parallel` menu can be adjusted to configure the parallel interface.

 **NOTE:** Values marked by an asterisk (\*) are the factory default menu settings.

## Port Status

**Purpose:**

To enable or disable the parallel interface. The change becomes effective after the printer is turned off and then on again.

**Values:**

<b>Enable*</b>	The parallel interface is enabled.
<b>Disable</b>	The parallel interface is disabled.

## ECP

**Purpose:**

To specify the ECP communication mode of the parallel interface. The change becomes effective after the printer is turned off and then on again.

**Values:**

<b>Enable*</b>	The ECP communication mode is enabled.
<b>Disable</b>	The ECP communication mode is disabled.

## Adobe Protocol

**Purpose:**

To specify PostScript communication protocol for parallel interface. You can configure the `Adobe Protocol` settings for the wired network. The change becomes effective after the printer is turned off and then on again.

**Values:**

<b>Auto</b>	Used when auto-detecting the PostScript communication protocol.
<b>Standard</b>	Used when the communication protocol is in ASCII interface.
<b>BCP</b>	Used when the communication protocol is in binary format.
<b>TBCP*</b>	Used when the communication protocol supports both ASCII and binary data to switch between them according to the specified control code.
<b>Binary</b>	Used when no special processing is required for data.

## USB Settings

Use the `USB Settings` menu to change printer settings affecting a USB port.

 **NOTE:** Values marked by an asterisk (\*) are the factory default menu settings.

### Port Status

#### Purpose:

To enable or disable the USB interface. The change becomes effective after the printer is turned off and then on again.

#### Values:

<b>Enable*</b>	The USB interface is enabled.
<b>Disable</b>	The USB interface is disabled.

### Adobe Protocol

#### Purpose:

To specify PostScript communication protocol for USB interface. You can configure the `Adobe Protocol` settings for the wired network. The change becomes effective after the printer is turned off and then on again.

#### Values:

<b>Auto</b>	Used when auto-detecting the PostScript communication protocol.
<b>Standard</b>	Used when the communication protocol is in ASCII interface.
<b>BCP</b>	Used when the communication protocol is in binary format.
<b>TBCP*</b>	Used when the communication protocol supports both ASCII and binary data to switch between them according to the specified control code.
<b>Binary</b>	Used when no special processing is required for data.

## System Settings

Use the `System Settings` menu to configure a variety of printer features.

 **NOTE:** Values marked by an asterisk (\*) are the factory default menu settings.

### PowerSaver Time

#### Purpose:

To specify the time for transition to power saver mode.

#### Values:

<b>Mode1</b>	<b>5min.*</b>	Specifies the time for transition to Power Saver Mode 1 and Power Saver Mode 2 in minutes.
	<b>5-60min.</b>	
<b>Mode2</b>	<b>6min.*</b>	
	<b>1-6min.</b>	

Enter 5 to put the printer in power saver mode five minutes after it finishes a job. This uses much less energy, but requires more warm-up time for the printer. Enter 5 if your printer shares an electrical circuit with room lighting and you notice lights flickering.

Select a high value if your printer is in constant use. Under most circumstances, this keeps the printer ready to operate with minimum warm-up time. Select a value between 5 and 60 minutes for power save mode if you want a balance between energy consumption and a shorter warm-up period.

The printer automatically returns to the standby mode from the power saver mode when it receives data from the computer or remote fax printer. You can also return the printer to the standby mode by pressing any button on the operator panel.

## Audio Tones

### Purpose:

To configure settings for tones emitted by the printer during operation or when a warning message appears.

### Values:

<b>Control Panel</b>	<b>Off*</b>	Does not emit a tone when the operator panel input is correct.
	<b>On</b>	Emits a tone when the operator panel input is correct.
<b>Invalid Key</b>	<b>Off*</b>	Does not emit a tone when the operator panel input is incorrect.
	<b>On</b>	Emits a tone when the operator panel input is incorrect.
<b>Machine Ready</b>	<b>Off*</b>	Does not emit a tone when the printer becomes ready.
	<b>On</b>	Emits a tone when the printer becomes ready.
<b>Job Completed</b>	<b>Off*</b>	Does not emit a tone when a job is complete.
	<b>On</b>	Emits a tone when a job is complete.
<b>Fault Tone</b>	<b>Off*</b>	Does not emit a tone when a job ends abnormally.
	<b>On</b>	Emits a tone when a job ends abnormally.
<b>Alert Tone</b>	<b>Off*</b>	Does not emit a tone when a problem occurs.
	<b>On</b>	Emits a tone when a problem occurs.
<b>Out of Paper</b>	<b>Off*</b>	Does not emit a tone when the printer runs out of paper.
	<b>On</b>	Emits a tone when the printer runs out of paper.
<b>Low Toner Alert</b>	<b>Off*</b>	Does not emit a tone when toner or some other consumable is low.
	<b>On</b>	Emits a tone when toner or some other consumable is low.
<b>Base Tone</b>	<b>Off*</b>	Does not emit a tone when the operator panel display is returned to the default settings by scrolling the loop menu.
	<b>On</b>	Emits a tone when the operator panel display is returned to the default settings by scrolling the loop menu.

## Fault Time-Out

### Purpose:

Specifies in seconds the amount of time the printer should cancel for a job stops abnormally. The print job is cancelled if the time-out time is exceeded.

### Values:

<b>60 sec.*</b>	Specifies the amount of time the printer cancels for a job stops abnormally.
<b>3-300 sec.</b>	
<b>Off</b>	Disables the fault timeout.

## Time-Out

### Purpose:

To specify in seconds the amount of time the printer should wait for data to arrive from the computer. The print job is cancelled if the time-out time is exceeded.

**Values:**

<b>30 sec.*</b>	Specifies the amount of time the printer should wait for data to arrive from the computer.
<b>5-300 sec.</b>	
<b>Off</b>	Disables the job timeout.

## Panel Language

**Purpose:**

To determine the language of the text on the operator panel screen.

**Values:**

<b>English*</b>	<b>Français</b>
<b>Italiano</b>	<b>Deutsch</b>
<b>Español</b>	<b>Dansk</b>
<b>Nederlands</b>	<b>Norsk</b>
<b>Svenska</b>	

## Auto Log Print

**Purpose:**

To automatically print a log of completed jobs after every 20 jobs.

**Values:**

<b>Off*</b>	Does not automatically output a log of completed jobs.
<b>On</b>	Automatically outputs a log of completed jobs.

Print logs can also be printed using the `Report/List` menu.

 **NOTE:** Restart your printer when you change the settings for the `RAM Disk` menu.

## Print ID

**Purpose:**

To specify a location where the user ID is printed.

**Values:**

<b>Off*</b>	Does not print the user ID.
<b>Top Left</b>	Prints the user ID on the top left of the page.
<b>Top Right</b>	Prints the user ID on the top right of the page.
<b>Bottom Left</b>	Prints the user ID on the bottom left of the page.
<b>Bottom Right</b>	Prints the user ID on the bottom right of the page.

 **NOTE:** When printing on DL size paper, a part of the user ID may not be printed correctly.

## Print Text

**Purpose:**

To specify whether the printer outputs PDL data, which is not supported by the printer, as text when the printer receives it. Text data is printed on A4 or Letter size paper.

**Values:**

<b>On*</b>	Prints the received data as text data.
<b>Off</b>	Does not print the received data.

**Banner Sheet****Purpose:**

To specify the position of banner sheet, and also specify the tray in which the banner sheet is loaded. This feature is available for the PCL driver but is not available for the PS driver.

**Values:**

<b>Banner Sheet Insert Position</b>	<b>Off*</b>	Does not print the banner sheet.
	<b>Front</b>	Prints on the beginning of document.
	<b>Back</b>	Prints on the end of document.
	<b>Front &amp; Back</b>	Prints on both beginning and end of document.
<b>Banner Sheet Specify Tray</b>	<b>Tray 1*</b>	The banner sheet is loaded in tray 1.
	<b>Tray 2*<sup>1</sup></b>	The banner sheet is loaded in tray 2.
	<b>MPF</b>	The banner sheet is loaded in multipurpose feeder (MPF).
*1 Only displayed when an optional 550 sheet feeder is installed on the printer.		

**RAM Disk****Purpose:**

To allocate memory to the RAM disk file system for the Secure Print and Proof Print features. The change becomes effective after the printer is turned off and then on again.

**Values:**

<b>Disable*</b>	Does not allocate memory to the RAM disk file system. Secure Print and Proof Print jobs will abort and be recorded to the job log.
<b>50-500MB*1</b>	Specifies the amount of memory to allocate to the RAM disk file system. (50 MB step)
<b>50-1000MB*2</b>	
*1 Only displayed when the optional 512 MB memory is installed.	
*2 Only displayed when the optional 1024 MB memory is installed.	

 **NOTE:** The RAM Disk menu is displayed only when 512 MB or more memory is installed on the printer.

 **NOTE:** Restart your printer when you change the settings for the RAM Disk menu.

**Substitute Tray****Purpose:**

Specifies whether or not to use another size paper when the paper that is loaded in the specified tray does not match the paper size settings for the current job.

**Values:**

<b>Off*</b>	No tray size substitute accepted.
<b>Larger Size</b>	Substitutes paper of next largest size. When there is no larger paper size, the printer substitutes paper of nearest size.
<b>Nearest Size</b>	Substitutes paper of nearest size.
<b>MPF Feed</b>	Substitutes paper from the MPF.

**mm/inch****Purpose:**

Specifies the default measurement unit displayed after the numeric value on the operator panel.

**Values:**

<b>millimeter (mm)</b>	Selects millimeter as the default measurement unit.
<b>inch (")</b>	Selects inch as the default measurement unit.

 **NOTE:** The default for `mm/inch` varies depending on other settings, such as Country and Document Size.

**Odd Page 2Sided****Purpose:**

Specifies how the odd last page is printed when using duplex printing.

**Values:**

<b>1 Sided*</b>	Prints the odd last page upside down to the paper.
<b>2 Sided</b>	Prints the odd last page in normal direction to the paper.

**Maintenance**

Use the `Maintenance` menu to initialize the NV (non-volatile) memory, configure the plain paper quality adjustment settings, and configure the security settings.

 **NOTE:** Values marked by an asterisk (\*) are the factory default menu settings.

**F/W Version****Purpose:**

To display the printer's firmware version.

**Service Tag****Purpose:**

To display the printer's service tag.

**Paper Density****Purpose:**



To specify paper density settings.

**Values:**

Plain	Normal*
	Light
Label	Normal*
	Light

## Adjust BTR



**NOTICE:** The print quality changes depending on the setting values you select for this item.

**Purpose:**

To specify the transfer roller voltage adjustment for each paper type.

**Values:**

Plain	0*
	-3 - +3
Plain Thick	0*
	-3 - +3
Transparency	0*
	-3 - +3
Covers	0*
	-3 - +3
Covers Thick	0*
	-3 - +3
Label	0*
	-3 - +3
Coated	0*
	-3 - +3
Coated Thick	0*
	-3 - +3
Envelope	0*
	-3 - +3
Recycled	0*
	-3 - +3
JPN Coated	0*
	-3 - +3
Postcard JPN	0*
	-3 - +3

## Adjust Fuser



**NOTICE:** The print quality changes depending on the setting values you select for this item.

**Purpose:**

To adjust the fuser temperature setting for each paper type.

**Values:**

<b>Plain</b>	<b>0*</b>
	<b>-2 - +2</b>
<b>Plain Thick</b>	<b>0*</b>
	<b>-2 - +2</b>
<b>Transparency</b>	<b>0*</b>
	<b>-2 - +2</b>
<b>Covers</b>	<b>0*</b>
	<b>-2 - +2</b>
<b>Covers Thick</b>	<b>0*</b>
	<b>-2 - +2</b>
<b>Label</b>	<b>0*</b>
	<b>-2 - +2</b>
<b>Coated</b>	<b>0*</b>
	<b>-2 - +2</b>
<b>Coated Thick</b>	<b>0*</b>
	<b>-2 - +2</b>
<b>Envelope</b>	<b>0*</b>
	<b>-2 - +2</b>
<b>Recycled</b>	<b>0*</b>
	<b>-2 - +2</b>
<b>JPN Coated</b>	<b>0*</b>
	<b>-2 - +2</b>
<b>Postcard JPN</b>	<b>0*</b>
	<b>-2 - +2</b>

**Auto Reg Adj****Purpose:**

To specify whether to automatically perform color registration adjustment.

**Values:**

<b>On*</b>	Automatically performs color registration adjustment.
<b>Off</b>	Does not automatically perform color registration adjustment.

**Color Reg Adj****Purpose:**

To specify whether to manually perform color registration adjustment.

Manual Color Registration Adjustments are required such as when the printer is initially installed and after the printer is moved.

 **NOTE:** The Color Regi Adjust feature can be configured when Auto Reg Adjust is set to Off.

## Values:

<b>Auto Correct</b>	Automatically performs color registration correction.		
<b>ColorRegi Chart</b>	Prints a color registration chart. The color registration chart prints a lattice pattern of yellow, magenta, and cyan lines. On the chart, find the values on the right side that are next to the straightest lines for each of the three colors. If the value for the straightest line is 0, color registration adjustment is not required. If the value for the straightest line is any value other than 0, specify the adjustment values under <b>Enter Number</b> .		
<b>Enter Number</b>	<b>Y</b>	<b>-9-+9</b>	Specifies the values that are found in the color registration chart for Yellow.
	<b>M</b>	<b>-9-+9</b>	Specifies the values that are found in the color registration chart for Magenta.
	<b>C</b>	<b>-9-+9</b>	Specifies the values that are found in the color registration chart for Cyan.

## Adjust Altitude

### Purpose:

To specify the altitude of the location where the printer is installed.

The discharge phenomenon for charging the photo conductor varies with barometric pressure. Adjustments are performed by specifying the altitude of the location where the printer is being used.



**NOTICE:** An incorrect altitude adjustment setting leads to poor printing quality, incorrect indication of remaining toner, etc.

## Values:

<b>0m*</b>	Specifies the altitude of the location where the printer is installed.
<b>1000m</b>	
<b>2000m</b>	
<b>3000m</b>	

## Init PrintMeter

### Purpose:

To initialize the print meter of the printer. When the print meter is initialized, the meter count is reset to 0.

## Reset Defaults

### Purpose:

To initialize the NV (non-volatile) memory. After executing this function and rebooting the printer, all the menu parameters, except the parameters for the network, are reset to their default values.

## Clear Storage

### Purpose:

To clear all files that are stored as Secure, Store, and Proof Print in the optional hard disk.



**NOTE:** The **Clear Storage** menu is only displayed when an optional hard disk is installed on your printer.

## Format HDD

### Purpose:

To initialize the optional hard disk.

 **NOTE:** The `Format HDD` menu is only displayed when an optional hard disk is installed on your printer.

## Non-Dell Toner

### Purpose:

To specify whether or not to use another manufacturer's print cartridge.

 **NOTE:** Before you use another manufacturer's print cartridge, be sure to restart the printer.

 **NOTICE:** Use of a non-Dell print cartridge may result in some of the printer's functions to be unavailable, a reduction in print quality, or deterioration of printer's reliability. Use of a new Dell brand print cartridge is recommended for your printer. The Dell warranty does not cover any problems caused by the use of any accessory, part, or component that is not supplied by Dell.

### Values:

<b>Off*</b>	Does not use another manufacturer's print cartridge.
<b>On</b>	Uses another manufacturer's print cartridge.

## PCL

Use the `PCL` menu to change printer settings that only affect jobs using the PCL emulation printer language.

 **NOTE:** Values marked by an asterisk (\*) are the factory default menu settings.

## Paper Tray

### Purpose:

To specify the input tray.

### Values:

<b>Auto*</b>	Automatically selects a tray according to the paper size and type settings of the printing job.
<b>Tray 1</b>	The paper is fed from the tray 1.
<b>Tray 2*<sup>1</sup></b>	The paper is fed from the optional 550 sheet feeder.
<b>MPF</b>	The paper is fed from the MPF.
*1 Only displayed when an optional 550 sheet feeder is installed on the printer.	

## Paper Size

### Purpose:

To specify the default paper size.

### Values:

<b>A4*<sup>1</sup></b>	<b>A5</b>
<b>B5</b>	<b>Letter*<sup>1</sup></b>
<b>8.5x13"</b>	<b>Legal</b>
<b>Executive</b>	<b>Monarch</b>
<b>DL</b>	<b>C5</b>
<b>Envelope #10</b>	<b>Postcard JPN</b>

Youkei 2 Env	Youkei 3 Env
Youkei 4 Env	Youchou 3 Env
Choukei 3 Env	Custom Size
*1 Denotes country-specific factory default values.	

 **NOTE:** Selecting a custom size for the paper size prompts you to enter a custom length and width.

## Orientation

### Purpose:

To specify how text and graphics are oriented on the page.

### Values:

<b>Portrait*</b>	Prints text and graphics parallel to the short edge of the paper.
<b>Landscape</b>	Prints text and graphics parallel to the long edge of the paper.

## 2 Sided

### Purpose:

To set duplexing as the default for all print jobs. (Select **Duplex** from the printer driver to duplex only specific jobs.)

 **NOTE:** The 2 Sided menu is only available when the optional duplexer is installed on the printer.

### Values:

<b>2 Sided Print</b>	<b>Off*</b>	Prints on one side of the paper.
	<b>On</b>	Prints on both sides of the paper.
<b>Binding Edge</b>	<b>Flip Long Edge*</b>	Assumes binding along the long edge of the page. (Left edge for portrait orientation and top edge for landscape orientation)
	<b>Flip Short Edge</b>	Assumes binding along the short edge of the page. (Top edge for portrait orientation and left edge for landscape orientation)

## Font

### Purpose:

To specify the default font from the fonts registered in the printer.

### Values:

CG Times	CG Times It	CG Times Bd
CG Times BdIt	Univers Md	Univers MdIt
Univers Bd	Univers BdIt	Univers MdCd
Univers MdCdIt	Univers BdCd	Univers BdCdIt
AntiqueOlv	AntiqueOlv It	AntiqueOlv Bd
CG Omega	CG Omega It	CG Omega Bd
CG Omega BdIt	GaramondAntiqua	Garamond Krsv
Garamond Hlb	GaramondKrsvHlb	Courier*
Courier It	Courier Bd	Courier BdIt
LetterGothic	LetterGothic It	LetterGothic Bd

Albertus Md	Albertus XBd	Clarendon Cd
Coronet	Marigold	Arial
Arial It	Arial Bd	Arial Bdl t
Times New	Times New It	Times New Bd
Times New Bdl t	Symbol	Wingdings
Line Printer	Times Roman	Times It
Times Bd	Times Bdl t	Helvetica
Helvetica Ob	Helvetica Bd	Helvetica BdOb
CourierPS	CourierPS Ob	CourierPS Bd
CourierPS BdOb	SymbolPS	Palatino Roman
Palatino It	Palatino Bd	Palatino Bdl t
ITCBookman Lt	ITCBookman LtIt	ITCBookmanDm
ITCBookmanDm It	HelveticaNr	HelveticaNr Ob
HelveticaNr Bd	HelveticaNrBdOb	N C Schbk Roman
N C Schbk It	N C Schbk Bd	N C Schbk Bdl t
ITC A G Go Bk	ITC A G Go BkOb	ITC A G Go Dm
ITC A G Go DmOb	ZapfC Mdl t	ZapfDingbats

## Symbol Set

### Purpose:

To specify a symbol set for a specified font.

### Values:

ROMAN-8*	ISO L1	ISO L2
ISO L5	ISO L6	PC-8
PC-8 DN	PC-775	PC-850
PC-852	PC-1004	PC-8 TK
WIN L1	WIN L2	WIN L5
DESKTOP	PS TEXT	MC TEXT
MS PUB	MATH-8	PS MATH
PI FONT	LEGAL	ISO-4
ISO-6	ISO-11	ISO-15
ISO-17	ISO-21	ISO-60
ISO-69	WIN 3.0	WINBALT
SYMBOL	WINGDINGS	DNGBTSMS

## Font Size

### Purpose:

To specify the font size for scalable typographic fonts.

### Values:

12.00*	Specify the values in increments of 0.25.
4.00 - 50.00	

---

Font size refers to the height of the characters in the font. One point equals approximately 1/72 of an inch.

 **NOTE:** The `Font Size` menu is only displayed for typographic fonts.

**See also:**

["Pitch and Point Size"](#)

## Font Pitch

**Purpose:**

To specify the font pitch for scalable monospaced fonts.

**Values:**

10.00*	Specify the value in increments of 0.01.
6.00-24.00	

Font pitch refers to the number of fixed-space characters in a horizontal inch of type. For nonscalable monospaced fonts, the pitch is displayed, but cannot be changed.

 **NOTE:** The `Font Pitch` menu is only displayed for fixed or monospaced fonts.

**See also:**

["Pitch and Point Size"](#)

## Form Line

**Purpose:**

To set the number of lines in a page.

**Values:**

64* <sup>1</sup>	Specify the value in increments of 1.
5-128	
* <sup>1</sup> Denotes country-specific factory default values.	

The printer sets the amount of space between each line (vertical line spacing) based on the `Form Line` and `Orientation` menu items. Select the correct `Form Line` and `Orientation` before changing `Form Line`.

**See also:**

["Orientation"](#)

## Quantity

**Purpose:**

To set the default print quantity. (Set the number of copies required for a specific job from the printer driver. Values selected from the printer driver always override values selected from the operator panel.)

**Values:**

1*	Specify the value in increments of 1.
1-999	

## Image Enhance

**Purpose:**

To specify whether to perform the image enhancement feature. Image enhancement is a feature that makes the boundary line between black and white smoother to decrease jagged edges and enhance the visual appearance.

**Values:**

<b>On*</b>	Enables the Image Enhancement feature.
<b>Off</b>	Disables the Image Enhancement feature.

**Hex Dump****Purpose:**

To help isolate the source of a print job problem. With Hex Dump selected, all data sent to the printer is printed in hexadecimal and character representation. Control codes are not executed.

**Values:**

<b>Disable*</b>	Disables the Hex Dump feature.
<b>Enable</b>	Enables the Hex Dump feature.

**Draft Mode****Purpose:**

To save toner by printing in the draft mode. The print quality is reduced when printing in the draft mode.

**Values:**

<b>Disable*</b>	Does not print in the draft mode.
<b>Enable</b>	Prints in the draft mode.

**LineTermination****Purpose:**

To add the line termination commands.

**Values:**

<b>Off*</b>	The line termination command is not added. CR=CR, LF=LF, FF=FF
<b>Add-LF</b>	The LF command is added. CR=CR-LF, LF=LF, FF=FF
<b>Add-CR</b>	The CR command is added. CR=CR, LF=CR-LF, FF=CR-FF
<b>CR-XX</b>	The CR and LF commands are added. CR=CR-LF, LF=CR-LF, FF=CR-FF

**Default Color****Purpose:**

To specify the color mode to Color or Black. This setting is used for a print job which does not specify a print mode.

**Value:**

--	--



<b>Black</b>	Prints in the black and white mode.
<b>Color*</b>	Prints in the color mode.

## PostScript

Use the **PostScript** menu to change printer settings that only affect jobs using the PostScript emulation printer language.

 **NOTE:** Values marked by an asterisk (\*) are the factory default menu settings.

### PS Error Report

#### Purpose:

To specify whether the printer outputs error contents for a PostScript error. The change becomes effective after the printer is turned off and then on again.

#### Values:

<b>On*</b>	Prints an error message before it discards the job.
<b>Off</b>	Discards the print job without printing an error message.

 **NOTE:** This instructions from the PS driver override the settings specified on the operator panel.

### PS Job Time-Out

#### Purpose:

To specify the execution time for one PostScript job. The change becomes effective after the printer is turned off and then on again.

#### Values:

<b>Off*</b>	Job timeout does not occur.
<b>1-900min.</b>	A PostScript error occurs if processing is not completed after the specified time.

### Init PS Disk

#### Purpose:

To initialize the PostScript file system on the optional hard disk.

 **NOTE:** The `Init PS Disk` menu is only displayed when an optional hard disk is installed on your printer.

### PaperSelectMode

#### Purpose:

To specify the way to select the tray for PostScript mode. The change becomes effective after the printer is turned off and then on again.

#### Values:

<b>Auto*</b>	The tray is selected as the same setting as in the PCL mode.
<b>Select FromTray</b>	The tray is selected in a method compatible with regular Post Script printers.

### Default Color

**Purpose:**

To specify the color mode to Color or Black. This setting is used for a print job which does not specify a print mode.

**Value:**

<b>Black</b>	Prints in the black and white mode.
<b>Color*</b>	Prints in the color mode.

## Panel Settings

Use the Panel Settings menu to set a password to limit access to the menus. This prevents items from being changed accidentally.

 **NOTE:** Values marked by an asterisk (\*) are the factory default menu settings.

**See also:**

["Setting Panel Lock"](#)

### Panel Lock

**Purpose:**

To limit access to the menus.

**Values:**

<b>Disable*</b>	Does not limit access to the menus.
<b>Enable</b>	Limits access to the menus.

### Change Password

**Purpose:**

To set a password to limit access to the menus.

**Values:**

<b>0000*</b>	Sets or changes the password required to access Admin Menu.
<b>0000-9999</b>	

## Tray Settings

Use the Tray Settings menu to define the print media loaded in each tray.

 **NOTE:** Values marked by an asterisk (\*) are the factory default menu settings.

### MPF

**Purpose:**

To specify the paper loaded in the MPF.

**Values:**

	<b>Plain*</b>
--	---------------

<b>Paper Type</b>	<b>Plain Thick</b>
	<b>Transparency</b>
	<b>Covers</b>
	<b>Covers Thick</b>
	<b>Label</b>
	<b>Coated</b>
	<b>Coated Thick</b>
	<b>Envelope</b>
	<b>Recycled</b>
	<b>JPN Coated</b>
	<b>Postcard JPN</b>
	<b>Letterhead</b>
	<b>Preprinted</b>
	<b>Prepunched</b>
	<b>Color</b>
	<b>Plain S2</b>
	<b>Plain Thick S2</b>
	<b>Covers S2</b>
	<b>Covers Thick S2</b>
	<b>Coated S2</b>
	<b>Coated Thick S2</b>
	<b>Recycled S2</b>
	<b>JPN Coated S2</b>
	<b>Postcard JPN S2</b>
	<b>Color S2</b>
<b>Paper Size</b>	<b>A4</b>
	<b>A5</b>
	<b>B5</b>
	<b>Driver Size*</b>
	<b>Letter</b>
	<b>8.5x13"</b>
	<b>Legal</b>
	<b>Executive</b>
	<b>Monarch</b>
	<b>DL</b>
	<b>C5</b>
	<b>Envelope #10</b>
	<b>Postcard JPN</b>
	<b>Youkei 2 Env</b>
	<b>Youkei 3 Env</b>
	<b>Youkei 4 Env</b>
	<b>YouChou 3 Env</b>
	<b>Choukei 3 Env</b>

Custom Size		
MPF Mode	Driver Specified*	Continue to print even if the paper specified from the printer driver does not match the paper configured for the MPF from the operator panel.
	Panel Specified	Stop printing and show an error on the operator panel if the paper specified from the printer driver does not match the paper configured for the MPF from the operator panel.
Display Popup	On*	Specifies the size and type of paper loaded in the MPF. This item is available only when Panel Specified is selected for MPF Mode.
	Off	Size and type of paper loaded in the MPF is not specified. This item is available only when Panel Specified is selected for MPF Mode.

 **NOTE:** For the tray 1 or optional 550 sheet feeder, setting paper size is not required. These trays detect the paper size automatically. For more information on supported paper size for the standard and optional trays, see "[Supported Paper Sizes](#)."

**Use this menu item to:**

- Optimize print quality for the specified paper.
- Select paper source through your software program by selecting type and size.
- Automatically link trays. The printer automatically links any trays containing the same type and size of paper, if you have set the Paper Type to the correct values.

## Tray 1

**Purpose:**

To specify the paper loaded in the tray 1.

**Values:**

Paper Type	Plain*
	Plain Thick
	Covers
	Covers Thick
	Label
	Coated
	Coated Thick
	Recycled
	JPN Coated
	Letterhead
	Preprinted
	Prepunched
	Color
Paper Size	Auto*
	Custom Size

## Tray 2

**Purpose:**

To specify the paper loaded in the optional 550 sheet feeder.

**Values:**

---

Paper Type	Plain*
	Plain Thick
	Covers
	Covers Thick
	Label
	Coated
	Coated Thick
	Recycled
	JPN Coated
	Letterhead
	Preprinted
	Prepunched
	Color
Paper Size	Auto*
	Custom Size

## Stored Print

This **Stored Print** menu provides applicable printing services such as **Secure Print** and **Proof Print**.



**NOTE:** The **Stored Print** menu is displayed only when the optional hard disk, 512 MB or more memory is installed on the printer.

## Secure Print

### Purpose:

To print confidential jobs. The printer can hold the job in memory until you arrive at the printer and type the password on the operator panel.

### Values:

<b>Del after Print</b>	Prints the job, and then deletes it from print memory.
<b>Print and Save</b>	Prints the job, and then saves it in print memory.
<b>Delete</b>	Deletes the job from print memory.

## Proof Print

### Purpose:

To print only one copy and check the print result before printing all of the copies. This prevents a large number of misprinted copies from being printed at one time.

### Values:

<b>Del after Print</b>	Prints the job, and then deletes it from print memory.
<b>Print and Save</b>	Prints the job, and then saves it in print memory.
<b>Delete</b>	Deletes the job from print memory.

## Setting Panel Lock

This feature prevents unauthorized personnel from changing settings made by the administrator. For regular printing, items can be selected from the menu and printer settings remain unchanged. For regular printing, items can be configured using the printer driver.

 **NOTE:** Disabling the operator panel menus does not prevent access to the Stored Print and Tray Settings menus.

1. Press **Menu** button.
2. Press ▼ button until Admin Menu appears, and then press ✓ (Set) button.
3. Press ▼ button until Panel Settings appears, and then press ✓ (Set) button.
4. Panel Lock is displayed. Press ✓ (Set) button.
5. Press ▼ button until Enable appears, and then press ✓ (Set) button.
6. Press ◀ button.
7. Press ▼ button until Change Password appears, and then press ✓ (Set) button.
8. Enter the old password (when you enter it for the first time after doing the settings, enter 0000), and then press ✓ (Set) button.
9. Enter the new password, and then press ✓ (Set) button.
10. Reenter the password to confirm the password that you entered, and then press ✓ (Set) button.  
The Password has been changed.

 **NOTE:** If you forget your password, turn off the printer. Then, while holding **Menu** button, turn on the printer. Continue to hold **Menu** button until the display indicates Init Password Are you sure? Release **Menu** button and press ✓ (Set) button. Press ◀ button to select Yes, then press ✓ (Set) button. The display will briefly indicate Password reset. This will recover the factory default panel password.

 **NOTE:** If panel lock is Enable, the factory-default panel password is 0000.

**See also:**

["Change Password"](#)

## Disabling Panel Lock

1. Press **Menu** button.
2. Press ▼ button until Admin Menu appears, and then press ✓ (Set) button.
3. Enter the password, and then press ✓ (Set) button.
4. Press ▼ button until Panel Settings appears, and then press ✓ (Set) button.
5. Panel Lock is displayed. Press ✓ (Set) button.
6. Press ▼ button until Disable appears, and then press ✓ (Set) button.

---

[Back to Contents Page](#)

# Understanding Your Printer Software

## [Printer Settings Utility](#)

Use the *Drivers and Utilities* CD that came with your printer to install a combination of software programs, depending on your operating system.

The following software programs can only operate on Windows. They cannot operate on Macintosh, UNIX, or Linux.

## Printing Status Window

The **Printing Status Window** alerts you when an error or warning occurs, for example, when a paper jam occurs or toner is running low.

The **Printing Status Window** always launches when printing. When an error occurs, the error message appears on the **Printing Status Window**.

You can also check toner level, quantity of paper remaining or the configuration of options for the local printer.

## Status Monitor Console

Use the **Status Monitor Console** to manage multiple **Status Window**.

- Select a printer from the list view (or **Printer Selection**) by clicking its name to open a **Status Window** for a particular printer.
- The **Status Monitor Console** displays the **Status Window** for local and network connections.

## Dell Supplies Management System™

You can launch the **Dell Supplies Management System** dialog box from the **Printing Status** window, the **All Programs** menu, or the desktop icon. You can also launch it from the **Status Window** when a toner error occurs.

You can order consumables by phone or from the web.

1. Click **start® All Programs® Dell Printers® Additional Color Laser Software® Dell Supplies Management System**.

The **Dell Supplies Management System** window appears.

2. Select your printer from the **Select Printer Model** list.
3. If you are ordering from the Web:
  - a. When you cannot get information from the printer automatically by two-way communication, a window that prompts you to type the Service Tag number appears. Type your Dell printer Service Tag number in the field provided.

Your Service Tag number is located inside the front cover of your printer.

- b. Select a URL from the **Select Reorder URL** list.
  - c. Click **Visit Dell printer supplies ordering web site**.
4. If ordering by phone, call the number that appears under the **Order by Phone** heading.

## User Setup Disk Creating Tool

The **User Setup Disk Creating Tool** program located in the **MakeDisk** folder of the **Utilities** folder on the *Drivers and Utilities* CD and the printer drivers located on the *Drivers and Utilities* CD are used to create driver installation packages that contain custom driver settings. A driver installation package can contain a group of saved printer driver settings and other data for things such as:

- Print orientation and Multiple Up (document settings)
- Watermarks
- Font references

If you want to install the printer driver with the same settings to multiple computers running the same operating system, create a setup disk in a floppy disk or in a server on the network. Using the setup disk that you have created will reduce the amount of work required when installing the printer driver.

- Install in advance the Dell™ 3130cn Color Laser Printer printer driver in the computer on which the setup disk is to be created.
- The setup disk can only be used on the operating system on which the disk was created or computers running the same operating system. Create a separate setup disk for different types of operating systems.

## Software Update

The firmware and/or driver updates can be downloaded from the Dell Support website located at [support.dell.com](http://support.dell.com).

---

## Printer Settings Utility

Using the **Quick Launch Utility** window, you can open **Status Window**, **Tool Box**, **Updater**, and **Troubleshooting**.

When you install the Dell software, the **Quick Launch Utility** is automatically installed.

For information about installing the software, see "[Setting Up for Shared Printing](#)".

To open the **Quick Launch Utility** window:

1. Click **start**® **All Programs**® **Dell Printers**® **Additional Color Laser Software**® **Quick Launch Utility**.

The **Quick Launch Utility** dialog box opens.

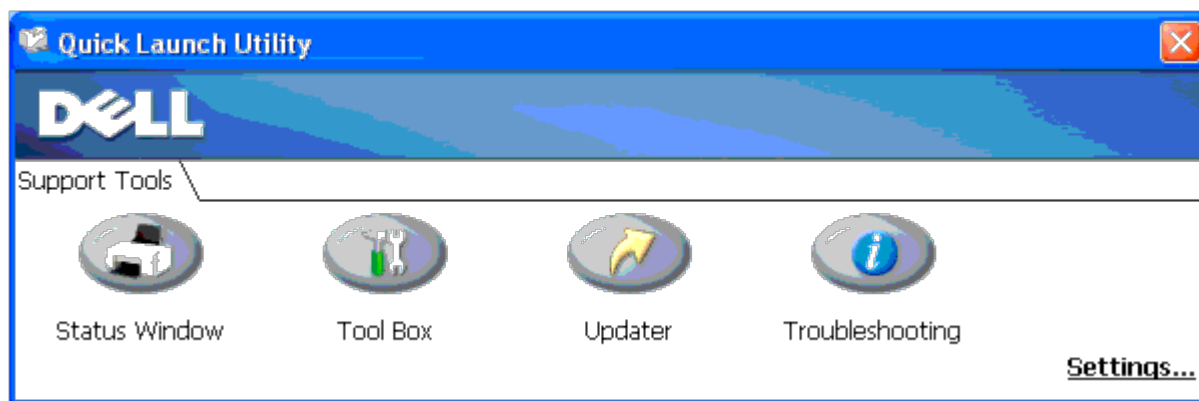

2. The **Quick Launch Utility** window provides four buttons; **Status Window**, **Tool Box**, **Updater**, and **Troubleshooting**.

To exit, click the X button at the top-right of the window.

For details, click the **Help** button of each application.

## Status Window



The **Status Window** button opens the **Printing Status** Window. See "[Printing Status Window](#)".

## Tool Box

You can use the **Tool Box** to specify various settings for the printer. See "[Understanding the Tool Box Menus](#)."

## Updater

The **Updater** button updates the settings for the printer driver.

## Troubleshooting

The **Troubleshooting** button opens the Troubleshooting Guide, which allows you to recover problems by yourself.

---

[Back to Contents Page](#)

# Printing

- [Tips for Successful Printing](#)
- [Sending a Job to Print](#)
- [Canceling a Print Job](#)
- [Printing a Report Page](#)
- [Using the Print and Hold Function](#)

This chapter covers tips for printing, how to print certain lists of information from your printer, and how to cancel a job.

---

## Tips for Successful Printing

### Tips on Storing Print Media

Store your print media properly. For more information, see "[Storing Print Media](#)".

### Avoiding Paper Jams

 **NOTE:** It is recommended that you try a limited sample of any print media you are considering using with the printer before purchasing large quantities.

By selecting appropriate print media and loading it properly, you can avoid paper jams. See the following instructions on loading print media:

- "[Loading Print Media in the Standard and Optional Trays](#)" (which includes the tray 1 and the optional 550 sheet feeder)
- "[Loading the MPF](#)"
- "[Avoiding Jams](#)"

If you experience a jam, see "[Clearing Jams](#)" for instructions.

---

## Sending a Job to Print

To support all of the printer features, use the printer driver. When you choose **Print** from a software program, a window representing the printer driver opens. Select the appropriate settings for the specific job you are sending to print. Print settings selected from the driver override the default menu settings selected from the operator panel or Tool Box.

You may need to click **Preferences** from the initial **Print** box to see all of the available system settings you can change. If you are not familiar with a feature in the printer driver window, open the online Help for more information.

To print a job from a typical Windows® application:

1. Open the file you want to print.
2. From the **File** menu, select **Print**.
3. Verify that the correct printer is selected in the dialog box. Modify the printer settings as appropriate (such as the pages you want to print or the number of copies).
4. Click **Preferences** to adjust system settings not available from the first screen, and then click **OK**.
5. Click **OK** or **Print** to send the job to the selected printer.

---

## Canceling a Print Job

There are several methods for canceling a print job.

### Canceling From the Operator Panel

To cancel a job after it has started printing:

1. Press **Cancel**.

Printing is canceled only for the current job. All the following jobs will continue to print.

### Canceling a Job From the Computer Running Windows

#### Canceling a Job From the Taskbar

When you send a job to print, a small printer icon appears in the right corner of the taskbar.

1. Double-click the printer icon.

A list of print jobs appears in the printer window.

2. Select the job you want to cancel.
3. Press **Delete** on the keyboard.

#### Canceling a Job From the Desktop

1. Minimize all programs to reveal the desktop.

Click **start**® **Printers and Faxes**.

Click **Start**® **Devices and Printers** (for Windows 7 and Windows Server® 2008 R2).

Click **start**® **Control Panel**® **Hardware and Sound**® **Printers** (for Windows Vista®).

Click **start**® **Control Panel**® **Printers** (for Windows Server 2008).

Click **start**® **Settings**® **Printers** (for Windows 2000/NT® 4.0).

A list of available printers appears.

2. Double-click the printer you selected when you sent the job.

A list of print jobs appears in the printer window.

3. Select the job you want to cancel.
4. Press **Delete** on the keyboard.

---

## Printing a Report Page

By using the **Report** menu, you can print a various of settings for your printer including printer settings, panel setting,

and font list. The following describes two examples of printing from the **Report** menu.

## Printing a Printer Settings Page

To verify detailed printer settings, print a printer settings page. A printed printer settings page also allows you to verify whether or not options have been installed properly.

See "[Understanding the Printer Menus](#)" or "[Understanding the Tool Box Menus](#)" to identify the display and operator panel buttons if you need help.

## When Using the Operator Panel

1. Press **Menu** button.
2. Press ▼ button until `Report/List` appears, and then press ✓ (**Set**) button.
3. `Printer Setting` is displayed, and then press ✓ (**Set**) button.  
The printer settings page is printed.

## When Using the Tool Box

1. Click **start® All Programs® Dell Printers® Dell 3130cn Color Laser Printer® Tool Box**.

The **Select Printer** dialog box opens.

2. Click **Dell 3130cn Color Laser PCL 6** listed in **Printer Name**, and then click **OK**.

The **Tool Box** opens.

3. Click the **Printer Settings Report** tab.
4. Select **Reports** from the list at the left side of the page.

The **Reports** page is displayed.

5. Click the **Printer Settings** button.

The printer settings page is printed.

The message `Printer Settings Printing` appears while the page prints. The printer returns to the standby mode after the printer settings page prints.

If any other message appears when you print this page, see the online Help for more information.

## Printing a Font Sample List

To print samples of all the fonts currently available for your printer:

## When Using the Operator Panel

1. Press **Menu** button.
2. Press ▼ button until `Report/List` appears, and then press ✓ (**Set**) button.
3. Press ▼ button until either `PCL Fonts List` or `PS Fonts List` appears.
  - Select `PCL Fonts List` to print a listing of the fonts available to the PCL.

- Select **PS Fonts List** to print a listing of the fonts available to the PostScript® 3™.





4. Press  **(Set)** button.

The message **PCL Fonts List Printing** OR **PS Fonts List Printing** appears and remains on the operator panel until the page prints. The printer returns to the **Ready to Print** state after the font sample list prints.

---

## Using the Print and Hold Function

When you send a job to the printer, you can specify in the driver that you want the printer to hold the job in memory. When you are ready to print the job, you must go to the printer and use the operator panel menus to identify which job in the memory or hard disk you want to print. You can use this function to print a confidential job (**Secure Print**), or verify one copy before printing additional copies (**Proof Print**).

-  **NOTE:** The printer holds the job until you delete it by using the operator panel or you turn off the printer. The data on memory is cleared when the printer is turned off. The data on the optional hard disk is not cleared even when the printer is turned off.
-  **NOTE:** Print and Hold functions require a minimum of 512 MB available printer memory or hard disk. Also, you need to configure the RAM disk settings on the operator panel and the printer driver.
-  **NOTE:** Depending on the documents, its job may be too big for the available memory. In this case, an error occurs.
-  **NOTE:** If a document name is not assigned to your print job in the printer driver, the job's name will be identified using the PC's time and date of submission to distinguish it from other jobs you have stored under your name.

## Printing and Deleting Held Jobs

Once held jobs are stored in print memory or hard disk, you can use the operator panel to specify what you want to do with one or more of the jobs. You can select either **Secure Print** or **Proof Print** from "**Stored Print**". Then, you select your user name from a list. If you select **Secure Print**, you must type the password you specified in the driver when you sent the job. See "**Secure Print**" for more information.





From either the **Secure Print** or **Proof Print** menu items, you have three choices:

- Print and Save
- Del after Print
- Delete

-  **NOTE:** To send a job to print as **Secure Printing** or **Proof Printing**, select **Secure Print** or **Proof Print** in **Job Type** in the **Paper/Output** tab of the **Printing Preferences** dialog box.

## Printing Held and Proof Print Jobs

### When Using the Operator Panel

1. Press **Menu** button.
2. Press  button until **Report/List** appears, and then press  **(Set)** button.
3. Press  button until either **Stored Document** appears, and then press  **(Set)** button. The stored documents page is printed.

## Stored Print

If you send a Stored Print job, the printer does not print the job immediately, but stores the job in memory or hard disk so you can print the job later. See "[Printing and Deleting Held Jobs](#)" for more information.

 **NOTE:** The printer holds the job until you delete it by using the operator panel or you turn off the printer.

 **NOTE:** When you select `Del` after `Print`, the held job is automatically deleted after printing.

## Proof Print

If you send a Proof Print job, the printer prints one copy and holds the remaining copies you requested from the driver in print memory or hard disk. Use Proof Print function to examine the first copy to see if it is satisfactory before printing the remaining copies.

See "[Printing and Deleting Held Jobs](#)" if you need help printing the additional copies stored in memory or hard disk.

 **NOTE:** The printer holds the job until you delete it by using the operator panel or you turn off the printer. The data on memory is cleared when the printer is turned off. The data on the optional hard disk is not cleared even when the printer is turned off.

 **NOTE:** When you select `Del` after `Print`, the held job is automatically deleted after printing.

## Secure Print

When you send a job to the printer, you can specify a password from the driver. The password must be between 0 and 12 digits using numbers 0-9. The job is then held in print memory or hard disk until you enter the same numeric password from the operator panel and choose to print or delete the job. This function is called "[Stored Print](#)". This ensures that the job does not print until you are there to retrieve it, and no one else using the printer can print the job.

When you select `Secure Print` from `Stored Print` after selecting your user name, the following prompt is displayed:

[ \*\*\*\*\* ]

Use the buttons on the operator panel to enter the numeric password associated with your confidential job. As you enter the password, the password you entered is displayed to ensure confidentiality.

If you enter an invalid password, the message `Wrong Password` appears. Wait three seconds, or Press  **(Set)** or **Cancel** button to return to the screen for user selection.

When you enter a valid password, you have access to all print jobs matching the user name and password you entered. The print jobs matching the password you entered appear on the screen. You can then choose to print or delete jobs matching the password you entered. (See "[Printing and Deleting Held Jobs](#)" for more information.)

 **NOTE:** The printer holds the job until you delete it by using the operator panel or you turn off the printer. The data on memory is cleared when the printer is turned off. The data on the optional hard disk is not cleared even when the printer is turned off.

 **NOTE:** When you select `Del` after `Print`, the held job is automatically deleted after printing.

---

[Back to Contents Page](#)

## Setting Up for Shared Printing

- [Point and Print](#)
- [Peer-to-Peer](#)

You can share your new printer on the network using the *Drivers and Utilities* CD that shipped with your printer, or using Microsoft® point and print or peer-to-peer method. However, if you use one of the Microsoft methods, you will not have all the features, such as the status monitor and other printer utilities, that are installed with the *Drivers and Utilities* CD.

To share a locally-attached printer on the network, you need to share the printer, and then install the shared printer on network clients:

 **NOTE:** The following are options you need to buy separately for shared printing.

- Ethernet cable

### Windows® XP, Windows XP 64-bit Edition, Windows Server® 2003, Windows Server 2003 x64 Edition, Windows 2000, Windows NT® 4.0

1. Click **start® Printers and Faxes** (**Printers** for Windows 2000).
2. Right-click this printer icon and select **Properties**.
3. From the **Sharing** tab, check the **Share this printer** (**Share as** for Windows 2000) check box, and then type a name in the **Share name** (**Share as** for Windows 2000) text box.
4. Click **Additional Drivers** and select the operating systems of all network clients printing to this printer.
5. Click **OK**.

If you are missing files, you will be prompted to insert the server operating system CD.

### Windows Vista®, Windows Vista 64-bit Edition

1. Click **start® Control Panel® Hardware and Sound® Printers**.
2. Right-click this printer icon and select **Sharing**.
3. Click **Change sharing options** button.
4. The dialog box displaying "Windows needs your permission to continue" appears.
5. Click **Continue** button.
6. Check the **Share this printer** check box, and then type a name in the **Share name** text box.
7. Click **Additional Drivers** and select the operating systems of all network clients printing to this printer.
8. Click **OK**.

### Windows Server 2008, Windows Server 2008 64-bit Edition

1. Click **start® Control Panel® Printers**.
2. Right-click this printer icon and select **Sharing**.
3. Click **Change Sharing Options** button if exists.

Check the **Share this printer** check box, and then type a name in the **Share name** text box.

4. Click **Additional Drivers** and select the operating systems of all network clients printing to this printer.
5. Click **OK**.

### Windows 7, Windows 7 64-bit Edition, Windows Server 2008 R2 64-bit Edition

1. Click **Start® Devices and Printers**.
2. Right-click the printer icon and select **Printer properties**.

3. From the **Sharing** tab, click **Change Sharing Options** button if exists.

Check the **Share this printer** check box, and then type a name in the **Share name** text box.

4. Click **Additional Drivers** and select the operating systems of all network clients printing to this printer.
5. Click **Apply**, and then click **OK**.

To check that the printer is successfully shared:

- Ensure that the printer object in the **Printers**, **Printers and Faxes**, or **Devices and Printers** folder is shared. A icon of sharing is shown underneath the printer icon.
- Browse **Network** or **My Network Places**. Find the host name of the server and look for the shared name you assigned to the printer.

Now that the printer is shared, you can install the printer on network clients using the point and print method or the peer-to-peer method.

---

## Point and Print

This method is usually the best use of system resources. The server handles driver modifications and print job processing. This lets network clients return to their programs much faster.

If you use the point and print method, a subset of driver information is copied from the server to the client computer. This is just enough information to send a print job to the printer.

## Windows XP, Windows XP 64-bit Edition, Windows Server 2003, Windows Server 2003 x64 Edition, Windows 2000, Windows NT 4.0

1. On the Windows desktop of the client computer, double-click **My Network Places**.
2. Locate the host name of the server computer, and then double-click the host name.
3. Right-click the shared printer name, and then click **Connect**.

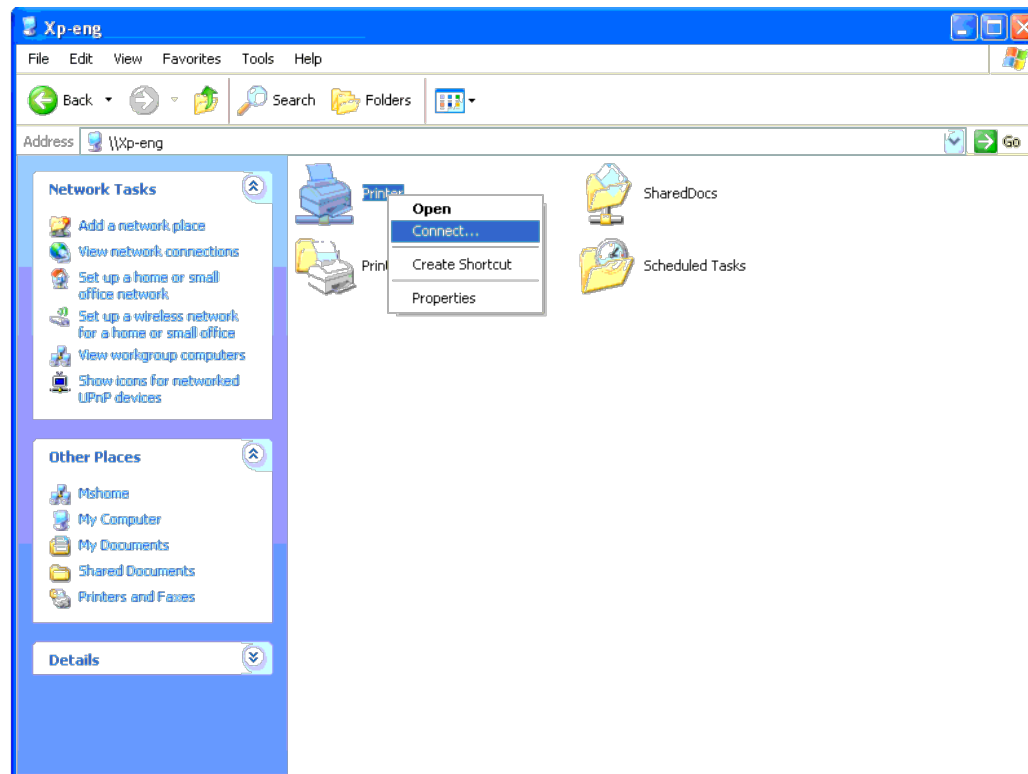

Wait for the driver information to copy from the server computer to the client computer, and for a new printer object to be added to the **Printers and Faxes** (**Printers** for Windows 2000) folder. The copy time varies, based on network traffic and other



factors.

Close **My Network Places**.

4. Print a test page to verify installation.
  - a. Click **start**® **Printers and Faxes** (**Printers** for Windows 2000).
  - b. Select the printer you just created.
  - c. Click **File**® **Properties**.
  - d. From the **General** tab, click **Print Test Page**.

When a test page prints successfully, installation is complete.

## Windows Vista, Windows Vista 64-bit Edition

1. On the Windows desktop of the client computer, click **start**® **Network**.
2. Locate the host name of the server computer, and then double-click the host name.
3. Right-click the shared printer name, and then click **Connect**.
4. Click **Install driver**.
5. Click **Continue** in **User Account Control** dialog.
6. Wait for the driver information to copy from the server computer to the client computer, and for a new printer object to be added to the **Printers** folder. The time this takes varies, based on network traffic and other factors.
7. Print a test page to verify installation.
  - a. Click **start**® **Control Panel**® **Hardware and Sound**.
  - b. Select **Printers**.
  - c. Right-click the printer you just created and select **Properties**.
  - d. From the **General** tab, click **Print Test Page**.

When a test page prints successfully, installation is complete.

## Windows Server 2008, Windows Server 2008 64-bit Edition

1. On the Windows desktop of the client computer, click **start**® **Network**.
2. Locate the host name of the server computer, and then double-click the host name.
3. Right-click the shared printer name, and then click **Connect**.
4. Click **Install driver**.
5. Wait for the driver information to copy from the server computer to the client computer, and for a new printer object to be added to the **Printers** folder. The time this takes varies, based on network traffic and other factors.
6. Print a test page to verify installation.
  - a. Click **start**® **Control Panel**.
  - b. Select **Printers**.
  - c. Right-click the printer you just created and select **Properties**.
  - d. From the **General** tab, click **Print Test Page**.

When a test page prints successfully, installation is complete.

## Windows 7, Windows 7 64-bit Edition, Windows Server 2008 R2 64-bit Edition

1. On the Windows desktop of the client computer, click **Start**® your user name® **Network** (**Start**® **Network** for Windows Server 2008 R2).
2. Locate the host name of the server computer, and then double-click the host name.
3. Right-click the shared printer name, and then click **Connect**.

4. Click **Install driver**.
5. Wait for the driver information to copy from the server computer to the client computer, and for a new printer object to be added to the **Devices and Printers** folder. The time this takes varies, based on network traffic and other factors.
6. Print a test page to verify installation.
  - a. Click **Start** @ **Devices and Printers**.
  - b. Right-click the printer you just created and select **Printer properties**.
  - c. From the **General** tab, click **Print Test Page**.

When a test page prints successfully, installation is complete.

## Peer-to-Peer

If you use the peer-to-peer method, the printer driver is fully installed on each client computer. Network clients retain control of driver modifications. The client computer handles the print job processing.

## Windows XP, Windows XP 64-bit Edition, Windows Server 2003, Windows Server 2003 x64 Edition, Windows 2000, Windows NT 4.0

1. Click **start** @ **Printers and Faxes** (**Printers** for Windows 2000).
2. Click **Add a Printer** to launch the **Add Printer** wizard.
3. Click **Next**.
4. Select **A network printer, or a printer attached to another computer**, and then click **Next** (For Windows 2000, select the network printer from the **Shared printers** list). If the printer is not listed, type in the path of the printer in the text box.

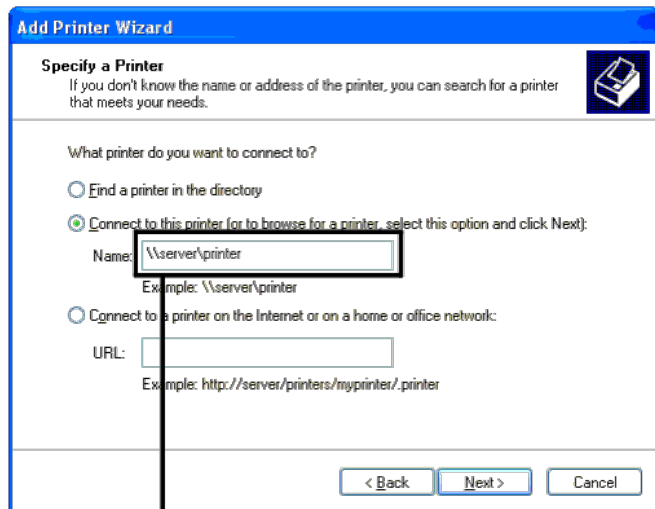

For example: \\<server host name>\<shared printer name>

The server host name is the name of the server computer that identifies it to the network. The shared printer name is the name assigned during the server installation process.

5. Click **Browse for a printer**, and then click **Next** (For Windows 2000, click **OK**).

If this is a new printer, you may be prompted to install a printer driver. If no system driver is available, then you will need to provide a path to available drivers.

6. Select whether you want this printer to be the default printer for the client, click **Next**, and then click **Finish** (For Windows 2000, click **Finish**).
7. Print a test page to verify installation:

- a. Click **start**® **Settings**® **Printers and Faxes (Printers for Windows 2000)**.
- b. Select the printer you just created.
- c. Click **File**® **Properties**.
- d. From the **General** tab, click **Print Test Page**.

When a test page prints successfully, installation is complete.

## Windows Vista, Windows Vista 64-bit Edition

1. Click **start**® **Control Panel**® **Hardware and Sound**® **Printers**.
2. Click **Add a Printer** to launch the **Add Printer** wizard.
3. Select **Add a network, wireless or Bluetooth printer**, and then click **Next**. If the printer is listed, select the printer and click **Next**, or select **The printer that I want isn't listed** and type in the path of the printer in the **Select a shared printer by name** text box and click **Next**.

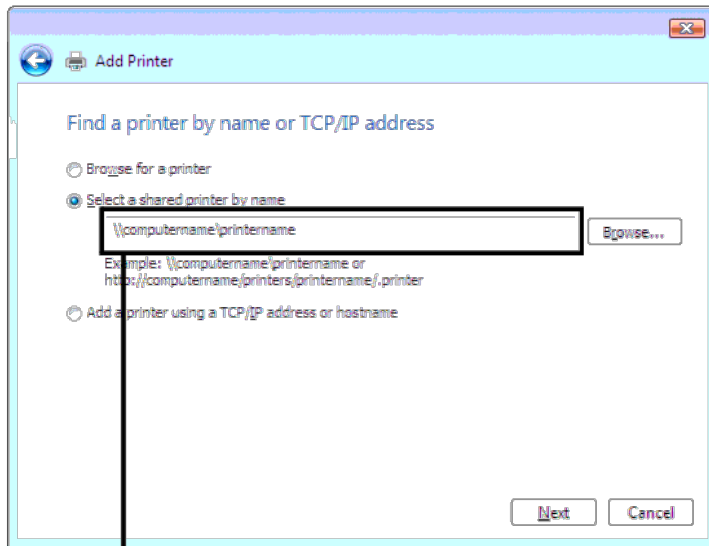

For example: \\<server host name>\<shared printer name>

The server host name is the name of the server computer that identifies it to the network. The shared printer name is the name assigned during the server installation process.

4. If this is a new printer, you may be prompted to install a printer driver. If no system driver is available, then you will need to provide a path to available drivers.
5. Select whether you want this printer to be the default printer for the client, click **Next**.
6. If you want to verify installation then click **Print a test page**.
7. Click **Finish**.

When a test page prints successfully, installation is complete.

## Windows Server 2008, Windows Server 2008 64-bit Edition

1. Click **start**® **Control Panel**® **Printers**.
2. Click **Add a Printer** to launch the **Add Printer** wizard.

3. Select **Add a network, wireless or Bluetooth printer**, and then click **Next**. If the printer is listed, select the printer and click **Next**, or select **The printer that I want isn't listed** and type in the path of the printer in the **Select a shared printer by name** text box and click **Next**.

For example: \\<server host name>\<shared printer name>

The server host name is the name of the server computer that identifies it to the network. The shared printer name is the name assigned during the server installation process.

4. If this is a new printer, you may be prompted to install a printer driver. If no system driver is available, then you will need to provide a path to available drivers.
5. Select whether you want this printer to be the default printer for the client, click **Next**.
6. If you want to verify installation then click **Print a test page**.
7. Click **Finish**.

When a test page prints successfully, installation is complete.

## Windows 7, Windows 7 64-bit Edition, Windows Server 2008 R2 64-bit Edition

1. Click **Start® Devices and Printers**.
2. Click **Add a Printer** to launch the **Add Printer** wizard.
3. Select **Add a network, wireless or Bluetooth printer**. If the printer is listed, select the printer and click **Next**, or select **The printer that I want isn't listed**. Click **Select a shared printer by name** and type in the path of the printer in the text box, and then click **Next**.

For example: \\<server host name>\<shared printer name>

The server host name is the name of the server computer that identifies it to the network. The shared printer name is the name assigned during the server installation process.

4. If this is a new printer, you may be prompted to install a printer driver. If no system driver is available, then you will need to provide the path to the available drivers.
5. Confirm the printer name, and then click **Next**.
6. Select whether you want this printer to be the default printer for the client.
7. If you want to verify installation then click **Print a test page**.
8. Click **Finish**.

When a test page prints successfully, installation is complete.

---

[Back to Contents Page](#)

# Understanding Fonts

- [Typefaces and Fonts](#)
- [Bitmapped and Scalable Fonts](#)
- [Resident Fonts](#)
- [Symbol Sets](#)

---

## Typefaces and Fonts

A font is a set of characters and symbols created with a distinct design. The distinct design is called a *typeface*. The typefaces you select add personality to a document. Well-chosen typefaces make a document easier to read.

The printer has numerous resident fonts in PCL 5/PCL 6 and PostScript 3. See "[Resident Fonts](#)" for a listing of all resident fonts.

## Weight and Style

Typefaces are often available in different weights and styles. These variations modify the original typeface so you can, for example, emphasize important words in text or highlight book titles. The different weights and styles are designed to complement the original typeface.

*Weight* refers to the thickness of the lines that form the characters. Thicker lines result in darker characters. Some words commonly used to describe the weight of a typeface are bold, medium, light, black, and heavy.

*Style* refers to other typeface modifications, such as tilt or character width. Italic and oblique are styles where the characters are tilted. Narrow, condensed, and extended are three common styles that modify the character widths.

Some fonts combine several weight and style modifications; for example, Helvetica BdOb. A group of several weight and style variations of a single typeface is called a *typeface family*. Most typeface families have four variations: regular, italic (oblique), bold, and bold italic (bold oblique). Some families have more variations, as the following illustration for the Helvetica typeface family shows:

Helvetica	ABCDEFGHIJKLMNOabcdefghijklmno1234567890
Helvetica Oblique	ABCDEFGHIJKLMNOabcdefghijklmno1234567890
Helvetica Bold	ABCDEFGHIJKLMNOabcdefghijklmno1234567890
Helvetica Bold Oblique	ABCDEFGHIJKLMNOabcdefghijklmno1234567890
Helvetica Narrow	ABCDEFGHIJKLMNOabcdefghijklmno1234567890
Helvetica Narrow Oblique	ABCDEFGHIJKLMNOabcdefghijklmno1234567890
Helvetica Narrow Bold	ABCDEFGHIJKLMNOabcdefghijklmno1234567890
Helvetica Narrow Bold Oblique	ABCDEFGHIJKLMNOabcdefghijklmno1234567890

## Pitch and Point Size

The size of a font is specified as either a pitch or point size, depending on whether the font is fixed space or proportional.

In *fixed space* fonts, each character has the same width. *Pitch* is used to specify the size of fixed space fonts. It is a measure of the number of characters that will print in one horizontal inch of type. For example, all 10-pitch fonts print 10 characters per inch (cpi) and all 12-pitch fonts print 12 cpi:

Courier	10 Pitch	1234567890
<b>Courier-Bold</b>	<b>10 Pitch</b>	<b>1234567890</b>
Courier	12 Pitch	123456789012
<b>Courier-Bold</b>	<b>12 Pitch</b>	<b>123456789012</b>

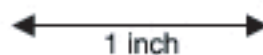

In *proportional* (or *typographic*) fonts, every character can have a different width. Since proportional fonts have characters with different widths, the font size is specified in point size, not pitch. *Point size* refers to the height of the characters in the font. A *point* is defined as 1/72 inch. The characters in a font printed at 24 point will be twice as large as the characters in the same font printed at 12 point.

The following illustration shows samples of a font printed in different point sizes:

48 point 36 point

24 point 18 point 12 point 10 point

The point size of a font is defined as the distance from the top of the tallest character in the font to the bottom of the lowest character in the font. Due to the definition of point size, different fonts printed at the same point size may appear quite different in size. This is because there are other font parameters that affect how the font looks. However, the point size of a font is an excellent specification of the relative size of a font. The following examples illustrate two very different proportional fonts at 14 point:

ITC Avant Garde  
abcdefghijklmnop ABCDEFGH  
*ITC Zapf Chancery*  
*abcdefghijklmnop ABCDEFGH*

---

## Bitmapped and Scalable Fonts

The printer uses both bitmapped and scalable fonts.

*Bitmapped* fonts are stored in print memory as predefined patterns of bits that represent a typeface at a specific size, style, and resolution. The following illustration shows an example of a character from a bitmapped font.



Bitmapped fonts are available in different type styles and point sizes as downloadable fonts.

*Scalable* fonts (also called *outline* fonts) are stored as computer programs that define the outlines of the characters in the font. Each time you print characters from a scalable font, the printer creates a bitmap of the characters at the point size you choose and saves it temporarily in print memory.



**P P P P**

These temporary bitmapped fonts are deleted when you turn off or reset the printer. Scalable fonts provide the flexibility of printing in many different point sizes.

Your printer uses different scalable font formats for downloading fonts to the printer. PCL 5/PCL 6 uses Intellifont and TrueType scalable fonts. PostScript 3 uses Type 1 and TrueType scalable fonts. There are thousands of different scalable fonts available in these different font formats from numerous font suppliers.

If you plan to use many downloadable bitmapped or scalable fonts or if you plan to use many different sizes of scalable fonts, you may need to purchase additional memory for your printer.

## Resident Fonts

Your printer is equipped with resident fonts stored permanently in print memory. Different fonts are available in PCL 5/PCL 6 and PostScript 3. Some of the most popular typefaces, like Courier and TimesNew (PCL 5/PCL 6)/Times New Roman (PostScript 3), are available for all printer languages.

The following table lists all the fonts resident in your printer. See "[Printing a Font Sample List](#)" for instructions on how to print samples of the fonts. You can select the resident fonts from your software program. You can also select the fonts from the operator panel if you are using PCL 5.

Resident scalable fonts	
PCL 5/PCL 6	PostScript 3
CG Times	Albertus
CG Times It	Albertus Italic
CG Times Bd	Albertus Light
CG Times BdIt	
	Antique Olive Roman
Univers Md	Antique Olive Italic
Univers MdIt	Antique Olive Bold
Univers Bd	Antique Olive Compact
Univers BdIt	Apple Chancery
Univers MdCd	Arial
Univers MdCdIt	Arial Italic
Univers BdCd	Arial Bold
Univers BdCdIt	Arial Bold Italic
	ITC Avant Garde Gothic Book
AntiqueOlv	ITC Avant Garde Gothic Book Oblique
AntiqueOlv It	ITC Avant Garde Gothic Demi
AntiqueOlv Bd	ITC AvantGarde Gothic Demi Oblique
	Bodoni Roman
CG Omega	Bodoni Italic
CG Omega It	Bodoni Bold
CG Omega Bd	Bodoni Bold Italic
CG Omega BdIt	Bodoni Poster
	Bodoni Poster Compressed
Garamond Antiqua	ITC Bookman Light
Garamond Krsv	ITC Bookman Light Italic
Garamond Hlb	ITC Bookman Demi
Garamond KrsvHlb	ITC Bookman Demi Italic
	Carta
Courier	Chicago
Courier It	Clarendon Roman
Courier Bd	Clarendon Bold

Courier BdlT	Clarendon Light
	Cooper Black
LetterGothic	Cooper Black Italic
LetterGothic It	Cooper Gothic 32BC
LetterGothic Bd	Cooper Gothic 33BC
	Coronet
Albertus Md	Courier
Albertus XBd	Courier Oblique
	Courier Bold
Clarendon Cd	Courier Bold Oblique
	Eurostile Medium
Coronet	Eurostile Bold
	Eurostile Extended No. 2
Marigold	Eurostile Bold Extended No. 2
	Geneva
Arial	Gill Sans
Arial It	Gill Sans Italic
Arial Bd	Gill Sans Bold
Arial BdlT	Gill Sans Bold Italic
	Gill Sans Light
TimesNew	Gill Sans Light Italic
TimesNew It	Gill Sans Extra Bold
TimesNew Bd	Gill Sans Condensed
TimesNew BdlT	Gill Sans Condensed Bold
	Goudy Oldstyle
Symbol	Goudy Oldstyle Italic
	Goudy Bold
Wingdings	Goudy Bold Italic
	Goudy Extra Bold
Line Printer	Helvetica
	Helvetica Oblique
Times Roman	Helvetica Bold
Times It	Helvetica Bold Oblique
Times Bd	Helvetica Narrow
Times BdlT	Helvetica Narrow Oblique
	Helvetica Narrow Bold
Helvetica	Helvetica Narrow Bold Oblique
Helvetica Ob	Helvetica Condensed
Helvetica Bd	Helvetica Condensed Oblique
Helvetica BdOb	Helvetica Condensed Bold
	Helvetica Condensed Bold Oblique
CourierPS	Hoefler Text



CourierPS Ob	Hoefler Text Italic
CourierPS Bd	Hoefler Text Black
CourierPS BdOb	Hoefler Text Black Italic
	Hoefler Ornaments
SymbolPS	Joanna
	Joanna Italic
Palatino Roman	Joanna Bold
Palatino It	Joanna Bold Italic
Palatino Bd	Letter Gothic
Palatino BdIt	Letter Gothic Slanted
	Letter Gothic Bold
ITCBookman Lt	Letter Gothic Bold Slanted
ITCBookman LtIt	ITC Lubalin Graph Book
ITCBookmanDm	ITC Lubalin Graph Book Oblique
ITCBookmanDm It	ITC Lubalin Graph Demi
	ITC Lubalin Graph Demi Oblique
HelveticaNr	Marigold
HelveticaNr Ob	Monaco
HelveticaNr Bd	ITC Mona Lisa Recut
HelveticaNr BdOb	New Century Schoolbook Roman
	New Century Schoolbook Italic
N C Schbk Roman	New Century Schoolbook Bold
N C Schbk It	New Century Schoolbook Bold Italic
N C Schbk Bd	NewYork
N C Schbk BdIt	Optima Roman
	Optima Italic
ITC A G Go Bk	Optima Bold
ITC A G Go BkOb	Optima Bold Italic
ITC A G Go Dm	Oxford
ITC A G Go DmOb	Palatino Roman
	Palatino Italic
ZapfC MdlIt	Palatino Bold
	Palatino Bold Italic
ZapfDingbats	Stempel Garamond Roman
	Stempel Garamond Italic
	Stempel Garamond Bold
	Stempel Garamond Bold Italic
	Symbol
	Tekton Regular
	Times Roman
	Times Italic
	Times Bold

	Times Bold Italic
	Times New Roman
	Times New Roman Italic
	Times New Roman Bold
	Times New Roman Bold Italic
	Univers 45 Light
	Univers 45 Light Oblique
	Univers 55
	Univers 55 Oblique
	Univers 65 Bold
	Univers 65 Bold Oblique
	Univers 57 Condensed
	Univers 57 Condensed Oblique
	Univers 67 Condensed Bold
	Univers 67 Condensed Bold Oblique
	Univers 53 Extended
	Univers 53 Extended Oblique
	Univers 63 Extended Bold
	Univers 63 Extended Bold Oblique
	Wingdings
	ITC Zapf Chancery Medium Italic
	ITC Zapf Dingbats

## Symbol Sets

A symbol set is the collection of alphabetic and numeric characters, punctuation, and special characters available in the font you select. Symbol sets support the requirements for different languages or specific applications, such as math symbols used for scientific text.

In PCL 5/PCL 6, a symbol set also defines which character will print for each key on the keyboard (or more specifically, for each *code point*). Some applications require different characters at some code points. To support multiple applications and languages, your printer has 36 symbol sets for the resident PCL 5/PCL 6 fonts.

## Symbol Sets for PCL 5/PCL 6

Not all font names support all of the symbol sets listed.

Roman 8 (Default)	ISO 8859-1 Latin 1	ISO 8859-2 Latin 2
ISO 8859-9 Latin 5	ISO 8859-10 Latin 6	PC-8
PC-8 DN	PC-775 Baltic	PC-850 Multilingual
PC-852 Latin 2	PC-1004 OS/2	PC Turkish
Windows 3.1 Latin 1	Windows 3.1 Latin 2	Windows 3.1 Latin 5
DeskTop	PS Text	MC Text
Microsoft Publishing	Math 8	PS Math
Pi Font	Legal	ISO 4 United Kingdom

ISO 6 ASCII	ISO 11 Swedish:names	ISO 15 Italian
ISO 17 Spanish	ISO 21 German	ISO 60 Norwegian v1
ISO 69 French	Windows 3.0 Latin 1	Windows Baltic
Symbol	Wingdings	ITC ZapfDingbats MS

---

[Back to Contents Page](#)

# Understanding Printer Messages

The printer operator panel displays messages describing the current state of the printer and indicates possible printer problems you must resolve. This topic provides a list of all printer messages, explains what they mean, and tells you how to clear the messages.

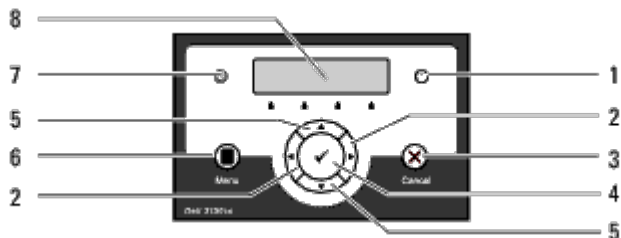

1	Error indicator	5	▼ ▲ buttons
2	◀ ▶ buttons	6	Menu button
3	Cancel button	7	Ready indicator
4	✓ (Set) button	8	LCD Panel

Message	What this message means	What you can do
<p><b>(The first and second lines are displayed together. The third and fourth lines blink every second.)</b></p>		
<p><i>NNN-NNN</i></p> <p>Restart Printer</p> <p>Contact Support</p> <p>IfMessageReturns</p>	<p>Error <i>NNN-NNN</i> relates to printer problems.</p>	<p>Turn off the printer, and then on. If this does not solve the problem, contact Dell.</p> <p>See <a href="#">"Contacting Dell"</a>.</p>
<p><i>NNN-NNN</i></p> <p>Restart Printer</p> <p>Reseat Fuser</p> <p>Contact Support</p>	<p>The outer levers on both sides of the fuser unit are not securely locked.</p> <p>Error <i>NNN-NNN</i> relates to printer problems.</p>	<p>Confirm that the outer levers on both sides of the fuser unit are securely locked. If this does not solve the problem, contact Dell.</p> <p>See <a href="#">"Contacting Dell"</a>.</p>
<p>016-316</p> <p>Restart Printer</p> <p>Reseat Memory</p> <p>Contact Support</p>	<p>The printer detected an unsupported additional memory module in the memory slot.</p>	<p>Remove the additional memory module. If this does not solve the problem, contact Dell.</p> <p>See <a href="#">"Contacting Dell"</a>.</p>
<p>016-318</p> <p>Restart Printer</p> <p>Reseat Memory</p> <p>Contact Support</p>	<p>The additional memory module is not fully inserted into the slot.</p>	<p>Remove the additional memory module from the slot, and then reattach it firmly. If this does not solve the problem, contact Dell.</p> <p>See <a href="#">"Contacting Dell"</a>.</p>
<p>016-340</p> <p>Restart Printer</p> <p>Contact Support</p> <p>IfMessageReturns</p>	<p>A communication error occurred in the network protocol adapter.</p>	<p>Turn the printer off and then on. If this does not solve the problem, contact Dell.</p> <p>See <a href="#">"Contacting Dell"</a>.</p>

016-338 Restart Printer Reseat Wireless Contact Support	An error occurred in the wireless printer adapter.	Turn the printer off and then on. Ensure the following:  The wireless printer adapter is securely inserted into the slot on the controller card.  Unauthorized USB devices are not used.  If this does not solve the problem, contact Dell.  See <a href="#">"Contacting Dell"</a> .
016-365 Restart Printer Reseat NPA Contact Support	A communication card error occurred between the network protocol adapter and control card.	Turn off the printer to re-install the network protocol adapter, and then turn the printer back on again. If this does not solve the problem, contact Dell.  See <a href="#">"Contacting Dell"</a> .
<i>NNN-NNN</i> Restart Printer Reseat <i>XXX</i> Contact Support	<i>XXX</i> is not fully inserted.  Error <i>NNN-NNN</i> relates to printer problems.	Confirm that the unit is securely inserted. If this does not solve the problem, contact Dell.  See <a href="#">"Contacting Dell"</a> .
Paper Jam 077-901 Open Front Cover Remove Paper	The printer detects a paper jam.  <i>XXX</i> and <i>YYY</i> indicates a position that you open.  Error <i>NNN-NNN</i> relates to printer problems.	Clear the paper path.  See <a href="#">"Clearing Jams"</a>
Paper Jam 077-907 Open Front Cover & Belt Unit Remove Paper		
Paper Jam <i>NNN-NNN</i> Open <i>XXX</i> Open <i>YYY</i>		
Paper Jam 075-100 Check MPF Remove Paper Open & close Front Cover	The printer detects a paper jam in the multipurpose feeder (MPF).	Check the MPF and clear the paper path.  See <a href="#">"Clearing Jams"</a>
Paper Jam <i>NNN-NNN</i> Open <i>XXX</i> Remove Paper Open & close Front Cover	The printer detects a paper jam.  <i>XXX</i> indicates a tray that you open.  Error <i>NNN-NNN</i> relates to printer problems.	Pull out the specified tray and clear the paper path.  See <a href="#">"Clearing Jams"</a>
Insert PrintCart <i>NNN-NNN</i>	The specified print cartridge is either missing or not fully inserted into the printer.  <i>XXX</i> is one of the following:  Black	Reinsert the specified print cartridge.

Insert XXX Cartridge	Cyan Yellow Magenta Error <i>NNN-NNN</i> relates to printer problems.	See " <a href="#">Replacing Print Cartridges</a> "
Replace Cart. <i>NNN-NNN</i> Replace XXX Cartridge	The print cartridge is low on toner. XXX is one of the following: Black Cyan Yellow Magenta Error <i>NNN-NNN</i> relates to printer problems.	Remove the specified print cartridge and install a new one.  If you do not replace the print cartridge, print quality problems may occur. Order a new print cartridge at the website ( <a href="http://www.dell.com/supplies">www.dell.com/supplies</a> or <a href="http://www.euro.dell.com/supplies">www.euro.dell.com/supplies</a> ).  See " <a href="#">Replacing Print Cartridges</a> "
<i>Error X Cart.</i> <i>093-NNN</i> <i>Remove Tape from X Cart</i>	The density of the print cartridge is not enough. X is one of the following: Y (yellow) C (cyan) M (magenta) K (black)	Confirm that the toner seal is removed from the specified print cartridge and the cartridge is installed correctly. If this does not solve the problem, contact Dell.  See " <a href="#">Replacing Print Cartridges</a> " See " <a href="#">Contacting Dell</a> ".
<i>Error X Cart.</i> <i>093-NNN</i> <i>Remove Sheet from X Cart</i>	The density of the print cartridge is not enough. X is one of the following: Y (yellow) C (cyan) M (magenta) K (black)	Confirm that the drum protect cover is removed from the specified print cartridge and the cartridge is installed correctly. If this does not solve the problem, contact Dell.  See " <a href="#">Replacing Print Cartridges</a> " See " <a href="#">Contacting Dell</a> ".
<i>Belt Unit</i> <i>094-911</i> <i>Replace Belt</i> <i>Contact Support</i>	The belt unit needs to be replaced now.	Remove the belt unit and install a new one.  Order a new belt unit at the website ( <a href="http://www.dell.com/supplies">www.dell.com/supplies</a> or <a href="http://www.euro.dell.com/supplies">www.euro.dell.com/supplies</a> ).  See " <a href="#">Replacing the Belt Unit</a> "
<i>CRUM ID</i> <i>009-NNN</i> <i>Reseat XXX</i>	An unsupported unit is installed. XXX indicates a unit that you replace.	Remove the unsupported unit and install a supported one.  See " <a href="#">Maintaining Your Printer</a> "
Close FrontCover 077-300 Front Cover Is Open	Printer cover is open.	Close the specified cover.
Load XXX <i>NNN-NNN</i> Load YYY	Incorrect paper size is loaded in the specified tray.  XXX indicates the number of the tray or multipurpose feeder.  YYY indicates a paper size.	Load the specified paper in the specified trays.  See " <a href="#">Loading Print Media in the Standard and Optional Trays</a> "

yyy	yyy indicates paper quality. Error <i>NNN-NNN</i> relates to printer problems.	
Out of Memory 016-700 Job too Large Press ✓	The printer memory is full and cannot continue processing the current print job.	Press ✓ (Set) button to clear the message, cancel the current print job, and conduct the next print job, if any. Press <b>Cancel</b> button to cancel the print job. Press <b>Menu</b> button to open <i>Stored Print</i> and delete the holding job. To avoid this error in the future, do the following: Delete unnecessary fonts, macros, and other data in printer memory. Install additional printer memory. See " <a href="#">Printing Held and Proof Print Jobs</a> "
Disk Full 016-980 Job too Large Press ✓	RAM disk memory or hard disk is full and cannot continue processing the current print job.	Press ✓ (Set) button to clear the message, cancel the current print job, and conduct the next print job, if any. Press <b>Cancel</b> button to cancel the print job. Press <b>Menu</b> button to open <i>Stored Print</i> and delete the current job. To avoid this error in the future, do the following: Reduce the number of print pages such as splitting the print data. Increase free memory space by deleting unnecessary data in the RAM disk or hard disk. See " <a href="#">Printing Held and Proof Print Jobs</a> "
PDL Request 016-720 Data Violation Press ✓	Error relating to PDL emulation problems occurs.	Press ✓ (Set) button to clear the message, cancel the current print job, and conduct the next print job, if any. Press <b>Cancel</b> button to cancel the print job.
Invalid Job 016-799 Data Violation Press ✓	When the configuration of the printer on the printer driver does not conform to the printer you are using, this message appears.	Press <b>Cancel</b> button to cancel the print job. Press ✓ (Set) button to clear the message, cancel the current print job, and conduct the next print job, if any. Ensure that the printer configuration on the printer driver conforms to the printer you are using.
Ready to Print 193-700 Non-DELL Toner Installed	The printer is in the custom print cartridge mode.	Though some of the print cartridges reach the end of their lives, you can continue printing.
Over Heat 042-700 Cooling down Please Wait...	Since it is abnormally hot inside the printer, printing is paused.	Wait for a while with the printer on until the error disappears.
Ready to Print 142-700		

Over Heat

Turned Halfmode

Since it is abnormally hot inside the printer, the print speed decreases.

Do not start another print job until the warning disappears.

---

[Back to Contents Page](#)



## Clearing Jams

- [Avoiding Jams](#)
- [Identifying the Location of Paper Jams](#)
- [Removing Print Jams From the MPF](#)
- [Removing Print Jams From the Standard Tray](#)
- [Removing Print Jams From the Fuser](#)
- [Removing Print Jams From the Optional Duplexer](#)
- [Removing Print Jams From the Optional Feeder](#)

Careful selection of appropriate print media and proper loading allow you to avoid most jams. See "[Print Media Guidelines](#)" for more information.

 **NOTE:** It is recommended that you try a sample first before buying large quantities of any print media.

---

## Avoiding Jams

- Use only recommended print media. See "[Print Media Guidelines](#)" for more information.
  - See "[Loading Print Media in the Standard and Optional Trays](#)" and "[Loading the MPF](#)" to load printer media properly.
  - Do not overload the print media sources. Ensure the stack print media height does not exceed the maximum height indicated by the load line labels in the trays.
  - Do not load wrinkled, creased, damp, or curled print media.
  - Flex, fan, and straighten print media before you load it. If a jam occurs with print media, try feeding one sheet at a time through the multipurpose feeder (MPF).
  - Do not use print media that you have cut or trimmed yourself.
  - Do not mix print media sizes, weights, or types in the same print media source.
  - Ensure that the recommended print side is face up when you insert the print media. Also, the recommended print side should be face down when using the MPF.
  - Keep print media stored in an acceptable environment. For more information, see "[Storing Print Media](#)".
  - Do not remove the feeding tray during a print job.
  - Push all trays in firmly after loading them.
  - Ensure that all cables that connect to the printer are correctly attached.
  - Overtightening the guides may cause jams.
  - Wipe the feeder rollers in the trays or MPF with a cloth that is slightly dampened with water if jams caused by misfeeding paper occur frequently.
- 

## Identifying the Location of Paper Jams

The following illustration shows where paper jams may occur along the print media path.

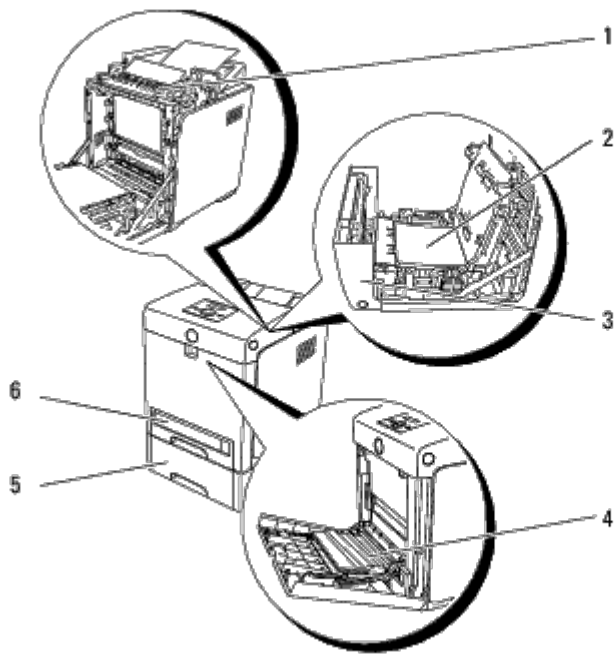

**⚠ CAUTION:** Do not attempt to clear any jams using tools or instruments. This may permanently damage the printer.

1	Fuser
2	Duplexer (optional)
3	Front Cover
4	MPF
5	550 Sheet Feeder (optional)
6	Tray 1

## Removing Print Jams From the MPF

**👉 NOTICE:** To protect the drums of the print cartridges against bright light, close the front cover within five minutes. If the front cover remains open for more than five minutes, print quality may deteriorate.

**🔧 NOTE:** To resolve the error displayed on the operator panel, you must clear all print media from the print media path.

1. Pull the jammed paper out of the MPF. If no jammed paper can be found or it is hard to remove the paper, close the MPF and go to the next step to remove the jammed paper from the inside of the printer.

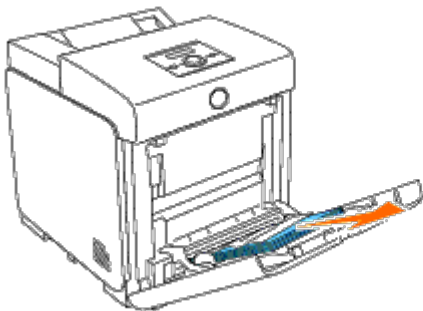

2. Remove the 250-sheet tray from the printer, and then pull out the jammed paper remaining inside the printer. If no jammed paper can be found or it is hard to remove the paper, go to the next step to remove the jammed paper from the inside of the printer.

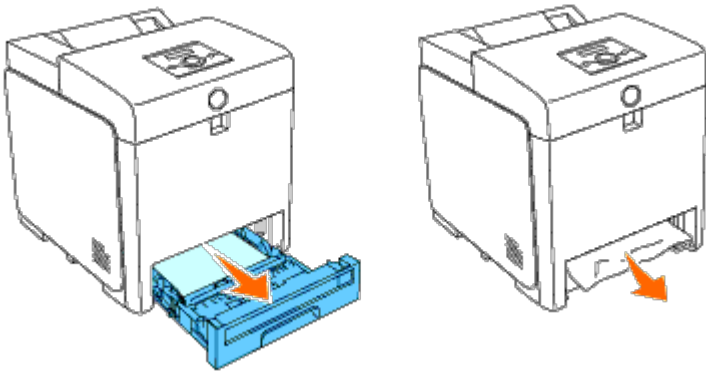

3. Open the front cover by pushing the button (right side) and remove the jammed paper. Then, confirm that there are no scraps of paper remaining inside the printer.

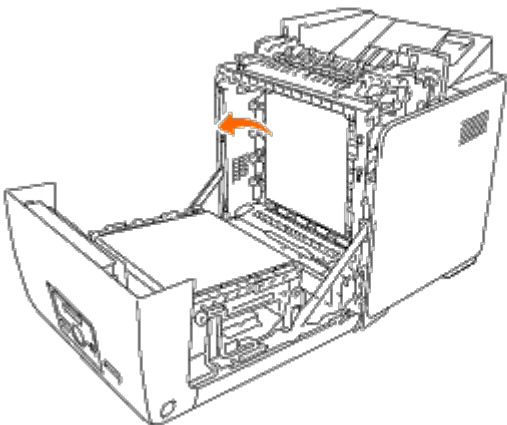
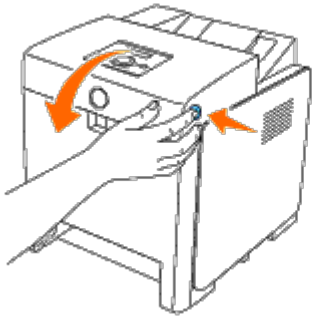

4. Close the front cover.

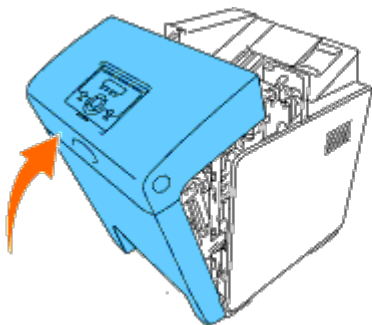

5. Insert the tray back into the printer, and push until it stops.

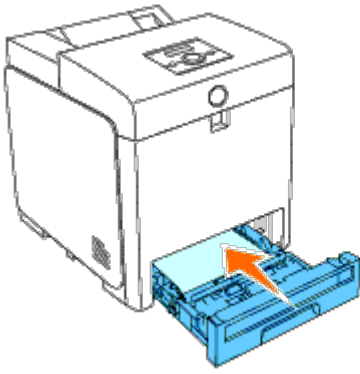

6. Open and close the front cover.

---

## Removing Print Jams From the Standard Tray

 **NOTICE:** To protect the drums of the print cartridges against bright light, close the front cover within five minutes. If the front cover remains open for more than five minutes, print quality may deteriorate.

 **NOTE:** To resolve the error displayed on the operator panel, you must clear all print media from the print media path.

1. Pull the Tray 1 out of the printer until it stops. Hold the tray with both hands, lift the front slightly, and remove it from the printer.

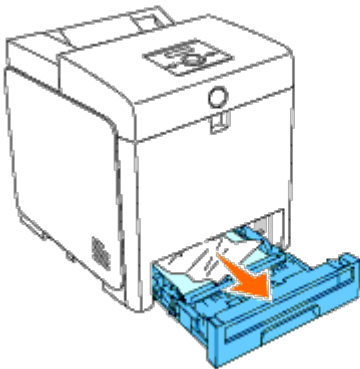

2. Remove all the jammed and/or creased paper from the Tray 1.

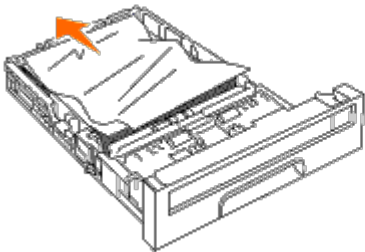

3. Pull the jammed paper out carefully to avoid tearing it. If it is still hard to remove the paper, go to the next step to remove the jammed paper from the inside of the printer.

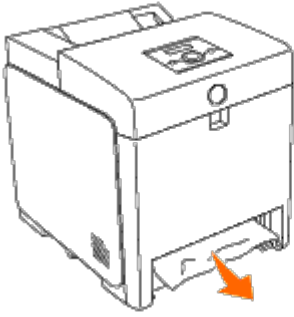

4. Open the front cover by pushing the button (right side) and remove the jammed paper. Then, confirm that there are no scraps of paper remaining inside the printer.

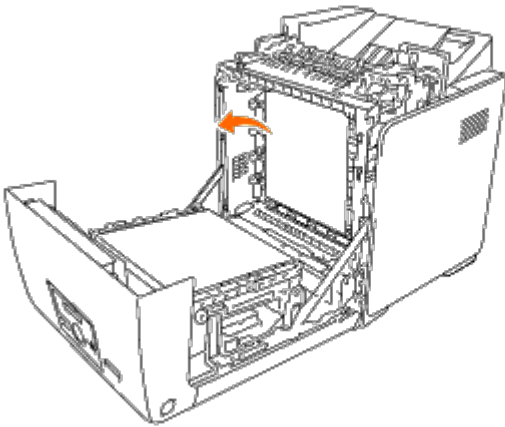
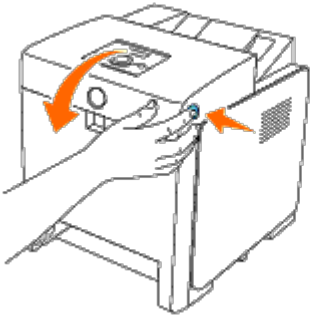

5. Close the front cover.

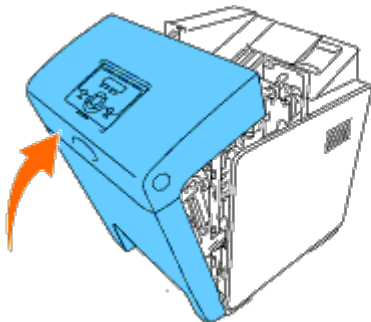

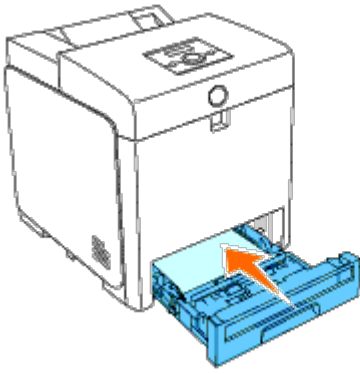

6. Insert the Tray 1 into the printer, and push until it stops.



**CAUTION:** Do not use excessive force on the tray. Doing so could damage the tray or the inside of the printer.

## Removing Print Jams From the Fuser

-  **NOTICE:** Ensure nothing touches or scratches the surface (black-colored film) of the belt unit. Scratches, dirt, or oil from your hands on the film of the belt unit may reduce print quality.
-  **NOTE:** To protect the drums of the print cartridges against bright light, close the front cover within five minutes. If the front cover remains open for more than five minutes, print quality may deteriorate.
-  **NOTE:** To resolve the error displayed on the operator panel, you must clear all print media from the print media path.

1. Turn off the printer and wait for 30 minutes.
2. Push the button (right side) and open the front cover.

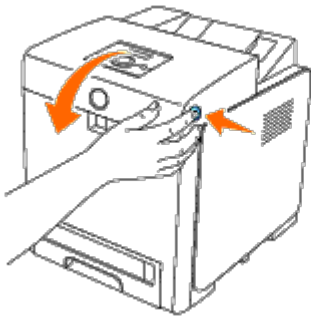

3. Lift the levers at both ends of the fuser, and remove the jammed paper. If any jammed paper cannot be found, go to the next step.

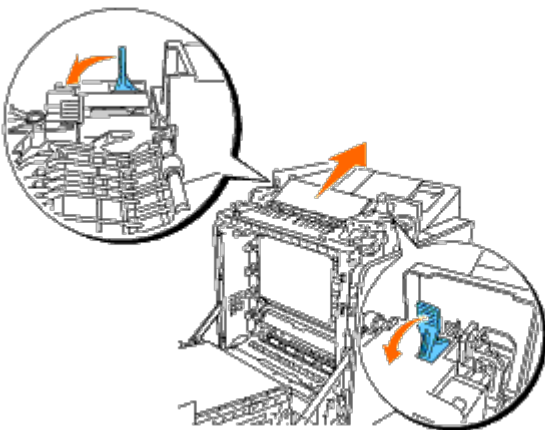

The fuser is hot. Do not touch it, doing so may cause burns.

4. Open the cover of the fuser and remove the jammed paper.

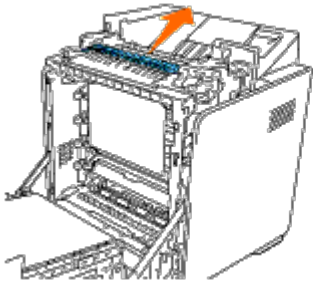

5. Close the cover of the fuser and press down the levers at both ends of the fuser.

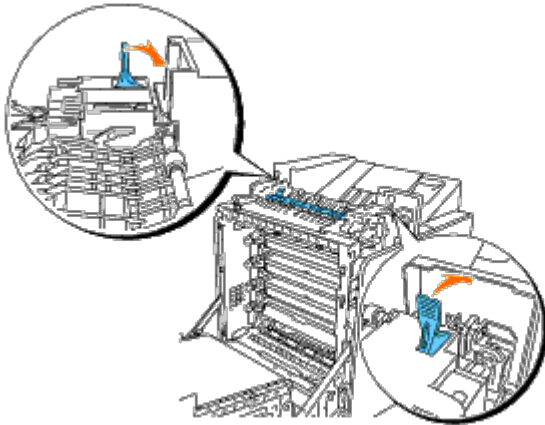

6. Confirm that there are no scraps of paper remaining inside the printer, and then close the front cover.

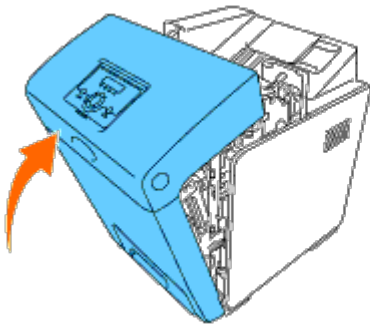

---

## Removing Print Jams From the Optional Duplexer

- ➡ **NOTICE:** Ensure nothing touches or scratches the surface (black-colored film) of the belt unit. Scratches, dirt, or oil from your hands on the film of the belt unit may reduce print quality.
- ➡ **NOTICE:** To protect the drums of the print cartridges against bright light, close the front cover within five minutes. If the front cover remains open for more than five minutes, print quality may deteriorate.
- 🔧 **NOTE:** To resolve the error displayed on the operator panel, you must clear all print media from the print media path.

1. Push the button (right side) and open the front cover.

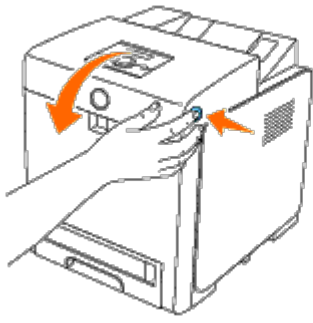

2. Pull out the jammed paper from the duplexer. If jammed paper cannot be found, go to the next step.

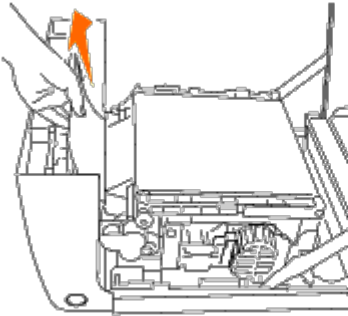

3. Pull up on the belt release levers and rotate the belt unit up as shown in the illustration.

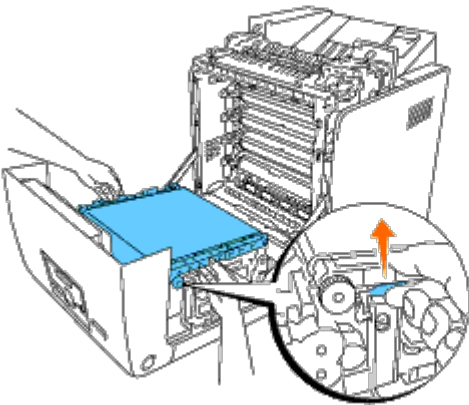

4. Remove the jammed paper and close the belt unit.

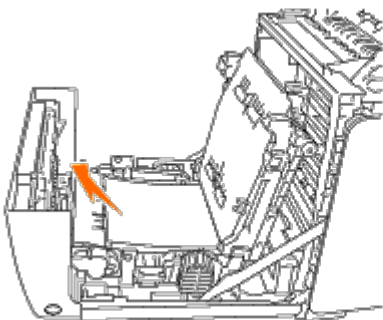

5. Close the front cover.



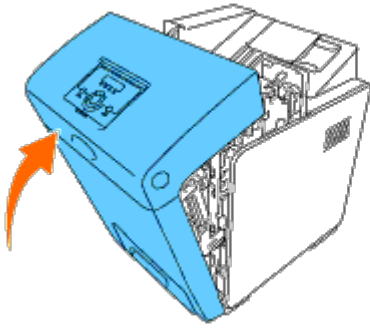

## Removing Print Jams From the Optional Feeder

➡ **NOTICE:** To protect the drums of the print cartridges against bright light, close the front cover within five minutes. If the front cover remains open for more than five minutes, print quality may deteriorate.

🔧 **NOTE:** To resolve the error displayed on the operator panel, you must clear all print media from the print media path.

1. Pull the tray out of the printer until it stops. Hold the tray with both hands, lift the front slightly, and remove it from the printer.

🔧 **NOTE:** Paper in the 550 sheet feeder feeds to the printer from the front of the 250-sheet tray, therefore paper jammed in the 250-sheet tray can block the optional tray module in the printer, preventing you from opening them. Look for the jammed paper sequentially, starting with the optional 550 sheet feeder.

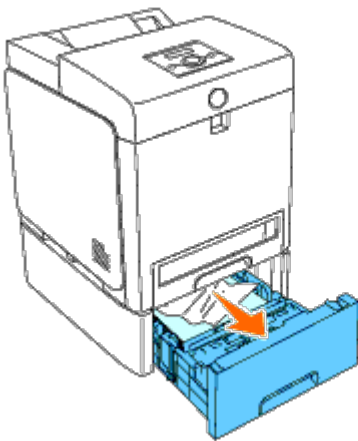

2. Remove all jammed and/or creased paper from the tray.

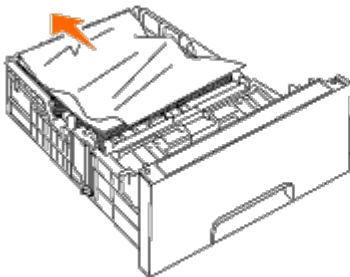

3. Pull the jammed paper out carefully to avoid tearing it. If it is still hard to remove the paper, go to the next step to remove the jammed paper from the inside of the printer.

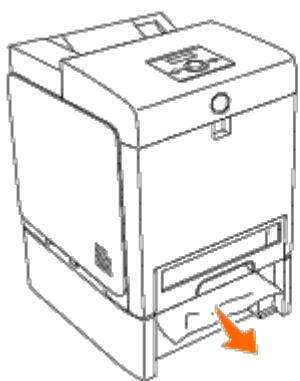

4. Open the front cover by pushing the button (right side) and remove the jammed paper. Then, confirm that there are no scraps of paper remaining inside the printer.

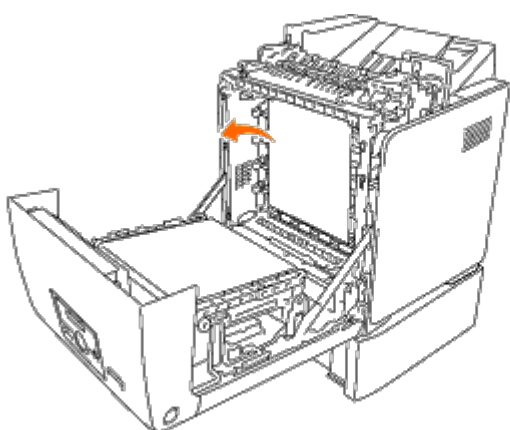
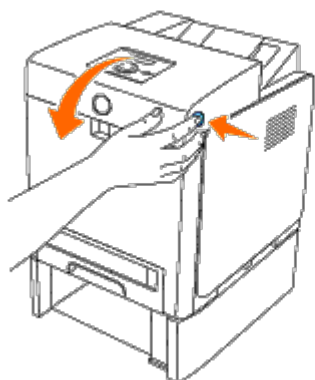

5. Close the front cover.

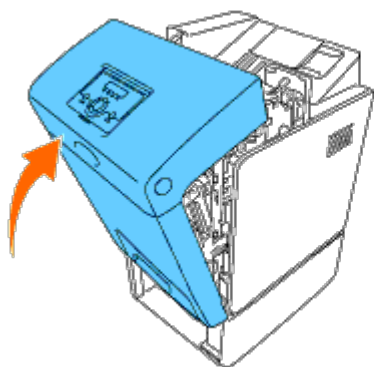

 **NOTE:** If the paper jam message is not cleared after closing the front cover, pull out the 250-sheet tray from the printer and remove the jammed paper.

6. Insert the tray back into the printer, and push until it stops.

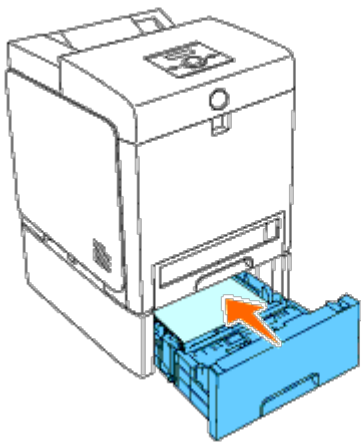

**⚠ CAUTION:** Do not use excessive force on the tray. Doing so could damage the tray or the inside of the printer.

---

[Back to Contents Page](#)

# Troubleshooting Guide

- [Basic Printer Problems](#)
- [Display Problems](#)
- [Printing Problems](#)
- [Print Quality Problems](#)
- [Jam/Alignment Problems](#)
- [Option Problem](#)
- [Other Problems](#)
- [Contacting Service](#)

---

## Basic Printer Problems

Some printer problems can be easy to resolve. If a problem occurs with your printer, check each of the following:

- The power cable is plugged into the printer and a properly grounded electrical outlet.
- The printer's power is on.
- The electrical outlet is not turned off at any switch or breaker.
- Other electrical equipment plugged into the outlet is working.
- All options are properly installed.
- The wireless printer adapter is not installed if you use the network protocol adapter with the wired network.

If you have checked all of the above and still have a problem, turn off the printer, wait for 10 seconds, and then turn on the printer. This often fixes the problem.

---

## Display Problems

Problem	Action
After the printer is turned on, the display on the operator panel is blank, keeps showing <code>Please wait...</code> , or the back light is not lit.	<ul style="list-style-type: none"><li>• Turn off the printer, wait for 10 seconds, and turn on the printer.</li><li>• Self Test Message appears on the operator panel. When the test is completed, <code>Ready to Print</code> is displayed.</li></ul>
Menu settings changed from the operator panel have no effect.	<p>Settings in the software program, the printer driver, or the printer utilities are overriding the settings made on the operator panel.</p> <ul style="list-style-type: none"><li>• Change the menu settings from the printer driver, the printer utilities, or the software program instead of the operator panel.</li></ul>

---

## Printing Problems

Problem	Action
---------	--------

Job did not print or incorrect characters printed.	Ensure <code>Ready to Print</code> appears on the operator panel before you send a job to print. Press <b>Menu</b> button to return to <code>Ready to Print</code> .
	Ensure print media is loaded in the printer. Press <b>Menu</b> button to return to <code>Ready to Print</code> .
	Verify the printer is using the correct page description language (PDL).
	Verify that you are using the correct printer driver.
	Ensure you are using the correct Ethernet, USB, Parallel cable, or wireless printer adapter and that it is securely connected to the printer.
	Verify that the correct print media size is selected.
	If using a print spooler, verify that the spooler has not stalled.
	Check the printer's interface from the <code>Admin Menu</code> .  Determine the host interface you are using. Print a panel settings page to verify that the current interface settings are correct. Refer to " <a href="#">Printing a Panel Settings Page</a> " for details on how to print a panel settings page.
Print media misfeeds or multiple feeds occur.	Ensure the print media you are using meets the specifications for your printer. See " <a href="#">Supported Paper Types</a> " for more information.
	Flex print media before loading it in any of the sources.
	Ensure the print media is loaded correctly.
	Ensure the width and length guides on the print media sources are adjusted correctly.
	Ensure the trays are securely inserted.
	Do not overfill the print media sources.
	Do not force print media into the multipurpose feeder (MPF) when you load it; otherwise, it may skew or buckle.
	Remove any curled print media from sources.
	Load the recommended print side correctly for the type of print media you are using. See " <a href="#">Loading Print Media in the Standard and Optional Trays</a> " for more information.
	Turn the print media over or around and try printing again to see if feeding improves.
	Do not mix print media types.
	Do not mix reams of print media.
	Remove the top and bottom curled sheets of a ream before loading the print media.
Load a print media source only when it is empty.	
Wipe the separator rollers in the trays or MPF with a cloth that slightly dampened with water.	
Envelope misfeeds or multiple feeds occur.	Reduce the number of envelopes in the stack.
Page breaks in unexpected places.	Increase the setting for <b>Time-Out</b> in the <b>Printer Settings</b> menu in the <b>Dell Printer Configuration Web Tool</b> .
Job prints from the wrong source or on the wrong print media.	Check the <code>Paper Types</code> in the <code>Tray Settings</code> menu on the printer operator panel and in the printer driver.
Print media does not stack neatly in the output bin.	Turn the print media stack over in the tray or MPF.
Printer does not duplex pages.	Ensure <code>2 Sided</code> is selected in both the <code>PCL (Printer Control Language)</code> menu on the printer operator panel and in the printer driver.
	Ensure you have enough print memory installed.
Paper is curled in the trays.	Load the paper into the MPF.

# Print Quality Problems

 **NOTE:** Some of the following procedures that use the Tool Box can also be performed using the operator panel or Dell Printer Configuration Web Tool. For information on how to use the operator panel and Dell Configuration Web Tool, see ["Understanding the Printer Menus"](#) and ["Dell Printer Configuration Web Tool"](#).

## The entire output is too light.



Action	Yes	No
<p>1 The print cartridges may be low or need to be replaced. Confirm the amount of toner in each print cartridge.</p> <ol style="list-style-type: none"> <li>1. Check the toner level in the <b>Status</b> tab in the Status Monitor.</li> <li>2. Replace the print cartridges as necessary.</li> </ol> <p>Is the problem recovered?</p>	The task is complete.	Go to action 2.
<p>2 If the user is using non-Dell brand print cartridges, disable the <b>Non-Dell Toner</b> option.</p> <ol style="list-style-type: none"> <li>1. Launch the Tool Box, and click <b>Non-Dell Toner</b> on the <b>Printer Maintenance</b> tab.</li> <li>2. Ensure that the <b>On</b> check box is not selected.</li> </ol> <p>Is the problem recovered?</p>	The task is complete.	Go to action 3.
<p>3 Disable the <b>Toner Saving Mode</b> in the printer driver.</p> <ol style="list-style-type: none"> <li>1. On the <b>Advanced</b> tab, ensure that the <b>Toner Saving Mode</b> check box is not selected.</li> </ol> <p>Is the problem recovered?</p>	The task is complete.	Go to action 4.
<p>4 The print media surface may be uneven. Try changing the <b>Paper Type</b> setting in the printer driver. For example, change the plain paper to thick.</p> <ol style="list-style-type: none"> <li>1. On the <b>Paper/Output</b> tab, change the <b>Paper Type</b> setting.</li> </ol> <p>Is the problem recovered?</p>	The task is complete.	Go to action 5.
<p>5 Verify that the correct print media is being used. See <a href="#">"Supported Paper Sizes"</a>. If not, use the print media recommended for the printer.</p> <p>Is the problem recovered?</p>	The task is complete.	Go to action 6.
<p>6 Ensure that four orange ribbons and four yellow ribbons are correctly removed from the print cartridge. See <a href="#">"Replacing Print Cartridges"</a>. If not, remove the ribbons.</p> <p>Is the problem recovered?</p>	The task is complete.	Go to action 7.
<p>7 Replace the print cartridge if you have a spare.</p> <ol style="list-style-type: none"> <li>1. Replace the print cartridge. See <a href="#">"Installing the Print Cartridges"</a> and <a href="#">"Replacing Print Cartridges"</a>.</li> <li>2. After you replace the print cartridge, click <b>Chart Print</b> on the <b>Diagnosis</b> tab.</li> <li>3. Click the <b>4 Colors Configuration Chart</b> button.</li> </ol> <p>The 4 Colors Configuration Chart is printed.</p> <p>Is the problem recovered?</p>	The task is complete.	Contact Dell.

## Toner smears or print comes off.



Action		Yes	No
1	<p>The print media surface may be uneven. Try changing the <b>Paper Type</b> setting in the printer driver. For example, change the plain paper to thick.</p> <p>1. On the <b>Paper/Output</b> tab, change the <b>Paper Type</b> setting.</p> <p>Is the problem recovered?</p>	The task is complete.	Go to action 2.
2	<p>Verify that the correct print media is being used. See "<a href="#">Supported Paper Sizes</a>". If not, use the print media recommended for the printer.</p> <p>Is the problem recovered?</p>	The task is complete.	Go to action 3.
3	<p>Replace the fuser if you have a spare.</p> <p>1. Replace the fuser. See "<a href="#">Replacing the Fuser</a>".</p> <p>2. After you replace the fuser, test print your document again.</p> <p>Is the problem recovered?</p>	The task is complete.	Contact Dell.

## Random spots/blurred images



Action		Yes	No
1	<p>Ensure that the print cartridges are installed correctly. See "<a href="#">Installing the Print Cartridges</a>".</p> <p>Is the problem recovered?</p>	The task is complete.	Go to action 2.
2	<p>Replace the print cartridge if you have a spare.</p> <p>1. Replace the print cartridge. See "<a href="#">Installing the Print Cartridges</a>" and "<a href="#">Replacing Print Cartridges</a>".</p> <p>2. After you replace the print cartridge, click <b>Chart Print</b> on the <b>Diagnosis</b> tab.</p> <p>3. Click the <b>Pitch Configuration Chart</b> button.</p> <p>The Pitch Configuration Chart is printed.</p> <p>Is the problem recovered?</p>	The task is complete.	Contact Dell.

## The entire output is blank.

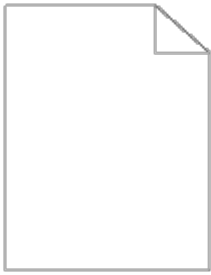

Action	Yes	No
<p>1 The print cartridges may be low or need to be replaced. Confirm the amount of toner in each print cartridge.</p> <ol style="list-style-type: none"> <li>1. Check the toner level in the <b>Status</b> tab in the Status Monitor.</li> <li>2. Replace the print cartridges as necessary.</li> </ol> <p>Is the problem recovered?</p>	The task is complete.	Go to action 2.
<p>2 If the user is using non-Dell brand print cartridges, disable the <b>Non-Dell Toner</b> option.</p> <ol style="list-style-type: none"> <li>1. Launch the Tool Box, and click <b>Non-Dell Toner</b> on the <b>Printer Maintenance</b> tab.</li> <li>2. Ensure that the <b>On</b> check box is not selected.</li> </ol> <p>Is the problem recovered?</p>	The task is complete.	Go to action 3.
<p>3 Disable the <b>Toner Saving Mode</b> in the printer driver.</p> <ol style="list-style-type: none"> <li>1. On the <b>Advanced</b> tab, ensure that the <b>Toner Saving Mode</b> check box is not selected.</li> </ol> <p>Is the problem recovered?</p>	The task is complete.	Go to action 4.
<p>4 The print media surface may be uneven. Try changing the <b>Paper Type</b> setting in the printer driver. For example, change the plain paper to thick.</p> <ol style="list-style-type: none"> <li>1. On the <b>Paper/Output</b> tab, change the <b>Paper Type</b> setting.</li> </ol> <p>Is the problem recovered?</p>	The task is complete.	Go to action 5.
<p>5 Verify that the correct print media is being used. See "<a href="#">Supported Paper Sizes</a>". If not, use the print media recommended for the printer.</p> <p>Is the problem recovered?</p>	The task is complete.	Contact Dell.
<p>6 Ensure that four orange ribbons and four yellow ribbons are correctly removed from the print cartridge. See "<a href="#">Replacing Print Cartridges</a>". If not, remove the ribbons.</p> <p>Is the problem recovered?</p>	The task is complete.	Go to action 7.
<p>7 Replace the print cartridge if you have a spare.</p> <ol style="list-style-type: none"> <li>1. Replace the print cartridge. See "<a href="#">Installing the Print Cartridges</a>" and "<a href="#">Replacing Print Cartridges</a>".</li> <li>2. After you replace the print cartridge, click <b>Chart Print</b> on the <b>Diagnosis</b> tab.</li> <li>3. Click the <b>4 Colors Configuration Chart</b> button.</li> </ol> <p>The 4 Colors Configuration Chart is printed.</p> <p>Is the problem recovered?</p>	The task is complete.	Contact Dell.

## Streaks appear on the output.

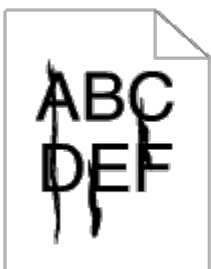



Action		Yes	No
1	<p>The print cartridges may be low or need to be replaced. Confirm the amount of toner in each print cartridge.</p> <ol style="list-style-type: none"> <li>1. Check the toner level in the <b>Status</b> tab in the Status Monitor.</li> <li>2. Replace the print cartridges as necessary.</li> </ol> <p>Is the problem recovered?</p>	The task is complete.	Go to action 2.
2	<p>If the user is using non-Dell brand print cartridges, disable the <b>Non-Dell Toner</b> option.</p> <ol style="list-style-type: none"> <li>1. Launch the Tool Box, and click <b>Non-Dell Toner</b> on the <b>Printer Maintenance</b> tab.</li> <li>2. Ensure that the <b>On</b> check box is not selected.</li> </ol> <p>Is the problem recovered?</p>	The task is complete.	Go to action 3.
3	<p>Replace the print cartridge if you have a spare.</p> <ol style="list-style-type: none"> <li>1. Replace the print cartridge. See <a href="#">"Installing the Print Cartridges"</a> and <a href="#">"Replacing Print Cartridges"</a>.</li> <li>2. After you replace the print cartridge, click <b>Chart Print</b> on the <b>Diagnosis</b> tab.</li> <li>3. Click the <b>Pitch Configuration Chart</b> button.</li> </ol> <p>The Pitch Configuration Chart is printed.</p> <p>Is the problem recovered?</p>	The task is complete.	Contact Dell.

## Part or the entire output is black.

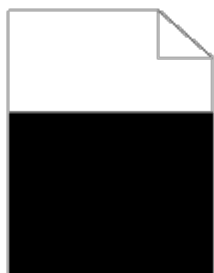

Action		Yes	No
1	<p>Ensure that the print cartridges are installed correctly. See <a href="#">"Installing the Print Cartridges"</a>.</p> <p>Is the problem recovered?</p>	The task is complete.	Go to action 2.
2	<p>Ensure <b>Output Color</b> is set to <b>Color (Auto)</b> in the printer driver.</p> <ol style="list-style-type: none"> <li>1. On the <b>Graphics</b> tab, ensure that the <b>Output Color</b> is set to <b>Color (Auto)</b>.</li> </ol> <p>Is the problem recovered?</p>	The task is complete.	Go to action 3.
3	<p>Replace the print cartridge if you have a spare.</p> <ol style="list-style-type: none"> <li>1. Replace the print cartridge. See <a href="#">"Installing the Print Cartridges"</a> and <a href="#">"Replacing Print Cartridges"</a>.</li> <li>2. After you replace the print cartridge, click <b>Chart Print</b> on the <b>Diagnosis</b> tab.</li> <li>3. Click the <b>4 Colors Configuration Chart</b> button.</li> </ol> <p>The 4 Colors Configuration Chart is printed.</p> <p>Is the problem recovered?</p>	The task is complete.	Contact Dell.

## Pitched color dots



Action	Yes	No
<p>1</p> <p>Locate the cause of the problem using the Pitch Configuration Chart.</p> <ol style="list-style-type: none"> <li>1. Launch the Tool Box, and click <b>Chart Print</b> on the <b>Diagnosis</b> tab.</li> <li>2. Click the <b>Pitch Configuration Chart</b> button.</li> </ol> <p>The Pitch Configuration Chart is printed.</p> <ol style="list-style-type: none"> <li>3. Compare the pitch of the color spots on your output with that on the Pitch Configuration Chart, and locate the cause of the problem.</li> </ol> <p>Is the cause of the problem located?</p>	<p>Proceed to the action corresponding to the location of the problem:</p> <ul style="list-style-type: none"> <li>• Print cartridge- 2</li> <li>• Fuser - 3</li> <li>• Main unit of the printer - contact Dell.</li> </ul>	<p>Contact Dell.</p>
<p>2</p> <p>Replace the print cartridge if you have a spare.</p> <ol style="list-style-type: none"> <li>1. Replace the print cartridge. See <a href="#">"Installing the Print Cartridges"</a> and <a href="#">"Replacing Print Cartridges"</a>.</li> <li>2. After you replace the print cartridge, click <b>Chart Print</b> on the <b>Diagnosis</b> tab.</li> <li>3. Click the <b>Pitch Configuration Chart</b> button.</li> </ol> <p>The Pitch Configuration Chart is printed.</p> <p>Is the problem recovered?</p>	<p>The task is complete.</p>	<p>Contact Dell.</p>
<p>3</p> <p>Replace the fuser if you have a spare.</p> <ol style="list-style-type: none"> <li>1. Replace the fuser. See <a href="#">"Replacing the Fuser"</a>.</li> <li>2. After you replace the print cartridge, click <b>Chart Print</b> on the <b>Diagnosis</b> tab.</li> <li>3. Click the <b>Pitch Configuration Chart</b> button.</li> </ol> <p>The Pitch Configuration Chart is printed.</p> <p>Is the problem recovered?</p>	<p>The task is complete.</p>	<p>Contact Dell.</p>

## Vertical blanks

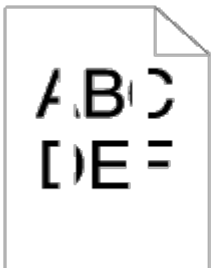

Action	Yes	No
<p>1</p> <p>Ensure the light path is not covered.</p> <ol style="list-style-type: none"> <li>1. Remove the print cartridge, and keep it in the dark place. See <a href="#">"Replacing Print Cartridges"</a>.</li> <li>2. Check the light path, and then remove the shielding.</li> <li>3. Reinstall the print cartridge. See <a href="#">"Installing a New Print Cartridge"</a>.</li> <li>4. Launch the Tool Box, and click <b>Chart Print</b> on the <b>Diagnosis</b> tab.</li> </ol>	<p>The task is complete.</p>	<p>Go to action 2.</p>

	<p>5. Click the <b>Pitch Configuration Chart</b> button.</p> <p>The Pitch Configuration Chart is printed.</p> <p>Is the problem recovered?</p>		
2	<p>Replace the print cartridge if you have a spare.</p> <ol style="list-style-type: none"> <li>1. Replace the print cartridge. See <a href="#">"Installing the Print Cartridges"</a> and <a href="#">"Replacing Print Cartridges"</a>.</li> <li>2. After you replace the print cartridge, click <b>Chart Print</b> on the <b>Diagnosis</b> tab.</li> <li>3. Click the <b>Pitch Configuration Chart</b> button.</li> </ol> <p>The Pitch Configuration Chart is printed.</p> <p>Is the problem recovered?</p>	The task is complete.	Contact Dell.

## Ghosting

Action	Yes	No
<p>1</p> <p>Locate the cause of the problem using the Ghost Configuration Chart.</p> <ol style="list-style-type: none"> <li>1. Launch the Tool Box, and click <b>Chart Print</b> on the <b>Diagnosis</b> tab.</li> <li>2. Click the <b>Ghost Configuration Chart</b> button.</li> </ol> <p>The Ghost Configuration Chart is printed.</p> <p>Is the type of ghosting identified?</p>	<p>Proceed to the action corresponding to the type of ghosting.</p> <p>Positive ghost - 2a</p> <p>Negative ghost - 2b</p>	Contact Dell.
<p>2a</p> <p>Replace the print cartridge if you have a spare.</p> <ol style="list-style-type: none"> <li>1. Replace the print cartridge. See <a href="#">"Installing the Print Cartridges"</a> and <a href="#">"Replacing Print Cartridges"</a>.</li> <li>2. After you replace the print cartridge, click <b>Chart Print</b> on the <b>Diagnosis</b> tab.</li> <li>3. Click the <b>Ghost Configuration Chart</b> button.</li> </ol> <p>The Ghost Configuration Chart is printed.</p> <p>Is the problem recovered?</p>	The task is complete.	Contact Dell.
<p>2b</p> <p>If using non-recommended print media, use the print media recommended for the printer.</p> <p>Is the problem recovered?</p>	The task is complete.	Go to action 2a.

## Bead-Carry-Out (BCO)



Action	Yes	No
<p>1</p> <p>If the printer is installed in a high altitude location, set the altitude of the location.</p> <ol style="list-style-type: none"> <li>1. Launch the Tool Box, and click <b>Adjust Altitude</b> on the <b>Printer Maintenance</b> tab.</li> </ol>	The task is complete.	Go to action 2.

	2. Select the value close to the altitude of the location where the printer is installed. Is them problem recovered?		
2	Replace the print cartridge. See <a href="#">"Installing the Print Cartridges"</a> . Is the problem recovered?	The task is complete.	Contact Dell.

## Jagged characters



Action		Yes	No
1	Set <b>Print Mode</b> to <b>High Quality</b> in the printer driver. 1. On the <b>Graphics</b> tab, select <b>High Quality</b> from <b>Print Mode</b> . Is the problem recovered?	The task is complete.	Go to action 2.
2	Enable <b>Bitmap Text Smoothing</b> in the printer driver. 1. <b>On the Advanced</b> tab, set <b>Bitmap Text Smoothing</b> under <b>Items</b> to <b>On</b> . Is the problem recovered?	The task is complete.	Go to action 3.
3	If using a downloaded font, ensure that the font is recommended for the printer, operating system, and the application being used. Is the problem recovered?	The task is complete.	Contact Dell.

## Banding



Action		Yes	No
1	Locate the cause of the problem using the MQ Chart. 1. Launch the Tool Box, and click <b>Chart Print</b> on the <b>Diagnosis</b> tab. 2. Click the <b>MQ Chart</b> button. The MQ Chart is printed. Is the cause of the problem located?	Proceed to the action corresponding to the location of the problem: <ul style="list-style-type: none"> <li>Print cartridge - 2</li> <li>Fuser - Contact Dell.</li> <li>Main unit of the machine - contact Dell.</li> </ul>	Contact Dell.
	Replace the print cartridge if you have a spare. 1. Replace the print cartridge. See <a href="#">"Installing the Print Cartridges"</a> and <a href="#">"Replacing Print Cartridges"</a> .		

2	<ol style="list-style-type: none"> <li>2. After you replace the print cartridge, click <b>Chart Print</b> on the <b>Diagnosis</b> tab.</li> <li>3. Click the <b>MQ Chart</b> button.</li> </ol> <p style="margin-left: 40px;">The MQ Chart is printed.</p> <p>Is the problem recovered?</p>	The task is complete.	Contact Dell.
---	---------------------------------------------------------------------------------------------------------------------------------------------------------------------------------------------------------------------------------------------------------------------------------------------	-----------------------	---------------

## Creased/stained paper

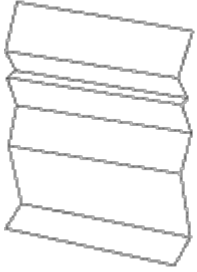

	Action	Yes	No
1	<p>Verify that the correct print media is being used. See "<a href="#">Supported Paper Sizes</a>". If not, use the print media recommended for the printer.</p> <p>Is the problem recovered?</p>	The task is complete.	If printing on an envelope, go to action 2.
2	<p>Condensation inside the printer causes creased paper. Keep the printer turned on and leave it more than one hour to get rid of the condensation. In winter, keep the printer turned on to prevent condensation from forming. In this case, you can reduce power consumption by using the energy-saving mode. If the problems still occur, contact Dell. See "<a href="#">Contacting Dell</a>".</p>	The task is complete.	If printing on an envelope, go to action 3.
3	<p>Replace the fuser if you have a spare.</p> <ol style="list-style-type: none"> <li>1. Replace the fuser. See "<a href="#">Replacing the Fuser</a>".</li> <li>2. After you replace the fuser, test print your document again.</li> </ol> <p>Is the problem recovered?</p>	Contact Dell.	Contact Dell.

## Jam/Alignment Problems

**NOTE:** Some of the following procedures that use the Tool Box can also be performed using the operator panel or Dell Printer Configuration Web Tool. For information on how to use the operator panel and Dell Configuration Web Tool, see "[Understanding the Printer Menus](#)" and "[Dell Printer Configuration Web Tool](#)".

### The top and side margins are incorrect.



Action	Yes	No

1	Ensure that the margins are set correctly on the application being used. Is the problem recovered?	The task is complete.	Contact Dell.
---	-------------------------------------------------------------------------------------------------------	-----------------------	---------------

## The color registration is out of alignment.

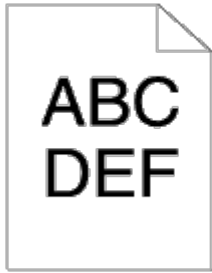

Action		Yes	No
1	<p>Execute auto color registration adjustment.</p> <ol style="list-style-type: none"> <li>1. Launch the Tool Box, and click <b>Registration Adjustment</b> on the <b>Printer Maintenance</b> tab.</li> <li>2. Click <b>Auto Correct</b> under <b>Color Registration Adjustments</b>.</li> </ol> <p>Is the problem recovered?</p>	The task is complete.	Go to action 2.
2a	<p>Replace the print cartridge. See <a href="#">"Installing the Print Cartridges"</a>.</p> <p>Is the problem recovered?</p>	The task is complete.	Contact Dell.
2b	<p>Print the Color Regi Configuration Chart and manually correct the color registration.</p> <ol style="list-style-type: none"> <li>1. On the <b>Registration Adjustment</b> page, click the <b>Color Regi Chart</b> button. The Color Regi Configuration Chart is printed.</li> <li>2. Identify the offset values from the chart and enter them in <b>Enter Number</b>. See <a href="#">"Adjusting Color Registration"</a> for details.</li> <li>3. Click the <b>Apply New Settings</b> button.</li> <li>4. Click the <b>Color Regi Chart</b> button to print the Color Regi Configuration Chart again.</li> </ol> <p>Is the problem recovered?</p>	The task is complete.	Contact Dell.

## Misfeed jam

Action		Yes	No
1	<p>Ensure that the tray 1 is properly inserted.</p> <p>Is the problem recovered?</p>	The task is complete.	<p>Proceed to the action corresponding to the type of the print media being used:</p> <ul style="list-style-type: none"> <li>• Thick - 2a</li> <li>• Thin - 2b</li> <li>• Coated - 2c</li> </ul> <p>If performing duplex printing, go to action 2d.</p> <p>If using paper other than the above or if not performing duplex printing, go to action 2e.</p>
2a	<p>Use Thick paper that is 216 gsm or less.</p> <p>Is the problem recovered?</p>	The task is complete.	Go to action 3a.
2b	<p>Use Thin paper that is 216 gsm or less.</p> <p>Is the problem recovered?</p>	The task is complete.	Go to action 3a.
	<p>Load Coated paper one sheet at a time.</p>		

2c	Is the problem recovered?	The task is complete.	Go to action 3b.
2d	Ensure that the print media is not curled. Is the problem recovered?	The task is complete.	Go to action 3a.
2e	Is the print media damp?	Go to action 3c.	Go to action 3a.
3a	Fan the print media. Is the problem recovered?	The task is complete.	Go to action 3b.
3b	Wipe the retard roller in the tray 1 with a cloth moistened with water. Is the problem recovered?	The task is complete.	Go to action 4b.
3c	Turn over the print media. Is the problem recovered?	The task is complete.	Go to action 4a.
4a	Use print media that is not damp. Is the problem recovered?	The task is complete.	Go to action 3a.
4b	Replace the print cartridges if you have a spare. See <a href="#">"Installing the Print Cartridges"</a> . Is the problem recovered?	The task is complete.	Contact Dell.

## Regi jam

Action		Yes	No
1	Ensure that the print cartridges are installed correctly. See <a href="#">"Installing the Print Cartridges"</a> . Is the problem recovered?	The task is complete.	Go to action 2.
2	Replace the print cartridges. See <a href="#">"Installing the Print Cartridges"</a> . Is the problem recovered?	The task is complete.	Contact Dell.

## Exit Jam

Ensure the fuser is installed correctly.

Action		Yes	No
1	Replace the fuser. See <a href="#">"Replacing the Fuser"</a> . Is the problem recovered?	The task is complete.	Go to action 2.
2	Replace the print cartridge. See <a href="#">"Installing the Print Cartridges"</a> . Is the problem recovered?	The task is complete.	Contact Dell.

## Multi-feed jam

Action		Yes	No
			If using Coated paper, go to action 2a.

1	Ensure that the tray 1 inserted properly. Is the problem recovered?	The task is complete.	If using other type of print media, go to action 2b.
2	Load Coated paper one sheet at a time. Is the problem recovered?	The task is complete.	Go to action 4b.
3	Is that the print media damp?	Go to action 4a.	Go to action 4b.
4a	Use print media that is not damp. Is the problem recovered?	The task is complete.	Go to action 4b.
4b	Fan the print media. Is the problem recovered?	The task is complete.	Go to action 5.
5	Wipe the retard roller in the tray 1 with a cloth moistened with water. Is the problem recovered?	The task is complete.	Contact Dell.

## Option Problem

If an option does not operate correctly following installation or stops working:

- Turn off the printer, wait for 10 seconds, and then turn on the printer. If this does not fix the problem, unplug the printer, and check the connection between the option and the printer.
- Print the printer settings page to see if the option is listed in the Installed Options list. If the option is not listed, reinstall it. See "[Printing a Printer Settings Page](#)".
- Ensure the option is selected in the printer driver you are using.

The following table lists printer's option and corrective action for related problem. If the suggested corrective action does not correct the problem, call customer service.

Problem	Action
550 sheet feeder	<ul style="list-style-type: none"> <li>• Ensure the 550 sheet feeder is correctly connected to the printer. Reinstall the feeder. See "<a href="#">Removing the 550 Sheet Feeder</a>" and "<a href="#">Installing the 550 Sheet Feeder</a>".</li> <li>• Ensure the print media is loaded correctly. See "<a href="#">Loading Print Media in the Standard and Optional Trays</a>" for more information.</li> </ul>
Duplexer	Ensure the duplexer is correctly installed. Reinstall the duplexer. See " <a href="#">Removing a Duplexer</a> " and " <a href="#">Installing a Duplexer</a> ".
Memory	Ensure the memory is securely connected to the memory connector.
Hard disk	Ensure the hard disk is securely inserted to the correct slot.
Network Protocol Adapter	Ensure the network protocol adapter is securely inserted to the correct slot.
Wireless printer adapter	Ensure the wireless printer adapter is securely inserted to the correct slot.

## Other Problems

Problem	Action
Condensation has occurred inside the	This usually occurs within several hours after you heat the room in winter. This also occurs when the printer is operating in a location where relative humidity reaches 85% or more. Adjust the humidity or relocate the printer to an appropriate environment.



## Contacting Service

When you call for printer service, be prepared to describe the problem you are experiencing or the error message on the display.

You need to know your printer's model type and serial number. See the label located inside the side door of your printer.

---

[Back to Contents Page](#)

# Installing Printer Drivers

- [Personal Printer Setup](#)
  - [Network Printer Setup](#)
  - [Printing and Checking the Printer Settings Page](#)
  - [Local Network Printer Setup](#)
  - [Remote Network Printer Setup](#)
  - [Setup Security](#)
  - [Troubleshooting Instructions](#)
- 

## Personal Printer Setup

1. Insert the *Drivers and Utilities* CD into your computer to start **Easy Setup Navigator**.

 **NOTE:** If the CD does not automatically launch, click **start**® **All Programs** (for Windows Vista and Windows 7)® **Accessories** (for Windows Vista and Windows 7)® **Run**, and then type `D:\setup_assist.exe` (where D is the drive letter of your CD), and then click **OK**.

2. Press **Software Installation** to launch the installation software.
3. Select **Personal Installation**, and then click **Next**.
4. Click **Install**.
5. Follow the instructions that appear on the **Found New Hardware Wizard** dialog box to install the printer driver on your computer.
6. When the **Completing the Found New Hardware Wizard** dialog box appears, click **Finish**.
7. Select either **Typical Installation** or **Custom Installation** from the installation wizard, and then click **Install**. If you select **Custom Installation**, you can select the specific software you want to install.
8. Click **Finish** to exit the wizard when the **Congratulations!** screen appears.

## USB Printing

A personal printer is a printer attached to your computer or a print server using a USB. If your printer is attached to a network and not your computer, see "[Network Printer Setup](#)".

---

## Network Printer Setup

 **NOTE:** To use this printer in a UNIX or Linux environment, you need to install a UX Filter or Linux Driver. For more information on how to install and use these, see "[Printing With UX Filter \(UNIX\)](#)" and "[Printing With CUPS \(Linux\)](#)".

 **NOTE:** When using a CD drive in a Linux environment, you need to mount the CD according to your system environment. The command strings are `mount/media/cdrom`.

## Disable Microsoft® Windows® XP, Windows Server® 2008, Windows Server 2008 R2, Windows Vista®, or Windows 7 Firewall Before Printer Software Installation

 **NOTE:** This step may not be necessary if you have Windows XP Service Pack 2 installed.

If your printer is connected directly to a network and the Windows 7, Windows Vista, Windows Server 2008 R2, Windows Server 2008, or Windows XP firewall is enabled, you cannot view your networked printer(s) when you run the Dell™ printer installation software. To prevent this situation, disable the Windows 7, Windows Vista, Windows Server 2008 R2, Windows Server 2008, or Windows XP firewall before you install the Dell printer software. To disable or enable your Windows 7, Windows Vista, Windows Server 2008 R2, Windows Server 2008, or Windows XP firewall, perform the following steps.

 **NOTICE:** It is recommended that you enable your Windows 7, Windows Vista, Windows Server 2008 R2, Windows Server 2008, or Windows XP firewall after you install the printer software. Enabling the Windows 7, Windows Vista, Windows Server 2008 R2, Windows Server 2008, or Windows XP firewall after you install the printer software does not limit the use of your printer.

1. Click the **start** button and click **Help and Support**.

 **NOTE:** For Windows Server 2008 R2 and Windows 7, if you use **Online Help**, switch to **Offline Help** on **Windows Help and Support** window.

2. In the **Search** box, type `firewall` and then press **Enter**.

In the list, click **Turn Windows Firewall on or off** and then follow the instructions on the screen.

---

## Printing and Checking the Printer Settings Page

Before installing the printer driver on your computer, print the printer settings page to check your printer's IP address.

### When Using the Operator Panel

1. Press **Menu** button.
2. Press ▼ button until `Report/List` appears, and then press ✓ (**Set**) button.
3. `Printer Setting` is displayed, and then Press ✓ (**Set**) button.

The printer settings page is printed.

4. Look under the **TCP/IP** heading on the printer settings page.

If the IP address is 0.0.0.0, wait for a few minutes to resolve the IP address automatically, and then print the printer settings page again.

If the IP address is not resolved automatically, refer to ["Assign an IP Address"](#).

---

## Local Network Printer Setup

1. Insert the *Drivers and Utilities* CD into your computer to start **Easy Setup Navigator**.

 **NOTE:** If the CD does not automatically launch, click **start**® **All Programs** (for Windows Vista and Windows 7)® **Accessories** (for Windows Vista and Windows 7)® **Run**, and then type `D:\setup_assist.exe` (where D is the drive letter of your CD), and then click **OK**.

2. Press **Software Installation** to launch the installation software.
3. Select **Network Installation**, and then click **Next**.
4. Select **Local Installation**, and then click **Next**.

5. Select the printer you want to install from the printer list, and then click **Next**. If the target printer is not displayed on the list, click **Refresh** to refresh the list or click **Add Printer** to add a printer to the list manually. You may specify the IP address and port name at this point.

If you have installed this printer on the server computer, select the **I am setting up this printer on a server** check box.

 **NOTE:** When using AutoIP, 0.0.0.0 is displayed in the installer. Before you can continue, you must enter a valid IP address.

 **NOTE:** In some cases, **Windows Security Alert** is displayed in this step when you use Windows Vista, Windows Vista 64-bit Edition, Windows Server 2008, Windows Server 2008 64-bit Edition, Windows Server 2008 R2 64-bit Edition, Windows 7, or Windows 7 64-bit Edition. In this case, select **Unblock (Allow access for Windows Server 2008 R2 and Windows 7)**, and then continue the procedure.

6. Specify the printer settings, and then click **Next**.
  - a. Enter the printer name.
  - b. If you want other users on the network to access this printer, select **Share this printer with other computers on the network**, and then enter a share name that users will easily identify.
  - c. If you want to set a printer as the default, select the **Set this printer as default** check box.
  - d. If you want to restrict color printing, select the appropriate **Dell ColorTrack** option. Enter the password when **Color-Password Enabled** is selected for **Dell ColorTrack**.
  - e. If you want to install the PostScript driver, select the **PostScript Driver** check box.
7. Select the software and documentation you want to install, and then click **Next**. You can specify folders in which to install the Dell software and documentation. To change the folders, click **Browse**.
8. Click **Finish** to exit the wizard when the **Congratulations!** screen appears. If necessary, click **Print Test Page** to print a test page.

Use the **Dell Printer Configuration Web Tool** to monitor the status of your network printer without leaving your desk. You can view and/or change the printer configuration settings, monitor toner level, and when it is time to order replacement consumables, just click the Dell supplies link right from your Web browser.

 **NOTE:** The **Dell Printer Configuration Web Tool** is not available when the printer is locally attached to a computer or a print server.

To launch the **Dell Printer Configuration Web Tool**, type the printer's IP address in your Web browser, and the printer configuration appears on the screen.

You can set up the **Dell Printer Configuration Web Tool** to send you an email when the printer needs supplies or intervention.

To set up e-mail alerts:

1. Launch the **Dell Printer Configuration Web Tool**.
2. Click **E-Mail Alert** link.
3. Under **Setup E-Mail Lists and Alerts**, enter the **Primary SMTP Gateway**, the **Reply Address**, and enter your email address or the key operator's email address in the email list box.
4. Click **Apply New Settings**.

 **NOTE:** The SMTP server will display **Connection in Progress** until an error occurs.

---

## Remote Network Printer Setup

### Before Installation

Before you start remote installation, perform the following procedures.

## Allow Print Spooler to Accept Client Connections

 **NOTE:** This step is required for Windows Vista, Windows Vista 64-bit Edition, Windows XP, Windows XP 64-bit Edition, Windows Server 2003, Windows Server 2003 x64 Edition, Windows Server 2008, Windows Server 2008 64-bit Edition, Windows Server 2008 R2 64-bit Edition, Windows 7, and Windows 7 64-bit Edition.

### For Windows XP, Windows Vista, Windows Server 2003, and Windows Server 2008:

1. Click **start**® **All Programs** (for Windows Vista only)® **Accessories** (for Windows Vista only)® **Run**.
2. Type `gpedit.msc`, and then click **OK**.
3. Click **Computer Configuration**® **Administrative Templates**® **Printers**.
4. Right-click **Allow Print Spooler to accept client connections** and select **Properties**.
5. From the **Setting** tab, select **Enabled**, and then click **OK**.
6. Restart the computer.

### For Windows Server 2008 R2 and Windows 7:

1. Click **Start**® **All Programs** (for Windows 7 only)® **Accessories** (for Windows 7 only)® **Run**.
2. Type `gpedit.msc`, and then click **OK**.
3. Click **Computer Configuration**® **Administrative Templates**® **Printers**.
4. Right-click **Allow Print Spooler to accept client connections** and select **Edit**.
5. Select **Enabled**, and then click **OK**.
6. Restart the computer.

## Share the Firewall File and Printer

 **NOTE:** This step is required for Windows Vista, Windows Vista 64-bit Edition, Windows XP, Windows XP 64-bit Edition, Windows Server 2008, Windows Server 2008 64-bit Edition, Windows Server 2008 R2 64-bit Edition, Windows 7, and Windows 7 64-bit Edition.

### For Windows Vista:

1. Click **start**® **Control Panel**.
2. Select **Security**.
3. Click **Windows Firewall**.
4. Click **Change settings**.
5. Click **Continue**.
6. From the **Exceptions** tab, check the **File and Printer Sharing** check box, and then click **OK**.

### For Windows Server 2008:

1. Click **start® Control Panel**.
2. Double-Click **Windows Firewall**.
3. Click **Change settings**.
4. From the **Exceptions** tab, check the **File and Printer Sharing** check box, and then click **OK**.

#### **For Windows Server 2008 R2 and Windows 7:**

1. Click **Start® Control Panel**.
2. Select **System and Security**.
3. Click **Windows Firewall**.
4. Click **Allow a program or feature through Windows Firewall**.
5. If the check boxes under **Allowed programs and features:** are dimmed, click **Change settings**.
6. Check the **File and Printer Sharing** check box. **Home/Work (Private)** or **Public** check box is automatically selected according to your settings.  
If **File and Printer Sharing Properties** dialog box appears, click **OK**.
7. Click **OK**.

#### **For Windows XP:**

1. Click **start® Control Panel**.
2. Select **Security Center**.
3. Click **Windows Firewall**.
4. From the **Exceptions** tab, check the **File and Printer Sharing** check box, and then click **OK**.

### **Start Remote Registry**



**NOTE:** This step is required for Windows Vista, Windows Vista 64-bit Edition, Windows 7, and Windows 7 64-bit Edition.

1. Click **Start® Control Panel**.
2. Select **System and Maintenance (System and Security for Windows 7)**.
3. Click **Administrative Tools**.
4. Double-click **Services**.
5. Click **Continue** (for Windows Vista only).
6. Right-click **Remote Registry** and select **Start**.
7. Right-click **Remote Registry** and select **Properties**.
8. Change **Startup type:** to **Automatic**, and then click **OK**.

### **Disable User Account Control**

 **NOTICE:** Disabling the User Account Control might leave the system vulnerable to virus attacks.

 **NOTE:** This step is required for Windows Vista, Windows Vista 64-bit Edition, Windows Server 2008, Windows Server 2008 64-bit Edition, Windows Server 2008 R2 64-bit Edition, Windows 7, and Windows 7 64-bit Edition.

### For Windows Vista:

1. Click **start® Control Panel**.
2. Select **User Accounts and Family Safety**.
3. Click **User Accounts**.
4. Click **Turn User Account Control on or off**.
5. Click **Continue**.
6. Clear the **Use User Account Control (UAC) to help protect your computer** check box.
7. Restart the computer.

### For Windows Server 2008:

1. Click **start® Control Panel**.
2. Double-Click **User Accounts**.
3. Click **Turn User Account Control on or off**.
4. Clear the **Use User Account Control (UAC) to help protect your computer** check box.
5. Click **OK**.
6. Restart the computer.

### For Windows Server 2008 R2:

1. Click **Start® Control Panel**.
2. Select **User Accounts**.
3. Click **User Accounts**.
4. Click **Change User Account Control Settings**.
5. Move the slider to the bottom, and then click **OK**.
6. Restart the computer.

### For Windows 7:

1. Click **Start® Control Panel**.
2. Select **User Accounts and Family Safety**.
3. Click **User Accounts**.
4. Click **Change User Account Control Settings**.
5. Move the slider to the bottom, and then click **OK**.
6. Click **Yes** in **User Account Control** dialog box.

7. Restart the computer.

## Enable Network Discovery and File Sharing for all Public Networks

You can skip "Disable User Account Control" for this procedure.

 **NOTE:** This step is required when you use Windows Vista, Windows Vista 64-bit Edition, Windows Server 2008, Windows Server 2008 64-bit Edition, Windows Server 2008 R2 64-bit Edition, Windows 7, and Windows 7 64-bit Edition for the server computer.

1. Click **Start® Network (Start® your user name® Network** for Windows 7).
2. Click **Network discovery and file sharing are turned off. Network computers and devices are not visible. Click to change.**
3. Click **Turn on network discovery and file sharing.**
4. Click **Yes, turn on network discovery and file sharing for all public networks.**

## Disable Simple File Sharing

 **NOTE:** This step is required for Windows XP, and Windows XP 64-bit Edition.

1. Click **start® Control Panel.**
2. Select **Appearance and Themes.**
3. Select **Folder Options.**
4. From the **View** tab, clear the **Use simple file sharing(Recommended)** check box, and then click **OK.**
5. Click **start® Control Panel.**
6. Select **Performance and Maintenance.**
7. Select **Administrative Tools.**
8. Click **Local Security Policy.**
9. Click **Local Policies® Security Options.**
10. Right-click **Network access: Sharing and security model for local accounts** and select **Properties.**
11. Ensure **Classic - local users authenticate as themselves** is selected.

## Installing the Printer Driver

 **NOTE:** Installation on Windows XP Home Edition, Windows Vista Home Basic, Windows Vista Home Premium, Windows Vista x64 Home Basic, Windows Vista x64 Home Premium, Windows 7 Starter, Windows 7 Home Basic, Windows 7 Home Premium, Windows 7 x64 Home Basic, and Windows 7 x64 Home Premium is not supported.

1. Insert the *Drivers and Utilities* CD into your computer to start **Easy Setup Navigator.**

 **NOTE:** If the CD does not automatically launch, click **start® All Programs** (for Windows Vista and Windows 7)® **Accessories** (for Windows Vista and Windows 7)® **Run**, and then type `D:\setup_assist.exe` (where D is the drive letter of your CD), and then click **OK.**

2. Press **Software Installation** to launch the installation software.



3. Select **Network Installation**, and then click **Next**.
4. Select **Remote Installation**, and then click **Next**.
  - a. Enter the computer name, user ID, and password. Then, click **Add**.
  - b. Click **Next**.

 **NOTE:** In some cases, **Windows Security Alert** is displayed in this step when you use Windows Vista, Windows Vista 64-bit Edition, Windows Server 2008, Windows Server 2008 64-bit Edition, Windows Server 2008 R2 64-bit Edition, Windows 7, or Windows 7 64-bit Edition. In this case, select **Unblock (Allow access for Windows Server 2008 R2 and Windows 7)**, and then continue the procedure.

5. Select the printer you want to install from the printer list, and then click **Next**. If the target printer is not displayed on the list, click **Refresh** to refresh the list or click **Add Printer** to add a printer to the list manually. You may specify the IP address and port name at this point.

 **NOTE:** When using AutoIP, 0.0.0.0 is displayed in the installer. Before you can continue, you must enter a valid IP address.

6. Specify the printer settings, and then click **Next**.
  - a. Enter the printer name.
  - b. If you want other users on the network to access this printer, select **Share this printer with other computers on the network**, and then enter a share name that users will easily identify.
  - c. If you want to set a printer as the default, select the **Set this printer as default** check box.
  - d. If you want to restrict color printing, select the appropriate **Dell ColorTrack** option. Enter the password when **Color-Password Enabled** is selected for **Dell ColorTrack**.
7. Select the software and documentation you want to install, and then click **Next**. You can specify folders in which to install the Dell software and documentation. To change the folders, click **Input**.
8. Click **Finish** to exit the wizard when the **Congratulations!** screen appears.

Use the **Dell Printer Configuration Web Tool** to monitor the status of your network printer without leaving your desk. You can view and/or change the printer configuration settings, monitor toner level, and when it is time to order replacement consumables, just click the Dell supplies link right from your Web browser.

 **NOTE:** The **Dell Printer Configuration Web Tool** is not available when the printer is locally attached to a computer or a print server.

To launch the **Dell Printer Configuration Web Tool**, type the printer's IP address in your Web browser, and the printer configuration appears on the screen.

You can set up the **Dell Printer Configuration Web Tool** to send you an email when the printer needs supplies or intervention.

To set up e-mail alerts:

1. Launch the **Dell Printer Configuration Web Tool**.
2. Click **E-Mail Alert** link.
3. Under **E-Mail Server Settings**, enter the **Primary SMTP Gateway**, the **Reply Address**, and enter your email address or the key operator's email address in the email list box.
4. Click **Apply New Settings**.

 **NOTE:** The SMTP server will display **Connection pending until printer sends an alert** until an error occurs.

1. Press **Menu** button.
2. Press ▼ button until `Admin Menu` appears, and then press ✓ **(Set)** button.
3. Press ▼ button until `Panel Settings` appears, and then press ✓ **(Set)** button.
4. `Panel Lock` is displayed. Press ✓ **(Set)** button.
5. Press ▼ button until `Enable` appears, and then press ✓ **(Set)** button.
6. Press **Cancel** button to return to the previous menu.
7. Press ▼ button until `Change Password` appears, and then press ✓ **(Set)** button.
8. Reenter the password to confirm the password that you entered, and then press ✓ **(Set)** button.

The password has been changed.

 **NOTE:** If you forget your password, turn off the printer. Then, while holding **Menu** button turn on the printer. Continue to hold **Menu** button until the display indicates `Init Password`. This will recover the factory default panel password.  
Note that the password for `Panel Lock` is disabled.

 **NOTE:** If `Panel Lock` is `Enable`, the factory-default panel password is 0000.

<b>Panel Lock</b>	<b>Disable*</b>	Does not lock <code>Admin Menu</code> with a password.
	<b>Enable</b>	Locks <code>Admin Menu</code> with a password.
<b>Change Password</b>	<b>0000*</b>	Sets or changes the password required to access <code>Admin Menu</code> .
	<b>0000-9999</b>	

## Troubleshooting Instructions

### Resetting Defaults

After executing this function and rebooting the printer, all the menu parameters, except the parameters for the network, are reset to their default values.

### When Using the Operator Panel

1. Press **Menu** button.
2. Press ▼ button until `Admin Menu` appears, and then press ✓ **(Set)** button.
3. Press ▼ button until `Maintenance` appears, and then press ✓ **(Set)** button.
4. Press ▼ until `Reset Defaults` appears, and then press ✓ **(Set)** button.
5. The `Are you sure?` message appears on the operator panel. Press ✓ **(Set)** button.
6. Turn off the printer to apply the settings.

### When Using the Tool Box

1. Click **start® All Programs® Dell Printers® Dell 3130cn Color Laser Printer® Tool Box**.

The **Select Printer** dialog box opens.

2. Click **Dell 3130cn Color Laser PCL 6** listed in **Printer Name**, and then click **OK**.

The **Tool Box** opens.

3. Click the **Printer Maintenance** tab.
4. Select **Reset Defaults** from the list at the left side of the page.

The **Reset Defaults** page is displayed.

5. Click **Start**.

The printer is turned off automatically to apply the settings.

---

[Back to Contents Page](#)

# Printing With Web Services on Devices (WSD)

- [Adding Roles of Print Services](#)
- [Printer Setup](#)

This section provides information for network printing with WSD, the new Windows Vista<sup>®</sup>, Windows Server<sup>®</sup> 2008, Windows Server 2008 R2, and Windows<sup>®</sup> 7 protocol of Microsoft<sup>®</sup>.

---

## Adding Roles of Print Services

When you use Windows Server 2008 or Windows Server 2008 R2, you need to add the roles of print services to the Windows Server 2008 or Windows Server 2008 R2 client.

### For Windows Server 2008:

1. Click **Start**<sup>®</sup> **Administrative Tools**<sup>®</sup> **Server Manager**.
2. Select **Add Roles** from the **Action** menu.
3. Check the **Print Services** check box on the **Server Roles** window in the **Add Roles Wizard**, and then click **Next**.
4. Check the **Print Server** check box, and then click **Next**.
5. Click **Install**.

### For Windows Server 2008 R2:

1. Click **Start**<sup>®</sup> **Administrative Tools**<sup>®</sup> **Server Manager**.
  2. Select **Add Roles** from the **Action** menu.
  3. Check the **Print and Document Services** check box on the **Server Roles** window in the **Add Roles Wizard**, and then click **Next**.
  4. Click **Next**.
  5. Check the **Print Server** check box, and then click **Next**.
  6. Click **Install**.
- 

## Printer Setup

You can install your new printer on the network using the *Drivers and Utilities* CD that shipped with your printer, or using Microsoft's Windows **Add Printer** wizard.

## Installing a Printer Driver Using the Add Printer Wizard

1. Click **Start**<sup>®</sup> **Control Panel**<sup>®</sup> **Hardware and Sound**<sup>®</sup> **Printers** (**Start**<sup>®</sup> **Devices and Printers** for Windows Server 2008 R2 and Windows 7).
2. Click **Add a printer** to launch the **Add Printer** wizard.
3. Select **Add a network, wireless or Bluetooth printer**.

4. In the list of available printers, select the one you want to use, and then click **Next**.

 **NOTE:** In the list of available printers, the WSD printer is displayed in the form of **http://IP address/ws/**.

 **NOTE:** If no WSD printer is displayed in the list, enter the printer's IP address manually to create a WSD printer. To enter the printer's IP address manually, follow the instructions below.

For Windows Server 2008 R2, to create a WSD printer, you must be a member of Administrators group.

1. Click **The printer that I want isn't listed**.

2. Select **Add a printer using a TCP/IP address or hostname** and click **Next**.

3. Select **Web Services Device** from **Device type**.

4. Enter the printer's IP address in the **Hostname or IP address** text box and click **Next**.

5. If prompted, install the printer driver on your computer. If you are prompted for an administrator password or confirmation, type the password or provide confirmation.

6. Complete the additional steps in the wizard, and then click **Finish**.

7. Print a test page to verify print installation.

a. Click **Start® Control Panel® Hardware and Sound® Printers (Start® Devices and Printers** for Windows Server 2008 R2 and Windows 7).

b. Right-click the printer you just created, and then click **Properties (Printer properties** for Windows Server 2008 R2 and Windows 7).

**For PCL driver:**

On the **Options** tab, set each setting item, and then click **Apply**.

**For PS driver:**

On the **Device Settings** tab, set each setting item, and then click **Apply**.

c. On the **General** tab, click **Print Test Page**. When a test page prints successfully, installation is complete.

## Maintaining Your Printer

- [Determining the Status of Supplies](#)
- [Conserving Supplies](#)
- [Ordering Supplies](#)
- [Storing Print Media](#)
- [Storing Consumables](#)
- [Replacing Print Cartridges](#)
- [Replacing the Fuser](#)
- [Replacing Separator Roller](#)
- [Replacing the Belt Unit](#)
- [Adjusting Color Registration](#)

Periodically, your printer requires you to complete certain tasks to maintain optimum print quality. If several people are using the printer, you may want to designate a key operator to maintain your printer. Refer printing problems and maintenance tasks to this key operator.

---

## Determining the Status of Supplies

If your printer is connected to the network, the **Dell™ Printer Configuration Web Tool** can provide instant feedback on remaining toner levels. Type the printer's IP address in your Web browser to view this information. To use the **E-Mail Alert Setup** feature that notifies you when the printer requires new supplies, type your name or the name of the key operator in the e-mail list box.

On the operator panel, you can also confirm the following:

- Any supply or maintenance items that require attention replacing (However, the printer can only display information about one item at a time.)
  - Amount of toner remaining in each print cartridge
- 

## Conserving Supplies

You can change several settings in your printer driver to conserve print cartridge and paper.

Supply	Setting	Function
Print cartridge	<b>Toner Saving Mode</b> in the <b>Advanced</b> tab of the printer driver	This check box allows the users to select a print mode that uses less toner. When this feature is used, the image quality will be lower than when it is not used.
Print media	<b>Multiple Up</b> in the <b>Layout</b> tab of the printer driver	The printer prints two or more pages on one side of a sheet. Values for <b>Multiple Up</b> are 2 Up, 4 Up, 8 Up, 16 Up, or 32 Up. Combined with the duplex setting, <b>Multiple Up</b> allows you to print up to 64 pages on one sheet of paper. (32 images on the front and 32 on the back)

---

## Ordering Supplies

You can order consumables from Dell on the Internet when using a networked printer. Type the IP address of your printer in your Web browser, launch the **Dell Printer Configuration Web Tool**, and click the **Order Supplies at:** to order toner for your printer.

You can also order print cartridges by the following method.

1. Click **start® All Programs® Dell Printers® Additional Color Laser Software® Dell Supplies Management System**.

The **Dell Supplies Management System** window appears.

2. Select your printer from the **Select Printer Model** list.
  3. If ordering from the Web:
    - a. When you cannot get information from the printer automatically by two-way communication, a window that prompts you to type the Service Tag number appears. Type your Dell printer Service Tag number in the field provided.

Your Service Tag number is located inside the front cover of your printer.
    - b. Select a URL from the **Select Reorder URL** list.
    - c. Click **Visit Dell printer supplies ordering web site**.
  4. If ordering by phone, call the number that appears under the **Order by Phone** heading.
- 

## Storing Print Media

To avoid potential paper feeding problems and uneven print quality, there are several things you can do.

- To achieve the best possible print quality, store print media in an environment where the temperature is approximately 21°C (70°F) and the relative humidity is 40%.
  - Store cartons of print media on a pallet or shelf, rather than directly on the floor.
  - If you store individual packages of print media out of the original carton, ensure that they rest on a flat surface so the edges do not buckle or curl.
  - Do not place anything on top of the print media packages.
- 

## Storing Consumables

Store consumables in their original packaging until you need to use them. Do not store consumables in:

- Temperatures greater than 40°C (104°F).
  - An environment with extreme changes in humidity or temperature.
  - Direct sunlight.
  - Dusty places.
  - A car for a long period of time.
  - An environment where corrosive gases are present.
  - An environment with salty air.
- 

## Replacing Print Cartridges



**CAUTION:** Before performing any of the following procedures, read and follow the safety instructions in your *Product Information Guide*.



**NOTICE:** To protect the drums of the print cartridges against bright light, close the front cover within five minutes.

If the front cover remains open for more than five minutes, print quality may deteriorate.

Dell print cartridges are available only through Dell. You can order more cartridges online at <http://www.dell.com/supplies> or by phone. To order by phone, see "[Contacting Dell](#)".

It is recommended that you use Dell print cartridges for your printer. Dell does not provide warranty coverage for problems caused by using accessories, parts, or components not supplied by Dell.

**⚠ CAUTION:** Never throw used print cartridges into fire. The residual toner could explode resulting in burns and injuries.

**⚠ CAUTION:** Do not shake the used print cartridge to avoid spilling of toner.

## Removing the Used Print Cartridge

1. Open the side button and open the front cover.

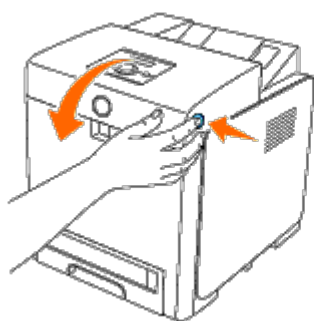

2. Grasp the handles at both ends of the print cartridge that you want to replace and pull it out.

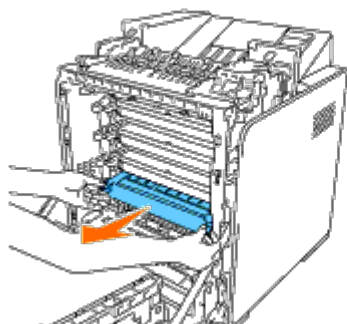

**⚠ CAUTION:** Do not shake the print cartridge as it may spill some toner.

## Installing a New Print Cartridge

1. Ensure that the color of the new print cartridge matches that on the handle before replacing it. Shake the print cartridge five or six times to distribute the toner evenly.

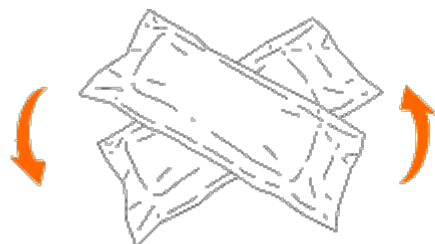

2. Remove the print cartridge from its packaging.



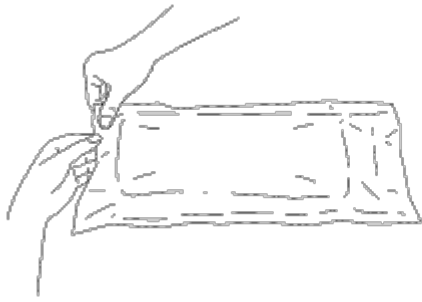

**NOTE:** To protect the drum against bright light, do not remove the orange protective cover of the print cartridge before the cartridge is inserted into its slot in the printer.

3. Completely remove the seal from the print cartridge by pulling the tab on the end of the print cartridge. It is approximately 856 mm long.

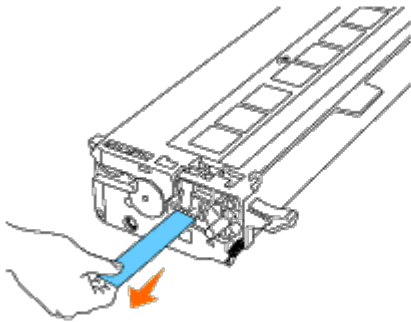

**NOTE:** Pull the seal out straight. Pulling the seal diagonally may tear it.

4. Grasp both handles of the print cartridge with the label facing up and slide the cartridge into the same color slot. Ensure the cartridge is fully inserted.

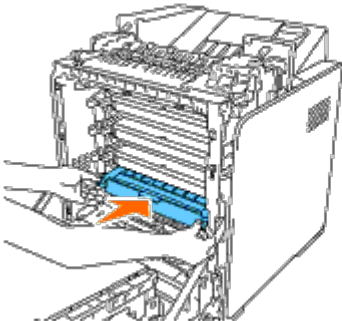



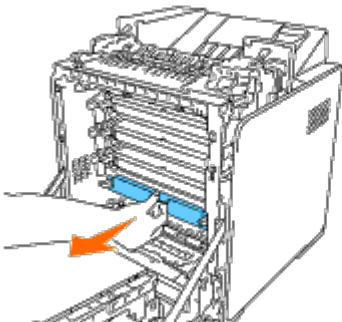

5. Remove the orange protective cover of the installed print cartridge and discard.

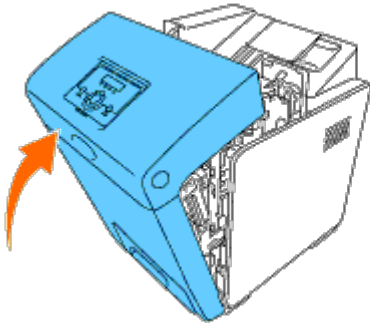

6. Close the front cover.



## Replacing the Fuser

-  **CAUTION:** A CAUTION indicates a potential for property damage, personal injury, or death.
-  **CAUTION:** To prevent electric shock, always turn off the printer and disconnect the power cable from the grounded outlet before performing maintenance.
-  **CAUTION:** Before performing any of the following procedures, read and follow the safety instructions in your *Product Information Guide*.
-  **NOTICE:** To protect the drums of the print cartridges against bright light, close the front cover within five minutes. If the front cover remains open for more than five minutes, print quality may deteriorate.
-  **NOTE:** Remove any print jobs from the center output tray, and close the multipurpose feeder (MPF) before opening the front cover.

Dell fuser is available only through Dell. To order by phone, see ["Contacting Dell"](#).

It is recommended to use a Dell fuser for your printer. Dell does not provide warranty coverage for problems caused by using accessories, parts, or components not supplied by Dell.

## Removing the Used Fuser

-  **CAUTION:** To avoid burns, do not replace the fuser immediately after printing, as the fuser gets very hot during this process.

1. Turn off the printer and wait for 30 minutes for the fuser to cool down before removal.
2. Push the side button and open the front cover.

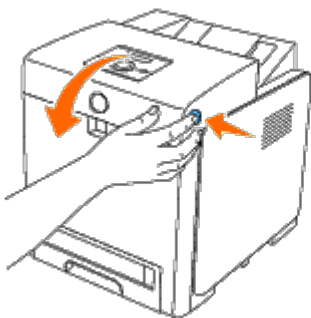

3. Lift the chute gate to its upright position.

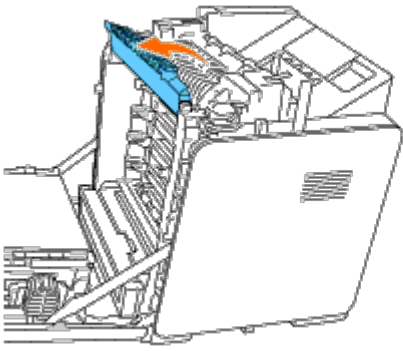

4. Release the levers by lifting them upwards and then outwards at both ends of the fuser.

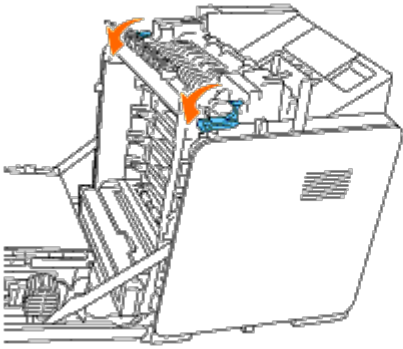

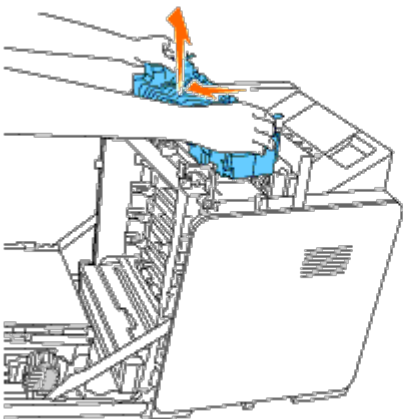

5. Hold both sides of the installed fuser, pull it towards the front of the printer to release the connection on the right side, then lift upward to remove.

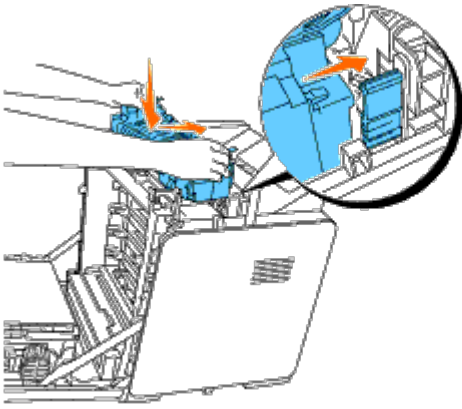

## Installing a New Fuser

1. Unpack a new fuser and hold both sides of the fuser with both hands.
2. With the connector of the fuser toward the slot, push the connector into the slot firmly.



 **NOTE:** Ensure that the fuser connector is firmly seated.

3. Lock both levers at the ends of the fuser.

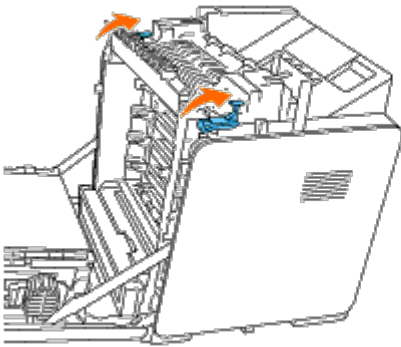

4. Lower the chute gate to its horizontal position.

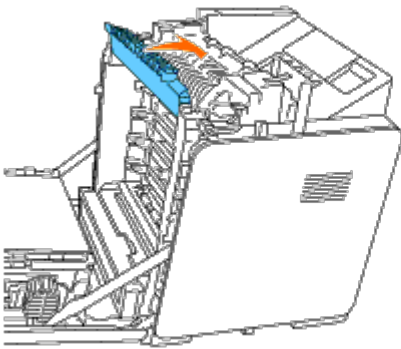

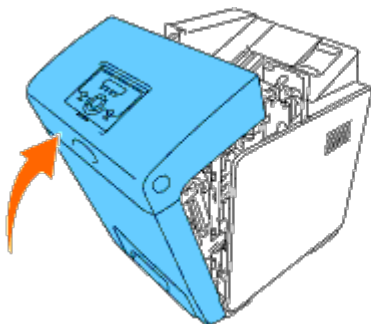

5. Close the front cover.



---

## Replacing Separator Roller

There are three separator rollers in the printer which need to be replaced periodically. One is in the tray and the others are inside the printer. All the separator rollers are replaced in the same way as described in this section.

-  **CAUTION:** To prevent electric shock, always turn off the printer and disconnect the power cable from the grounded outlet before performing maintenance.
-  **CAUTION:** Before performing any of the following procedures, read and follow the safety instructions in your *Product Information Guide*.

Dell separator rollers are available only through Dell. To order by phone, see ["Contacting Dell"](#).

It is recommended to use a Dell separator roller for your printer. Dell does not provide warranty coverage for problems caused by using accessories, parts, or components not supplied by Dell.

## Removing the Used Separator Roller in the Tray 1

-  **NOTE:** Remove all paper or media from the tray before pulling the tray out of the printer.

1. Pull the tray 1 out of the printer carefully. Hold the tray with both hands, lift the front slightly, and pull it out of the printer.

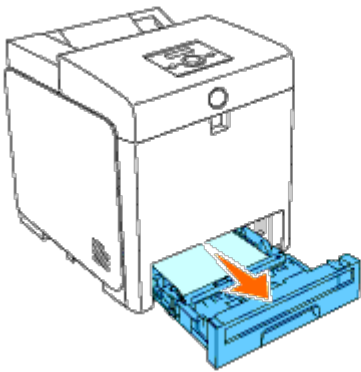

-  **NOTE:** Ensure that you remove all the paper from the tray 1 before removing the separator roller.

-  **NOTE:** Carefully replace the tray 1 so it does not fall down.

2. Push the handles back on each side of the separator roller cover as shown in the following illustration and open the cover.

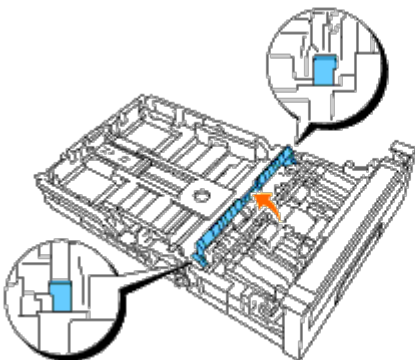

3. Turn the separator roller until the roller hook is visible.

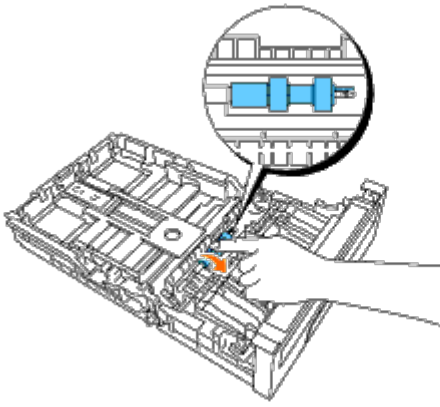

4. Pull the separator roller hook out of the groove in the axle, and then slide the separator roller to the right.

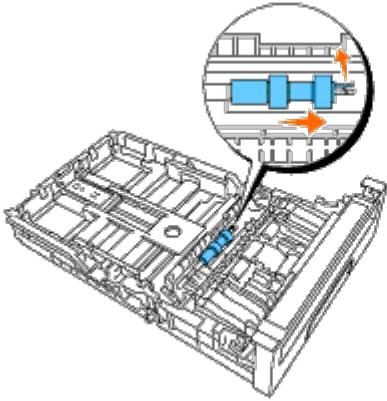

## Installing the New Separator Roller in the Tray 1

1. Align the hole of the new separator roller with the axle.

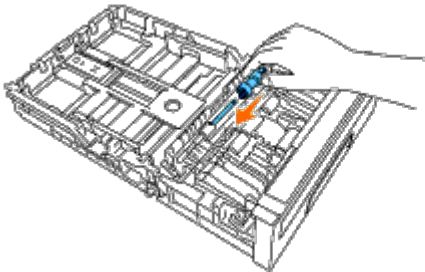

2. Slide the separator roller along the axle so the protrusions fit completely into the slots and the roller hook re-seats into the groove on the axle.

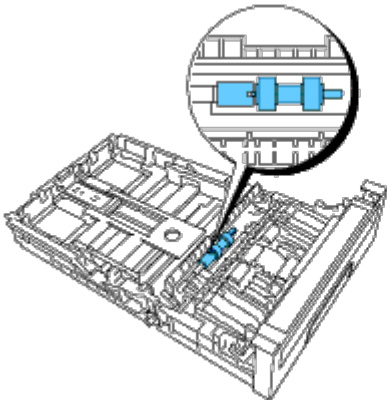

3. Close the separator roller cover until both sides click into place.

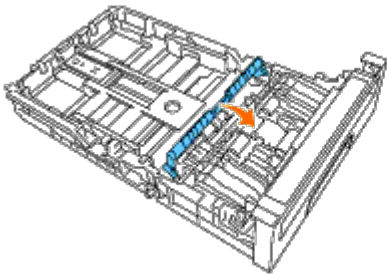

4. Load paper into the tray 1 and insert it into the printer.

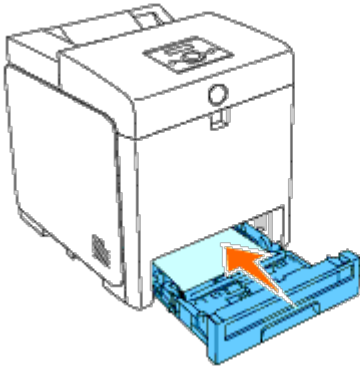

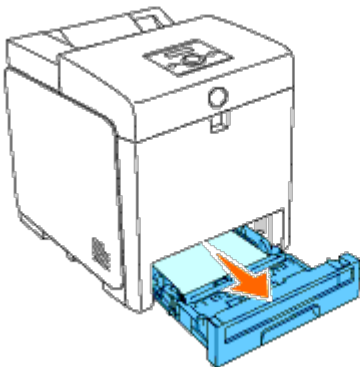

## Removing the Used Separator Roller Inside the Printer

1. Pull the tray 1 out of the printer carefully. Hold the tray with both hands, lift the front slightly, and pull it out of the printer.

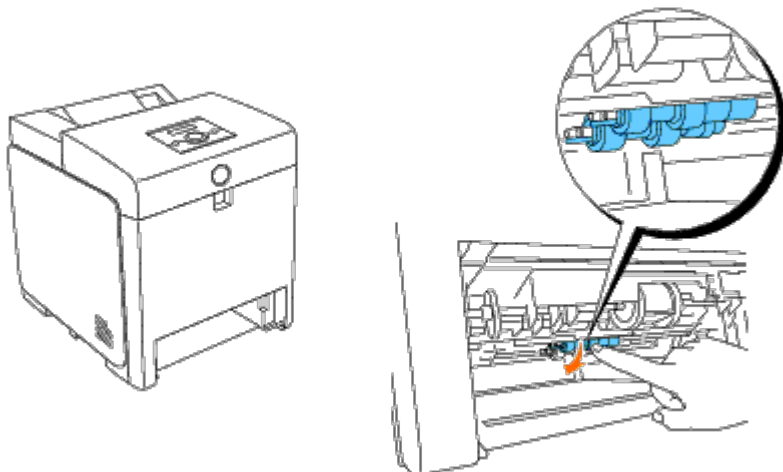

2. Turn the separator roller until the roller hook can be seen.



 **NOTE:** The roller is located approximately 165 mm (6.5 in.) inside the printer as measured from the face of

the paper tray opening.

3. Pull the separator roller hook out of the groove on the axle, and then slide the separator roller to the left.

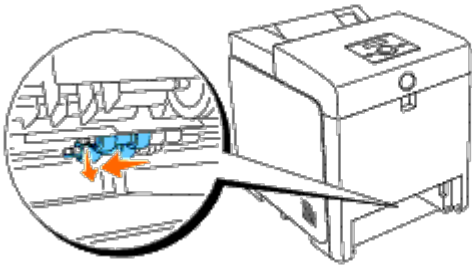

4. Repeat steps 2 and 3 to remove the other separator roller from the inside of the printer.

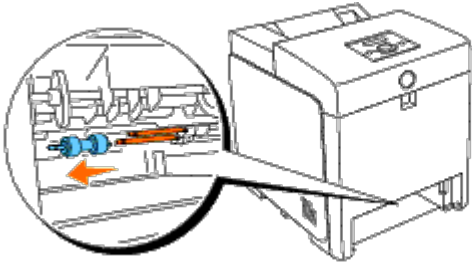

## Installing the New Separator Roller Inside the Printer

1. Align the hole of the new separator roller with the axle.

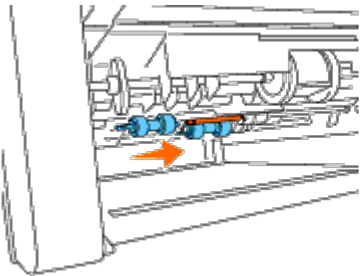

2. Slide the separator roller along the axle so the protrusions fit completely into the slots and the roller hook reseats into the groove on the axle.

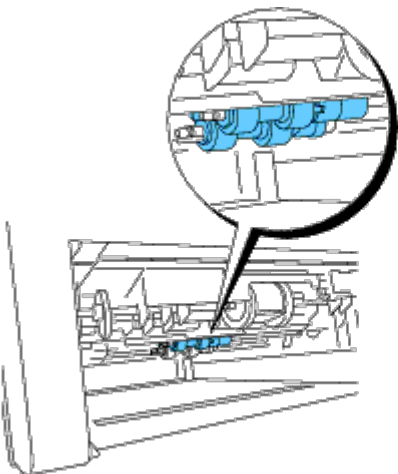

3. Insert the tray into the printer.



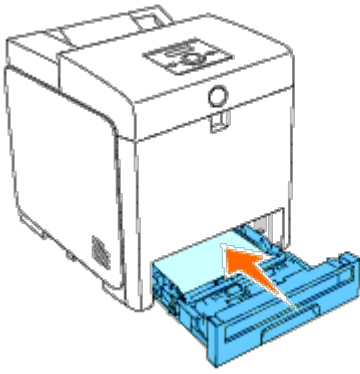

## Replacing the Belt Unit

**⚠ CAUTION:** Before performing any of the following procedures, read and follow the safety instructions in your *Product Information Guide*.

**➡ NOTICE:** Ensure nothing touches or scratches the surface (black-colored film) of the belt unit. Scratches, dirt, or oil from your hands on the film of the belt unit may reduce print quality.

**➡ NOTICE:** To protect the drums of the print cartridges against bright light, close the front cover within five minutes. If the front cover remains open for more than five minutes, print quality may deteriorate.

Dell belt units are available only through Dell. To order by phone, see ["Contacting Dell"](#). It is recommended to use a Dell belt unit for your printer. Dell does not provide warranty coverage for problems caused by using accessories, parts, or components not supplied by Dell.

## Removing the Used Belt Unit

**✍ NOTE:** Remove any print jobs from the center output tray, and close the MPF cover before opening the front cover.

**⚠ CAUTION:** Do not touch the inside of the printer. Some parts may be hot. Allow time for the printer to cool before attempting to remove parts in this area.

1. Ensure that the printer is turned off.
2. Push the side button and open the front cover.

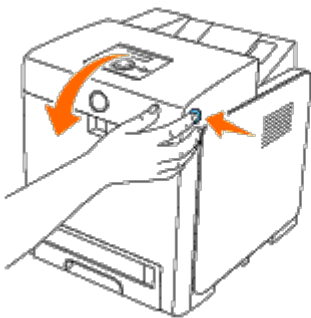

3. Pull up on the belt release levers and rotate the belt unit up as shown in the illustration.

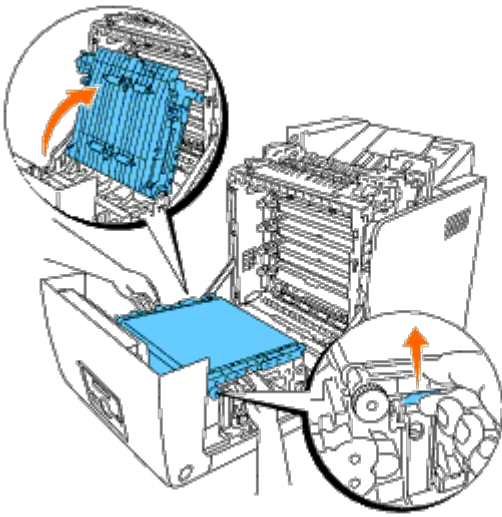

4. Hold both sides of the belt unit with both hands and pull up the right side of the unit until the peg on the right side comes out of the groove. Then, shift the belt unit to the right and remove the unit from the printer.

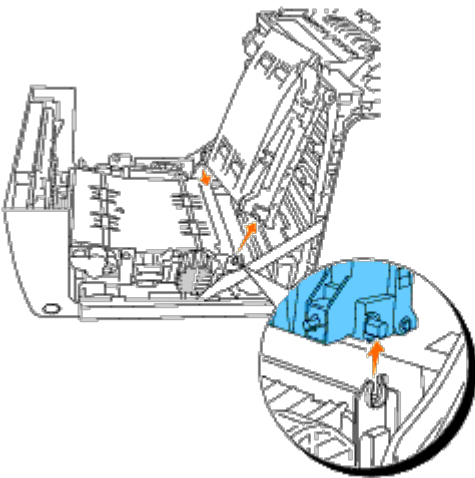

## Installing a New Belt Unit

1. Unpack a new belt unit.
2. Insert the left peg into the corresponding left side belt unit hole, then align the right peg with the groove, and then push down on the right side of the belt unit to seat into place.

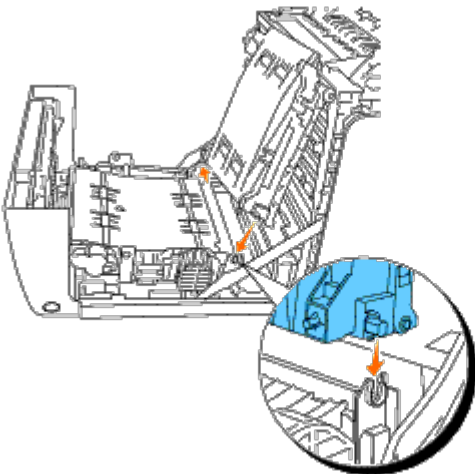

3. Close the belt unit by pulling it down until it clicks.

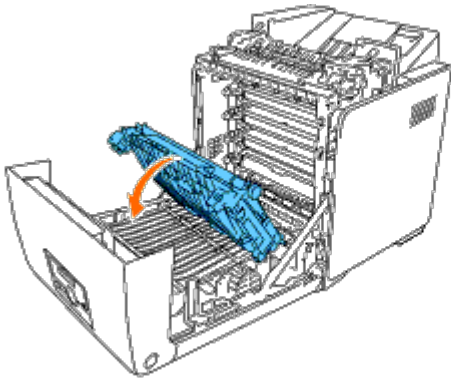

4. Remove the film cover from the installed belt unit and discard.

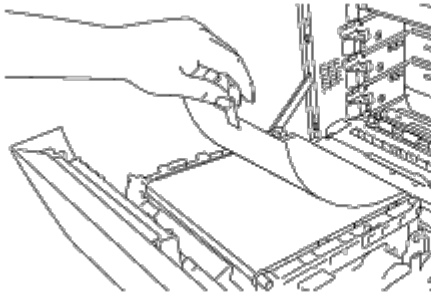

5. Close the front cover.

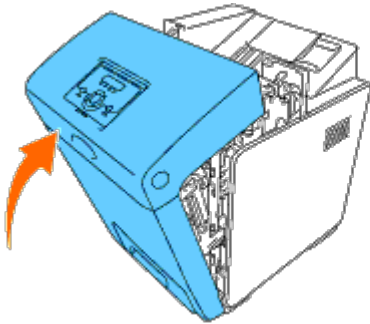

---

## Adjusting Color Registration

To adjust the color registration when you first install the printer or after moving it to a new location, follow the procedure below.

### Printing the Color Registration Chart

#### When Using the Operator Panel

1. Press **Menu** button.
2. Press ▼ button until Admin Menu appears, and then press ✓ **(Set)** button.
3. Press ▼ button until Maintenance appears, and then press ✓ **(Set)** button.
4. Press ▼ button until Color Reg Adj appears, and then press ✓ **(Set)** button.
5. Press ▼ button until Color Regi Chart appears, and then press ✓ **(Set)** button.

The color registration chart is printed.

## When Using the Tool Box

1. Click **start® All Programs® Dell Printers® Dell 3130cn Color Laser Printer® Tool Box**.

The **Select Printer** dialog box opens.

2. Click **Dell 3130cn Color Laser PCL 6** listed in **Printer Name**, and then click **OK**.

The **Tool Box** opens.

3. Click the **Printer Maintenance** tab.
4. Select **Registration Adjustment** from the list at the left side of the page.

The **Registration Adjustment** page is displayed.

5. Click the **Start** button next to **Color Regi Chart**.

The color registration chart is printed.

## Determining Values

From the lines to the right of the **Y** (Yellow), **M** (Magenta), and **C** (Cyan) pattern, find the values of the straightest lines.

 **NOTE:** You can also use the densest colors of the lattice pattern to find the straightest lines. The colors printed at the highest density are those next to the straightest lines. When 0 is the value nearest the straightest line, you do not need to adjust the color registration. When the value is not 0, follow the procedure outlined in "[Entering Values](#)".

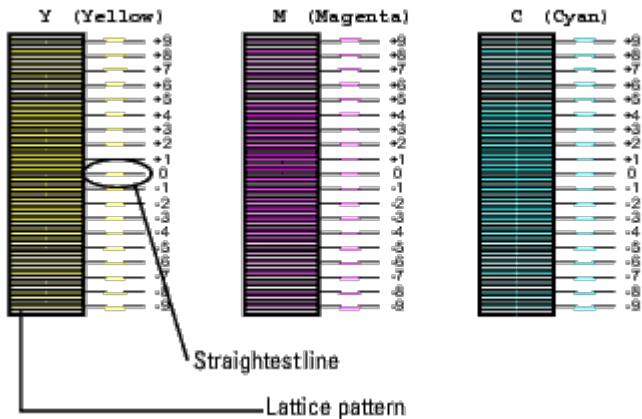











## Entering Values

### When Using the Operator Panel

Using the operator panel, enter the values that you found in the color registration chart to make adjustments.

1. Press **Menu** button.
2. Press ▼ button until **Admin Menu** appears, and then press ✓ (**Set**) button.
3. Press ▼ button until **Maintenance** appears, and then press ✓ (**Set**) button.

4. Press  button until `Color Reg Adj` appears, and then press  **(Set)** button.
5. Press  button until `Enter Number` appears, and then press  **(Set)** button.  
The cursor is located at the first digit of the `Enter Number`.
6. Press  or  button until you reach the value (for example, +3) displayed on the chart.
7. Press  button once and move the cursor to the next value.
8. Repeat steps 6 and 7 to enter all of the digits of the `Enter Number`, and then press  **(Set)** button.
9. Press  button until `Color Regi Chart` appears, and then press  **(Set)** button.  
The color registration chart is printed with the new values.
10. Color registration adjustment is complete when the straightest **Y** (Yellow), **M** (Magenta), and **C** (Cyan) lines are next to the **O** line.

## When Using the Tool Box

Using the Tool Box, enter the values that you found in the color registration chart to make adjustments.

1. Click **start® All Programs® Dell Printers® Dell 3130cn Color Laser Printer® Tool Box**.

The **Select Printer** dialog box opens.

2. Click **Dell 3130cn Color Laser PCL 6** listed in **Printer Name**, and then click **OK**.

The **Tool Box** opens.

3. Click the **Printer Maintenance** tab.
4. Select **Registration Adjustment** from the list at the left side of the page.

The **Registration Adjustment** page is displayed.

5. Select the value with the straight line, and then click the **Apply New Settings** button.
6. Click the **Start** button next to **Color Regi Chart**.

The color registration chart is printed with the new values.

7. Adjust till all straight lines are at the value of 0. Show image of before and after adjustment will help.

 **CAUTION:** After printing the color registration chart, do not turn off the printer until the printer motor has stopped running.

 **NOTE:** If 0 is not next to the straightest lines, determine the values and adjust the printer again.

---

[Back to Contents Page](#)

## Removing Options

- [Removing the 550 Sheet Feeder](#)
- [Removing a Duplexer](#)
- [Removing a Memory](#)
- [Removing a Hard Disk](#)
- [Removing the Network Protocol Adapter](#)
- [Removing the Wireless Printer Adapter](#)

If the printer location needs to change or the printer and print media handling options need to be shipped to a new location, all print media handling options must be removed from the printer. For shipping, pack the printer and print media handling options securely to avoid damage.

---

### Removing the 550 Sheet Feeder

**⚠ CAUTION:** If you are removing an 550 sheet feeder, be sure to turn off the printer, unplug the power cable, and disconnect all cables from the back of the printer before completing these tasks.

1. Turn off the printer and unplug the power cable. Then, disconnect all cables from the back of the printer.
2. Pull the tray 1 out of the printer until it stops. Hold the tray with both hands, lift the front slightly, and remove it from the printer.

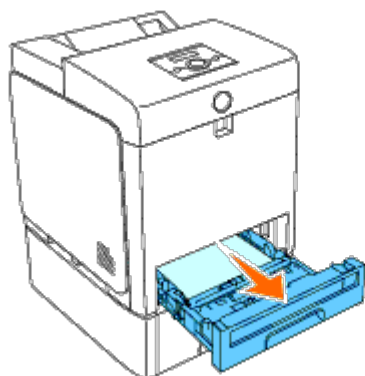

3. Remove the two screws joining the printer and the 550 sheet feeder by unscrewing them with a coin or similar object.

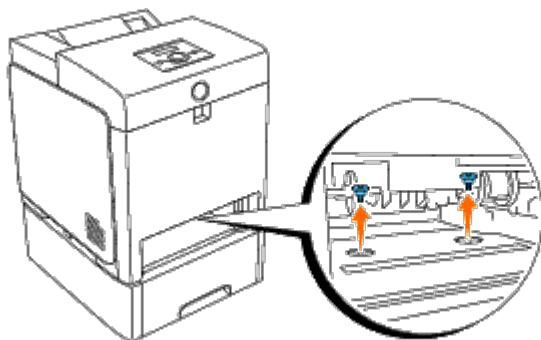

4. Gently lift the printer off the tray module, and place it on a level surface.

**⚠ CAUTION:** To lift the printer safely, lift it with two people facing the front and back. Never try to lift the printer while facing its right and left sides.

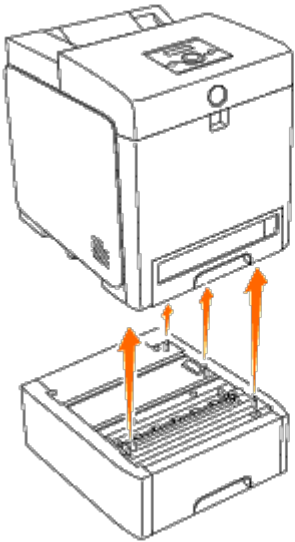

5. Insert the tray 1 into the printer, and push until it stops.

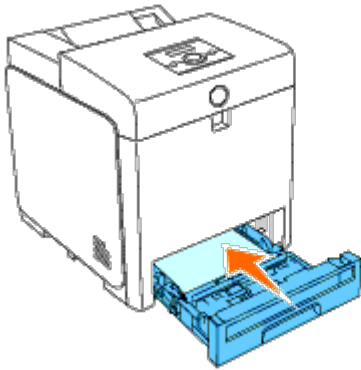

6. Reconnect all cables including the power cable into the back of the printer and turn on the printer.

---

## Removing a Duplexer

**⚠ NOTICE:** To protect the drums of the print cartridges against bright light, close the front cover within five minutes. If the front cover remains open for more than five minutes, print quality may deteriorate.

1. Ensure that the printer is turned off.
2. Push the side button and open the front cover.

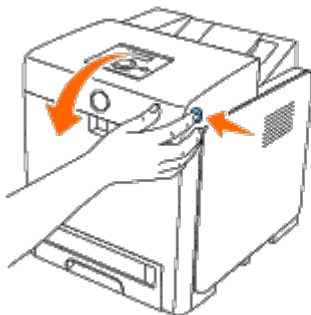

**NOTICE:** Ensure that nothing touches or scratches the surface (black-colored film) of the belt unit. Scratches, dirt, or oil from your hands on the film of the belt unit may reduce print quality.

3. Pull up on the belt release levers and rotate the belt unit up as shown in the illustration.

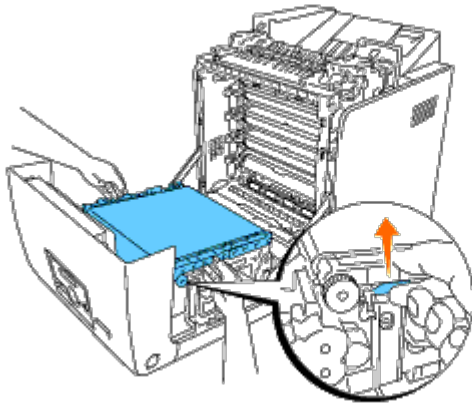

4. Hold the latch of the duplexer as shown in the following illustration and pull out the duplexer from the printer.

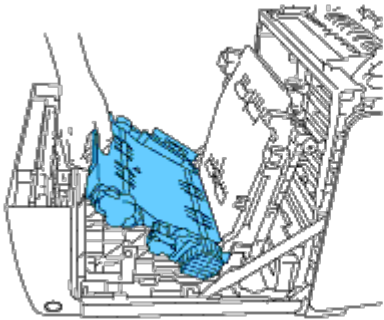

5. Close the belt unit by pulling it down.

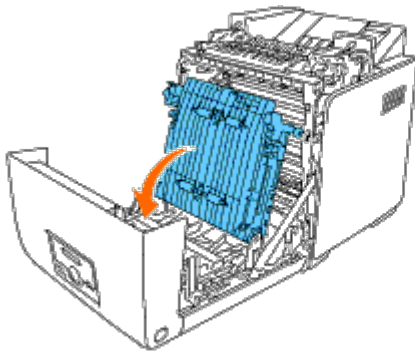

6. Close the front cover.

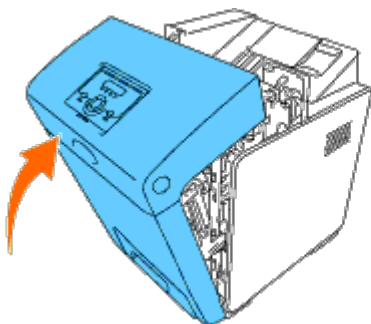



---

## Removing a Memory

1. Ensure that the printer is turned off.
2. Turn the screw on the control board cover in a counter-clockwise direction and open the cover.

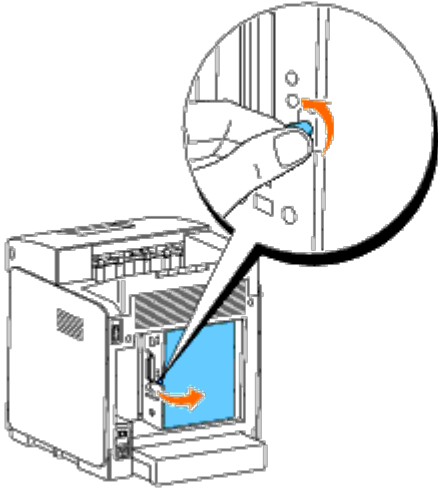

3. Pull the latches on both edges of the socket outward at the same time to raise the memory up.

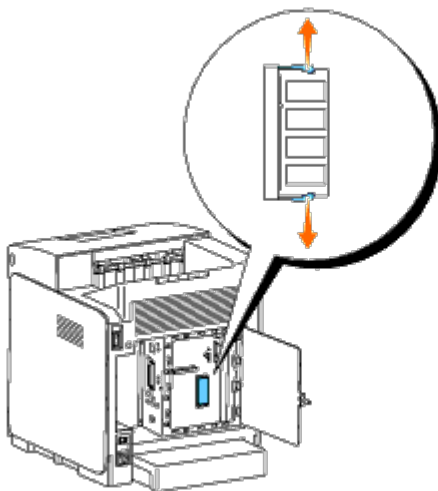

4. Hold the memory and pull it out.

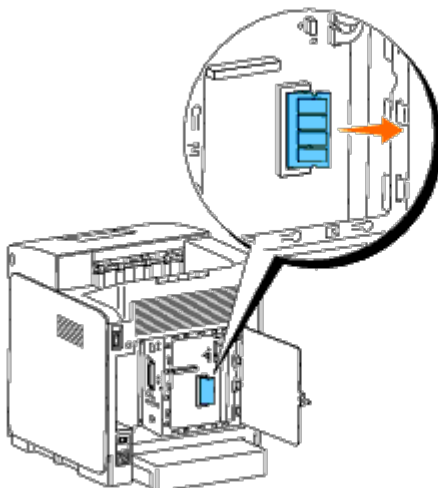

5. Close the control board cover and turn the screw clockwise.

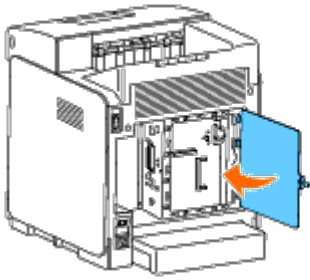

## Removing a Hard Disk

1. Ensure that the printer is turned off.
2. Turn the screw on the control board cover in a counter-clockwise direction and open the cover.

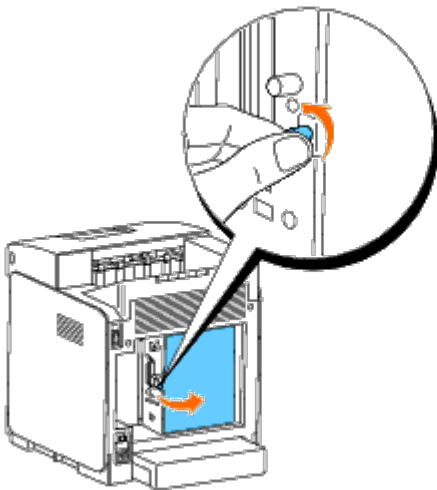

3. Remove the two screws from the hard disk on the side of the control board.

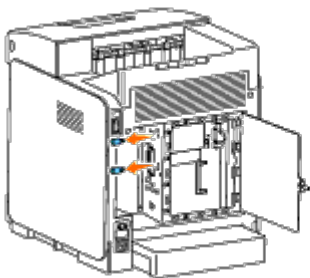

4. Hold the lower edge of the hard disk and disconnect the connector to remove it from the control board.

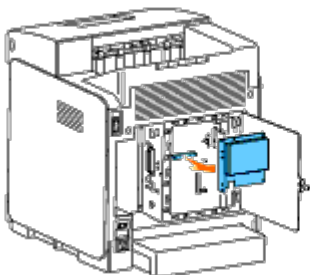

5. Close the control board cover and turn the screw clockwise.

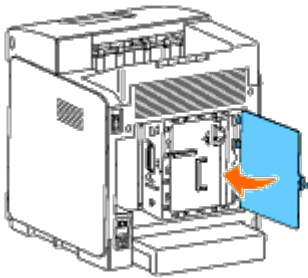

---

## Removing the Network Protocol Adapter

1. Turn off the printer and unplug the power cable. Then, disconnect all cables from the back of the printer.
2. Turn the screw on the control board cover in a counter-clockwise direction and open the cover.

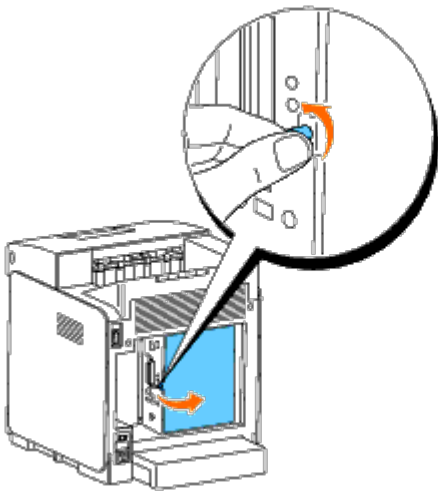

3. Remove the network protocol adapter by releasing the adapter's hooks.

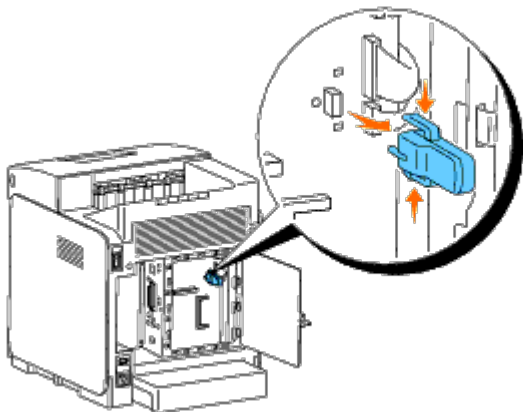

4. Close the control board cover and turn the screw clockwise.

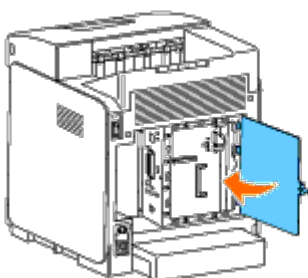

5. Reconnect all cables including the power cable into the back of the printer and turn on the printer.
-

## Removing the Wireless Printer Adapter

1. Turn off the printer and unplug the power cable. Then, disconnect all cables from the back of the printer.
2. Turn the screw on the control board cover in a counter-clockwise direction and open the cover.
3. Remove the wireless printer adapter from the printer by releasing the adapter's hook from underside of the wireless printer adapter socket as shown in the following illustration.

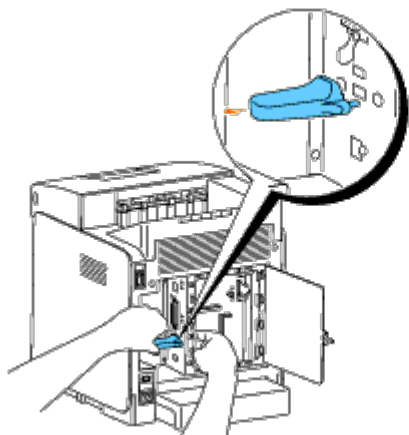

4. Insert the cap into the wireless printer adapter socket.

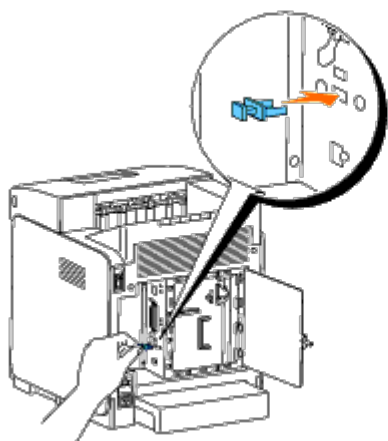

5. Close the control board cover and turn the screw clockwise.

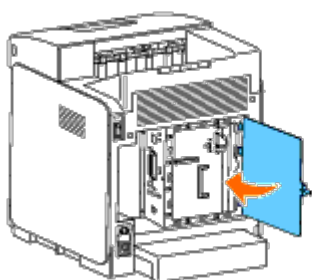

# Printer Specifications

- [OS Compatibility](#)
- [Power Supply](#)
- [Dimensions](#)
- [Memory](#)
- [Page Description Language \(PDL\)/Emulation, Operating System, and Interface](#)
- [Environment](#)
- [Cables](#)

---

## OS Compatibility

Your Dell™ 3130cn Color Laser Printer is compatible with Windows® (2000, XP, XP x64, Vista, Vista x64, 7, 7 x64, Server 2003, Server 2003 x64, Server 2008, Server 2008 x64, Server 2008 R2 x64, NT 4.0); Mac OS X (10.2.8/10.3.9/10.4.x/10.5.x); Novell® (3.12, 3.2, 4.1, 4.11, 4.2, 5, 5.1, 6, 6.5 (SP1.1 or later)) but not supported<sup>1</sup>; Linux (Turbolinux FUJI (English), SUSE Linux Enterprise Desktop 10 (English), RedHat Enterprise Linux ES 4.0/5.0 (English)) but not supported<sup>2</sup>; Unix (HP-UX 11.i (English), Solaris 9/10 (English)) but not supported.

<sup>1</sup> Dell technical phone support only supports factory-installed operating systems (Microsoft) for the first 30 days for free. See <http://www1.us.dell.com/content/products/compare.aspx/laser?c=us&cs=555&l=en&s=biz> for more details. The customer will have to purchase technical support from the manufacturer of the operating system in order to get technical assistance beyond 30 days.

<sup>2</sup> If the customer has other operating systems and has purchased Gold Technical Support (for more information on Gold Technical Support, see <http://www1.us.dell.com/content/topics/global.aspx/services/en/gts?c=us&cs=555&l=en&s=biz>), the telephone support will be a "best effort" attempt to resolve the operating system issue. If the manufacturer needs to be contacted, the customer must pay an additional fee for that support. The only time that Dell pays for the third party support is when Dell is responsible for the issue. In the case of getting the printer installed and working, this is configuration and the customer would be responsible for paying.

---

## Power Supply

<b>Rated Voltage</b>	220-240 VAC	110-127 VAC
<b>Frequency</b>	50/60 Hz	50/60 Hz
<b>Current</b>	4 A	8 A

---

## Dimensions

Height: 470 mm (18.5 in.) Width: 400 mm (15.7 in.) Depth: 504 mm (19.8 in.)

Weight (not including cartridge): 27.2 kg (59.9 lb)

---

## Memory

Base memory	256 MB
Maximum memory	1280 MB (256+1024 MB)
Connector	200 pin DDR2 SO-DIMM

DIMM Size	512 MB, 1024 MB
Speed	PC2-4200, PC2-5300

## Page Description Language (PDL)/Emulation, Operating System, and Interface

PDL/Emulations	PostScript 3, PCL 6, PCL5e	
OSes	Microsoft® Windows 7/7 x64/Server 2008 R2 x64/Vista/Vista x64/Server 2008/Server 2008 x64/XP/XP x64/Server 2003/Server 2003 x64/2000 (SP3 or later)/NT 4.0, Mac OS X (10.2.8, 10.3.9, 10.4.x, 10.5.x)	
Interfaces	Standard local:	USB, IEEE 1284
	Standard network:	10Base-T/100Base-TX Ethernet
	Optional network:	IEEE802.11b/802.11g (Wireless)

## MIB Compatibility

A Management Information Base (MIB) is a database containing information about network devices (such as adapters, bridges, routers, or computers). This information helps network administrators manage the network (analyze performance, traffic, errors, and so on). Dell™ 3130cn Color Laser Printer complies with standard industry MIB specifications, allowing the printer to be recognized and managed by various printer and network management software systems.

## Environment

### Operation

Temperature	5-32°C
Relative humidity	15-85% RH (no condensation)

### Print Quality Guarantee

Temperature	10-32°C
Relative humidity	15-85% RH (no condensation) (Temperature should be 28°C or below at 85% RH.)

### Storage

Temperature range	-20-40°C (0-104°F)
Storage humidity range	5-85% RH (no condensation)

### Altitude

Operating	Up to 3,100 m (10,000 feet)
Storage	70.9275 Kpa

---





## Chemical Emission

Concentration of ozone	0.019 mg/m <sup>3</sup>
------------------------	-------------------------

---

## Cables

Your interconnection cable must meet the following requirements:

	Connection type	Connection specifications and symbols	
1	Parallel	IEEE1284	
2	USB	USB2.0	
3	Wireless	IEEE802.11b/802.11g	
4	Ethernet	10 Base-T/100 Base-TX	

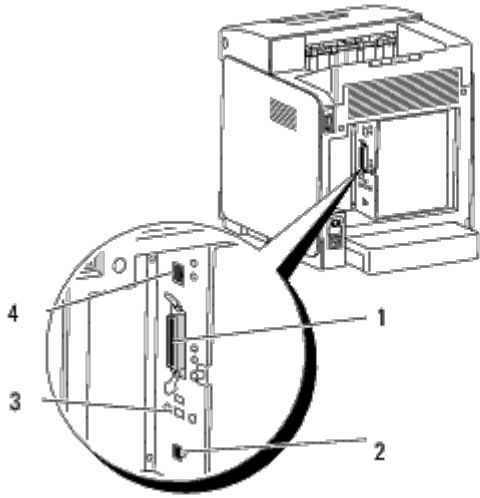

---

[Back to Contents Page](#)

# Printing With UX Filter (UNIX)

- [Overview](#)
  - [Installing the UX Filter](#)
  - [Uninstalling the UX Filter](#)
  - [Printing and Using the Utilities](#)
  - [Precautions and Limitations](#)
- 

## Overview

### The UX Filter

This section describes the features of the UX filter and its operating environment.

### Features

The UX filter is an utility software which converts files created by the UNIX workstation into a format which conforms to the PostScript language loaded in the printer. The utility provides software that converts text files, SunRaster image files (for Sun/Solaris only), TIFF image files and XWD image files into the PostScript language program. Also, it makes use of the printer features to output in the following manner.

- Input paper selection
- Double-sided printing
- Output paper selection

➡ **NOTICE:** Depending on the configurations of the printers, some may not be able to use the UX filter.

### Operating Environment

Text files, SunRaster image files (for Solaris only), TIFF image files and XWD image files received from a workstation connected to a printer by a USB cable or parallel cable (hereinafter referred to as the local workstation), or from one located on the network (hereinafter referred to as the remote workstation), can be converted into the PostScript language program and output to the printer.

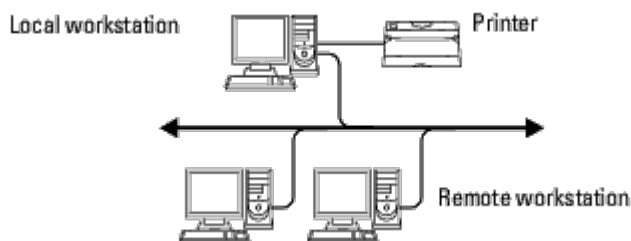

In addition, it can also be used in an environment where a printer, installed with an interface board, is connected directly to the network.



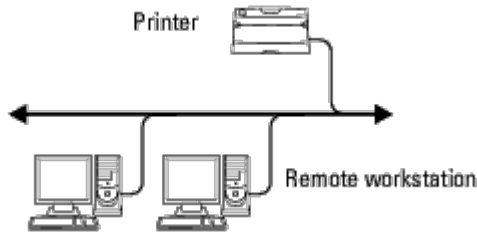

## Before Using UX Filter

Check the following items before using the UX filter.

Before setting up the workstation, set up the printer as follows.

1. Make sure the lpd port is working or not when using the network environment. If the lpd port is not working, set `LPD` to `On` on the operator panel. (Mandatory) See "[Protocol](#)" for more information.

When a parallel or USB port is to be used, make sure these are working. (Mandatory)

2. Set up IP address and subnet mask when the printer is used in the network environment. (Mandatory)
3. Make TBCPFilter function available if TBCPFilter function is installed on the printer. See "[Adobe Protocol](#)" for more information.

## Installing the UX Filter

### Before Installation

The following are required for the installation.

- Supported operating system is described in "[Page Description Language \(PDL\)/Emulation, Operating System, and Interface](#)."

Disk capacity: 20 MB of free disk space required, including temporary working space for installation.

- Log on as a root account to perform the operation here. If you have no root privilege, contact your system administrator.
- Output printer must be registered in the workstation before using UX filter. (HP-UX)  
Use `sam` command for registration of output printer.  
For more information, see the HP-UX related manual.

### Files Added by the Installation

The following files will be added when the UX filter is installed.

#### Solaris

Directory	File name	Contents
/usr/local/dellbin3130	txt2ps2	Text conversion utility
	sunras2ps2	SunRaster conversion utility
	tiff2ps2	TIFF conversion utility
	xwd2ps2	XWD conversion utility

	dellpsif	Input filter
/usr/lib/lp/postscript	dellposttxt3130cn	Symbolic link file to call txt2ps2
	dellpostps3130cn	Symbolic link file to call dellpsif
	dellbinpath3130	Directory description file for the UX filter print tool
/usr/lib/lp/model	Model interface program	Source file of the model interface program (stored as the printer name during registration)
/etc/lp/interfaces	Model interface program	Interface program for PRINTER (stored as the printer name during registration)
/etc/lp/fd	posttxt3130cn.fd	Filter description file for txt2ps2
	dell3130cn.fd	Dell3130cn filter description file for Dell 3130cn Color Laser Printer
	postio3130.fd	Dellpostio filter description file
	download3130cn.fd	Delldownload filter description file
/usr/share/man/man1	txt2ps23130cn.1	Manual page file for txt2ps2
	sunras2ps23130cn.1	Manual page file for sunras2ps2
	tiff2ps23130cn.1	Manual page file for tiff2ps2
	xwd2ps23130cn.1	Manual page file for xwd2ps2
	dellpsif3130cn.1	Manual page file for dellpsif

 **NOTE:** The directories listed are default directories.

## HP-UX

Directory	File name	Contents
/usr/local/dellbin3130	txt2ps2	Text conversion utility
	xwd2ps2	XWD conversion utility
	tiff2ps2	TIFF conversion utility
/usr/lib/lp/postscript	dellbinpath3130	Directory description file for the UX filter print tool
/usr/spool/lp/interface	Model interface program	Interface program for PRINTER (stored as the printer name during registration)
/usr/share/man/man1	txt2ps23130cn.1	Manual page file for txt2ps2
	tiff2ps23130cn.1	Manual page file for tiff2ps2
	xwd2ps23130cn.1	Manual page file for xwd2ps2

 **NOTE:** The directories listed are default directories.

## Installation Procedure Overview

This section provides information on the installation of the UX filter using the UNIX workstation.

### Solaris

1. Setup the printer and network.
2. Insert the *Drivers and Utilities* CD into the local workstation.
3. Run the installer and begin the installation.
4. Print for testing the printer.

## HP-UX

1. Setup the printer and network.
2. Insert the *Drivers and Utilities* CD into the local workstation.
3. Run the installer and begin the installation.
4. Print for testing the printer.

## Operation on Solaris

### Installation/Printer Setting

1. Insert the *Drivers and Utilities* CD in the CD-ROM drive of the local workstation.  
If CD-ROM drive is not mounted on your workstation, extract files by using another workstation that has a CD-ROM drive to transfer those files to your workstation.
2. Log on as a root account and extract the installation script from the *Drivers and Utilities* CD.

 **NOTICE:** If you have no root privilege, contact your system administrator.

```
# cd /tmp
# cp /cdrom/cdrom0/UXFILTER.tar /tmp
# tar xvf ./UXFILTER.tar
```

3. Type `./install.sh` and run the installer.

```
# ./install.sh
```

4. Select the printer model to install.

```
Printer Model ?
    1. Dell 3130cn Color Laser Printer
    2. Exit
Enter Process No (1/2)? : 1
```

5. The following menu appears. Select `<1>` and set up the local printer.

```
Solaris Installation for Dell 3130cn Color Laser Printer Type Printer
    1. Set Local Printer
    2. Set Remote Printer
Enter Process No (1/2)? : 1
```

6. Type the device name of the connection port.

```
Enter port-device-name? [/dev/ecpp0] : /dev/bpp0
```

 **NOTICE:** Specify the device file in the communication port available.

7. When `Set Remote Printer` is selected, type the host name of the server or the host name of the printer.

```
Enter server-hostname? : server
server-hostname is 'server' (y/n)[y] : y
```

➡ **NOTICE:** The host name of the server must be pre-registered with DNS, NIS, NIS+ or /etc/hosts.

8. When Set Remote Printer is selected, type the remote printer name.

```
Enter server-printer-name? : ps
server-printer-name is 'ps' (y/n)[y] : y
```

➡ **NOTICE:** Type `ps` when the printer is a network connection printer.

9. Type the printer name to be registered with the system.

```
Enter printer-name? [dell3130cn] : dell3130cn
Printer-name is 'dell3130cn' (y/n)[y] : y
```

10. Specify the directory to install the utility. To install into `/usr/local/dellbin3130`, press the `<Enter>` key. To change the directory, specify one.

```
Enter Binary directory name? [/usr/local/dellbin3130] :
```

11. If this utility has been installed earlier, the user will be prompted whether to overwrite the earlier version.

```
directory is '/usr/local/dellbin3130' (y/n)[n] : y
```

12. If the server input at step 5 the printer connected by the network, type `<y>`. If the server and the printer are connected locally, type `<n>`.

```
'dell3130cn' is network printer?:(y/n)[y] : y
```

The software installation is complete.

➡ **NOTICE:** When the printing settings are modified or changed by the Administration Tool (admintool) after the installation, printing may not work.

## Operation on HP-UX

### Installation Procedure

🔪 **NOTE:** The host name of the output printer which you want to specify in step 6 must be pre-registered with a `sam` command.

1. Insert the *Drivers and Utilities* CD into the CD-ROM drive of the local workstation.
2. Log on as a root account and extract the installation script from the *Drivers and Utilities* CD.

➡ **NOTICE:** If you have no root privilege, contact your system administrator.

```
# mount -F cdfs -o cdcase /dev/dsk/clt2d0 /cdrom
# cd /tmp
# cp /cdrom/uxfilter.tar /tmp
# tar xvf UXFILTER.tar
```

🔪 **NOTE:** `/dev/ds/clt2d0` is an example. Specify the CD-ROM device file for all workstations.

3. Type `./install.sh` and run the installer.

```
# ./install.sh
```

4. Select the printer model to install.

```
Printer Model ?  
  1. Dell 3130cn Color Laser Printer  
  2. Exit  
Enter Process No (1/2)? : 1
```

5. Specify the directory to install the utility.

```
Enter install directory name [/usr/local/dellbin3130] :  
directory is '/usr/local/dellbin3130' (y/n)[n] : y
```

6. Type the name of the output printer. Type `delllp3130cn`. Type the printer name to be registered with the system.

```
Enter output-printer-name? : delllp3130cn  
output-printer-name is 'delllp3130cn' (y/n)[y] : y
```

 **NOTE:** The registered printer name can be verified by executing `lpstat -v`.

7. Type the logical printer name. Register `dell3130cn`. Type a printer name that has not already been registered with the system.

```
Enter logical-printer-name? : dell3130cn  
Printer-name is 'dell3130cn' (y/n)[y] : y
```

8. The utility will be installed in the directory specified at step 5. Registration will be executed here so that the logical printer registered at step 7 can access the utility. As this process is automatically executed, no input is required. With the above steps, the installation is complete.

---

## Uninstalling the UX Filter

### About Uninstalling

The UX filter does not come with an uninstaller. To uninstall the UX filter, follow the following procedure.

 **NOTICE:** Log on as a root account to perform the operation here. If you have no root privilege, contact your system administrator.

### Solaris

1. Delete the printer that was registered with the system. Use the printer name created during the installation and the `lpadmin` command.

```
# lpadmin -x printername
```

2. Delete the filters registered with the system. Delete the filters registered during the installation using the `lpfilter` command.

---

```
# lpfilter -f dell3130cn -x (for Dell 3130cn Color Laser Printer)
# lpfilter -f download3130 -x
# lpfilter -f postio3130cn -x
# lpfilter -f posttxt3130cn -x
```

3. Delete the symbolic files required to call up the filter.

Delete the following files from `/usr/lib/lp/postscript`.

```
dellposttxt3130cn
dellpostps3130cn
dellbinpath3130
```

4. Delete the interface program files of *Selected printer type name* from `/usr/lib/lp/model`.

Please also delete the interface program files of *Selected printer name* from `/etc/lp/interfaces`.

5. Delete all the directories that contain the UX filters and the files in these directories created during the installation. The following directories must be deleted.

```
/usr/local/dellbin3130
```

6. Delete the filter description files. Delete the following files from `/etc/lp/fd`.

Filter description files for various printers.

```
dell3130cn.fd (for Dell 3130cn Color Laser Printer)
download3130.fd
postio3130cn.fd
posttxt3130cn.fd
```

## HP-UX

1. Delete the printer that was registered with the system. Use the `sam` command to delete the printer set up during the installation.

```
# sam
```

2. Delete all the directories that contain the UX filters and the files in these directories created during the installation. The following directories must be deleted.

```
/usr/local/dellbin3130 (directory specified during the installation)
```

---

## Printing and Using the Utilities

### Printing (Solaris)

This section provides information on printing that makes use of the filter. To print from Solaris, specify the printer registered during the installation of filters as the output destination.



**NOTICE:** To use the `lp` command, make sure the operating environment of the spooler has been set up correctly (enabled, available) using the `lpstat` command (`lpstat -p all`). For details on the options of the `lp` command and the `lpstat` command or how to make use of them, see the related manuals of Solaris.

#### Printing From Solaris

To print to the default printer:

If the printer is registered as the default printer, the name of the printer can be shortened and specified as shown in

the following example.

```
% lp filename
```

To print to other printers:

To print to a printer named *dell3130cn*, type as follows.

```
% lp -d dell3130cn filename
```

 **NOTE:** The name of the printer can be confirmed by executing `lpstat -v`.

To change the default printer temporarily for printing:

To change the default printer, set the printer name in the environment variable `LPDEST`.

To set a printer named *dell3130cn* as the default printer for printing, type as follows.

```
% setenv LPDEST dell3130cn
```

```
% lp filename
```

 **NOTE:** Using this method, a default printer can be set up for each user.

 **NOTE:** The above example describes the setup method executed when cache is used.

To select a paper tray for printing:

To select a paper tray for printing, specify the paper tray after the `-y` option of the `lp` command.

 **NOTE:** Depending on installed options, the available paper trays are different.

To select and print to a letter size paper of the printer named *dell3130cn* with landscape, specify as follows.

```
% lp -d dell3130cn -y landscape -y letter filename
```

The following options can be specified by the `lp` command.

To print text files:

 **NOTE:** It prints according to the length and width specified by the `lpadmin` command.

`-y double`

Sets printing to 2-column printing.

`-y landscape`

Rotates the image by 90° and uses the paper in the landscape orientation.

`-y size=n`

Sets the font size to *n* point.

`-y outcolumn=n`

This option converts text to single-byte text and sets printing to start from the *n*th column.

`-y outline=n`

Sets printing to start from the *n*th line.

`-y font=font`

Sets the font for printing single-byte alphanumeric characters. If the font specified is not available for the printer, the default fonts are used.

 **NOTE:** To specify a font, type the font name as-is after the `-y font=` option.

```
% lp -y font=Courier-Oblique filename
```

 **NOTE:** For information on the available fonts, see the PS Fonts List.

`-y margin=u:b:r:l`

Specifies the margin of a page in inches. The *u* (upper margin), *b* (bottom margin), *r* (right margin), and *l*

(left margin) are positive real numbers (up to two decimal points). The default is 0.

-y ps

The input file will be processed as the PostScript file. If the file does not begin with "%!", "%!" will be output to the beginning line. Whether the file contains "%!" will be ignored.

To print text/PostScript files:

-y DuplexBook

Enables the long-edge binding feature. When it is specified, the printing direction or position will be adjusted and both sides of the paper printed so that the longer edge of the pages can be bound.

-y DuplexList

Enables the short-edge binding feature. When it is specified, the printing direction or position will be adjusted and both sides of the paper printed so that the shorter edge of the pages can be bound.

-y tray-input

The paper tray-related parameters that can be specified by the lp command are as follows.

tray1

Feed paper from tray 1 (Standard 250-sheet tray).

tray2

Feed paper from tray 2 (Optional 550-sheet feeder).

a4

Feed paper from the tray loaded with A4 (210 x 297 mm).

a5

Feed paper from the tray loaded with A5 (148 x 210 mm).

b5

Feed paper from the tray loaded with B5 (182 x 257 mm).

letter

Feed paper from the tray loaded with Letter (8.5 x 11 inches).

folio

Feed paper from the tray loaded with Folio (8.5 x 13 inches).

legal

Feed paper from the tray loaded with Legal (8.5 x 14 inches).

executive

Feed paper from the tray loaded with Executive (7.25 x 10.5 inches).

monarch

Feed paper from the tray loaded with Monarch (3.875 x 7.5 inches).

com10

Feed paper from the tray loaded with Envelope #10 (4.125 x 9.5 inches).

d1

Feed paper from the tray loaded with DL (110 x 220 mm).

c5

Feed paper from the tray loaded with C5 (162 x 229 mm).

MxNmm

Feed paper from the tray loaded with MxNmm defined by users.

Possible range specified:

Width: 76.2 to 220.0 mm

Length: 127.0 to 355.6 mm

MxNin

Feed paper from the tray loaded with MxNinches defined by users.



Possible range specified:

Width: 3.00 to 8.66 inches

Length: 5.00 to 14.0 inches

If this option is not specified or the tray specified tray is not available, feed paper from the default tray.

-y toner\_save

Turns on the *save toner* mode for printing. The print result will be fainter than that of normal printing.

-y nc=*n*

Specifies the number of output copies (the value of copies must be a positive integer). If this option is not specified, 1 will be selected.

-y cl

Specifies that printing be collated. If the *copies* option is not specified, this option will be ignored.

-y ps

The input file will be processed as the PostScript file. If the file does not begin with %!, %! will be output to the beginning line. If a file contains %!, this option will be ignored.

-y msi

Specifies multipurpose feeder.

-y m=*type*

Specifies multipurpose feeder Paper Type.

Available multipurpose feeder Paper Types are as follows.

B

FinePaper/Bond/Plain Paper 2

BB

FinePaperBack/Bond/Plain Paper 2 - Side 2

P

Stationary/Plain/Plain Paper 1

PB

StationaryBack/Plain/Plain Paper 1 - Side 2

R

Recycled Paper

RB

RecycledPaperBack/ Recycled Paper - Side 2

H1

ThickPaper/Heavyweight 1/Covers 1

H1B

ThickPaperBack/Heavyweight 1/Covers 1 - Side 2

H2

ThickPaper2/Heavyweight 2/Covers 2

H2B

ThickPaper2Back/Heavyweight 2/Covers 2 - Side 2

OHP

Transparency

L

LabelPaper/Labels

C2

Coated/Coated 2/Coated Paper 2

C2B

Coated Back/Coated 2/Coated Paper 2- Side 2

C3

Coated Thick/Coated 3/Coated Paper 3

C3B

Coated Thick Back/Coated 3/Coated Paper 3- Side 2

E

Envelope

If this option is not specified, multipurpose feeder Paper Type for the printer can be used.

-y mfo=*mode*

Specifies orientation for multipurpose feeder.

Available orientations for multipurpose feeder are as follows.

1e

Landscape

1er

Landscape (Rotated)

se

Portrait

ser

Portrait (Rotated)

-y po=*n*

Specifies alternate tray.

Available alternate trays are as follows.

0

Use printer settings

1

Display message

2

Feed from multipurpose feeder

3

Use nearest size (Adjust to fit)

4

Use larger size (Adjust to fit)

5

Use nearest size (No zoom)

6

Use larger size (No zoom)

-y st=*mode*

Specifies feed separators from.

Available feed separators from the following.

auto

AutoTray/Auto

1

1stTray/Tray 1 (Standard 250-sheet tray)

2

2ndTray/Tray 2 (Optional 550-sheet feeder)

off

Off

-y sp

Specifies printed separators.

-y sb

Specifies Skip Blank Pages.

-y cm=*mode*

Specifies output color.

Available output colors are as follows.

c

Color (CMYK)

k

Black

-y pr=*mode*

Specifies print mode.

Available print modes are as follows.

hs

High speed

hq

High quality

sf

Super fine

-y cc=*mode*

Specifies image types.

Available image types are as follows.

0

Off

1

Photo

2

sRGB

3

Standard/ Normal

4

Presentation

This option is available only for color printing and when entry data is RGB data.

-y gc=*mode*

Specifies RGB gamma correction.

Available RGB gamma corrections are as follows.

1.0

1.0

1.4

1.4

1.8

1.8

2.2

2.2

2.6

2.6

off

Off

This option is available only for color printing and when entry data is RGB data.

-y *sc=mode*

Specifies screen.

Available screens are as follows.

0

Fineness

1

Gradation

2

Auto

3

For Transparency

-y *gg=mode*

Specifies gray guaranteed.

Available gray guaranteed modes are as follows.

on

On

off

Off

This option is available only for color printing.

-y *ct*

Specifies color transformation.

This option is available only for color printing.

-y *br=mode*

Specifies brightness adjustment.

Available brightness adjustment option values are as follows.

+5

Bright 5

+4

Bright 4

+3

Bright 3

+2

Bright 2

+1

Bright 1

+0

Normal

- 1  
Dark 1
- 2  
Dark 2
- 3  
Dark 3
- 4  
Dark 4
- 5  
Dark 5

`-y rgbc=mode`

Specifies RGB color correction.

Available RGB color corrections are as follows.

- 10  
Perceptual
- 11  
Saturation
- 12  
RelativeC
- 13  
AbsoluteC

This option is available only for color printing and when entry data is RGB data.

`-y rgbpr=mode`

Specifies RGB input profile.

Available RGB input profile option value are as follows.

- 0  
sRGB
- 1  
AdobeRGB

This option is available only for color printing and when entry data is RGB data.

`-y rgbtb=mode`

Specifies RGB color temperature.

Available RGB color temperature option value are as follows.

- 5000  
5000K
- 6000  
6000K
- 9300  
9300K

This option is available only for color printing and when entry data is RGB data.

`-y cb=cyan-low:cyan-middle:cyan-high:magenta-low:magenta-middle:magenta-high:yellow-low:yellow-middle:yellow-high:black-low:black-middle:black-high`

Specifies adjustment value for color balance of each color/density.

Available adjustment values are as follows.

- +3  
Dark 3
- +2  
Dark 2
- +1  
Dark 1
- 0  
Normal

-1  
Light 1

-2  
Light 2

-3  
Light 3

-Cb  
Option value must be specified in the following order:

Cyan low density, Cyan medium density, Cyan high density, Magenta low density, Magenta medium density, Magenta high density, Yellow low density, Yellow medium density, Yellow high density, Black low density, Black medium density, Black high density

If no value is specified, it is treated as "0"(Normal).

For example, if you want to specify "Light 2" for Cyan medium density, "Dark 3" for Yellow high density, and "Dark 2" for Black low density, it can be specified using either of the following:

-Cb=0: -2:0:0:0:0:0:0: +3: +2:0:0

-Cb=: -2:::~::~:~::~:~::~:~::~:~::~: +3: +2::

-y -hld=*PrintType:UserID:Password:DocumentName*

Secure Print

*PrintType*

store

Secure Print/Store Print

proof

Proof Print

*UserID*

Up to eight single-byte characters from 0x20 to 0x7E, except 0x20 " " (blank) and 0x3A":" (colon).

*Password*

Up to 12 single-byte characters from 0x30 to 0x39 (numeric characters).

*DocumentName*

Up to 12 single-byte characters from 0x20 to 0x7E, except 0x20 " " (blank) and 0x3A":" (colon).

Secure Print

-y hld=store:*UserID:Password:DocumentName*

-y hld=store:*UserID:Password:*

Store Print

-y hld=store:*UserID::DocumentName*

-y hld=store:*UserID::*

Proof Print

-y hld=proof:*UserID::DocumentName*

-y hld=proof:*UserID::*

-y -Jown= *jobownername: Password Authentication Setting*

Specifies job owner name and password for authentication.

- When only job owner name is specified (-Jown=*jobownername:*) (no password specified), authentication password is treated as not specified.
- When only password is specified (-Jown=*:password*) (no job owner name specified), login user name is used as job owner name. Entered password is used as authentication password.
- When neither of job owner name nor password is specified (-Jown=*:*), login user name is used as job owner name, and authentication password is treated as not specified.
- When a job owner name exceeds allowable character length, the extra characters are ignored.

- o When an unacceptable character is specified for job owner name, "Unknown User" is used as job owner name.

 **NOTE:** Characters acceptable for job owner name are alphanumeric characters and symbols, except for space and colon.

 **NOTE:** Up to 32 characters are acceptable for job owner name.

- o When an unacceptable character is specified for password, or when a specified password is not within the range of the allowable character length, the authentication password is treated as not specified.

 **NOTE:** Acceptable password length is between 4 and 12 characters.

Incomplete form of -Jown option is treated as no authentication setting being made. In such case, if authentication setting is made with the environmental variable, it is used as setting information.

## Printing (HP-UX)

This section provides information on printing from the registered logical printer during the installation.

### Printing From HP-UX

To print to the default printer:

If the printer is registered as the default printer, the name of the printer can be shortened and specified as shown in the following example.

```
% lp filename
```

To print to other printers:

To print to a printer named `dell13130cn`, type as follows.

```
% lp -d dell13130cn filename
```

To change the default printer temporarily for printing:

To change the default printer, set the printer name in the environment variable `PRINTER`.

To set a printer named `dell13130cn` as the default printer for printing, type as follows.

```
% setenv PRINTER dell13130cn
% lp filename
```

To print with added options:

To print with the options, specify the option of the `lp` command using `-o` as follows.

The available options are the same as `txt2ps2/tiff2ps/xwd2ps2`.

Depending on installed options, the available paper trays are different.

```
%lp -d dell13130cn -o r -o ILT filename
```

To print using file format:

To print text files:

```
% lp -d dell13130cn filename
```

To print XWD files:

```
% lp -d dell13130cn -o XWD filename
```

To print TIFF format files:

```
% lp -d dell13130cn -o TIF filename
```

To print PostScript files:

```
% lp -d dell13130cn filename
```

To print PostScript files as text files:

```
% lp -d dell13130cn -o TX filename
```

However, for PostScript files with options set up, such as paper selection, etc., when the same option is specified, it will be ignored.

## Authentication Printing

This section provides information on how to specify the user name used for authentication printing in the environment variable.

### Specifying the User Name

#### To specify the User Name for Authentication Printing:

You can specify a unique user name in the environment variable as follows.

```
% setenv JOWN3130U " jobownername"
```

You can specify the login name as the user name as follows.

```
% setenv JOWN3130U ""
```

 **NOTE:** Up to 32 characters are acceptable for the user name. When a user name exceeds allowable character length, the extra characters are ignored.

 **NOTE:** If you specify the filter option when authentication printing is already specified, the filter option has the higher priority over authentication printing.

### Specifying the Password

#### To Specify the Password for Authentication Printing:

If you need to specify the password in authentication printing, you can specify the password in the environment variable as follows.

```
% setenv JOWN3130P "password"
```

If you do not specify the password inexplicitly, type as follows.

```
% setenv JOWN3130P ""
```

 **NOTE:** Acceptable password length is between 4 and 12 characters. When an unacceptable character is specified for password, or when a specified password is not within the range of the allowable character length, the extra characters are ignored.

 **NOTE:** If you specify the filter option when authentication printing is already specified, the filter option has the higher priority over authentication printing.

 **NOTE:** If you only specify the password without specifying the user name in the environment variable, the login name is assumed as the user name.



**NOTICE:** If you enter the password in the login file for automatically allocating the environment variable when you log in, you are recommended to specify the appropriate access privilege that prevents unauthorized users from reading the login file.

## txt2ps2 (Solaris/HP-UX)

### Format

```
/usr/local/dellbin3130/txt2ps2 [-d] [-D] [-Itray-input] [-t] [-2] [-r] [-F] [-llines] [-wcolumns]
[-outcolumns] [-Loutlines] [-en] [-ssize] [-E] [-ffont] [-Nc=copies] [-cl] [-ps] [-
mg=up:bottom:right:left] [-Hd=position:format:page] [-Hffont] [-MSI] [-M=type] [-Mfo=mode] [-Pon] [-
St=mode] [-Sp] [-Sb] [-Cm=mode] [-Pr=mode] [-Cc=mode] [-Gc=mode] [-Sc=mode] [-Gg=mode] [-Cb=cyan-
low:cyan-middle:cyanhigh:magenta- low:magenta-middle:magenta-high:yellow-low:yellow-middle:yellow
high:black-low:black-middle:black-high] [-Hld=PrintType:UserID:Password:DocumentName] [-Jown=
jobownername:password] [filename...]
```

### Function

Reads text, converts it to the PostScript language program, and writes to standard output. If the filename is not specified, the standard input will be taken as the command input.

By typing character strings in the environmental variable `TXT2PS2OPTION`, the input of option at the command line can be omitted.

At the environmental variable `TXT2PS2OPTION` and the command line, if no option is specified, the printer will output in 10-point font size in the portrait orientation.

At the environmental variable `TXT2PS2OPTION` and the command line, if the same option is specified, the one specified at the command line will prevail.

`txt2ps2` outputs the PostScript language program that adjusts the line/column according to the paper size. For this reason, the user need not be aware of the paper size. If there is an option to specify the line/column, automatic line feed according to the paper size will not be executed. Printing will be output according to the line/column specified.

`txt2ps2` interprets the following control codes. Other control codes/undefined codes will be converted to octal numbers and output as-is.

LF	Line feed
FF	Form feed (modifiable by option)
TAB	8-column tab stop (modifiable by option)
BS	Backspace 1 character

### Option

-d

Enables the short-edge binding feature. When it is specified, the printing direction or position will be adjusted and both sides of the paper printed so that the shorter edge of the pages can be bound. This option is available only when optional duplexer is installed on the printer.

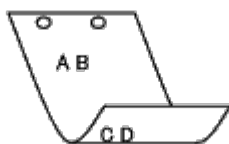

-D

Enables the long-edge binding feature. When it is specified, the printing direction or position will be adjusted and both sides of the paper printed so that the longer edge of the pages can be bound. This option is available only

when optional duplexer is installed on the printer.

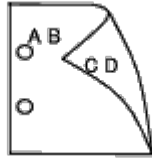

*- I tray-input*

Specifies the paper tray. A paper tray can be selected by directly specifying a tray or by specifying a paper size.

When a paper size is specified, the tray loaded with paper of the specified size will be found and selected automatically.

The parameters for selecting a paper tray are as follows.

1

Feed paper from tray 1 (Standard 250-sheet tray).

2

Feed paper from tray 2 (Optional 550-sheet feeder).

A4

Feed paper from the tray loaded with A4 (210 x 297 mm).

A5

Feed paper from the tray loaded with A5 (148 x 210 mm).

B5

Feed paper from the tray loaded with B5 (182 x 257 mm).

LT

Feed paper from the tray loaded with Letter (8.5 x 11 inches).

FL

Feed paper from the tray loaded with Folio (8.5 x 13 inches).

LG

Feed paper from the tray loaded with Legal (8.5 x 14 inches).

EX

Feed paper from the tray loaded with Executive (7.25 x 10.5 inches).

MO

Feed paper from the tray loaded with Monarch (3.875 x 7.5 inches).

COM10

Feed paper from the tray loaded with Envelope #10 (4.125 x 9.5 inches).

DL

Feed paper from the tray loaded with DL (110 x 220 mm).

C5

Feed paper from the tray loaded with C5 (162 x 229 mm).

PC

Feed paper from the tray loaded with Japanese Postcard (100 x 148 mm).

Y2

Feed paper from the tray loaded with Youkei 2 (114 x 162 mm).

Y3

Feed paper from the tray loaded with Youkei 3 (98 x 148 mm).

Y4

Feed paper from the tray loaded with Youkei 4 (105 x 235 mm).

YT3

Feed paper from the tray loaded with Youchoukei 3 (120 x 235 mm).

*MxNmm*

Feed paper from the tray loaded with MxNmm defined by users.  
Possible range specified:  
Width: 76.2 to 220.0 mm  
Length: 127.0 to 355.6 mm

*MxNin*

Feed paper from the tray loaded with MxNinches defined by users.  
Possible range specified:  
Width: 3.00 to 8.66 inches  
Length: 5.00 to 14.0 inches

If this option is not specified or the tray specified is not available, feed paper from the default tray.

-t

Turns on the *save toner* mode for printing. The print result will be fainter than that of normal printing. In some cases, this option will be ignored.

-2

Sets printing to 2-column printing.

-r

Rotates the image by 90° and uses the paper in the landscape orientation.

-F

Ignores the form feed code (FF).

-l*lines*

Specifies the number of lines per page.

-w*columns*

Specifies the number of columns per line.

-o*outcolumns*

Converts print data to single-byte text and sets printing to start from outcolumns.

-l*outlines*

Prints text from the outline columns.

-e*n*

Expands horizontal tabs to *n* columns (space). The default is 8.

-s*size*

Specifies the font size as point size. The default is 10.

-E

This function turns on the image enhancement function. For models without the image enhancement mechanism, this option will be ignored.

-f*font*

Sets the font.



**NOTE:** The available fonts are limited to the font in the printer. For more information, see "[Understanding Fonts.](#)"

-Nc=*copies*

Specifies the number of output copies (the value of copies must be a positive integer).

-c1

Specifies that printing be collated. If the copies option is not specified, this option will be ignored.

-ps

The input file will be processed as the PostScript file. If the file does not begin with `%!` , `%!`  will be output to the beginning line. If a file contains `%!` , it will be processed in the same way as `dellpsif`.

`-mg=up:bottom:right:left`

Specifies the margin of a page in inches. The upper margin, bottom margin, right margin, and left margin are positive real numbers (up to two decimal points). The default is 0.

`-mg=0:0:0:3`

Sets the left margin to 3 inches.

`-mg=3:3:0:5`

Sets the upper margin to 3 inches; bottom margin, 3 inches; and left margin, 5 inches. If the margin is 0, it can be omitted.

`-mg=:::3`

Sets the left margin to 3 inches.

`-Hd=position:format:page`

Specifies the position that the user information of the header or footer is output at. *position* specifies output position. But this option is available only for converting text files.

`ul`

Output on the upper left corner of the paper.

`ur`

Output on the upper right corner of the paper.

`dl`

Output on the lower left corner of the paper.

`dr`

Output on the lower right corner of the paper.

*format* specifies the contents and the order to output. This option is omissible. If this option is omitted, `uh` is specified as the default value.

`u`

User name

`h`

Host name

`t`

Date and time

If the output contents are specified as `tuh`, it is output as follows.  
Date and Time User: *username* Host: *hostname*

*page* specifies the page to output. This option is omissible.

`f`

Output the top page only.  
(default in case of PostScriptfiles conversion)

`a`

Output all pages.  
(default in case of Text files conversion)

Specify these options as follows.

In the case that convert text file, output the host name following the user name on the upper right corner of the paper, output all pages.  
(User name, Host name, all page output are default)

`-Hd=ur`  
`-Hd=ur:uh`  
`-Hd=ur:uh:a`

In the case that convert PostScript file, output the host name following the date and time on the lower left corner of

the paper, output all pages (a option value is necessary because *output the top page only* is default when PostScript file is converted.)

`-Hd=dl:th:a`



**NOTICE:** If the paper size is not specified, it outputs the header and footer at the position of A4 size by default. If the paper size is specified by `lp` command, the output position of the header or footer is not changed from the position of the paper size specified by `txt2ps2`. Specify the paper size at the same time when the header and footer option is used. Sometimes all pages are not printed despite specifying all page output when PostScript file conversion is specified. In such cases, specify *output the top page only*. By using TZ environmental variable, specify time zone (GMT etc.).

`-Hfont`

Specify the font to print the header and footer. European fonts the same as half size alphanumeric fonts can be specified. Helvetica is specified as default. If the wrong font is specified, the default European font of the printer can be used. If the header/footer output option is specified, the font specification for the header/footer is ignored.

`-MSI`

Specifies multipurpose feeder.

`-M=type`

Specifies multipurpose feeder Paper Type.  
Available multipurpose feeder Paper Types are as follows.

B

FinePaper/Bond/Plain Paper 2

BB

FinePaperBack/Bond/Plain Paper 2- Side 2

P

Stationary/Plain/Plain Paper 1

PB

StationaryBack/Plain/Plain Paper 1 - Side 2

R

Recycled Paper

RB

RecycledPaperBack/ Recycled Paper - Side 2

H1

ThickPaper/Heavyweight 1/Covers 1

H1B

ThickPaperBack/Heavyweight 1/Covers 1 - Side 2

H2

ThickPaper2/Heavyweight 2/Covers 2

H2B

ThickPaper2Back/Heavyweight 2/Covers 2 - Side 2

OHP

Transparency

L

LabelPaper/Labels

C2

Coated/Coated 2/Coated Paper 2

C2B

Coated Back/Coated 2/Coated Paper 2- Side 2

C3

Coated Thick/Coated 3/Coated Paper 3

C3B

Coated Thick Back/Coated 3/Coated Paper 3- Side 2

JC

JapaneseCoatingPaper/Japanese Coated/Japanese Coated Paper

JCB

JapaneseCoatingPaperBack/Japanese Coated/Japanese Coated Paper - Side 2

PC

JapanesePostcard/Japanese Postcard

PCB

JapanesePostcardBack/Japanese Postcard/Japanese Postcard - Side 2

E

Envelope

If this option is not specified, multipurpose feeder Paper Type of the printer can be used.

`-Mfo=mode`

Specifies orientation for multipurpose feeder.  
Available orientations for multipurpose feeder are as follows.

le

Landscape

ler

Landscape (Rotated)

se

Portrait

ser

Portrait (Rotated)

`-Pon`

Specifies alternate tray.  
Available alternate trays are as follows.

0

Use printer settings

1

Display message

2

Feed from multipurpose feeder

3

Use nearest size (Adjust to fit)

4

Use larger size (Adjust to fit)

5

Use nearest size (No zoom)

6

Use larger size (No zoom)

`-St=mode`

Specifies feed separators from.

Available feed separators froms are as follows.

`auto`

AutoTray/Auto

1

1stTray/Tray 1 (Standard 250-sheet tray)

2

2ndTray/Tray 2 (Optional 550-sheet feeder)

`off`

Off

`-Sp`

Specifies printed separators.  
Available only when the paper tray for separators is specified.

`-Sb`

Specifies Skip Blank Pages.

`-Cm=mode`

Specifies output color.  
Available output colors are as follows.

`c`

Color (CMYK)

`k`

Black

`-Pr=mode`

Specifies print mode.  
Available print modes are as follows.

`hs`

High Speed

`hq`

High Quality

`-Cc=mode`

Specifies RGB Color Correction.  
Available RGB Color Corrections are as follows.

0

Off

1

Photo

2

sRGB

3

Standard/ Normal

4

Presentation

This option is available only for color printing and when entry data is RGB data.

`-Gc=mode`

Specifies RGB gamma correction.  
Available RGB gamma corrections are as follows.

1.0

1.0

1.4

1.4

1.8

1.8

2.2

2.2

2.6

2.6

off

Off

This option is available only for color printing and when entry data is RGB data.

*-Sc=mode*

Specifies screen.  
Available screens are as follows.

0

Fineness

1

Standard

2

Auto

3

Gradation

*-Gg=mode*

Specifies gray guaranteed.  
Available gray guaranteed options are as follows.

on

On

off

Off

This option is available only for color printing.

*-Ct*

Specifies color transformation.  
This option is available only for color printing.

*-Br=mode*

Specifies brightness adjustment.  
Available brightness adjustment option values are as follows.

+5

Bright 5

+4

Bright 4

+3

Bright 3



+2  
Bright 2  
+1  
Bright 1  
+0  
Normal  
-1  
Dark 1  
-2  
Dark 2  
-3  
Dark 3  
-4  
Dark 4  
-5  
Dark 5

`-RGBc=mode`

Specifies RGB color correction.

Available RGB color corrections are as follows.

10  
Perceptual  
11  
Saturation  
12  
RelativeC  
13  
AbsoluteC

This option is available only for color printing and when entry data is RGB data.

`-RGBPr=mode`

Specifies RGB input profile.

Available RGB input profile option value are as follows.

0  
sRGB  
1  
AdobeRGB

This option is available only for color printing and when entry data is RGB data.

`-RGBTp=mode`

Specifies RGB color temperature.

Available RGB color temperature option value are as follows.

5000  
5000K  
6000  
6000K

9300

### 9300K

This option is available only for color printing and when entry data is RGB data.

`-Cb=cyan-low:cyan-middle:cyan-high:magenta-low:magenta-middle:magenta-high:yellow-low:yellow-middle:yellow-high:black-low:black-middle:black-high`

Specifies adjustment value for color balance of each color/density.

Available adjustment values are as follows.

- +3  
Dark 3
- +2  
Dark 2
- +1  
Dark 1
- 0  
Normal
- 1  
Light 1
- 2  
Light 2
- 3  
Light 3
- Cb

Option value must be specified in the following order:

Cyan low density, Cyan medium density, Cyan high density, Magenta low density, Magenta medium density, Magenta high density, Yellow low density, Yellow medium density, Yellow high density, Black low density, Black medium density, Black high density

If no value is specified, it is treated as "0"(Normal).

For example, if you want to specify "Light 2" for Cyan medium density, "Dark 3" for Yellow high density, and "Dark 2" for Black low density, it can be specified using either of the following:

`-Cb=0:-2:0:0:0:0:0:0:+3:+2:0:0`

`-Cb=-2::::::::+3:+2::`

`-Hld=PrintType:UserID:Password:DocumentName`

#### Secure Print

##### *PrintType*

store

Secure Print/Store Print

proof

Proof Print

##### *UserID*

Up to eight single-byte characters from 0x20 to 0x7E, except 0x20 " " (blank) and 0x3A ":" (colon).

##### *Password*

Up to 12 single-byte characters from 0x30 to 0x39 (numeric characters).

##### *DocumentName*

Up to 12 single-byte characters from 0x20 to 0x7E, except 0x20 " " (blank) and 0x3A ":" (colon).

#### Secure Print

```
-Hld=store:UserID:Password:DocumentName
```

```
-Hld=store:UserID:Password:
```

#### Store Print

```
-Hld=store:UserID: :DocumentName
```

```
-Hld=store:UserID: :
```

#### Proof Print

```
-Hld=proof:UserID: :DocumentName
```

```
-Hld=proof:UserID: :
```



**NOTICE:** Make sure you specify Secure Print only when you directly print data to a printer. Secure Print may not be available if you specify it when data need to be printed through another server or data need to be handled by another program such as PostScript files. Collate is automatically specified when you specify Proof Print.

```
-Jown= jobownername: Password Authentication Setting
```

Specifies job owner name and password for authentication.

- When only job owner name is specified (-Jown=jobownername:) (no password specified), authentication password is treated as not specified.
- When only password is specified (-Jown=:password) (no job owner name specified), login user name is used as job owner name. Entered password is used as authentication password.
- When neither of job owner name nor password is specified (-Jown=:), login user name is used as job owner name, and authentication password is treated as not specified.
- When a job owner name exceeds allowable character length, the extra characters are ignored.
- When an unacceptable character is specified for job owner name, "Unknown User" is used as job owner name.



**NOTE:** Characters acceptable for job owner name are alphanumeric characters and symbols, except for space and colon.



**NOTE:** Up to 32 characters are acceptable for job owner name.

- When an unacceptable character is specified for password, or when a specified password is not within the range of the allowable character length, the authentication password is treated as not specified.



**NOTE:** Acceptable password length is between 4 and 12 characters.

Incomplete form of -Jown option is treated as no authentication setting being made. In such case, if authentication setting is made with the environmental variable, it is used as setting information.

## Example

To convert the program list of the `file.txt` file into the PostScript language program that sets the paper to the landscape orientation and prints in the 2-up mode, type as follows:

```
% txt2ps2 -r -2 file.txt | lp
```

To convert `file.txt` to the PostScript language program and output it to the `file.ps` file, type as follows:

```
% txt2ps2 file.txt > file.ps  
% lp file.ps
```

To convert the output result of the command into the PostScript language program using `txt2ps2` and print it to the printer, type as follows:

```
% ls -alF | txt2ps2 | lp
```

## Environmental Variable

### TXT2PS2OPTION

Optional settings based on the environmental variable. To output in the 2-up mode, 8 points and the landscape orientation, type as follows:

```
% setenv TXT2PS2OPTION "-2 -s8 -r"
```

To use the same options as those of the dellpsif filter specified by printcap, type as follows:

```
% setenv TXT2PS2OPTION "<dellpsif>"
```

## File

/usr/local/dellbin3130/.dellpsdefault3130

This is the default command option setting file for individual users.

## Important

- When the same option is specified twice, the later setting will prevail. As TXT2PS2OPTION is analyzed before the option of the command line, it is possible to temporarily modify the options already set in TXT2PS2OPTION by typing at the command line.
- The comment description (%page:m n) of the page number cannot be output to the PostScript program file which is output by the default option of txt2ps2. Thus, when the output of txt2ps2 is to be taken as the output of another application (psrev of TRANSCRIPT, etc.), add the page number description by inserting the line command (`-l lines`).
- If a BS code is found at the beginning of a line, the print position of the next character will be located at the left of the beginning of the line.
- When there are multiple tab codes in one line, the tab position may be off as a result of automatic line feed. In such case, use the `-I` or `-w` option.
- The number of columns specified by the `-w` option is not the actual number of printed characters. The actual number of single-byte characters to be printed is derived by deducting the output column position (outcolumns) specified by the `o` option from the number of columns specified by the `-w` option.

The `-mg` option cannot be specified when `-w`, `-l`, `-o`, and `-L` option are specified.

The start positions of margin of the margin command (`-mg=u:b:r:l`) are not set against the edge of the paper. The margins are set against the printable area of the paper allowed by the printer.

Use the `-ps` option only when a PostScript file that contains no `%!`  at the beginning of the file is used as the PostScript file. If a normal text file is input, it will not function correctly.

- In HP-UX, txt2ps2 considers files written by PostScript that contain `%!`  at the beginning of the file as the PostScript files. To print PostScript files as text files, specify the `TX` option. With this option, PostScript files will be processed as text files.

## sunras2ps2 (Solaris)

### Format

```
/usr/local/dellbin3130/sunras2ps2 [-d] [-D] [-Itray-input] [-t] [-r] [-n] [-l=left,bottom] [-s=width,height] [-S=width] [-E] [-Nc=copies] [-Cl] [-Hd=position:format] [-Hffont] [-MSI] [-M=type] [-Mfo=mode] [-Pon] [-St=mode] [-Sp] [-Sb] [-Cm=mode] [-Pr=mode] [-Cc=mode] [-Gc=mode] [-Sc=mode] [-Gg=mode] [-Ct] [-Br=mode] [-RGbc=mode] [-RGBPr=mode] [-RGBTp=mode] [-Cb=cyan-low:cyan-middle:cyan-high:magenta-low:magenta-middle:magenta-high:yellow-low;yellow-middle:yellow-high:black-low:black-middle:black-high] [-Hld=PrintType:UserID:Password:DocumentName] [-Jown=jobownername:password] [filename...]
```

## Function

Reads SunRaster data, converts it to the PostScript language program and writes to standard output. If the filename is not specified, the standard input will be taken as the command input. SunRaster files with a pixel depth of 1, 8, 24, and 32 bits can be specified.

sunran2ps2 takes filename as having been created in 72dpi and calculates the output size. Thus, to convert SunRaster files created in other resolutions, specify the size option (`-s`, `-s`) explicitly.

## Option

`-d`

Enables the short-edge binding feature. When it is specified, the printing direction or position will be adjusted and both sides of the paper printed so that the shorter edge of the pages can be bound. This option is available only when the optional duplexer is installed on the printer.

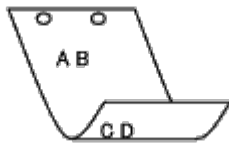

`-D`

Enables the long-edge binding feature. When it is specified, the printing direction or position will be adjusted and both sides of the paper printed so that the longer edge of the pages can be bound. This option is available only when the optional duplexer is installed on the printer.

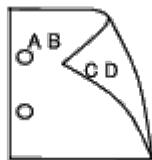

`-Itray-input`

Specifies the paper tray.

A paper tray can be selected by directly specifying a tray or by specifying a paper size.

When a paper size is specified, the tray loaded with paper of the specified size will be found and selected automatically.

The parameters for selecting a paper tray are as follows.

1

Feed paper from tray 1 (Standard 250-sheet tray).

2

Feed paper from tray 2 (Optional 550-sheet feeder).

A4

Feed paper from the tray loaded with A4 (210 x 297 mm).

A5

Feed paper from the tray loaded with A5 (148 x 210 mm).

B5

Feed paper from the tray loaded with B5 (182 x 257 mm).

LT

Feed paper from the tray loaded with Letter (8.5 x 11 inches).

FL

Feed paper from the tray loaded with Folio (8.5 x 13 inches).

LG

Feed paper from the tray loaded with Legal (8.5 x 14 inches).

EX

Feed paper from the tray loaded with Executive (7.25 x 10.5 inches).

MO

Feed paper from the tray loaded with Monarch (3.875 x 7.5 inches).

COM10

Feed paper from the tray loaded with Envelope #10 (4.125 x 9.5 inches).

DL

Feed paper from the tray loaded with DL (110 x 220 mm).

C5

Feed paper from the tray loaded with C5 (162 x 229 mm).

PC

Feed paper from the tray loaded with Japanese Postcard (100 x 148 mm).

Y2

Feed paper from the tray loaded with Youkei 2 (114 x 162 mm).

Y3

Feed paper from the tray loaded with Youkei 3 (98 x 148 mm).

Y4

Feed paper from the tray loaded with Youkei 4 (105 x 235 mm).

YT3

Feed paper from the tray loaded with Youchoukei 3 (120 x 235 mm).

MxNmm

Feed paper from the tray loaded with MxNmm defined by users.

Possible range specified:  
Width: 76.2 to 220.0 mm  
Length: 127.0 to 355.6 mm

MxNin

Feed paper from the tray loaded with MxN inches defined by users.

Possible range specified:  
Width: 3.00 to 8.66 inches  
Length: 5.00 to 14.0 inches

If this option is not specified or the tray specified is not available, feed paper from the default tray.

-t

Turns on the *save toner* mode for printing. The print result will be fainter than that of normal printing. In some cases, this option will be ignored.

-r

Rotates the image by 90° and uses the paper in the landscape orientation.

-n

Disables the addition of the showpage. It is used when files converted to the PostScript language program are merged with files created with other applications.

-l=*left, bottom*

Specifies the print position. Printing will be executed from the left and bottom of the page. The default is 0.25 inches for both left and bottom.

-s=*width, height*

Specifies the output size. Printing will be executed with the width and height in inches.

-S=*width*

Sets the width of the output size in inches. The height will be calculated automatically according to the width.

-E

This function turns on the image enhancement function. In some cases, this option will be ignored.

-Nc=*copies*

Specifies the number of output copies (the value of copies must be a positive integer).

-Cl

Specifies that printing be collated. If the copies option is not specified, this option will be ignored.

-Hd=*position:format*

Specifies the position to be output the user information as the header or footer. *position* specifies output position. But this option is available only for converting text files.

ul

Output on the upper left corner of the paper.

ur

Output on the upper right corner of the paper.

dl

Output on the lower left corner of the paper.

dr

Output on the lower right corner of the paper.

*format* specifies the contents and the order to output. This option is omissible.

If this option is omitted, *uh* is specified as the default value.

u

User name

h

Host name

t

Date and time

If the output contents are specified as *tuh*, it is output as follows.

Date and Time User: *username* Host: *hostname*.

Specify these options as follows.

In the case that convert text file, output the host name following the user name on the upper right corner of the paper, output all pages.

(User name, Host name, all page output are default)

-Hd=*ur*

-Hd=*ur:uh*

-Hf*font*

Specify the font to print the header and footer. European fonts the same as half size alphanumeric fonts can be specified. Helvetica is specified as default.

If the wrong font is specified, default European font of the printer can be used.

If header/footer output option is specified, the font specification of header/footer is ignored.

-MSI

Specifies multipurpose feeder.

-M=*type*

Specifies multipurpose feeder Paper Type.

Available multipurpose feeder Paper Types are as follows.

B

FinePaper/Bond/Plain Paper 2

BB

FinePaperBack/Bond/Plain Paper 2 - Side 2

P

Stationary/Plain/Plain Paper 1

PB

StationaryBack/Plain/Plain Paper 1 - Side 2

R

Recycled Paper

RB

RecycledPaperBack/ Recycled Paper - Side 2

H1

ThickPaper/Heavyweight 1/Covers 1

H1B

ThickPaperBack/Heavyweight 1/Covers 1 - Side 2

H2

ThickPaper2/Heavyweight 2/Covers 2

H2B

ThickPaper2Back/Heavyweight 2/Covers 2 - Side 2

OHP

Transparency

L

LabelPaper/Labels

C2

Coated/Coated 2/Coated Paper 2

C2B

Coated Back/Coated 2/Coated Paper 2- Side 2

C3

Coated Thick/Coated 3/Coated Paper 3

C3B

Coated Thick Back/Coated 3/Coated Paper 3- Side 2

JC

JapaneseCoatingPaper/Japanese Coated/Japanese Coated Paper

JCB

JapaneseCoatingPaperBack/Japanese Coated/Japanese Coated Paper - Side 2

PC

JapanesePostcard/Japanese Postcard

PCB

JapanesePostcardBack/Japanese Postcard/Japanese Postcard - Side 2

E

Envelope

If this option is not specified, multipurpose feeder Paper Type of the printer can be used.



Specifies orientation for multipurpose feeder.  
Available orientations for multipurpose feeder are as follows.

- le Landscape
- ler Landscape (Rotated)
- se Portrait
- ser Portrait (Rotated)

-Pon

Specifies alternate tray.  
Available alternate trays are as follows.

- 0 Use printer settings
- 1 Display message
- 2 Feed from multipurpose feeder
- 3 Use nearest size (Adjust to fit)
- 4 Use larger size (Adjust to fit)
- 5 Use nearest size (No zoom)
- 6 Use larger size (No zoom)

-St=mode

Specifies feed separators from.  
Available feed separators from the following.

- auto AutoTray/Auto
- 1 1stTray/Tray 1 (Standard 250-sheet tray)
- 2 2ndTray/Tray 2 (Optional 550-sheet feeder)
- off Off

-Sp

Specifies printed separators.  
Available only when the paper tray for separators is specified.

-Sb

Specifies Skip Blank Pages.

-Cm=mode

Specifies output color.

Available output colors are as follows.

c

Color (CMYK)

k

Black

*-Pr=mode*

Specifies print mode.

Available print modes are as follows.

hs

High speed

hq

High quality

sf

Super fine

*-Cc=mode*

Specifies image types.

Available image types are as follows.

0

Off

1

Photo

2

sRGB

3

Standard/ Normal

4

Presentation

This option is available only for color printing and when entry data is RGB data.

*-Gc=mode*

Specifies RGB gamma correction.

Available RGB gamma corrections are as follows.

1.0

1.0

1.4

1.4

1.8

1.8

2.2

2.2

2.6

2.6

off

Off

This option is available only for color printing and when entry data is RGB data.

-Sc=mode

Specifies screen.  
Available screens are as follows.

0

Fineness

1

Gradation

2

Auto

3

For Transparency

-Gg=mode

Specifies gray guaranteed.  
Available gray guaranteed options are as follows.

on

On

off

Off

This option is available only for color printing.

-Ct

Specifies color transformation.

This option is available only for color printing.

-Br=mode

Specifies brightness adjustment.

Available brightness adjustment option value are as follows.

+5

Bright 5

+4

Bright 4

+3

Bright 3

+2

Bright 2

+1

Bright 1

+0

Normal

-1

Dark 1

-2

Dark 2

-3

Dark 3

-4

Dark 4

-5

Dark 5

`-RGBc=mode`

Specifies RGB color correction.

Available RGB color corrections are as follows.

10

Perceptual

11

Saturation

12

RelativeC

13

AbsoluteC

This option is available only for color printing and when entry data is RGB data.

`-RGBPr=mode`

Specifies RGB input profile.

Available RGB input profile option value are as follows.

0

sRGB

1

AdobeRGB

This option is available only for color printing and when entry data is RGB data.

`-RGBTp=mode`

Specifies RGB color temperature.

Available RGB color temperature option value are as follows.

5000

5000K

6000

6000K

9300

9300K

This option is available only for color printing and when entry data is RGB data.

`-Cb=cyan-low:cyan-middle:cyan-high:magenta-low:magenta-middle:magenta-high:yellow-low:yellow-middle:yellow-high:black-low:black-middle:black-high`

Specifies adjustment value for color balance of each color/density.

Available adjustment values are as follows.

+3

Dark 3

+2

Dark 2

+1

Dark 1

0  
Normal  
-1  
Light 1  
-2  
Light 2  
-3  
Light 3  
-Cb

Option value must be specified in the following order:

Cyan low density, Cyan medium density, Cyan high density, Magenta low density, Magenta medium density, Magenta high density, Yellow low density, Yellow medium density, Yellow high density, Black low density, Black medium density, Black high density

If no value is specified, it is treated as "0"(Normal).

For example, if you want to specify "Light 2" for Cyan medium density, "Dark 3" for Yellow high density, and "Dark 2" for Black low density, it can be specified using either of the following:

-Cb=0: -2:0:0:0:0:0:0: +3: +2:0:0

-Cb=: -2:::~::~+3: +2::

-Hld=PrintType:UserID:Password:DocumentName

Secure Print

*PrintType*

store

Secure Print/Store Print

proof

Proof Print

*UserID*

Up to eight single-byte characters from 0x20 to 0x7E, except 0x20 " " (blank) and 0x3A ":" (colon).

*Password*

Up to 12 single-byte characters from 0x30 to 0x39 (numeric characters).

*DocumentName*

Up to 12 single-byte characters from 0x20 to 0x7E, except 0x20 " " (blank) and 0x3A ":" (colon).

Secure Print

-Hld=store:UserID:Password:DocumentName

-Hld=store:UserID:Password:

Store Print

-Hld=store:UserID::DocumentName

-Hld=store:UserID::

Proof Print

-Hld=proof:UserID::DocumentName

-Hld=proof:UserID::





**NOTICE:** Make sure you specify Secure Print only when you directly print data to a printer. Secure Print may not be available if you specify it when data need to be printed through another server or data need to be handled by another program such as PostScript files. Collate is automatically specified when you specify Proof Print.

-Jown= jobownername: Password Authentication Setting

Specifies job owner name and password for authentication.

- o When only job owner name is specified (-Jown=jobownername:) (no password specified), authentication password is treated as not specified.
- o When only password is specified (-Jown=:password) (no job owner name specified), login user name is used as job owner name. Entered password is used as authentication password.
- o When neither of job owner name nor password is specified (-Jown=:), login user name is used as job owner name, and authentication password is treated as not specified.
- o When a job owner name exceeds allowable character length, the extra characters are ignored.
- o When an unacceptable character is specified for job owner name, "Unknown User" is used as job owner name.

 **NOTE:** Characters acceptable for job owner name are alphanumeric characters and symbols, except for space and colon.

 **NOTE:** Up to 32 characters are acceptable for job owner name.

- o When an unacceptable character is specified for password, or when a specified password is not within the range of the allowable character length, the authentication password is treated as not specified.

 **NOTE:** Acceptable password length is between 4 and 12 characters.

Incomplete form of -Jown option is treated as no authentication setting being made. In such case, if authentication setting is made with the environmental variable, it is used as setting information.

## Example

To output the displayed screen image to a file using the snapshot command and convert the file into the PostScript language program using the `sunras2ps2` command, type as follows.

```
% sunras2ps2 file.rs > file.ps
```

To output the displayed screen image to a file using the snapshot command, convert the file into the PostScript language program using the `sunras2ps2` command and output it to a printer, type as follows.

```
% sunras2ps2 file.rs | lp
```

## Important

- When `-s` and `-S` are specified at the same time or when the same option is specified twice, the later setting will prevail.
- If the output size option (`-s`, `-S`) is not specified, scaling will be executed taking one pixel of the raster data as one pixel of the printer.
- If the print position option specifies a point beyond the printable area of the printer, data beyond the printable area will not be printed.

## tiff2ps2 (Solaris/HP-UX)

### Format

```
/usr/local/dellbin3130/tiff2ps2 [-d] [-D] [-Itray-input] [-t] [-r] [-n] [-l=left,bottom] [-s=width,height] [-S=width] [-E] [-Nc=copies] [-Cl] [-Hd=position:format] [-Hffont] [-MSI] [-M=type] [-Mfo=mode] [-Pon] [-St=mode] [-Sp] [-Sb] [-Cm=mode] [-Pr=mode] [-Cc=mode] [-Gc=mode] [-Sc=mode] [-Gg=mode] [-Ct] [-Br=mode] [-RGBC=mode] [-RGBPr=mode] [-RGBTp=mode] [-Cb=cyan-low:cyan-middle:cyanhigh:magenta-low:magenta-middle:magenta-high:yellow-low;yellow-middle:yellow high:black-low:black-middle:black-high] [-Hld=PrintType:UserID:Password:DocumentName] [-Jown=jobownername:password] [filename...]
```

## Function

Reads TIFF data, converts it to the PostScript language program and writes to standard output. If the filename is not specified, the standard input will be taken as the command input. TIFF files with a pixel depth of 1, 4, 8, 24, and 32 bits can be specified.

There are four types of supported compression formats.

Huffman compression (CCITT Group 3 transformed Huffman run length encoding)

Fax-CCITT3 compression (facsimile-compatible CCITT Group 3)

PackBits compression

Non-compression

Even in the above compression format, the TIFF file that has multiple images in one file is not supported.

tiff2ps2 takes filename as having been created in 72 dpi and calculates the output size. Thus, to convert TIFF files created in other resolutions, specify the size option (`-s`, `-s`) explicitly for conversion.

## Option

`-d`

Enables the short-edge binding feature. When it is specified, the printing direction or position will be adjusted and both sides of the paper printed so that the shorter edge of the pages can be bound. This option is available only when the optional duplexer is installed on the printer.

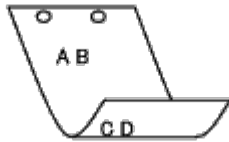

`-D`

Enables the long-edge binding feature. When it is specified, the printing direction or position will be adjusted and both sides of the paper printed so that the longer edge of the pages can be bound. This option is available only when the optional duplexer is installed on the printer.

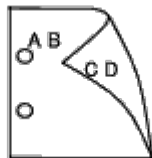

`-Itray-input`

Specifies the paper tray.

A paper tray can be selected by directly specifying a tray or by specifying a paper size.

When a paper size is specified, the tray loaded with paper of the specified size will be found and selected automatically.

The parameters for selecting a paper tray are as follows.

1

Feed paper from tray 1 (Standard 250-sheet tray).

2

Feed paper from tray 2 (Optional 550-sheet feeder).

A4

Feed paper from the tray loaded with A4 (210 x 297 mm).

A5

Feed paper from the tray loaded with A5 (148 x 210 mm).

B5

Feed paper from the tray loaded with B5 (182 x 257 mm).

LT

Feed paper from the tray loaded with Letter (8.5 x 11 inches).

FL

Feed paper from the tray loaded with Folio (8.5 x 13 inches).

LG

Feed paper from the tray loaded with Legal (8.5 x 14 inches).

EX

Feed paper from the tray loaded with Executive (7.25 x 10.5 inches).

MO

Feed paper from the tray loaded with Monarch (3.875 x 7.5 inches).

COM10

Feed paper from the tray loaded with Envelope #10 (4.125 x 9.5 inches).

DL

Feed paper from the tray loaded with DL (110 x 220 mm).

C5

Feed paper from the tray loaded with C5 (162 x 229 mm).

PC

Feed paper from the tray loaded with Japanese Postcard (100 x 148 mm).

Y2

Feed paper from the tray loaded with Youkei 2 (114 x 162 mm).

Y3

Feed paper from the tray loaded with Youkei 3 (98 x 148 mm).

Y4

Feed paper from the tray loaded with Youkei 4 (105 x 235 mm).

YT3

Feed paper from the tray loaded with Youchoukei 3 (120 x 235 mm).

MxNmm

Feed paper from the tray loaded with MxNmm defined by users

Possible range specified:

Width: 76.2 to 220.0 mm

Length: 127.0 to 355.6 mm

MxNin

Feed paper from the tray loaded with MxNinches defined by users

Possible range specified:

Width: 3.00 to 8.66 inches

Length: 5.00 to 14.0 inches

If this option is not specified or the tray specified is not available, feed paper from the default tray.

-t

Turns on the *save toner* mode for printing. The print result will be fainter than that of normal printing. In some cases, this option will be ignored.

-r

Rotates the image by 90° and uses the paper in the landscape orientation.

-n

Disables the addition of the showpage. It is used when files converted to the PostScript language program are merged with files created with other applications.



`-l=left,bottom`

Specifies the print position. Printing will be executed from the left and bottom of the page. The default is 0.25 inches for both left and bottom.

`-s=width,height`

Specifies the output size. Printing will be executed with the width and height in inches.

`-S=width`

Sets the width of the output size in inches. The height will be calculated automatically according to the width.

`-E`

This function turns on the image enhancement function. In some cases, this option will be ignored.

`-Nc=copies`

Specifies the number of output copies (the value of copies must be a positive integer).

`-C1`

Specifies that printing be collated. If the copies option is not specified, this option will be ignored.

`-Hd=position:format`

Specifies the position to be output the user information as the header or footer.  
*position* specifies output position. But this option is available only for converting text files.

`ul`

Output on the upper left corner of the paper.

`ur`

Output on the upper right corner of the paper.

`dl`

Output on the lower left corner of the paper.

`dr`

Output on the lower right corner of the paper.

*format* specifies the contents and the order to output. This option is omissible.  
If this option is omitted, `uh` is specified as the default value.

`u`

User name

`h`

Host name

`t`

Date and time

If the output contents are specified as `tuh`, it is output as follows.  
Date and Time User: *username* Host: *hostname*.

Specify these options as follows.

In the case that convert text file, output the host name following the user name on the upper right corner of the paper, output all pages.

(User name, Host name, all page output are default)

`-Hd=ur`

`-Hd=ur:uh`

`-Hf font`

Specify the font to print header and footer. European fonts the same as half size alphanumeric fonts can be specified. Helvetica is specified as default.

If the wrong font is specified, default European font of the printer can be used.

If header/footer output option is specified, the font specification of header/footer is ignored.

`-MSI`

Specifies multipurpose feeder.

`-M=type`

Specifies multipurpose feeder Paper Type.  
Available multipurpose feeder Paper Types are as follows.

B

FinePaper/Bond/Plain Paper 2

BB

FinePaperBack/Bond/Plain Paper 2 - Side 2

P

Stationary/Plain/Plain Paper 1

PB

StationaryBack/Plain/Plain Paper 1 - Side 2

R

Recycled Paper

RB

RecycledPaperBack/ Recycled Paper - Side 2

H1

ThickPaper/Heavyweight 1/Covers 1

H1B

ThickPaperBack/Heavyweight 1/Covers 1 - Side 2

H2

ThickPaper2/Heavyweight 2/Covers 2

H2B

ThickPaper2Back/Heavyweight 2/Covers 2 - Side 2

OHP

Transparency

L

LabelPaper/Labels

C2

Coated/Coated 2/Coated Paper 2

C2B

Coated Back/Coated 2/Coated Paper 2- Side 2

C3

Coated Thick/Coated 3/Coated Paper 3

C3B

Coated Thick Back/Coated 3/Coated Paper 3- Side 2

JC

JapaneseCoatingPaper/Japanese Coated/Japanese Coated Paper

JCB

JapaneseCoatingPaperBack/Japanese Coated/Japanese Coated Paper - Side 2

PC

JapanesePostcard/Japanese Postcard

PCB

JapanesePostcardBack/Japanese Postcard/Japanese Postcard - Side 2

E

Envelope

If this option is not specified, multipurpose feeder Paper Type of the printer can be used.

`-Mfo=mode`

Specifies orientation for multipurpose feeder.  
Available orientations for multipurpose feeder are as follows.

- le  
Landscape
- ler  
Landscape (Rotated)
- se  
Portrait
- ser  
Portrait (Rotated)

`-Pon`

Specifies alternate tray.  
Available alternate trays are follows.

- 0  
Use printer settings
- 1  
Display message
- 2  
Feed from multipurpose feeder
- 3  
Use nearest size (Adjust to fit)
- 4  
Use larger size (Adjust to fit)
- 5  
Use nearest size (No zoom)
- 6  
Use larger size (No zoom)

`-St=mode`

Specifies feed separators from.  
Available feed separators from the following.

- auto  
AutoTray/Auto
- 1  
1stTray/Tray 1 (Standard 250-sheet tray)
- 2  
2ndTray/Tray 2 (Optional 550-sheet feeder)
- off  
Off

`-Sp`

Specifies printed separators.  
Available only when the paper tray for separators is specified.

`-Sb`

Specifies Skip Blank Pages.

-Cm=mode

Specifies output color.  
Available output colors are as follows.

c  
Color (CMYK)

k  
Black

-Pr=mode

Specifies print mode.  
Available print modes are as follows.

hs  
High speed

hq  
High quality

sf  
Super fine

-Cc=mode

Specifies image types.  
Available image types are as follows.

0  
Off

1  
Photo

2  
sRGB

3  
Standard/ Normal

4  
Presentation

This option is available only for color printing and when entry data is RGB data.

-Gc=mode

Specifies RGB gamma correction.  
Available RGB gamma corrections are as follows.

1.0  
1.0

1.4  
1.4

1.8  
1.8

2.2  
2.2

2.6  
2.6

off  
Off

This option is available only for color printing and when entry data is RGB data.

*-Sc=mode*

Specifies screen.

Available screens are as follows.

0

Fineness

1

Gradation

2

Auto

3

For Transparency

*-Gg=mode*

Specifies gray guaranteed.

Available gray guaranteed options are as follows.

on

On

off

Off

This option is available only for color printing.

*-Ct*

Specifies color transformation.

This option is available only for color printing.

*-Br=mode*

Specifies brightness adjustment.

Available brightness adjustment option values are as follows.

+5

Bright 5

+4

Bright 4

+3

Bright 3

+2

Bright 2

+1

Bright 1

+0

Normal

-1

Dark 1

-2

Dark 2

-3

Dark 3

-4

Dark 4

-5

Dark 5

`-RGBc=mode`

Specifies RGB color correction.

Available RGB color corrections are as follows.

10

Perceptual

11

Saturation

12

RelativeC

13

AbsoluteC

This option is available only for color printing and when entry data is RGB data.

`-RGBPr=mode`

Specifies RGB input profile.

Available RGB input profile option value are as follows.

0

sRGB

1

AdobeRGB

This option is available only for color printing and when entry data is RGB data.

`-RGBTp=mode`

Specifies RGB color temperature.

Available RGB color temperature option value are as follows.

5000

5000K

6000

6000K

9300

9300K

This option is available only for color printing and when entry data is RGB data.

`-Cb=cyan-low:cyan-middle:cyan-high:magenta-low:magenta-middle:magenta-high:yellow-low:yellow-middle:yellow-high:black-low:black-middle:black-high`

Specifies adjustment value for color balance of each color/density.

Available adjustment values are as follows.

+3

Dark 3

+2

Dark 2

+1



Specifies job owner name and password for authentication.

- When only job owner name is specified (-Jown=jobownername:) (no password specified), authentication password is treated as not specified.
- When only password is specified (-Jown=:password) (no job owner name specified), login user name is used as job owner name. Entered password is used as authentication password.
- When neither of job owner name nor password is specified (-Jown=:), login user name is used as job owner name, and authentication password is treated as not specified.
- When a job owner name exceeds allowable character length, the extra characters are ignored.
- When an unacceptable character is specified for job owner name, "Unknown User" is used as job owner name.

 **NOTE:** Characters acceptable for job owner name are alphanumeric characters and symbols, except for space and colon.

 **NOTE:** Up to 32 characters are acceptable for job owner name.

- When an unacceptable character is specified for password, or when a specified password is not within the range of the allowable character length, the authentication password is treated as not specified.

 **NOTE:** Acceptable password length is between 4 and 12 characters.

Incomplete form of -Jown option is treated as no authentication setting being made. In such case, if authentication setting is made with the environmental variable, it is used as setting information.

## Example

To convert the TIFF image into the PostScript language program and output it to a file, type as follows.

```
% tiff2ps2 file.tiff > file1.ps
```

To output the TIFF image to a printer, type as follows.

```
% tiff2ps2 file.tiff | lp
```

## Important

- When -s and -s are specified at the same time or when the same option is specified twice, the later setting will prevail.
- When the output size option (-s, -s) is not specified, scaling will be executed taking one pixel of the TIFF data as one pixel of the printer.
- If the print position option (-l *left bottom*) specifies a point beyond the printable area of the printer, data beyond the printable area will not be printed.

## xwd2ps2 (Solaris/HP-UX)

### Format

```
/usr/local/dellbin3130/xwd2ps2 [-d] [-D] [-Itray-input] [-t] [-r] [-n] [-l=left,bottom] [-s=width,height] [-S=width] [-E] [-Nc=copies] [-Cl] [-Hd=position:format] [-Hffont] [-MSI] [-M=type] [-Mfo=mode] [-Pon] [-St=mode] [-Sp] [-Sb] [-Cm=mode] [-Pr=mode] [-Cc=mode] [-Gc=mode] [-Sc=mode] [-Gg=mode] [-Ct] [-Br=mode] [-RGBc=mode] [-RGBPr=mode] [-RGBTp=mode] [-Cb=cyan-low:cyan-middle:cyan-high:magenta-low:magenta-middle:magenta-high:yellow-low:yellow-middle:yellow-high:black-low:black-middle:black-high] [-Hld=PrintType:UserID:Password:DocumentName] [-Jown=jobownername:password] [filename...]
```



## Function

Reads XWD data, converts it to the PostScript language program and writes to standard output. If the filename is not specified, the standard input will be taken as the command input. XWD files with a pixel depth of 1, 4, 8, 24, and 32 bits can be specified.

There are three types of supported compression formats.

The visual class is Static Gray and the pixel is 1 bit.

The visual class is Pseudo Color and the pixel is 4 bits or 8 bit. The image format is Zpixmap.

The visual class is True Color and the pixel is 24 bits or 32 bit. The image format is Zpixmap.

xwd2ps2 takes filename as having been created in 72dpi and calculates the output size. Thus, to convert XWD files created in other resolutions, specify the size option (*-s*, *-s*) explicitly for conversion.

## Option

-d

Enables the short-edge binding feature. When it is specified, the printing direction or position will be adjusted and both sides of the paper printed so that the shorter edge of the pages can be bound. This option is available only when the optional duplexer is installed on the printer.

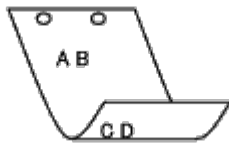

-D

Enables the long-edge binding feature. When it is specified, the printing direction or position will be adjusted and both sides of the paper printed so that the longer edge of the pages can be bound. This option is available only when the optional duplexer is installed on the printer.

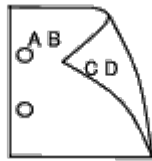

-Itray-input

Specifies the paper tray.

A paper tray can be selected by directly specifying a tray or by specifying a paper size.

When a paper size is specified, the tray loaded with paper of the specified size will be found and selected automatically.

The parameters for selecting a paper tray are as follows.

1

Feed paper from tray 1 (Standard 250-sheet tray).

2

Feed paper from tray 2 (Optional 550-sheet feeder).

A4

Feed paper from the tray loaded with A4 (210 x 297 mm).

A5

Feed paper from the tray loaded with A5 (148 x 210 mm).

B5

Feed paper from the tray loaded with B5 (182 x 257 mm).

LT

Feed paper from the tray loaded with Letter (8.5 x 11 inches).

FL

Feed paper from the tray loaded with Folio (8.5 x 13 inches).

LG

Feed paper from the tray loaded with Legal (8.5 x 14 inches).

EX

Feed paper from the tray loaded with Executive (7.25 x 10.5 inches).

MO

Feed paper from the tray loaded with Monarch (3.875 x 7.5 inches).

COM10

Feed paper from the tray loaded with Envelope #10 (4.125 x 9.5 inches).

DL

Feed paper from the tray loaded with DL (110 x 220 mm).

C5

Feed paper from the tray loaded with C5 (162 x 229 mm).

PC

Feed paper from the tray loaded with Japanese Postcard (100 x 148 mm).

Y2

Feed paper from the tray loaded with Youkei 2 (114 x 162 mm).

Y3

Feed paper from the tray loaded with Youkei 3 (98 x 148 mm).

Y4

Feed paper from the tray loaded with Youkei 4 (105 x 235 mm).

YT3

Feed paper from the tray loaded with Youchoukei 3 (120 x 235 mm).

MxNmm

Feed paper from the tray loaded with MxN mm defined by users.

Possible range specified:

Width: 76.2 to 220.0 mm

Length: 127.0 to 355.6 mm

MxNin

Feed paper from the tray loaded with MxNinches defined by users

Possible range specified:

Width: 3.00 to 8.66 inches

Length: 5.00 to 14.0 inches

If this option is not specified or the tray specified is not available, feed paper from the default tray.

-t

Turns on the *save toner* mode for printing. The print result will be fainter than that of normal printing. In some cases, this option will be ignored.

-r

Rotates the image by 90° and uses the paper in the landscape orientation

-n

Disables the addition of the showpage. It is used when files converted to the PostScript language program are merged with files created with other applications.

-l=*left, bottom*

Specifies the print position. Printing will be executed from the left and bottom of the page. The default is 0.25 inches for both left and bottom.

-s=*width, height*

Specifies the output size. Printing will be executed with the width and height in inches.

`-S=width`

Sets the width of the output size in inches. The height will be calculated automatically according to the width.

`-E`

This function turns on the image enhancement function. In some cases, this option will be ignored.

`-Nc=copies`

Specifies the number of output copies (the value of copies must be a positive integer).

`-c1`

Specifies that printing be collated. If the copies option is not specified, this option will be ignored.

`-Hd=position:format`

Specifies the position to be output the user information as the header or footer.  
*position* specifies output position. But this option is available only for converting text files.

ul

Output on the upper left corner of the paper.

ur

Output on the upper right corner of the paper.

dl

Output on the lower left corner of the paper.

dr

Output on the lower right corner of the paper.

*format* specifies the contents and the order to output. This option is omissible.  
If this option is omitted, *uh* is specified as the default value.

u

User name

h

Host name

t

Date and time

If the output contents are specified as *tuh*, it is output as follows.  
Date and Time User: *username* Host: *hostname*.

`-Hf font`

Specify the font to print header and footer. European fonts the same as half size alphanumeric fonts can be specified. Helvetica is specified as default.

If the wrong font is specified, default European font of the printer can be used.

If header/footer output option is specified, the font specification of header/footer is ignored.

`-MSI`

Specifies multipurpose feeder.

`-M=type`

Specifies multipurpose feeder Paper Type.  
Available multipurpose feeder Paper Types are as follows.

B

FinePaper/Bond/Plain Paper 2

BB

FinePaperBack/Bond/Plain Paper 2 - Side 2

P

Stationary/Plain/Plain Paper 1

PB

StationaryBack/Plain/Plain Paper 1 - Side 2

R

Recycled Paper

RB

RecycledPaperBack/ Recycled Paper - Side 2

H1

ThickPaper/Heavyweight 1/Covers 1

H1B

ThickPaperBack/Heavyweight 1/Covers 1 - Side 2

H2

ThickPaper2/Heavyweight 2/Covers 2

H2B

ThickPaper2Back/Heavyweight 2/Covers 2 - Side 2

OHP

Transparency

L

LabelPaper/Labels

C2

Coated/Coated 2/Coated Paper 2

C2B

Coated Back/Coated 2/Coated Paper 2- Side 2

C3

Coated Thick/Coated 3/Coated Paper 3

C3B

Coated Thick Back/Coated 3/Coated Paper 3- Side 2

JC

JapaneseCoatingPaper/Japanese Coated/Japanese Coated Paper

JCB

JapaneseCoatingPaperBack/Japanese Coated/Japanese Coated Paper - Side 2

PC

JapanesePostcard/Japanese Postcard

PCB

JapanesePostcardBack/Japanese Postcard/Japanese Postcard - Side 2

E

Envelope

If this option is not specified, multipurpose feeder Paper Type of the printer can be used.

-Mfo=mode

Specifies orientation for multipurpose feeder.  
Available orientations for multipurpose feeder are as follows.

le

Landscape

ler

Landscape (Rotated)

se

Portrait

*ser*

Portrait (Rotated)

*-Pon*

Specifies alternate tray.  
Available alternate trays are as follows.

0

Use printer settings

1

Display message

2

Feed from multipurpose feeder

3

Use nearest size (Adjust to fit)

4

Use larger size (Adjust to fit)

5

Use nearest size (No zoom)

6

Use larger size (No zoom)

*-St=mode*

Specifies feed separators from.  
Available feed separators from the following.

*auto*

AutoTray/Auto

1

1stTray/Tray 1 (Standard 250-sheet tray)

2

2ndTray/Tray 2 (Optional 550-sheet feeder)

*off*

Off

*-Sp*

Specifies printed separators.  
Available only when the paper tray for separators is specified.

*-Sb*

Specifies Skip Blank Pages.

*-Cm=mode*

Specifies output color.  
Available output colors are as follows.

*c*

Color (CMYK)

*k*

Black

*-Pr=mode*

Specifies print mode.

Available print modes are as follows.

hs  
High speed

hq  
High quality

sf  
Super fine

*-Cc=mode*

Specifies image types.  
Available image types are as follows.

0  
Off

1  
Photo

2  
sRGB

3  
Standard/ Normal

4  
Presentation

This option is available only for color printing and when entry data is RGB data.

*-Gc=mode*

Specifies RGB gamma correction.  
Available RGB gamma corrections are as follows.

1.0  
1.0

1.4  
1.4

1.8  
1.8

2.2  
2.2

2.6  
2.6

off  
Off

This option is available only for color printing and when entry data is RGB data.

*-Sc=mode*

Specifies screen.  
Available screens are as follows.

0  
Fineness

1  
Gradation

2

Auto

3

For Transparency

*-Gg=mode*

Specifies gray guaranteed.  
Available gray guaranteed options are as follows.

on

On

off

Off

This option is available only for color printing.

*-Ct*

Specifies color transformation.  
This option is available only for color printing.

*-Br=mode*

Specifies brightness adjustment.  
Available brightness adjustment option values are as follows.

+5

Bright 5

+4

Bright 4

+3

Bright 3

+2

Bright 2

+1

Bright 1

+0

Normal

-1

Dark 1

-2

Dark 2

-3

Dark 3

-4

Dark 4

-5

Dark 5

*-RGBc=mode*

Specifies RGB color correction.  
Available RGB color corrections are as follows.

10

Perceptual

11

Saturation

12

RelativeC

13

AbsoluteC

This option is available only for color printing and when entry data is RGB data.

`-RGBPr=mode`

Specifies RGB input profile.

Available RGB input profile option value are as follows.

0

sRGB

1

AdobeRGB

This option is available only for color printing and when entry data is RGB data.

`-RGBTp=mode`

Specifies RGB color temperature.

Available RGB color temperature option value are as follows.

5000

5000K

6000

6000K

9300

9300K

This option is available only for color printing and when entry data is RGB data.

`-Cb=cyan-low:cyan-middle:cyan-high:magenta-low:magenta-middle:magenta-high:yellow-low:yellow-middle:yellow-high:black-low:black-middle:black-high`

Specifies adjustment value for color balance of each color/density.

Available adjustment values are as follows.

+3

Dark 3

+2

Dark 2

+1

Dark 1

0

Normal

-1

Light 1

-2

Light 2

-3





- When an unacceptable character is specified for job owner name, "Unknown User" is used as job owner name.

 **NOTE:** Characters acceptable for job owner name are alphanumeric characters and symbols, except for space and colon.

 **NOTE:** Up to 32 characters are acceptable for job owner name.

- When an unacceptable character is specified for password, or when a specified password is not within the range of the allowable character length, the authentication password is treated as not specified.

 **NOTE:** Acceptable password length is between 4 and 12 characters.

Incomplete form of `-Jown` option is treated as no authentication setting being made. In such case, if authentication setting is made with the environmental variable, it is used as setting information.

## Example

To convert the XWD image into the PostScript language program and output it to a file, type as follows.

```
% xwd2ps2 file.xwd > file.ps
```

To output the XWD image to a printer, type as follows.

```
% xwd2ps2 file.xwd | lp
```

## Important

- When `-s` and `-S` are specified at the same time or when the same option is specified twice, the later setting will prevail.
- When the output size option (`-s`, `-S`) is not specified, scaling will be executed taking one pixel of the TIFF data as one pixel of the printer.
- If the print position option (`-l` *left bottom*) specifies a point beyond the printable area of the printer, data beyond the printable area will not be printed.

---

## Precautions and Limitations

### During Installation

Pay attention to the following points during the installation.

### Solaris

- Use `lpadmin` command to register the default printer.

```
# lpadmin -d PrinterName
```

- To inhibit the banner sheets output, change the value of `nobanner=no` to `nobanner=yes` that includes in the file corresponding to the printer name in `/etc/lp/interfaces/`.
- The printer registered by UX filter must not be changed by `admintool`.
- When `Content types: postscript` is displayed by typing `lpstat -p printername -l`, it's necessary to delete the printer and reinstall.

- To install UX filter into the default directory (`/usr/local/dellbin3130`), it's necessary to create `/usr/local` directory in advance.

## HP-UX

- The printer to specify as an output printer must be registered in your system. To register an output printer, use `sam` command and so on. See the HP-UX related manual for details.
- To install UX filter into the default directory (`/usr/local/dellbin3130`), it's necessary to create `/usr/local` directory in advance.

## During Printing

Pay attention to the following points during printing.

### Using `lp/lpr` Command (Solaris/HP-UX)

- If an option is specified incorrectly, no error message will be output. If printing is not executed after the `lp` command is executed, activate each utility individually and error messages will be output. (Using Solaris, the error message is displayed on the screen.)
- In text printing, the environmental variable `TXT2PS2OPTION` will be ignored.
- In text printing, if a BS code is found at the beginning of a line, the print position of the next character will be on the left of the beginning of the line.
- In text printing, when there are multiple tab codes in one line, the positions of tab may be off due to automatic line feed. If this happens, specify `l` or `w` option.
- In text printing, the number of columns specified by the `w` option does not reflect the number of characters actually printed. The actual number of single-byte characters to be printed is derived by deducting the output column position (out columns) specified by the `o` option from the number of columns specified by the `w` option.
- If the same option is specified, or if `s`, `S` are both specified, the one specified later will prevail.
- In printing images, If the print position option (`l`) specifies an area beyond the printable area of the printer, data beyond the printable area will not be printed. (Using Solaris, it's impossible to output images by `lp` command.)

### Using `txt2ps2` (Solaris/HP-UX)

- When the same option is specified twice, the later setting will prevail. As `TXT2PS2OPTION` is analyzed before the option of the command line, it is possible to temporarily modify the options already set in `TXT2PS2OPTION` by inputting at the command line
- The default output of `txt2ps2` cannot output the comment description (`%%page:m n`) of the page number. This is because the converted PostScript language program controls line feed and form feed. Thus, when the output of `txt2ps2` is to be taken as the output of another application (`psrev` of `TRANSCRIPT`, etc.), add the page number description by inserting the line command (`-l lines`).
- If a BS code is found at the beginning of a line, the print position of the next character will be on the left of the beginning of a line.
- When there are multiple tab codes in one line, the positions of tab may be off due to automatic line feed. If this happens, specify the `-l` or `-w` option.
- The number of columns specified by the `-w` option does not reflect the number of characters actually printed. The actual number of single-byte characters to be printed is derived by deducting the output column position (out columns) specified by the `o` option from the number of columns specified by the `w` option.
- The `-mg` option cannot be specified when `-w`, `-l`, `-o`, and `-L` option are specified.

- The start positions of margins of the margin command (`-mg=u:b:r:l`) are not set against the edge of paper. The margins are set against the printable area for paper allowed by the printer.
- Use the `-ps` option only when a PostScript file that contains no `%!` at the beginning of the file is used as the PostScript file. If a normal text file is input, it will not function correctly.
- To use the same options as those of the `dellpsif` filter by `TEXT2PS2OPTION`, set the user's home directory in the environmental variable `HOME`. If the environmental variable `HOME` is not set up, the same options as those of the `dellpsif` filter cannot be used. (Linux)

## Using `sunras2ps2/tiff2ps2/xwd2ps2` (`sunras2ps2` apply to Solaris only)

- If the same option is specified, or if `s`, `S` are both specified, the one specified later will prevail.
- If the size option (`s`, `S`) is not specified, scaling will be executed taking one pixel of the image data as one pixel of the printer.
- If the print position option (`-l` left bottom) specifies a point beyond the printable area of the printer, data beyond the printable area will not be printed.

## Using `tiff2ps2` (Solaris/HP-UX)

- There are four types of supported compression formats.  
 Huffman compression (CCITT Group 3 transformed Huffman run length encoding)  
 Fax-CCITT3 compression (facsimile-compatible CCITT Group 3)  
 PackBits compression  
 Non-compression

Even if the format is a supported format, the tiff that has multiple images in one file is not supported.

## Using `xwd2ps2` (Solaris/ HP-UX)

- There are three types of supported compression formats.  
 The visual class is Static Gray and the pixel is 1 bit.  
 The visual class is Pseudo Color and the pixel is 4 bits or 8 bit. The image format is Zpixmap.  
 The visual class is True Color and the pixel is 24 bits. The image format is Zpixmap.

## Printing PostScript Files (Solaris/ HP-UX)

- If same options for the PostScript file that contains options, such as paper size, are specified using `dellpsif` (Linux) or the `lp` command (Solaris/HP-UX), the specified option will be ignored.

## Printing Image Files (Solaris)

- To print image files from Solaris the user cannot specify the image file directly with the `lp` command for printing. Make use of `sunras2ps2`, `tiff2ps2`, `xwd2ps2` and convert the file to a PostScript file. Output it using the `lp` command after the conversion.

```
% xwd2ps2 file.xwd | lp
```

## The double- sided printing (Solaris/ HP-UX)

- The printer without an optional duplexer is unable to do double- sided printing.

## Header/footer Option (-Hd=position:format:page, -Hfheaderfont) (txt2ps2,sunras2ps2,tiff2ps2,xwd2ps2)

- If the paper size is not specified when using options, it outputs the header/footer at the position of A4-size paper. To specify the paper size at the same time to use header/footer option. (If the paper size for the PostScript file converted by using the option is specified by the option of `lp` command for example, the position of the header and footer cannot be changed.)
- The margin is specified automatically when the option is used. When the option to specify the margin is used at the same time, the value that is smaller than the value specified automatically as follows is ignored.  
In case of text files

Upper margin: 0.23 inch  
Lower margin: 0.06 inch  
Right margin: 0.03 inch  
Left margin: 0.09 inch

In case of images

Lower margin: 0.3 inch

- When using the option, the number of lines and the number of columns specified are ignored. Also, it is impossible to specify landscape and 2-column.
- In case of the PostScript file, it happens that the printer doesn't output all pages despite that *output all page* is specified. In such a case, specify *print the only top page*.
- It's impossible to use `lp` command in Solaris.

## TBCPFilter (Solaris/HP-UX)

- Make sure the TBCPFilter is available so the printer can specify the availability of the TBCPFilter.

## As for libtiff

Copyright © 1988-1997 Sam Leffler

Copyright © 1991-1997 Silicon Graphics, Inc.

THE SOFTWARE IS PROVIDED "AS-IS" AND WITHOUT WARRANTY OF ANY KIND, EXPRESS, IMPLIED OR OTHERWISE, INCLUDING WITHOUT LIMITATION, ANY WARRANTY OF MERCHANTABILITY OR FITNESS FOR A PARTICULAR PURPOSE.

IN NO EVENT SHALL SAM LEFFLER OR SILICON GRAGHICS BE LIABLE FOR ANY SPECIAL, INCIDENTAL, INDIRECT OR CONSEQUENTIAL DAMAGES OF ANY KIND, OR ANY DAMAGES WHATSOEVER RESULTING FROM LOSS OF USE, DATA OR PROFITS, WHETHER OR NOT ADVISED OF THE POSSIBILITY OF DAMAGE, AND ON ANY THEORY OF LIABILITY, ARISING OUT OF OR IN CONNECTION WITH THE USE OR PERFORMANCE OF THIS SOFTWARE.

---

[Back to Contents Page](#)

# Printing With CUPS (Linux)

- [Operation on Turbolinux FUJI or RedHat ES 4.0/5.0](#)
- [Operation on SUSE Linux Enterprise Desktop 10](#)

This section provides information for printing or setting up the printer driver with CUPS (Common UNIX Printing System) on Turbolinux FUJI, RedHat ES 4.0/5.0 or SUSE Linux Enterprise Desktop 10.

---

## Operation on Turbolinux FUJI or RedHat ES 4.0/5.0

### Setting Overview

Turbolinux FUJI or RedHat ES 4.0/5.0:

1. Install the printer driver.
2. Set up the print queue.
3. Specify the default queue.
4. Specify the printing options.

### Installing the Printer Driver

1. Double-click **Dell-3130cn-Color-Laser-x.x-x.noarch.rpm** in the *Drivers and Utilities* CD.
2. Type the administrator's password.
3. Click **Continue** in the **Completed System Preparation** window.

Installation starts. When the installation is complete, the window is automatically closed.

### Setting Up the Queue

To execute printing, you must set up the print queue on your workstation.

1. Open the URL "http://localhost:631" using a Web browser.
2. Click **Administration**.
3. Type `root` as the user name, and type the ROOT password as the password.
4. Click **Add Printer**.
5. Type the printer's name in the **Name** box in the **Add New Printer** window, and then click **Continue**.

The **Location** and **Description** do not have to be specified.

6. Select **LPD/LPR Host or Printer** from **Device** menu, and then click **Continue**.
7. Type the printer's IP address in **Device URI**.

Format: `lpd://xxx.xxx.xxx.xxx` (printer's IP address)

8. Select **Dell** from the **Make** menu, and then click **Continue**.

9. Select **Dell 3130cn Color Laser...** from the **Model** menu, and then click **Continue**.

The message **Printer xxx has been added successfully**. appears.

The set up is complete.

When you have finished setting up the queue you can print jobs from the software program. Start the print job from the software program, and then specify the queue in the print dialog box.

However, sometimes you can only print from the default queue depending on the software program (for example Mozilla). In these cases, before you start printing, set queue you want to print to as the default queue. For information on specifying the default queue, see "[Setting the Default Queue](#)."

## Setting the Default Queue

1. Select **Main Menu® System Tools® Terminal**.
2. Type the following command in the terminal window.

```
su
(Type the administrator's password)
lpadmin -d (The queue name)
```

## Specifying the Printing Options

You can specify the printing options such as color mode or double-sided printing.

1. Open the URL "http://localhost:631" using a Web browser.
2. Click **Manage Printers**.
3. Click **Configure Printer** of the queue for which you want to specify the printing options.
4. Type `root` as the user name, and type the administrator's password.
5. Specify the required settings, and then click **Continue**.

The message **Printer xxx has been configured successfully**. appears.

The setting is complete. Execute printing from the software program.

## Uninstalling the Printer Driver

1. Select **Main Menu® System Tools® Terminal**.
2. Type the following command in the terminal window.

```
su
(Type the administrator's password)
rpm -e Dell-3130cn-Color-Laser
```

The printer driver is uninstalled.

---

# Operation on SUSE Linux Enterprise Desktop 10

## Installing the Printer Driver

1. Double-click **Dell-3130cn-Color-Laser-x.x-x.noarch.rpm** in the *Drivers and Utilities* CD.
2. Type the administrator's password and click **Install**.

Installation starts. When the installation is complete, the window is automatically closed.

## Setting Up the Queue

To execute printing, you must set up the print queue on your workstation.

1. Select **Computer® More Applications...** and select **YaST** on the Application Browser.
2. Type the administrator's password.

**YaST Control Center** is activated.

3. Select **Hardware** on the YaST Control Center and select **Printer**.
4. **Printer setup: Autodetected printers** is activated.

For USB connections:

- a. Select **Dell 3130cn Color Laser on USB (/Dell/3130cn%20Color%20Laser or /dev/usb/lp\*)** as **Available are**, and then click **Configure...**
- b. Confirm the settings in **Edit configuration**, and then click **OK**.

For parallel connections:

- a. Click **Add**.
- b. Select **Directly Connected Printers** as **Printer Type**, and then click **Next**.
- c. Select **Parallel printer** as **Printer Type**, and then click **Next**.
- d. Click **Next**.
- e. Set the name of the printer queue in **Queue name**, and type the queue name for printing in **Name for printing**.

The **Description of Printer** and **Location of Printer** do not have to be specified.

- f. Select the **Do Local Filtering** check box, and then click **Next**.
- g. Select **DELL** in **Select manufacturer**. Select **3130cn Color Laser** in **Select Model**, and then click **Next**.
- h. Confirm the settings in **Edit configuration**, and then click **OK**.

For network connections:

- a. Click **Add**.
- b. Select **Network Printers** as **Printer Type**, and then click **Next**.
- c. Select the **Print via LPD-Style Network Server** as **Printer Type**, and then click **Next**.
- d. Type the printer's IP address in **Host name of the printer server**. And type the name of the printer queue in **Name of the remote queue**, and then click **Next**.
- e. Type the printer name in **Name for printing**.

The **Description of Printer** and **Location of Printer** do not have to be specified.

- f. Select the **Do Local Filtering** check box, and then click **Next**.
- g. Select **DELL** as **Select manufacturer**. Select **3130cn Color Laser** as **Select Model**, and then click **Next**.



h. Confirm the settings in **Edit configuration**, and then click **OK**.

5. Click **Finish**.

## Printing From the Application Program

When you have finished setting up the queue you can print jobs from the application program. Start the print job from the application program, and then specify the queue in the print dialog box.

However, sometimes you can only print from the default queue depending on the application program (for example Mozilla). In these cases, before you start printing, set queue you want to print to as the default queue. For information on specifying the default queue, see "[Setting the Default Queue](#)."

## Setting the Default Queue

1. To activate the **Printer setup: Autodetected printers**, do the following.
  - a. Select **Computer® More Applications...** and select **YaST** on the Application Browser.
  - b. Type the administrator's password.  
  
**YaST Control Center** is activated.
  - c. Select **Hardware** on the YaST Control Center and select **Printer**.
2. Select the printer you want to set to default on the **Printer Configuration**, and select **Set default** as **Other**.
3. Click **Finish**.

## Specifying the Printing Options

You can specify the printing options such as color mode or double-sided printing.

1. Open a Web Browser.
2. Type `http://localhost:631/admin` in **Location**, and then press the <Enter> key.
3. Type `root` as the user name, and type the administrator's password.

The **CUPS** window appears.



**NOTE:** Set the password for authority as the printer administrator before setting the printer queue. If you have not set it, go to "[Setting the Password for Authority as the Printer Administrator](#)."

4. Click **Manage Printers**.
5. Specify the required settings, and then click **Continue**.

The message **Printer xxx has been configured successfully**. appears.

The setting is complete. Execute printing from the application program.

## Setting the Password for Authority as the Printer Administrator

You must set the password for authority as the printer administrator to do operations as the printer administrator.

1. Select **Computer® More Applications...** and select **Konsole** on the Application Browser.

2. Type the following command on the terminal window.

```
su
(Type the administrator's password.)
lppasswd -g sys -a root
(Type the password for authority as the printer administrator after the Enter password prompt.)
(Retype the password for authority as the printer administrator after the Enter password again prompt.)
```

## Uninstalling the Printer Driver

1. Select **Computer® More Applications...** and select **Konsole** on the Application Browser.
2. Type the following command on the terminal window.

```
su
(Type the administrator's password)
rpm -e Dell-3130cn-Color-Laser
```

The printer driver is uninstalled.

---

[Back to Contents Page](#)

# Appendix

- [Dell Technical Support Policy](#)
  - [Warranty and Return Policy](#)
  - [Contacting Dell](#)
- 

## Dell Technical Support Policy

Technician-assisted technical support requires the cooperation and participation of the customer in the troubleshooting process and provides for restoration of the operating system, software program and hardware drivers to the original default configuration as shipped from Dell, as well as the verification of appropriate functionality of the printer and all Dell-installed hardware. In addition to this technician assisted technical support, online technical support is available at Dell Support. Additional technical support options may be available for purchase.

Dell provides limited technical support for the printer and any Dell-installed software and peripherals. Support for third-party software and peripherals is provided by the original manufacturer, including those purchased and/or installed through Software & Peripherals (DellWare), ReadyWare, and Custom Factory Integration (CFI/DellPlus).

## Online Services

You can learn about Dell products and services on the following websites:

[www.dell.com](http://www.dell.com)

[www.dell.com/ap](http://www.dell.com/ap) (Asian/Pacific countries only)

[www.dell.com/jp](http://www.dell.com/jp) (Japan only)

[www.euro.dell.com](http://www.euro.dell.com) (Europe only)

[www.dell.com/la](http://www.dell.com/la) (Latin American and Caribbean countries)

[www.dell.ca](http://www.dell.ca) (Canada only)

You can access Dell Support through the following websites and e-mail addresses:

- Dell Support websites

[support.dell.com](http://support.dell.com)

[support.jp.dell.com](http://support.jp.dell.com) (Japan only)

[support.euro.dell.com](http://support.euro.dell.com) (Europe only)

- Dell Support e-mail addresses

mobile\_support@us.dell.com

support@us.dell.com

la-techsupport@dell.com (Latin America and Caribbean countries only)

apsupport@dell.com (Asian/Pacific countries only)

- Dell Marketing and Sales e-mail addresses

apmarketing@dell.com (Asian/Pacific countries only)

sales\_canada@dell.com (Canada only)

- Anonymous file transfer protocol (FTP)

## Warranty and Return Policy

Dell Computer Corporation ("Dell") manufactures its hardware products from parts and components that are new or equivalent to new in accordance with industry-standard practices. For information about the Dell warranty for your printer, see [support.dell.com](http://support.dell.com).

## Recycling Information

It is recommended that customers dispose of their used computer hardware, monitors, printers, and other peripherals in an environmentally sound manner. Potential methods include reuse of parts or whole products and recycling of products, components, and/or materials.

For specific information on Dell's worldwide recycling programs, see [www.dell.com/recyclingworldwide](http://www.dell.com/recyclingworldwide).

---

## Contacting Dell

For customers in the United States, call 800-WWW-Dell (800-999-3355).



**NOTE:** If you do not have an active Internet connection, you can find contact information on your purchase invoice, packing slip, bill, in your Dell catalog.

Dell provides several online and telephone-based support and service options. Availability varies by country and product, and some services may not be available in your area. To contact Dell for sales, technical support, or customer service issues:

1. Visit [support.dell.com](http://support.dell.com).
  2. Verify your country or region in the **Choose A Country/Region** drop-down menu at the bottom of the page.
  3. Click **Contact Us** on the left side of the page.
  4. Select the appropriate service or support link based on your need.
  5. Choose the method of contacting Dell that is convenient for you.
- 

[Back to Contents Page](#)

## Free Manuals Download Website

<http://myh66.com>

<http://usermanuals.us>

<http://www.somanuals.com>

<http://www.4manuals.cc>

<http://www.manual-lib.com>

<http://www.404manual.com>

<http://www.luxmanual.com>

<http://aubethermostatmanual.com>

Golf course search by state

<http://golfingnear.com>

Email search by domain

<http://emailbydomain.com>

Auto manuals search

<http://auto.somanuals.com>

TV manuals search

<http://tv.somanuals.com>