

Model No. RBBE14210

Serial No. _____

Write the serial number in the space above for reference.

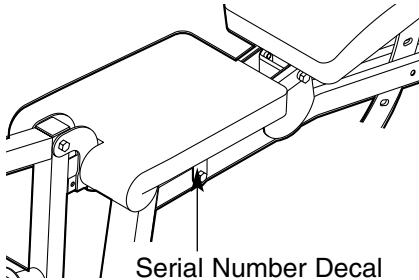

QUESTIONS?

As a manufacturer, we are committed to providing complete customer satisfaction. If you have questions, or if there are missing parts, we will guarantee complete satisfaction through direct assistance from our factory.

TO AVOID DELAYS, PLEASE CALL DIRECT TO OUR TOLL-FREE CUSTOMER HOT LINE. The trained technicians on our customer hot line will provide immediate assistance, free of charge to you.

CUSTOMER HOT LINE:
1-800-999-3756
Mon.-Fri., 6 a.m.-6 p.m. MST

CAUTION

Read all precautions and instructions in this manual before using this equipment. Save this manual for future reference.

USER'S MANUAL

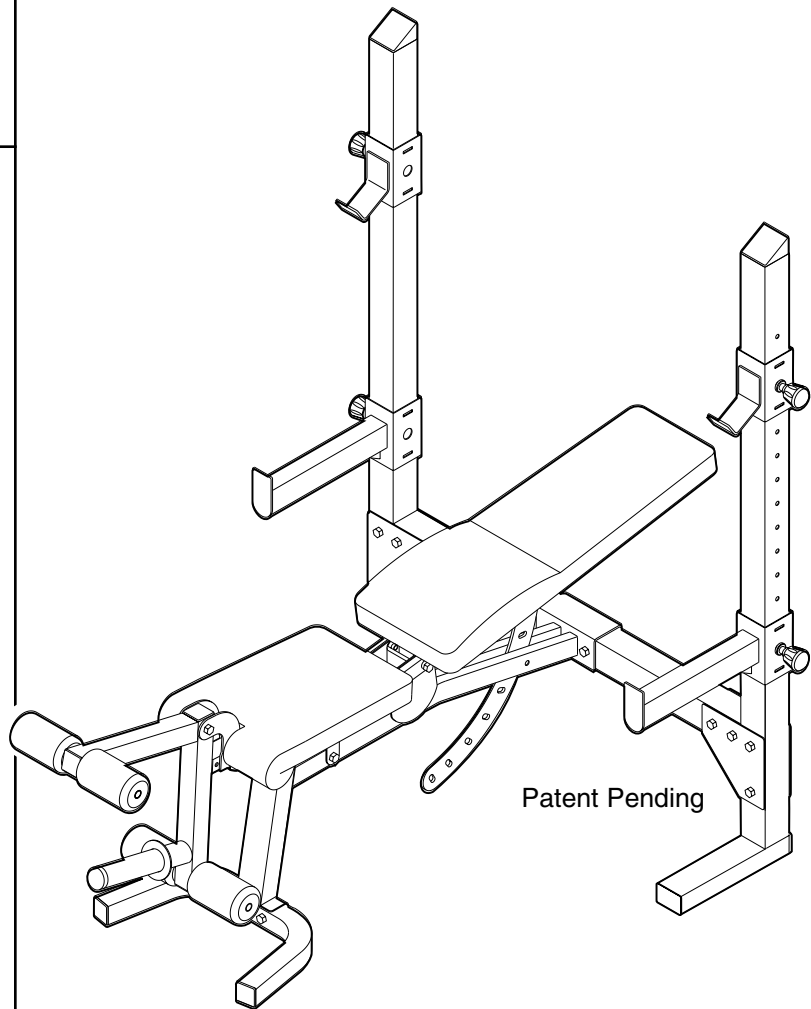

Visit our website at
www.reebokhomefitness.com

new products, prizes,
fitness tips, and much more!

TABLE OF CONTENTS

WARNING DECAL PLACEMENT	2
IMPORTANT PRECAUTIONS	3
BEFORE YOU BEGIN	4
PART IDENTIFICATION CHART	5
ASSEMBLY	6
ADJUSTMENTS	10
EXERCISE GUIDELINES	11
PART LIST	14
EXPLODED DRAWING	15
ORDERING REPLACEMENT PARTS	Back Cover
LIMITED WARRANTY	Back Cover

WARNING DECAL PLACEMENT

! WARNING

- Misuse of this product may result in serious injury.
- Read user's manual and follow all warnings and operating instructions prior to use.
- Do not allow children on or around machine.
- Replace label if damaged, illegible, or removed.

The decals shown here have been placed on the weight bench. If a decal is missing, or if it is not legible, please call our Customer Service Department toll-free at 1-800-999-3756, Monday through Friday, 6 a.m. until 6 p.m. Mountain Time, to order a free replacement decal. Apply the replacement decal in the location shown.

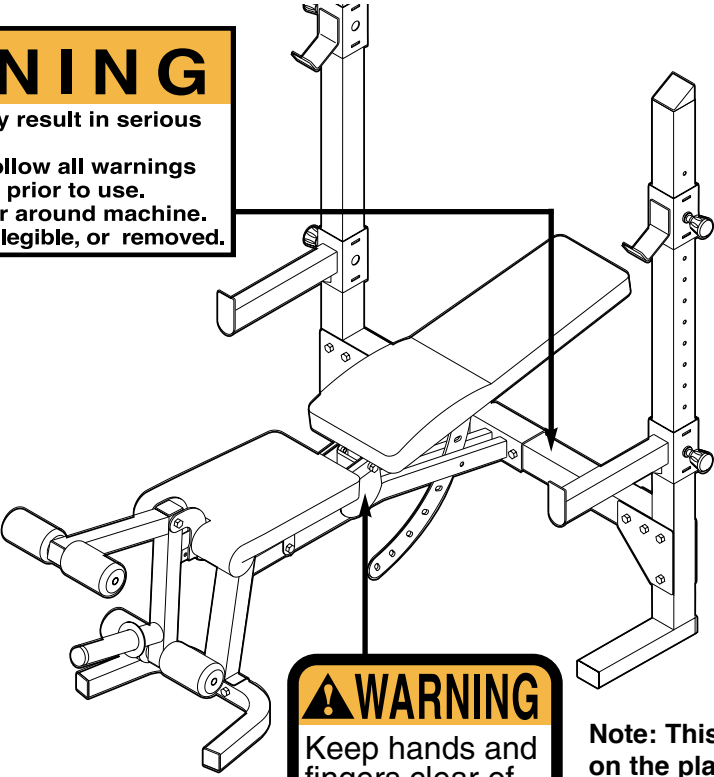
A technical line drawing of a weight bench. Two arrows point from the warning decal boxes to the plastic plates on the left and right sides of the bench's seat area.

! WARNING

Keep hands and fingers clear of this area.

Note: This decal is placed on the plastic plate, on both sides of the weight bench.

REEBOK and the Vector Logo  are registered trademarks and service marks of Reebok. This product is manufactured and distributed under license from Reebok International.

IMPORTANT PRECAUTIONS

⚠️ WARNING: To reduce the risk of serious injury, read the following important precautions before using the weight bench.

1. Read all instructions in this manual before using the weight bench. Use the weight bench only as described in this manual.
2. The weight bench is intended for home use only. Do not use the weight bench in any commercial, rental, or institutional setting.
3. It is the responsibility of the owner to ensure that all users of the weight bench are adequately informed of all precautions.
4. Use the weight bench only on a level surface. Cover the floor beneath the weight bench to protect the floor.
5. Make sure all parts are properly tightened each time you use the weight bench. Replace any worn parts immediately.
6. Keep children under the age of 12 and pets away from the weight bench at all times.
7. Always wear athletic shoes for foot protection while exercising.
8. Keep hands and feet away from moving parts.
9. Always keep an equal amount of weight on each end of your barbell when you are using it. When adding or removing weights, always keep some weight on both ends of the barbell to prevent the barbell from tipping. Note: The weight bench does not include a barbell or weights.
10. Do not use a barbell that is longer than six feet with the weight bench.
11. When you place weight on the weight rests, make sure that you place at least ten pounds on the leg lever to balance the weight bench.
12. When you are using the leg lever, place a barbell with the same amount of weight on the weight rests to balance the bench.
13. When adjusting the position of the backrest, make sure that the backrest adjustment knob is fully inserted through the backrest bracket.
14. Do not sit on the top end of the backrest; this will cause the weight bench to tip.
15. Make sure that the large adjustment knobs are inserted completely and tightened into the uprights before you begin any exercise.
16. Always set both weight rests and both weight spotters at the same height.
17. The weight bench is designed to support a maximum of 560 pounds, including the user, a barbell, and weights. Do not place more than 310 pounds, including a barbell and weights, on the weight rests. Do not place more than 150 pounds on the leg lever.
18. Always exercise with a partner. When you are performing bench press exercises, your partner should stand behind you to catch the barbell if you cannot complete a repetition.
19. If you feel pain or dizziness while exercising, stop immediately and begin cooling down.

⚠️ WARNING: Before beginning this or any exercise program, consult your physician. This is especially important for persons over the age of 35 or persons with pre-existing health problems. Read all instructions before using. ICON assumes no responsibility for personal injury or property damage sustained by or through the use of this product.

BEFORE YOU BEGIN

Thank you for selecting the versatile REEBOK® RST250 weight bench. The REEBOK® RST250 is designed to help you develop every major muscle group of the body. Whether your goal is a shapely figure, dramatic increase in muscle size and strength, or a healthier cardiovascular system, the RST250 will help you achieve the specific results you want.

For your benefit, read this manual carefully before using the weight bench. If you have additional questions, please call our Customer Service Department



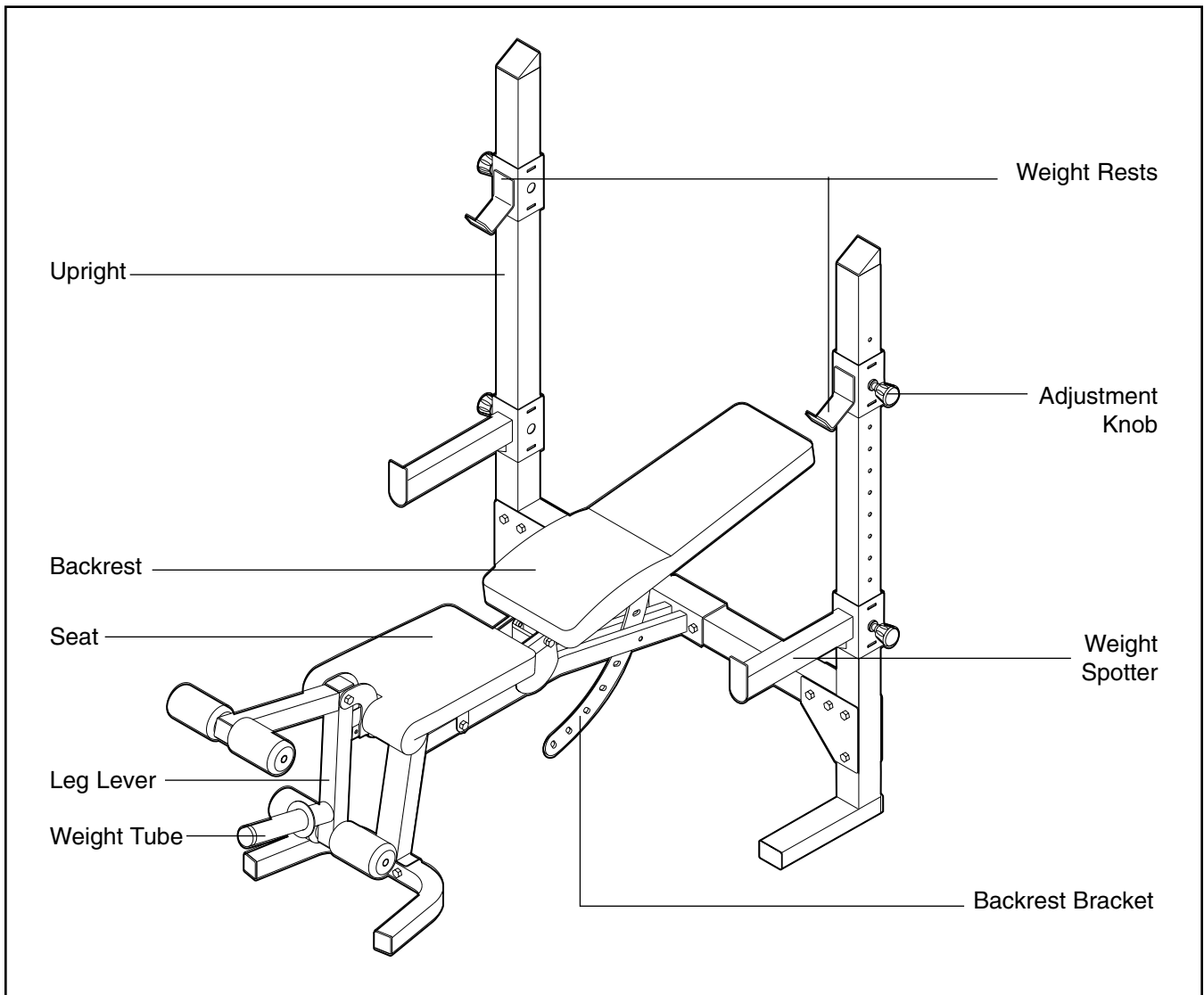

toll-free at 1-800-999-3756, Monday through Friday, 6 a.m. until 6 p.m. Mountain Time (excluding holidays). To help us assist you, please note the product model number and serial number before calling. The model number is RBBE14210. The serial number can be found on a decal attached to the weight bench (see the front cover of this manual).

Before reading further, please review the drawing below and familiarize yourself with the parts that are labeled.

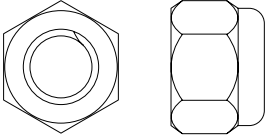
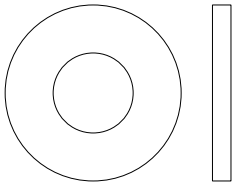
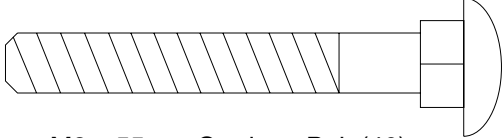

PART IDENTIFICATION CHART

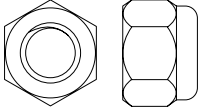
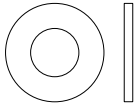
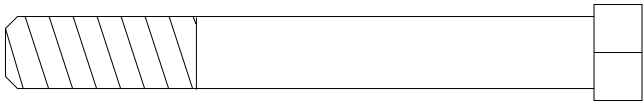
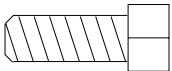
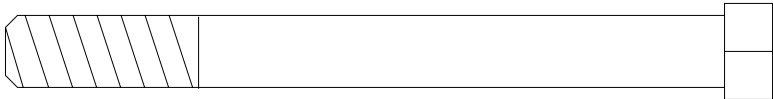
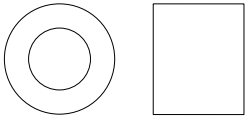
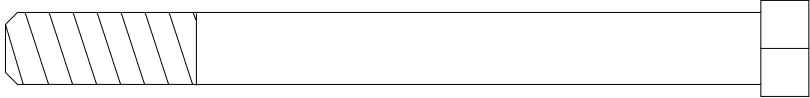
Refer to the drawings below to identify small parts used in assembly. The number in parentheses by each drawing is the key number of the part, from the PART LIST on page 14 of this manual. **Note: Some small parts may have been pre-attached. If a part is not in the parts bag, check to see if it has been pre-attached.**

 M6 x 50mm Bolt (39)	 M10 Nylon Locknut (35)	 M10 Washer (27)
 M8 x 55mm Carriage Bolt (40)		
 M10 x 65mm Bolt (36)	 M8 Nylon Locknut (42)	 M6 Washer (19)
 M10 x 78mm Bolt (28)		 M6 x 16mm Bolt (31)
 M10 x 95mm Bolt (34)		 12.5mm Spacer (33)
 M10 x 100mm Bolt (38)		
 M10 x 140mm Bolt (37)		

ASSEMBLY

Make Things Easier for Yourself



This manual is designed to ensure that the weight bench can be assembled successfully by anyone. Most people find that by setting aside plenty of time, assembly will go smoothly.

Before beginning assembly, carefully read the following information and instructions:

- Assembly requires two people.
- For help identifying small parts, use the PART IDENTIFICATION CHART on page 5.
- Tighten all parts as you assemble them, unless instructed to do otherwise.
- As you assemble the weight bench, make sure all parts are oriented as shown in the drawings.

- Place all parts in a cleared area and remove the packing materials. Do not dispose of the packing materials until assembly is completed.

The following tools (not included) are required for assembly:

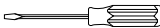
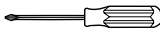
- **Two adjustable wrenches** 
- **One rubber mallet** 
- **One standard screwdriver** 
- **One Phillips screwdriver** 
- **Lubricant, such as grease or petroleum jelly, and soapy water.**

Assembly will be more convenient if you have a socket set, a set of open-end or closed-end wrenches, or a set of ratchet wrenches.

1. **Before assembling the weight bench, be sure that you have read and understand the information in the box above.**

Press two 75mm x 50mm Inner Caps (20) into the lower end of each Upright (4).

Orient the Uprights (4) with the adjustment holes on the outside.

Position the Crossbar (3) between the two Uprights (4). **Note: Make sure the warning decal on the Crossbar is in the position shown.** Attach the Crossbar to each Upright with four M10 x 95mm Bolts (34), two Support Plates (21), and four M10 Nylon Locknuts (35). **Do not tighten the Nylon Locknuts yet.**

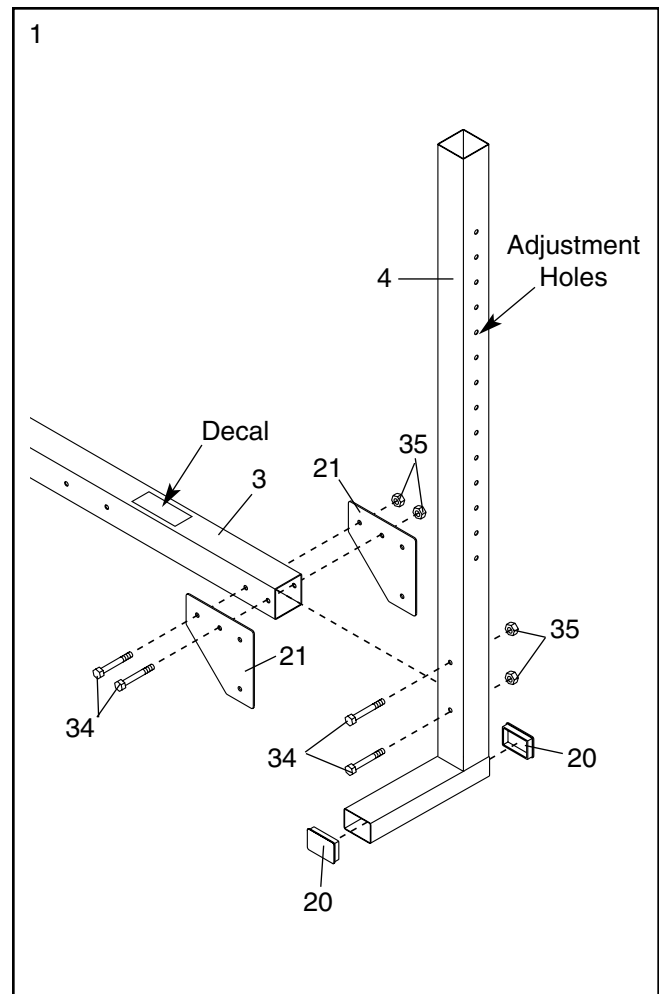

- Attach the Frame (1) to the Crossbar (3) with two M10 x 95mm Bolts (34) and two M10 Nylon Locknuts (35). **Do not tighten the Nylon Locknuts yet.**

Press two 8mm Bushings (32) into the indicated locations on the Frame (1).

Press a 75mm x 50mm Inner Cap (20) into the Frame (1).

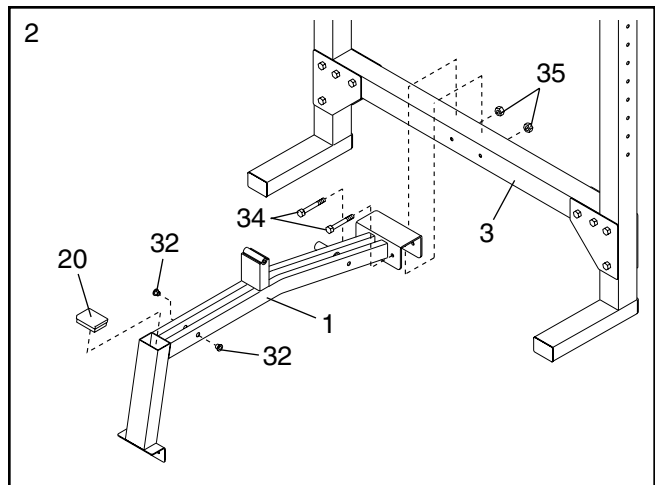

- Press two 50mm Square Inner Caps (22) into the Front Stabilizer (2).

Attach the Front Stabilizer (2) to the Frame (1) with two M10 x 65mm Bolts (36), two M10 Washers (27), and two M10 Nylon Locknuts (35).

Tighten the M10 Nylon Locknuts (35) used in steps 1–3.

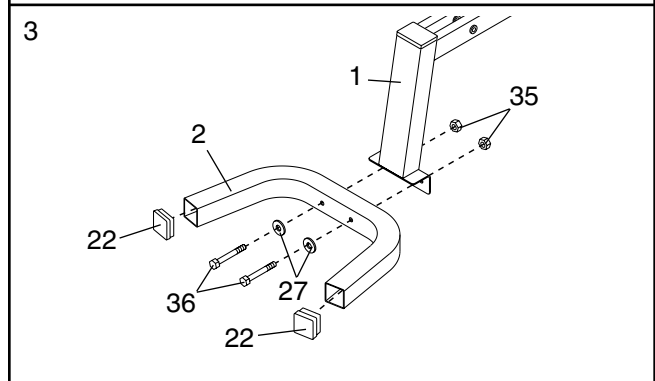

- Press four 20mm x 40mm Inner Caps (43) into the Backrest Frames (10). **Orient the Backrest Frames as shown. Note: The indents in the Backrest Frames must be on top.**

Attach the Backrest Bracket (9) to the Backrest Frames (10) with four M8 x 55mm Carriage Bolts (40) and four M8 Nylon Locknuts (42). **Do not tighten the Nylon Locknuts yet.**

Attach the Backrest (8) to the Backrest Frames (10) with four M6 x 50mm Bolts (39) and four M6 Washers (19). **Do not tighten the Bolts yet. The Backrest must be oriented as shown.**

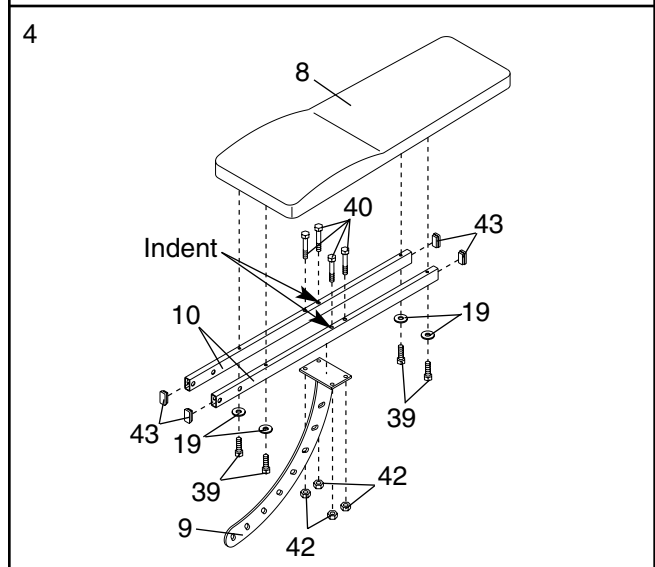

- Screw the Backrest Adjustment Knob (30) into the Frame (1). Pull the Knob out as far as it will go and lower the Backrest Bracket (9) between the two tubes on the Bench Frame. Snap the Knob into an adjustment hole in the Backrest Bracket.

Lubricate an M10 x 140mm Bolt (37). Attach the indicated holes in the Backrest Frames (10) and the two Plastic Plates (26) to the Bench Frame (1) with the Bolt, two M10 Washers (27), and an M10 Nylon Locknut (35). **Note: The warning decals on the Plastic Plates must face away from the bench. Do not overtighten the M10 Nylon Locknut; the Backrest (8) must be able to pivot easily.**

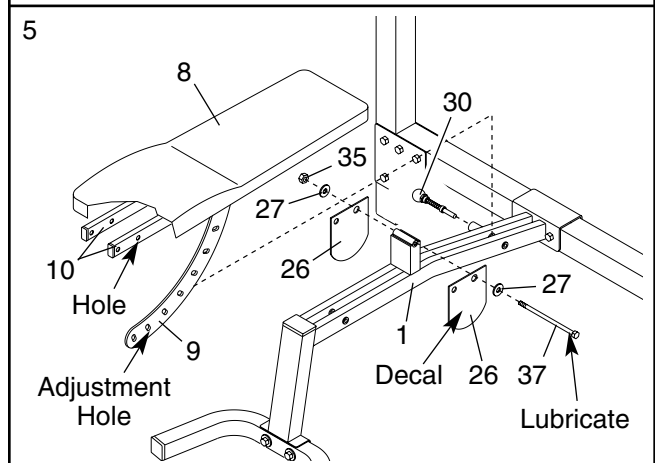

- Press the 40mm x 50mm Inner Cap (41) into the Seat Frame (6). Press six 8mm Bushings (32) into the Seat Frame and the Backrest Frames (10).

Attach the Seat Bracket (14) to the Seat Frame (6) with an M10 x 78mm Bolt (28) and an M10 Nylon Locknut (35).

Attach the Seat Bracket (14) to the Frame (1) with an M10 x 100mm Bolt (38) and an M10 Nylon Locknut (35).

Lubricate an M10 x 140mm Bolt (37). Attach the bottom holes in both the Backrest Frames (10) and the two Plastic Plates (26) to the Seat Frame (6) with the Bolt, two 12.5mm Spacers (33), and an M10 Nylon Locknut (35). **Do not overtighten the M10 Nylon Locknut; the Backrest (8) must be able to pivot easily.**

Tighten the M8 Nylon Locknuts (42) and the M6 x 50mm Bolts (39) used in step 4.

- Press two 8mm Bushings (32) into the Leg Lever Bracket (13).

Attach the Leg Lever Bracket (13) to the Seat Frame (6) with the Small Adjustment Knob (29).

- Press three 50mm Square Inner Caps (22) into the Leg Lever (15). Press a 50mm Round Inner Cap (5) into the weight tube.

Lubricate an M10 x 78mm Bolt (28). Attach the Leg Lever (15) to the Leg Lever Bracket (13) with the Bolt and an M10 Nylon Locknut (35). **Do not overtighten the Nylon Locknut; the Leg Lever must pivot freely.**

- Press four 19mm Round Inner Caps (24) into the ends of the two Pad Tubes (25).

Insert the Pad Tubes (25) into the holes in the Leg Lever (15). Slide two Foam Pads (23) onto each Pad Tube.

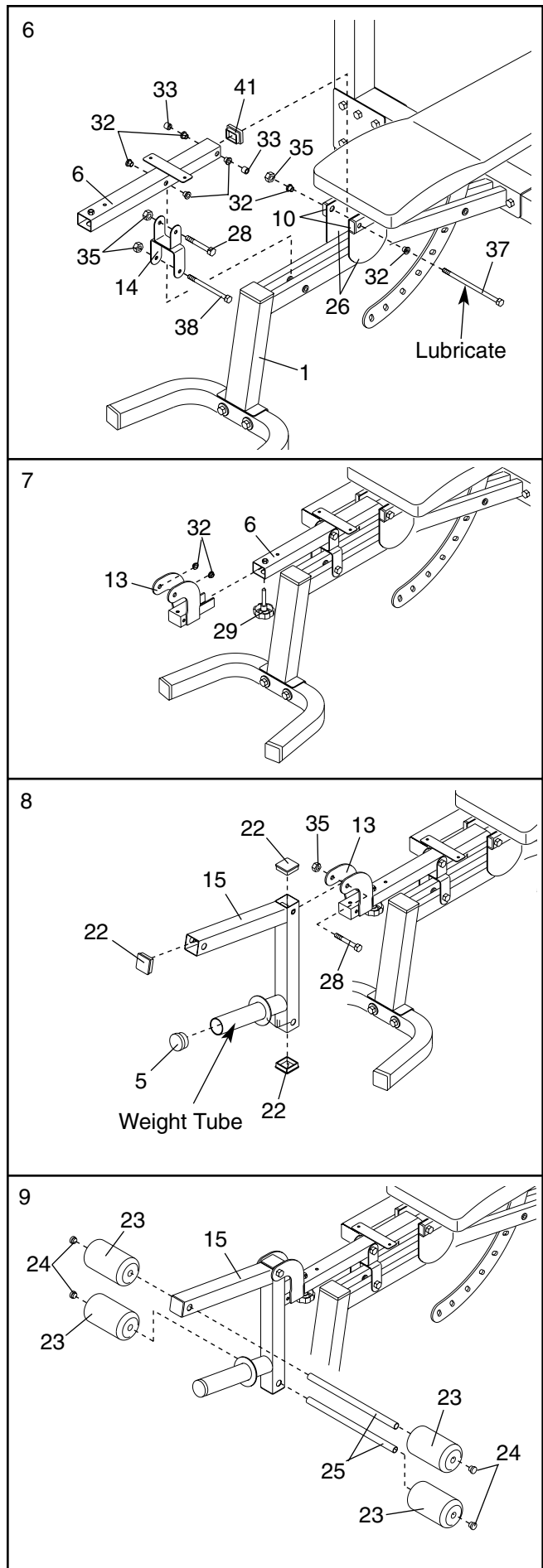

10. Attach the Seat (7) to the bracket on the Seat Frame (6) using two M6 x 16mm Bolts (31). Attach the other end of the Seat to the Seat Frame with an M6 Washer (19) and an M6 x 50mm Bolt (39).

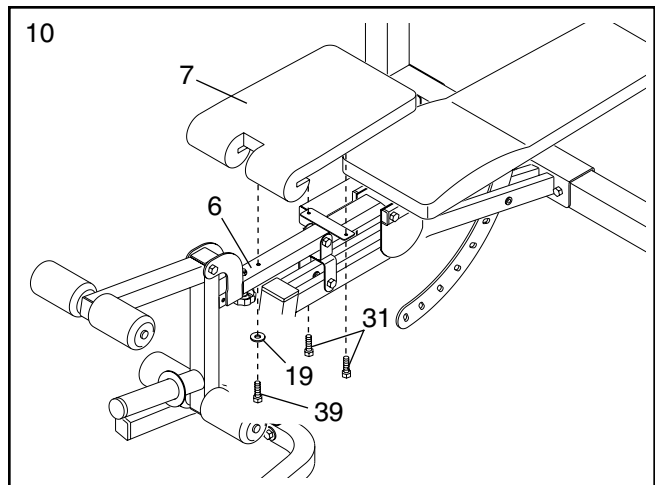

11. Press Square Bushings (16) into the top and bottom of the Left Weight Rest (12) and the Left Weight Spotter (11). Screw a Large Adjustment Knob (18) into the Weight Rest and the Weight Spotter.

Pull the Large Adjustment Knob (18) in the Left Weight Spotter (11) out as far as it will go. Slide the Weight Spotter over the left Upright (4). Snap the Knob into one of the lower adjustment holes in the Upright. Turn the Knob clockwise until it is tight. Attach the Left Weight Rest (12) to the Upright in the same manner. Press an Upright Cap (17) into the top of the Upright.

Repeat this step with the right Upright (not shown).

Note: Make sure that both Weight Rests (12, 44) and both Weight Spotters (11, 45) are set at the same height.

12. **Make sure that all parts are properly tightened before you use the weight bench.** The use of all remaining parts will be explained in ADJUSTMENTS on page 10.

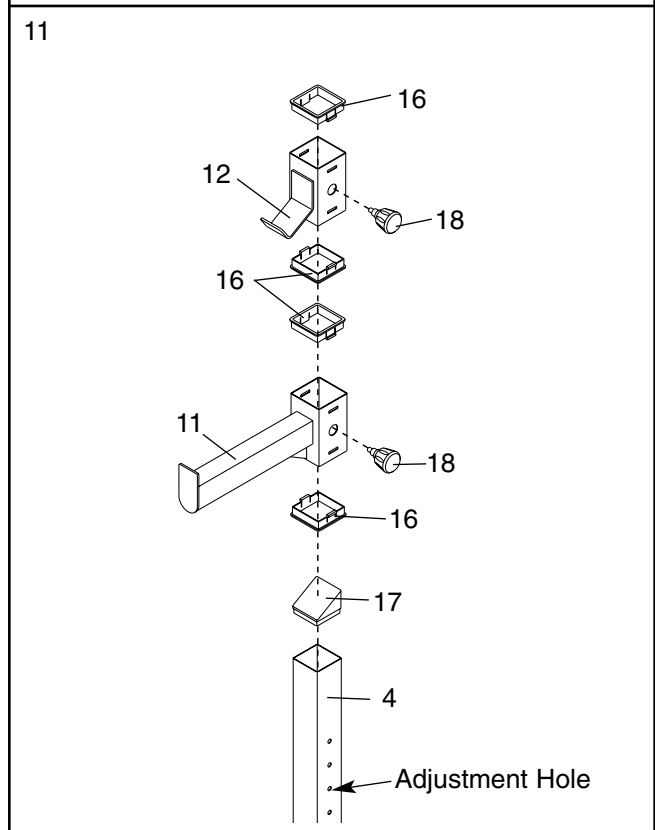

ADJUSTMENTS

The weight bench is designed to be used with your own weight set (not included). The steps below explain how the weight bench can be adjusted. See EXERCISE GUIDELINES on page 11 for important exercise information and refer to the accompanying exercise guide to see the correct form for several exercises.

Make sure all parts are properly tightened each time you use the weight bench. Replace any worn parts immediately. The weight bench can be cleaned with a damp cloth and a mild, non-abrasive detergent. Do not use solvents.

ADJUSTING THE BACKREST

The Backrest (8) can be used in eight different positions. To adjust the Backrest, hold the Backrest up and pull the Backrest Adjustment Knob (30) out as far as it will go. Move the Backrest to the desired position and insert the Knob into an adjustment hole in the Backrest Bracket (9).

⚠ WARNING: When adjusting the position of the Backrest (8), first remove all weight from the Leg Lever (15). Make sure that the Backrest Adjustment Knob (30) is fully inserted through the Backrest Bracket (9).

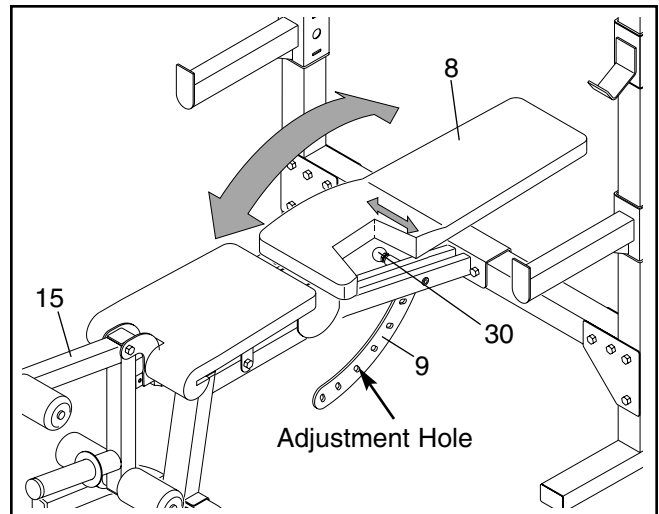

ADJUSTING THE WEIGHT REST AND WEIGHT SPOTTER

Before beginning an exercise, move the Weight Rests (12, 44 [not shown]) and the Weight Spotters (11, 45 [not shown]) to sets of holes in the Uprights (4) that are best suited for that exercise. Do this by turning the Adjustment Knobs (18) counterclockwise until loose. Pull the Knobs out and slide the Weight Rests or the Weight Spotters to the desired height. Snap the Knobs into the adjustment holes in the Uprights and turn the Knobs clockwise until tight.

The selected holes for the Weight Spotters (11, 45 [not shown]) should represent the lowest point to which you want the barbell to go during the exercise. The selected holes for the Weight Rests (12, 44 [not shown]) should be at a comfortable height for lifting and replacing the barbell. Perform the exercise as shown on the accompanying exercise guide. **Note: Make sure the Adjustment Knobs (18) are fully tightened.**

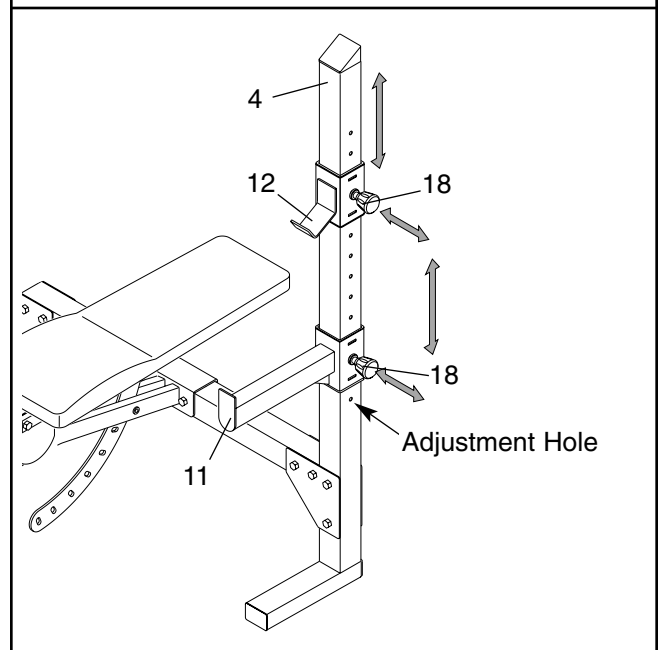

⚠ WARNING: Always set both Weight Rests (12, 44) at the same height and both Weight Spotters (11, 45) at the same height.

EXERCISE GUIDELINES

THE FOUR BASIC TYPES OF WORKOUTS

Muscle Building

To increase the size and strength of your muscles, push them close to their maximum capacity. Your muscles will continually adapt and grow as you progressively increase the intensity of your exercise. You can adjust the intensity level of an individual exercise in two ways:

- by changing the amount of weight used
- by changing the number of repetitions or sets performed. (A “repetition” is one complete cycle of an exercise, such as one sit-up. A “set” is a series of repetitions.)

The proper amount of weight for each exercise depends upon the individual user. You must gauge your limits and select the amount of weight that is right for you. Begin with 3 sets of 8 repetitions for each exercise you perform. Rest for 3 minutes after each set. When you can complete 3 sets of 12 repetitions without difficulty, increase the amount of weight.

Toning

You can tone your muscles by pushing them to a moderate percentage of their capacity. Select a moderate amount of weight and increase the number of repetitions in each set. Complete as many sets of 15 to 20 repetitions as possible without discomfort. Rest for 1 minute after each set. Work your muscles by completing more sets rather than by using high amounts of weight.

Weight Loss

To lose weight, use a low amount of weight and increase the number of repetitions in each set. Exercise for 20 to 30 minutes, resting for a maximum of 30 seconds between sets.

Cross Training

Cross training is an efficient way to get a complete and well-balanced fitness program. An example of a balanced program is:

- Plan weight training workouts on Monday, Wednesday, and Friday.
- Plan 20 to 30 minutes of aerobic exercise, such as cycling or swimming, on Tuesday and Thursday.
- Rest from both weight training and aerobic exercise for at least one full day each week to give your body time to regenerate.

The combination of weight training and aerobic exercise will reshape and strengthen your body, plus develop your heart and lungs.

PERSONALIZING YOUR EXERCISE PROGRAM

Determining the exact length of time for each workout, as well as the number of repetitions or sets completed, is an individual matter. It is important to avoid overdoing it during the first few months of your exercise program. You should progress at your own pace and be sensitive to your body’s signals. If you experience pain or dizziness at any time while exercising, stop immediately and begin cooling down. Find out what is wrong before continuing. Remember that adequate rest and a proper diet are important factors in any exercise program.

WARMING UP

Begin each workout with 5 to 10 minutes of stretching and light exercise to warm up. Warming up prepares your body for more strenuous exercise by increasing circulation, raising your body temperature and delivering more oxygen to your muscles.

WORKING OUT

Each workout should include 6 to 10 different exercises. Select exercises for every major muscle group, emphasizing areas that you want to develop most. To give balance and variety to your workouts, vary the exercises from session to session.

Schedule your workouts for the time of day when your energy level is the highest. Each workout should be followed by at least one day of rest. Once you find the schedule that is right for you, stick with it.

EXERCISE FORM

Maintaining proper form is an essential part of an effective exercise program. This requires moving through the full range of motion for each exercise, and moving only the appropriate parts of the body. Exercising in an uncontrolled manner will leave you feeling exhausted. On the exercise guide accompanying this manual you will find photographs showing the correct form for several exercises, and a list of the muscles affected. Refer to the muscle chart on page 12 to find the names of the muscles.

The repetitions in each set should be performed smoothly and without pausing. The exertion stage of each repetition should last about half as long as the return stage. Proper breathing is important. Exhale during the exertion stage of each repetition and inhale during the return stroke. Never hold your breath.

Rest for a short period of time after each set. The ideal resting periods are:

- Rest for three minutes after each set for a muscle building workout.
- Rest for one minute after each set for a toning workout.
- Rest for 30 seconds after each set for a weight loss workout.

Plan to spend the first couple of weeks familiarizing yourself with the equipment and learning the proper form for each exercise.

COOLING DOWN

End each workout with 5 to 10 minutes of stretching. Include stretches for both your arms and legs. Move

slowly as you stretch and do not bounce. Ease into each stretch gradually and go only as far as you can without strain. Stretching at the end of each workout is an effective way to increase flexibility.

STAYING MOTIVATED

For motivation, keep a record of each workout. The chart on page 13 of this manual can be photocopied and used to schedule and record your workouts. List the date, the exercises performed, the weight used, and the numbers of sets and repetitions completed. Record your weight and key body measurements at the end of every month. Remember, the key to achieving the greatest results is to make exercise a regular and enjoyable part of your everyday life.

MUSCLE CHART

- A. Sternomastoid (neck)
- B. Pectoralis Major (chest)
- C. Biceps (front of arm)
- D. Obliques (waist)
- E. Brachioradials (forearm)
- F. Hip Flexors (upper thigh)
- G. Abductor (outer thigh)
- H. Quadriceps (front of thigh)
- I. Sartorius (front of thigh)
- J. Tibialis Anterior (front of calf)
- K. Soleus (front of calf)
- L. Rectus Abdominus (stomach)
- M. Adductor (inner thigh)
- N. Trapezius (upper back)
- O. Rhomboideus (upper back)
- P. Deltoid (shoulder)
- Q. Triceps (back of arm)
- R. Latissimus Dorsi (mid back)
- S. Spinae Erectors (lower back)
- T. Gluteus Medius (hip)
- U. Gluteus Maximus (buttocks)
- V. Hamstring (back of leg)
- W. Gastrocnemius (back of calf)

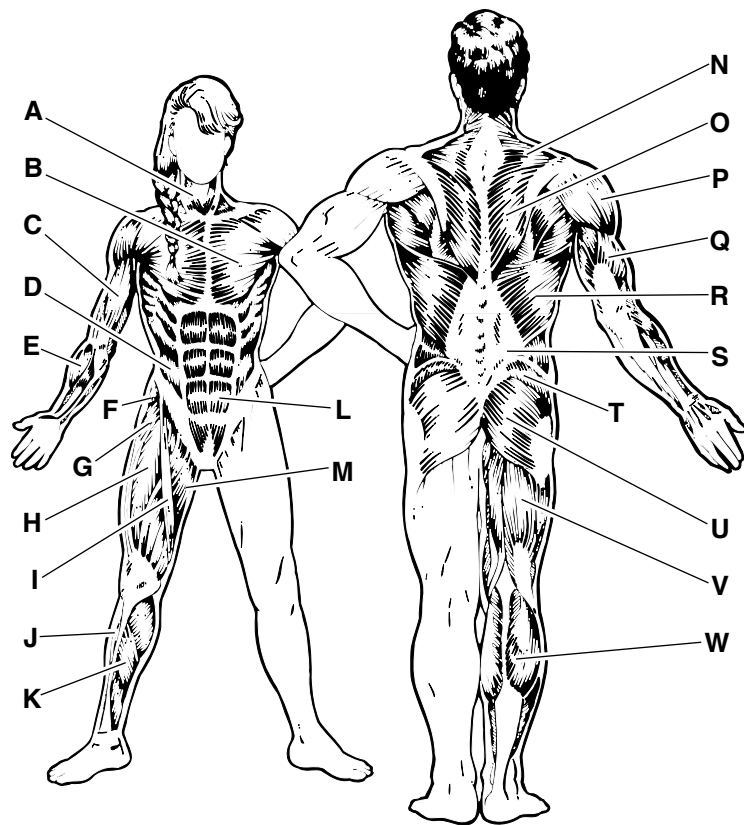

MONDAY	EXERCISE	WEIGHT	SETS	REPS
Date: _____ / _____ / _____				

TUESDAY AEROBIC EXERCISE

Date: _____ / _____ / _____

WEDNESDAY	EXERCISE	WEIGHT	SETS	REPS
Date: _____ / _____ / _____				

THURSDAY AEROBIC EXERCISE

Date: _____ / _____ / _____

FRIDAY	EXERCISE	WEIGHT	SETS	REPS
Date: _____ / _____ / _____				

Make photocopies of this page for scheduling and recording your workouts.

PART LIST—Model No. RBBE14210

R1101A

Key No.	Qty.	Description	Key No.	Qty.	Description
1	1	Frame	25	2	Pad Tube
2	1	Front Stabilizer	26	2	Plastic Plate
3	1	Crossbar	27	4	M10 Washer
4	2	Upright	28	2	M10 x 78mm Bolt
5	1	50mm Round Inner Cap	29	1	Small Adjustment Knob
6	1	Seat Frame	30	1	Backrest Adjustment Knob
7	1	Seat	31	2	M6 x 16mm Bolt
8	1	Backrest	32	10	8mm Bushing
9	1	Backrest Bracket	33	2	12.5mm Spacer
10	2	Backrest Frame	34	10	M10 x 95mm Bolt
11	1	Left Weight Spotter	35	17	M10 Nylon Locknut
12	1	Left Weight Rest	36	2	M10 x 65mm Bolt
13	1	Leg Lever Bracket	37	2	M10 x 140mm Bolt
14	1	Seat Bracket	38	1	M10 x 100mm Bolt
15	1	Leg Lever	39	5	M6 x 50mm Bolt
16	8	Square Bushing	40	4	M8 x 55mm Carriage Bolt
17	2	Upright Cap	41	1	40mm x 50mm Inner Cap
18	4	Large Adjustment Knob	42	4	M8 Nylon Locknut
19	5	M6 Washer	43	4	20mm x 40mm Inner Cap
20	5	75mm x 50mm Inner Cap	44	1	Right Weight Rest
21	4	Support Plate	45	1	Right Weight Spotter
22	5	50mm Square Inner Cap	#	1	User's Manual
23	4	Foam Pad	#	1	Exercise Guide
24	4	19mm Round Inner Cap			

“#” Indicates a non-illustrated part. Specifications are subject to change without notice. See the back cover for information on ordering replacement parts.

EXPLODED DRAWING—Model No. RBBE14210

R1101A

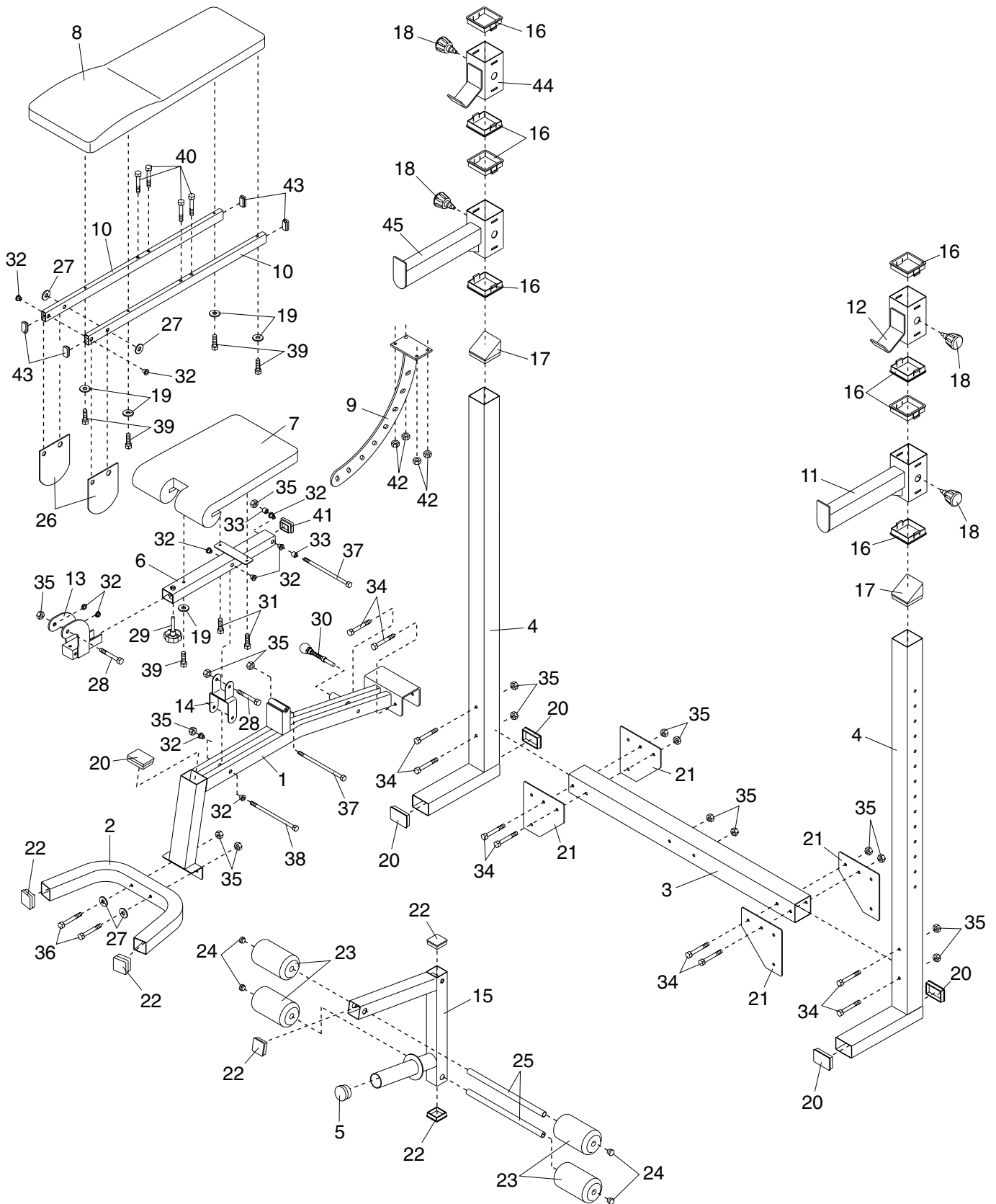

ORDERING REPLACEMENT PARTS

To order replacement parts, simply call our Customer Service Department toll-free at 1-800-999-3756, Monday through Friday, 6 a.m. until 6 p.m. Mountain Time (excluding holidays). To help us assist you, please be prepared to give the following information when calling:

- The MODEL NUMBER of the product (RBBE14210)
- The NAME of the product (REEBOK® RST250 weight bench)
- The SERIAL NUMBER of the product (see the front cover of this manual)
- The KEY NUMBER and DESCRIPTION of the desired part(s) (see the PART LIST and the EXPLODED DRAWING on pages 14 and 15).

LIMITED WARRANTY

ICON Health & Fitness, Inc. (ICON), warrants this product to be free from defects in workmanship and material, under normal use and service conditions, for a period of ninety (90) days from the date of purchase. This warranty extends only to the original purchaser. ICON's obligation under this warranty is limited to replacing or repairing, at ICON's option, the product at one of its authorized service centers. All products for which warranty claim is made must be received by ICON at one of its authorized service centers with all freight and other transportation charges prepaid, accompanied by sufficient proof of purchase. All returns must be pre-authorized by ICON. This warranty does not extend to any product or damage to a product caused by or attributable to freight damage, abuse, misuse, improper or abnormal usage or repairs not provided by an ICON authorized service center, products used for commercial or rental purposes, or products used as store display models. No other warranty beyond that specifically set forth above is authorized by ICON.

ICON is not responsible or liable for indirect, special or consequential damages arising out of or in connection with the use or performance of the product or damages with respect to any economic loss, loss of property, loss of revenues or profits, loss of enjoyment or use, costs of removal, installation or other consequential damages of whatsoever nature. Some states do not allow the exclusion or limitation of incidental or consequential damages. Accordingly, the above limitation may not apply to you.

The warranty extended hereunder is in lieu of any and all other warranties and any implied warranties of merchantability or fitness for a particular purpose is limited in its scope and duration to the terms set forth herein. Some states do not allow limitations on how long an implied warranty lasts. Accordingly, the above limitation may not apply to you.

This warranty gives you specific legal rights. You may also have other rights which vary from state to state.

ICON HEALTH & FITNESS, INC., 1500 S. 1000 W., LOGAN, UT 84321-9813

Free Manuals Download Website

<http://myh66.com>

<http://usermanuals.us>

<http://www.somanuals.com>

<http://www.4manuals.cc>

<http://www.manual-lib.com>

<http://www.404manual.com>

<http://www.luxmanual.com>

<http://aubethermostatmanual.com>

Golf course search by state

<http://golfingnear.com>

Email search by domain

<http://emailbydomain.com>

Auto manuals search

<http://auto.somanuals.com>

TV manuals search

<http://tv.somanuals.com>