

RIGID

®

JP0610 OPERATOR'S MANUAL

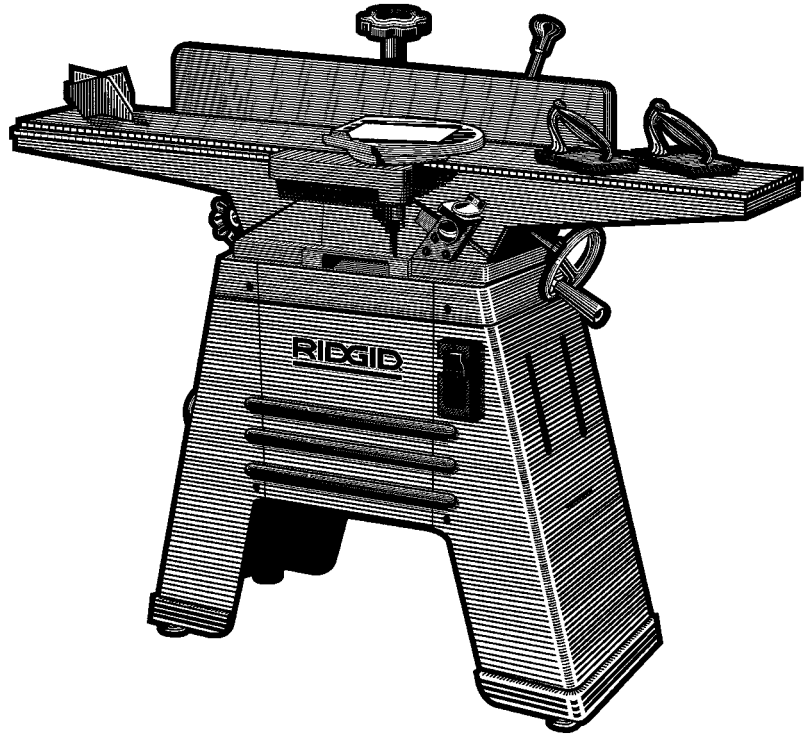

**6-1/8" (156mm) JOINTER/
PLANER**

⚠ WARNING: To reduce the risk of injury, the user must read and understand the operator's manual before using this product.

Part No. SP6442

**SAVE THIS MANUAL FOR
FUTURE REFERENCE**

Table of Contents

Section	Page	Section	Page
Table of Contents	2	Cutter Head Guard Functional Check	19
Safety Instructions For Jointer/Planer	2	Adjusting Guard Spring	19
Safety Symbols	2	Adjusting the Leveling Feet	19
Major Hazards	3	Getting to Know Your Jointer/Planer	20
Before Using the Jointer/Planer	3	Alignments	22
Safety Labels and Indicators on the Jointer/Planer ...	4	Cutter Knife Alignment/Adjustments	22
When Installing Or Moving the Jointer/Planer	4	Cutter Knife Sharpening	23
Before Each Use	4	Outfeed Table Adjustment	24
To Reduce the Risk of Injury From Jams, Slips Or		Adjusting Table Gibs	25
Thrown Pieces (Kickbacks Or Throwbacks)	5	Angle Gauge Use	25
Plan Ahead To Protect Your Eyes, Hands,		Fence Tilt Use and Bevel Stop Adjustment	25
Face and Ears	5	Safety Instructions for Basic Jointer/Planer	
Inspect Your Workpiece	5	Operation	26
Whenever Jointer/Planer Is Running	6	Before Each Use.....	26
Before Leaving the Jointer/Planer	6	Feeding the Workpiece (All Operations)	27
Glossary of Terms for Woodworking	6	To Reduce the Risk of Injury From Jams, Slips Or	
Motor Specifications and Electrical Requirements	7	Thrown Pieces (Kickbacks Or Throwbacks)	27
Power Supply and Motor Specifications	7	Plan Ahead to Protect Your Eyes, Hands,	
General Electrical Connections	8	Face and Ears	28
110-120 Volt, 60 Hz. Tool Information	8	Whenever Jointer/Planer Is Running	28
Changing Motor Voltage	8	Basic Jointer/Planer Cutting Operations	29
Motor Safety Protection	9	Depth of Cut Handwheel Operation	29
Wire Sizes	9	Stop Pin Operation	29
Unpacking and Checking Contents	10	Feeding the Workpiece	29
Tools Needed	10	Planing	30
Unpacking	10	Jointing	30
List of Loose Parts	10	Beveling/Chamfering	30
Loose Parts	11	Rabbeting	31
Loose Parts (From Hardware Pack)	12	Stop Pin Operation	31
Assembly	13	Support Long Workpieces	31
Cabinet and Motor Mount Assembly	13	Using the Hold-Down/Push-Blocks	31
Install the Leveling Feet	14	Sliding Fence Operation	32
Mounting the Motor	14	Maintenance and Lubrication	33
Mounting Jointer Table to Cabinet	15	Maintenance	33
Tensioning Belt and Installing Rear Panel		Lubrication	33
and Pulley Guard	15	Wiring Diagram	33
Installing Handwheel	16	Troubleshooting Guide	34
Attach Sawdust Chute	17	General	34
Adjusting Table Extension	17	Motor	35
Assemble Fence To Bed	18	Repair Parts	36
Install Cutter Head Guard	18		

Safety Instructions For Jointer/Planer

The purpose of safety symbols is to attract your attention to possible dangers. The safety symbols, and the explanations with them, deserve your careful attention and understanding. The safety warnings do not by themselves eliminate any danger. The instructions or warnings they give are not substitutes for proper accident prevention measures.

Safety Symbols

⚠ DANGER: indicates an imminently hazardous situation which, if not avoided, will result in death or serious injury.

⚠ WARNING: indicates a potentially hazardous situation which, if not avoided, could result in death or serious injury.

⚠ CAUTION: indicates a potentially hazardous situation which, if not avoided, may result in minor or moderate injury. It may also be used to alert against unsafe practices that may cause property damage.

NOTE: Advises you of information or instructions vital to the operation or maintenance of the equipment.

Safety Instructions For Jointer/Planer (continued)

▲ WARNING: Do not attempt to use the tool until you have read thoroughly and understand completely the operator's manual. Pay close attention to the safety rules, including Dangers, Warnings, and Cautions. If you use this tool properly and only for what it is intended, you will enjoy years of safe, reliable service.

Major Hazards

All of the safety information and cutting steps are critical to the safe operation of the jointer/planer.

1. Workpiece kickback

Kickback is the uncontrolled grabbing and throwing of the workpiece during jointing or planing. If kickback occurs, the workpiece can hit you or a bystander hard enough to cause broken bones, internal organ injury or death. To reduce or prevent kickback, read and follow the safety information in the Jointing and Planing sections of the manual.

2. Kickback followed by blade contact

Your fingers or hand can contact the blade following kickback if your hands are unprotected or too near the cutter blades. Your fingers can be cut off. To reduce the risk of contacting the cutting blades, read and follow the safety information in the Jointing and Planing sections of the manual.

3. Wrong way feed

Wrong way feed is feeding the workpiece into the cutter blades in the direction of blade rotation. The workpiece can be grabbed by the blades and pull your hands into the blades before you can let go or pull back. Fingers can be cut off. To reduce the risk of wrong way feed, always feed the workpiece against the direction of blade rotation. Cutter blade rotation is shown on the sliding fence guard (behind the center of the fence).

4. Thrown workpiece, chips and cutter blade pieces

The jointer/planer can throw the workpiece, workpiece chips, or pieces of loose or broken cutter blades. You can be blinded. Wear safety goggles labelled "ANSI Z87.1" (or in Canada CSA Z94.3-99) on the package.

▲ DANGER: Follow the steps listed below to reduce or eliminate the risk of being injured when using the jointer/planer. Failure to do so can result in a life threatening injury or death.

1. Lock the fence lock knob.
2. Set the depth of cut per pass to less than 1/8" for jointing and less than 1/32" for planing.
3. Check the blade guard for proper position and smooth operation.
4. Keep hands as far away from the cutters as possible when jointing or planing.
5. Use push blocks or push sticks whenever possible.
6. Complete the cut without stopping or backing up the workpiece.
7. Read and follow the safety information and safety instructions in the operator's manual and in the safety labels on the jointer/planer.
8. Know location and function of all controls before using tool. See "Getting to know your Jointer/Planer" section of this manual.

Before Using the Jointer/Planer

▲ WARNING: Some dust created by power sanding, sawing, grinding, drilling, and other construction activities contains chemicals known (to the State of California) to cause cancer, birth defects or other reproductive harm. Some examples of these chemicals are:

- Lead from lead-based paints,
- Crystalline silica from bricks and cement and other masonry products, and
- Arsenic and chromium from chemically-treated lumber.

Your risk from these exposures varies, depending on how often you do this type of work. To reduce your exposure to these chemicals: work in a well ventilated area, and work with approved safety equipment, such as those dust masks that are specially designed to filter out microscopic particles.

▲ WARNING: To reduce the risk of mistakes that could cause serious, permanent injury, do not plug the jointer/planer in until the following steps have been satisfactorily completed.

Know and Understand the Jointer/Planer

- Completely assemble and align jointer/planer.
- Learn the use and function of the ON-OFF switch, fence slide locking handle, cutter guard, depth of cut hand wheel, locks and stops, fence bevel lock handle, outfeed table, infeed table and hold-down/push-blocks.
- Review and understand all safety instructions and operating procedures in this manual.
- Review the maintenance methods for this jointer/planer.

Safety Instructions For Jointer/Planer (continued)

- Find and read the following warning labels found on the jointer/planer:

▲WARNING	▲ADVERTENCIA	▲AVERTISSEMENT
Turn power off, remove switch, and unplug tool before clearing dust chute.	Apague la herramienta, retire el interruptor y desconecte la herramienta antes de despejar el vertedero de aserrín.	Eteindre l'outil et le débrancher avant de nettoyer l'éjecteur de sciure.

▲WARNING	▲ADVERTENCIA	▲AVERTISSEMENT
<ol style="list-style-type: none"> To reduce the risk of injury, read and understand the operator's manual before using jointer/planer. Wear eye protection marked to comply with ANSI Z87.1, or in Canada CSA Z94.3, 2-89 standards. Always keep the cutter head and drive guards in place and in proper operating condition. Do not remove the guard for rabbeting operations. Never make jointing, planing, or rabbeting cut deeper than 1/8". Always use push blocks for jointing material narrower than 3 inches or planing material thinner than 3 inches. Never perform jointing, planing, or rabbeting cuts on workpieces shorter than 12 inches in length. Turn power off and wait for knives to stop before adjusting or servicing. Do not expose to rain or use in damp locations. Plug power cord into a properly grounded outlet protected by a 15 amp circuit breaker or time delay fuse. In Canada use time delay fuse marked "TD". When servicing, use only identical replacement parts. 	<ol style="list-style-type: none"> Para reducir el riesgo de lesiones, lea y comprenda el manual del operador antes de utilizar jointer/planadora. Portez des lunettes de protection conformes à la norme CSA Z94.3-89. Toujours garder les gardes de tête de coupe et d'entraînement en place et en bon état de fonctionnement. Ne pas retirer la garde pour les de feuillure. Ne jamais utiliser une profondeur de coupe de plus de 3 mm (1/8 po) pour le jointage, le rabotage ou la feuillure. Servez-vous toujours des blocs-poussoir lorsque vous déposez des pièces de moins de 3 pouces d'épaisseur ou de largeur. Ne jamais raboter, dégauchir ou faire de feuillure sur des pièces de moins de 12 pouces de long. Attendez que l'outil cesse de tourner avant d'effectuer des réglages ou des réparations. N'exposez pas l'outil à la pluie et ne l'utilisez pas dans un endroit humide. Branchez sur une prise correctement reliée à la terre et protégée par un disjoncteur ou un fusible à retardement de 15 amp. Au Canada, utilisez les fusibles à retardement repérés "D". À la dar service, utilisez exclusivement des pièces identiques à celles d'origine pour les réparations. 	

Safety Labels and Indicators on the Jointer/Planer

The following labels and indicators are on your jointer/planer. Locate, read and follow the safety instructions and information contained in these labels.

- Safety instruction label on the top of the guard.
- Cutter rotation indicator is on top of the fence holder.
- Cutter position indicator is on top of the fence.
- Safety instruction label below dust chute.

Push blocks and push sticks

Two plastic push blocks are supplied with your jointer/planer. Use them when practical. The rubber sole of the push blocks give better traction with the wood than your hands do. If they become slippery, they can be cleaned with rubbing alcohol, paint thinner or sandpaper.

▲ CAUTION: Use rubbing alcohol or paint thinner only as described on their containers. Use only in well ventilated areas away from open flames, sparks or heat sources to prevent serious personal injury.

Push blocks can't always be used. With larger workpieces, you may have better control of the workpiece using your hands. Always make a test pass first to determine which method gives you better control.

Before you make any cut, plan your hand positions. If a kick-back should occur, plan so that your hands will not fall or be forced into the cutters.

Three Inch Rule (3")

Generally, if your hands are closer than three inches to the blade as you feed the wood, use push blocks. This gives extra protection to your hands by placing the push blocks between your hands and the cutters.

Always Use Push Blocks When Planing, Beveling Or Chamfering

When **jointing**, test for workpiece stability before actually jointing, and use push blocks when you can without sacrificing control.

When Installing Or Moving the Jointer/Planer

Reduce the Risk of Dangerous Environment.

- Use the jointer/planer in a dry, indoor place protected from rain.
- Keep work area well lit.

To reduce the risk of injury from unexpected jointer/planer movement.

- Bolt or clamp the jointer/planer to firm level surface where there is plenty of room for moving the workpiece through the entire cut.
- Support the jointer/planer so the tables are level and the jointer/planer does not rock.
- Put the jointer/planer where neither operators nor bystanders must stand in line with the wood while planing or jointing it.

Before Each Use

Inspect your jointer/planer.

▲ WARNING: The 2-1/2 inch jointer/planer pulley and the 3-1/2 inch motor pulley furnished will run the cutter head at about 5000 RPM when used with a 3450 RPM motor. Use of different types of pulleys or motors will change this speed and could cause jamming, binding, kickback, thrown knives or other dangers.

- To reduce the risk of injury from electrical shock, make sure your fingers do not touch the plug's metal prongs when plugging in or unplugging the jointer/planer.
- Turn off and unplug the jointer/planer before moving it to a new area. To reduce the risk of back injury, get help when you need to lift or move the jointer/planer.
- Bolt the jointer/planer to the floor if it tends to slip, walk, slide or tip over. Be especially aware of movement when jointing/planing long heavy boards.
- Never Stand On Tool.** Serious injury could occur if the tool tips or you accidentally hit the cutter head. Do not store anything above or near the tool where anyone might stand on the tool to reach them.

- To reduce the risk of injury from accidental starting, turn the switch off, unplug the jointer/planer, and remove the switch key before moving the cutter head guard, changing the blades, changing the set, or adjusting anything.
- Check for alignment of moving parts, binding of moving parts, breakage of parts, unit stability, and any other conditions that may affect the way the jointer/planer works.
- Don't force the tool. It will do the job better and safer at the rate for which it was designed.

- If any part is missing, bent or broken in any way, or any electrical part does not work properly, turn the jointer/planer off and unplug the jointer/planer.
- Replace damaged, missing or failed parts before using the jointer/planer again.
- Make sure the cutter guard works properly. With the switch off and key removed, pull the cutter guard open and let go. If the guard doesn't smoothly swing closed, contact an Authorized Service Center.
- Make sure the cutter head turns in the right direction.

The top should move toward the infeed table. If the cutter head turns the wrong direction, contact an Authorized Service Center.

- Keep Jointer/Planer interior free of wood chips and dust buildup around motor and switch box.
- Keep knives sharp. Dull or nicked knives tend to "pound" and chew at the wood, causing kickbacks.
- To reduce the risk of injury from unsafe accessories, use only recommended accessories.

To Reduce the Risk of Injury From Jams, Slips Or Thrown Pieces (Kickbacks Or Throwbacks)

- Use this jointer/planer to cut only wood.
- Use push blocks or push sticks whenever possible.
- Plan your hand placement so your fingers will not be anywhere a sudden slip could cause them to slide or fall into the cutter head. When using only one hold-down/push-block to feed the wood, do not put your other hand on the jointer/planer, workpiece, or hold-down/push-block.
- To reduce the risk of injury from thrown pieces, make sure the knives are sharp, properly installed and the cutter knives wedge screws are tight.
- Make sure the clamps and locks are tight and there is not excessive play in any parts.
- Adjust the depth of cut to between 1/32 and 1/16 of an inch for best results in most operations. A deep cut makes feeding the wood harder and can cause the wood to kickback. To be sure you will make a depth of cut you planned, always lower the infeed table slightly farther than you wanted then, raise the table to the

desired depth.

- Use The Right Tool. Don't force tool or attachment to do a job it was not designed for.

Inspect your work area.

- Keep work area clean.
- Cluttered areas and benches invite accidents.
- Floor must not be slippery from wax or sawdust.
- To reduce the risk of burns or other fire damage, never use the jointer/planer near flammable liquids, vapors or gases.
- Before using the jointer/planer, clear the table of all objects not needed to feed the workpiece.
- To reduce the risk of injury, don't do any layout, assembly, or setup work on the jointer/planer bed.
- Maintain tools with care. Keep tools sharp and clean for best and safest performance. Follow instructions for lubricating and changing accessories.

Plan Ahead To Protect Your Eyes, Hands, Face and Ears

Reduce the Risk of Accidental Starting.

- Make sure switch is "OFF" before plugging jointer/planer into a power outlet.

Dress for safety.

- Any power tool can throw foreign objects into the eyes. This can result in permanent eye damage. Always wear safety goggles (not glasses) complying with ANSI Z87.1 (or in Canada CSA Z94.3-99) shown on package. Everyday eyeglasses have only impact resistant lenses. They are not safety glasses. Safety goggles are available at many local retail stores. Glasses or goggles not in compliance with ANSI or CSA could seriously hurt you when they break.



- For dusty operations, wear a dust mask along with safety goggles.
- Do not wear loose clothing, gloves, neckties or jewelry (rings, wrist watches). They can get caught and draw you into moving parts.
- Wear nonslip footwear.
- Tie back long hair.
- Roll long sleeves above the elbow.
- Noise levels vary widely. To reduce the risk of possible hearing damage, wear ear plugs or muffs when using jointer/planer for hours at a time.

Inspect Your Workpiece

- Make sure there are no nails or foreign objects in the part of the workpiece to be cut.

Plan your cut.

- Small or thin workpieces can kickback when they tip

over on the tables or into the cutter head. To reduce the risk of cutter head contact or workpiece kickback:

- Never joint, plane or bevel workpieces shorter than 12 inches.

Safety Instructions For Jointer/Planer (continued)

- When jointing or rabbeting:
 - Never joint or bevel workpieces less than 3/4 inch wide or 1/4 inch thick.
 - Always use the hold-down/push-blocks when jointing or beveling wood whenever possible.
 - When rabbeting, always make cuts in 1/8" increments or less.
- When planing or beveling:
 - Never plane wood thinner than 1/2 inch.
 - Always use hold-down/push-blocks when planing wood.
 - Never cut **Freehand**. Guide your workpiece solidly against the fence and table top.
 - Make sure there's no debris between the workpiece and its supports.

Use extra caution with large, very small or awkward workpieces.

- Use extra supports (tables, saw horses, blocks, etc.) for any workpiece large enough to tip when not held down to the table top. Never use another person as additional support or to help feed, support or pull the workpiece.
- Never cut more than one workpiece at a time.
- Never turn your jointer/planer "ON" before clearing everything except the workpiece and related support devices off the table.
- Before trying a new or little used operation, carefully plan your hand placement. Make sure you have proper hold-down/push-blocks, jigs, fixtures, stops, etc. ready to use.

Whenever Jointer/Planer Is Running

⚠ WARNING: Don't allow familiarity (gained from frequent use of your jointer/planer) cause a careless mistake. Always remember that a careless fraction of a second is enough to cause a severe injury.

- Before actually cutting with the jointer/planer, let it run for a while. If it makes an unfamiliar noise or vibrates a lot, stop immediately. Turn the jointer/planer off. Unplug the jointer/planer. Do not restart until finding and correcting the problem.

Keep Children Away.

- Keep all visitors a safe distance from the jointer/planer.
- Make sure bystanders are clear of the jointer/planer and workpiece.

Don't Force Tool.

- Let the cutter head reach full speed before cutting.
- Feed the workpiece into the jointer/planer only fast enough to let the tool cut without bogging down or binding.

Before freeing jammed material.

- Turn switch "OFF".
- Wait for all moving parts to stop.
- Unplug the jointer/planer.
- Check knives for sharpness and nicks before starting again.

Before Leaving the Jointer/Planer

- Turn the jointer/planer off.
- Wait for knives to come to a complete stop.
- Unplug the jointer/planer.

- Make workshop child-proof. Lock the shop. Disconnect master switches. Remove the yellow switch key. Store it away from children and others not qualified to use the tool.

⚠ WARNING:



The operation of any power tool can result in foreign objects being thrown into your eyes, which can result in severe eye damage. Before beginning tool operation, always wear safety goggles or safety glasses with side shields and a full face shield when needed. We recommend Wide Vision Safety Mask for use over eyeglasses or standard safety glasses with side shields. Always wear eye protection which is marked to comply with ANSI Z87.1.



Look for this symbol to point out important safety precautions. It means attention!!! Your safety is involved.

SAVE THESE INSTRUCTIONS

Glossary of Terms for Woodworking

Bed

The combination of infeed and outfeed table surfaces which support the workpiece during a cutting operation.

Bevel/Chamfer

Removing wood along the edge of a board to make that edge straight, smooth and angled to the board face which is against the fence.

Cutter Guard

Spring loaded guard or shield covering the cutter head.

Cutter Head

The cutter head is a rotating piece with three adjustable knives. The cutter head removes material from the workpiece

Depth of cut

A term used to indicate how deep into the workpiece the cutter knives will cut.

Fence

The fence is attached to the jointer/planer base. The fence helps support and guide the workpiece as it is pushed across the cutter head.

Freehand

Using the tool without holding the workpiece firmly against the fence and table. This can let the workpiece twist and kick back and must never be attempted.

Gum

A sticky, sap based residue from wood products.

Hold-Down/Push-Blocks

They are required for your own safety. They are used to hold your workpieces against the table and fence when planing, rabbeting or jointing.

Infeed Table

The section of the jointer bed upon which the workpiece is placed before being pushed into the cutter head. Infeed table height is adjustable which allows the operator to select the depth of cut.

Jointing

The removal of wood along the edge of a board so as to make that edge straight, smooth and square to the board face which is against the fence.

Kickback

An uncontrolled grabbing and throwing of the workpiece back toward the operator by the rotating cutter head.

Leading End

The end of the workpiece which is pushed into the cutter head first.

Outfeed Table

The section of a jointer bed which supports the workpiece after it passes over the cutter head.

Planing

Removing wood from the widest surface or face of a board so as to make it flat and smooth.

Rabbet

A notch cut into the edge of workpiece.

Resin

A sticky, sap based substance that has hardened.

Revolutions Per Minute (RPM)

The number of turns completed by a spinning object in one minute.

Throw-Back

Throwing of pieces in a manner similar to a kickback.

Trailing End

The workpiece end last cut by the knives.

Workpiece

The item on which the cutting operation is being performed. The surfaces of a workpiece are commonly referred to as faces, ends and edges.

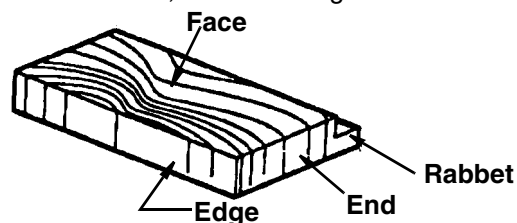

Motor Specifications and Electrical Requirements

Power Supply and Motor Specifications

⚠ WARNING: To reduce the risk of electrical hazards, fire hazards or damage to the tool, use proper circuit protection. Your tool is wired at the factory for operation using the voltage shown. Connect tool to a power line with the appropriate voltage and a 15-amp branch circuit. Use a 15-amp time delay type fuse or circuit breaker. To reduce the risk of shock or fire, if power cord is worn or cut, or damaged in any way, have it replaced immediately.

The A/C motor used on this tool is a capacitor start, non-reversible type, wired at the factory for 110-120V AC, 60 Hz. operation. Follow the instructions on page 8 to connect the motor for 220-240V A/C operation.

Rated Horsepower	1	
Voltage	110-120	220-240
Amperes	12	6
Hertz (Cycles)	60	
Phase	Single	
RPM	3450	
Rotation of Shaft	Counterclockwise	

Motor Specifications and Electrical Requirements (continued)

General Electrical Connections

⚠ DANGER: To reduce the risk of electrocution:

1. Use only identical replacement parts when servicing. Servicing should be performed by a qualified service technician.
 2. Do not use in rain or where floor is wet.
- This tool is intended for indoor residential use only.

⚠ WARNING: Do not permit fingers to touch the terminals of plug when installing or removing the plug to or from the outlet.

If power cord is worn or cut, or damaged in any way, have it replaced immediately.

110-120 Volt, 60 Hz. Tool Information

The plug supplied on your tool may not fit into the outlet you are planning to use. Your local electrical code may require slightly different power cord plug connections. If these differences exist refer to and make the proper adjustments per your local code before your tool is plugged in and turned on.

In the event of a malfunction or breakdown, grounding provides a path of least resistance for electric current to reduce the risk of electric shock. This tool is equipped with an electric cord having an equipment grounding conductor and a grounding plug, as shown. The plug must be plugged into a matching outlet that is properly installed and grounded in accordance with all local codes

and ordinances.

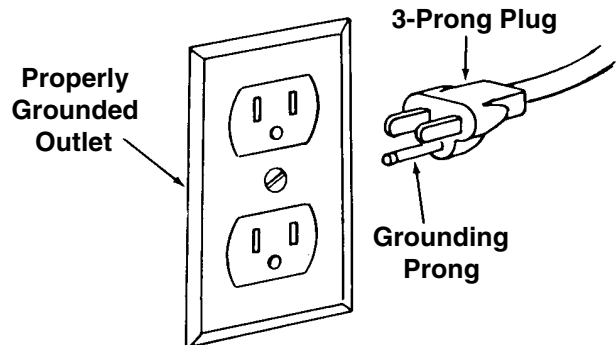

Do not modify the plug provided. If it will not fit the outlet, have the proper outlet installed by a qualified electrician. Improper connection of the equipment grounding conductor can result in a risk of electric shock. The conductor with insulation having an outer surface that is green with or without yellow stripes is the equipment grounding conductor. If repair or replacement of the electric cord or plug is necessary, do not connect the equipment-grounding conductor to a live terminal.

If the grounding instructions are not completely understood, or if you are in doubt as to whether the tool is properly grounded check with a qualified electrician or service personnel.

⚠ WARNING: If not properly grounded, this tool can cause an electrical shock, particularly when used in damp locations, in proximity to plumbing, or out of doors. If an electrical shock occurs there is the potential of a secondary hazard, such as your hands contacting the knives.

Changing Motor Voltage

⚠ WARNING: If not properly grounded, this tool can cause an electrical shock, particularly when used in damp locations, in proximity to plumbing, or out of doors. If an electrical shock occurs there is the potential of a secondary hazard, such as your hands contacting the knives.

NOTE: The jointer is prewired at the factory for 120V operation. Use the following procedure to change motor voltage. To change to 240V application an additional wire nut is supplied from the factory. This part is included in the loose parts.

1. Unplug the jointer/planer before making or changing any connections. Open the motor junction box cover located on the side of the motor.
2. Remove and discard the electrical tape from the wire nuts. Remove wire nuts.

3. Reconnect the leads as shown in the "Wiring Diagram" section at the rear of manual.
4. Reinstall the wire nuts and wrap with two layers of new U.L. listed electrical tape per wire nut.
5. Recheck your wiring to the wiring diagrams. Do this so you can be sure that the wiring is correct.
6. Reinstall the junction box cover.
7. Cut off the 120 volt power cord **plug** and replace it with a (3 blade) 240 volt 15 amp U.L. listed plug. (See illustration of 240V plug & receptacle.) Connect the power cord white and black leads, respectively, to the "hot" plug blade terminals and connect the power cord green grounding wire to the plug ground prong terminal.
8. Plug your jointer into a 220-240V, 15 amp, 3 blade receptacle.

9. Make certain the receptacle is connected to a 240 volt A.C. power supply through a 240 volt branch circuit having at least a 15 amp capacity and protected by a 15 amp time-delay fuse or circuit breaker.

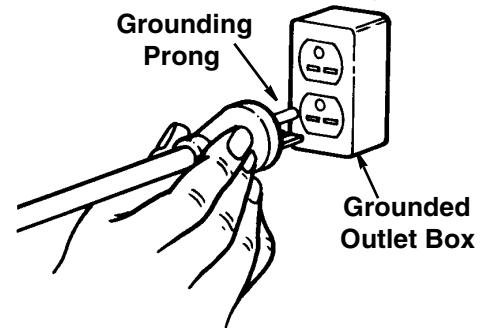
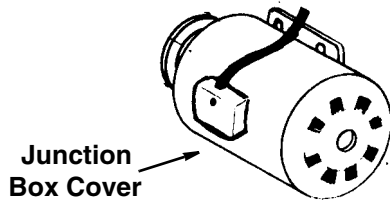

220-240 Volt, 60 Hz. Tool Connections

Motor Safety Protection

IMPORTANT: To reduce the risk of motor damage, this motor should be blown out or vacuumed frequently to keep sawdust from interfering with normal motor ventilation.

1. Connect this tool to a power source with the appropriate voltage for your model and a 15-amp branch circuit with a 15-amp time delay fuse or circuit breaker. Using the wrong size fuse can damage the motor.
2. If the motor won't start, turn off the power switch immediately and unplug the tool. Check the cutter head to make sure it turns freely. If the cutter head is free, try to start the motor again. If the motor still does not start, refer to the "Motor Troubleshooting Chart."
3. Fuses may "blow" or circuit breakers may trip frequently if:

- a. **Motor Is Overloaded**-Overloading can occur if you feed too rapidly or make too many start/stops in a short time.
 - b. Line voltages should not be more than 10% above or below the nameplate voltage. For heavy loads, however, the voltage at motor terminals must equal the voltage specified for your model.
 - c. Improper or dull jointer knives are used.
4. Most motor troubles may be traced to loose or incorrect connections, overload, low voltage (such as small size wire in the supply circuit) or to overly long supply circuit wire. Always check the connections, the load and the supply circuit whenever motor doesn't work well. Check wire sizes and length with the Wire Size Chart.

Wire Sizes

NOTE: Make sure the proper extension cord is used and is in good condition.

The use of any extension cord will cause some loss of power. To keep this to a minimum and to prevent overheating and motor burn-out, use the table shown to determine the minimum wire size (A.W.G.) extension cord.

Use only 3-wire extension cords which have 3-prong grounding type plugs and 3-pole receptacles which accept the tools plug.

Extension Cord Length	Gauge (A.W.G.)	
	110-120V	220-240V
0-25 Ft.	14	16
26-50 Ft.	12	14

Unpacking and Checking Contents

Tools Needed



2 Ft. Straight Edge

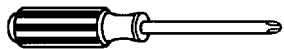

Phillips Screwdriver

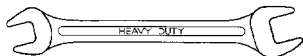

1/2" Open End Wrench



Adjustable Wrench

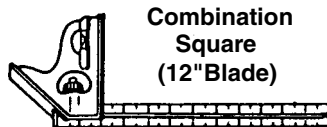

Combination Square
(12" Blade)



5/16" Hex "L" Wrench

Combination square must be true. Check its accuracy as shown

Select the straight edge of a board.
This edge must be perfectly straight.

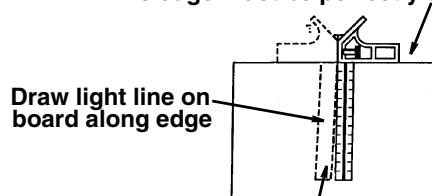

Draw light line on board along edge

Should be no gap or overlap here when square is flipped over in dotted position

Unpacking

⚠ WARNING: To reduce the risk of injury from unexpected starting or electrical shock, do not plug the power cord into a power source outlet during unpacking, until all assembly steps are complete, and you have read and understand the safety and operating instructions.

⚠ WARNING: This tool is heavy. To reduce the risk of back injury, get help whenever you have to lift the tool.

Your jointer/planer is shipped complete in one carton and includes a steel cabinet.

1. Remove the parts from the carton. Lift the bed assembly at the bottom of the base.
2. Place the tool on a secure, stationary work surface and look it over carefully.
3. Separate all parts from packing materials and check each one with the "Table of Loose Parts" and the "List of Loose Parts" to make certain all items are accounted for before discarding any packing material.

If you are missing any parts, check packing material for those items.

⚠ WARNING: If any parts are missing, do not attempt to assemble the jointer/planer. Do not plug in the power cord or turn the switch on until the missing parts are obtained and are installed correctly.

4. Contact an Authorized Service Center to get the miss-

ing parts. Use the "Repair Parts" pages at the end of this manual to identify the part number of the missing parts after completing the "Unpacking and Checking Contents" section.

⚠ WARNING: The cutting knives are extremely sharp. Do not touch the cutter knives to prevent serious injury.

5. The top of the table and the front of the fence are covered with a protective coating. These surfaces must be cleaned before using the jointer/planer. Clean these surfaces with a general purpose solvent, such as mineral spirits. Water will rust the surfaces. Do Not use water, soapy water or water based cleaners.

⚠ WARNING: Use solvents according to the instructions on their package. Use only in well ventilated areas, away from flames, sparks or heat sources. Do not use solvents in closed areas to prevent serious injury.

Protect the exposed surfaces with wax. Paste wax or automotive wax are both good for this job. The wax will protect the surface from rust and will make it easier to slide the wood along the table and fence. Automotive wax is best as it will not rub off on the wood.

6. Wipe all parts thoroughly with a clean, dry cloth.

List of Loose Parts

NOTE: Before beginning assembly, check that all parts are included. If you are missing any part, do not assemble the tool. Call 1-866-5391710 to get the missing part. Sometimes small parts can get lost in packaging material. Do not throw away any packaging until jointer/planer is put together. Check packaging for missing parts before contacting RIDGID. A complete parts list (Repair Parts) is at the end of the manual. Use the list to identify the number of the missing part.

The following parts are included:

Item	Part Name	Qty.
A	Jointer Bed Assembly	1
B	Fence Assembly	1
C	Motor Assembly w/Switch	1
D	Motor Mount Bracket	1
E	Sawdust Chute	1

F	Left Side Panel	1
G	Right Side Panel	1
H	Front Panel	1
J	Rear Panel	1
K	Pulley Guard	1
L	V-Belt	1
M	Angle Gauge	1
N	Cutter Guard	1
P	Handwheel	1
Q	Fence Lock Knob	1
R	Fence Tilt Knob	1
S	Push Blocks	2
T	Operator's Manual	1
U	Hardware Pack	*

* Quantity of hardware pack may vary.

Loose Parts

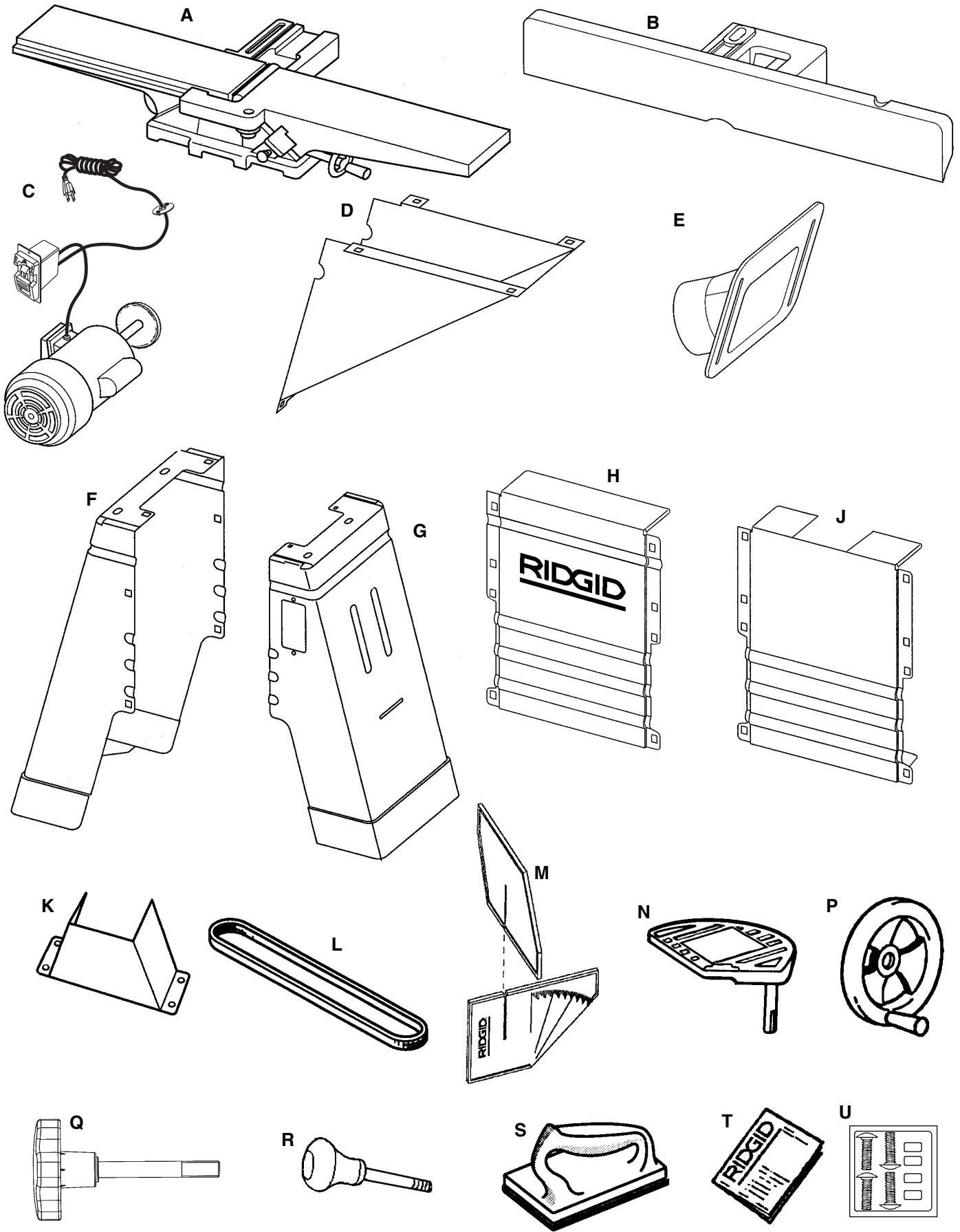

Unpacking and Checking Contents (continued)

Loose Parts (From Hardware Pack)



Wrench Hex-"L" 3mm (1)



Wrench Box 8mm/10mm (1)



Wire Nut (1)



Switch Key (1)

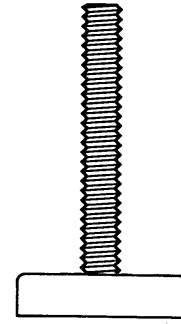

Leveling Feet (4)

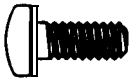

Screw Pan Head (1)
w/Washer 1/4-20 x 5/8

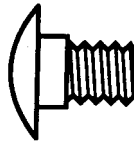

Carriage Head Bolt (22)
5/16-18 x 1/2"

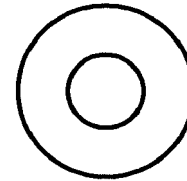

Washer (8)
3/8"

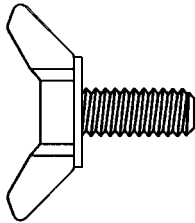

Screw Wing w/Washer
1/4-20 x 1/2 (2)

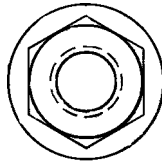

Serrated Flange
Hex Nut (22)
5/16-18

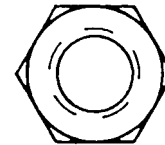

Hex Nut (8)
3/8-16

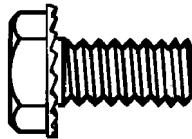

Serrated Hex Bolt (3)
3/8-16 x 3/4"

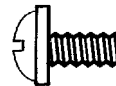

Screw Pan Head Cr Serr (6)
(Machine Screw w/Washer Head)
3/16-24 x 3/8

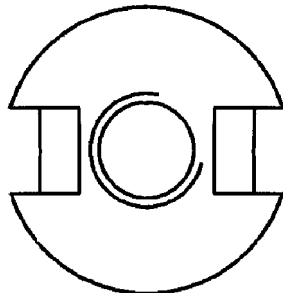

T-Nut (1)

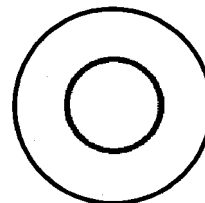

Washer (1)
1/2"

These two parts are together in hardware pack

Assembly

⚠ WARNING: This tool is heavy. To reduce the risk of back injury, get help whenever you have to lift the tool.

Cabinet and Motor Mount Assembly

- From the hardware pack find the following:
 - 6 Carriage Head Bolts 5/16-18 x 1/2"
 - 6 Serrated Flange Hex Nut 5/16From among the loose parts find the following:
 - Left Panel Side
 - Right Panel Side
 - Motor Mount
- Mount the motor mount onto the left side panel as shown. Make sure the lower tab of the motor mount with two holes is on the inside of the left side panel. Bolt the motor mount to the panel using the 5/16 carriage head bolts and 5/16 serrated flange nuts. Tighten the nuts with a wrench.
- Mount the right side panel to the motor mount as shown using two 5/16 carriage head bolts and 5/16 serrated flange nuts. Tighten the nuts with a wrench.
- From the hardware pack find the following:
 - 6 Carriage Head Bolts 5/16-18 x 1/2"
 - 6 Serrated Flange Hex Nuts 5/16From among the loose parts find the following:
 - 1 Front panel with RIDGID label
- Bolt the front panel in place as shown using six 5/16 carriage head bolts and six 5/16 serrated flange nuts. Make sure the front panel is mounted on the same side of the base as the switch opening. The panel should bolt in place on the backside of the left and right side panels as shown. Tighten the nuts with a wrench.
- Tighten all bolts on the base at this time.
NOTE: It may be easier to tighten the bolt holding the front panel on if the base is turned on its side. The rear panel will be mounted later.
NOTE: Holes marked "A" on both front and rear panels are not used for assembly.

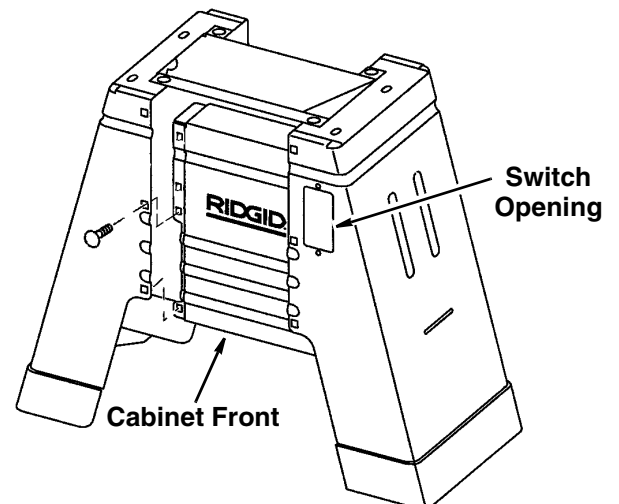
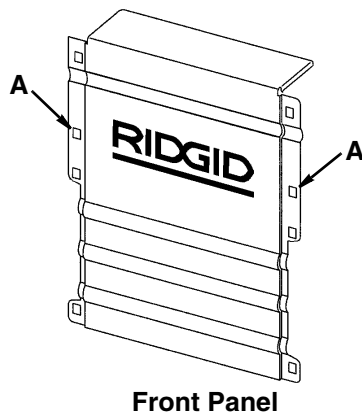
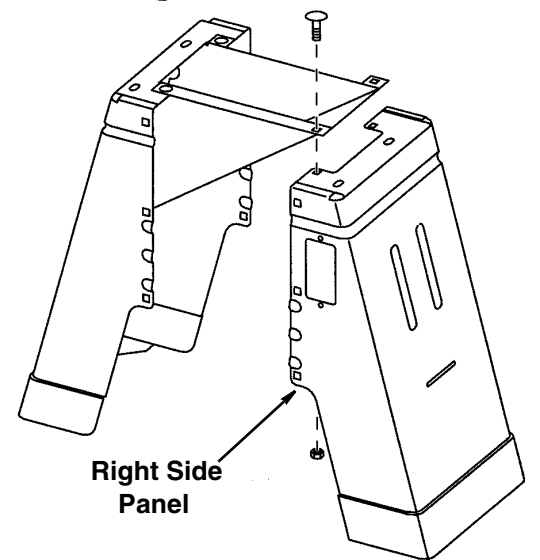
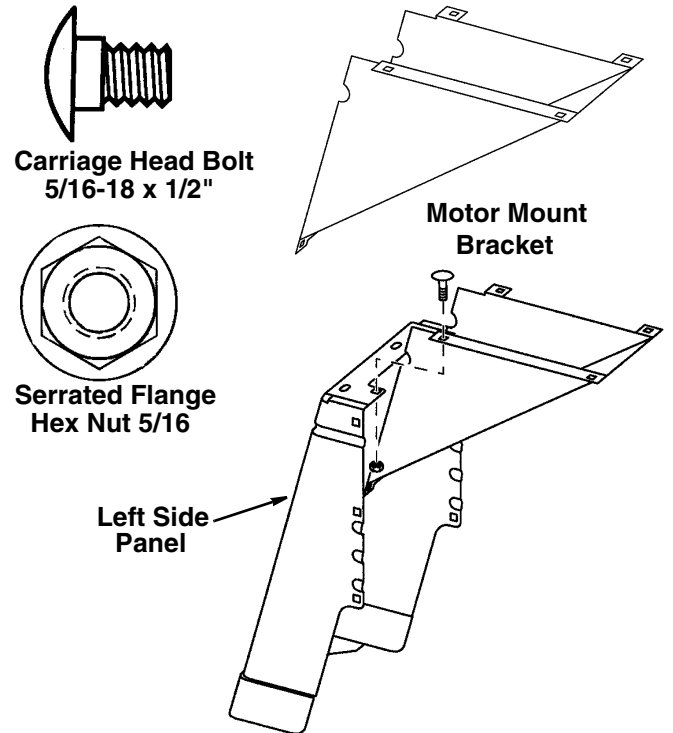

Assembly (continued)

Install the Leveling Feet

1. Turn the base upside down.
2. From the hardware pack find the following:
 - 4 Rubber Leveling Feet
 - 8 Flat Washer 3/8
 - 8 Hex Nut 3/8
3. Thread one 3/8 nut onto each of the leveling feet until the nut is 1/2" from the foot. Do this for all four feet.
4. Attach the leveling feet as shown. Place one 3/8 washer on the bottom side of the foot mount tab and one washer on top. Bolt the feet in place with the second 3/8 nut. Tighten the nuts down with a wrench.

NOTE: Once the jointer is in its permanent location the leveling feet may need to be adjusted.

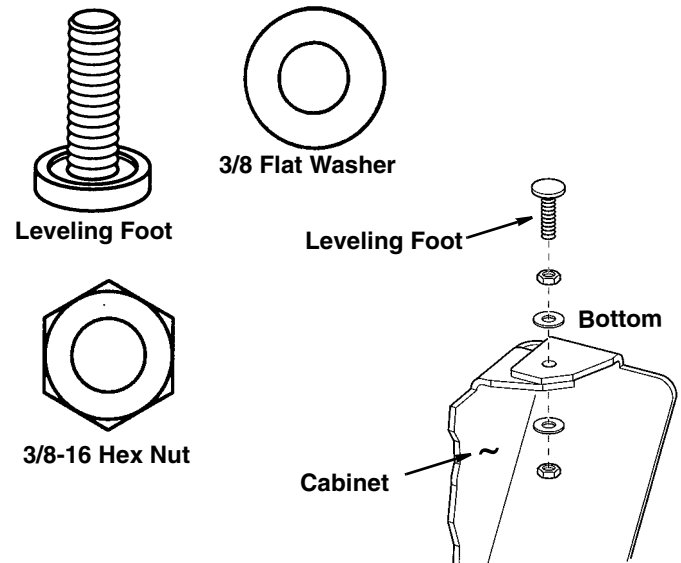

Mounting the Motor

1. Turn the cabinet upside down and place a 4 x 4 block under the right side of the cabinet so the base is tilted as shown. This will elevate the motor mount so it is level with the floor making assembly easier.
2. From the hardware pack find the following:
 - 4 Carriage Head Bolts 5/16-18 x 1/2"
 - 4 Serrated Flange Hex Nuts 5/16
 - 2 Machine Screws with Washer Head 3/16"From among the loose parts find the following:
 - 1 Motor and Switch Assembly
3. Place the motor on the motor mount as shown. Make sure the motor shaft faces the rear of the cabinet (away from the side with RIDGID label).
4. Bolt the motor to the motor mount using the four 5/16 carriage head bolts and four 5/16 serrated flange nuts. The bolts should be placed through the motor mount into the motor bracket as shown. Do not tighten the bolts at this time.
5. Using the two 3/16 screws, mount the switch into place as shown. Make sure the switch is right side up.

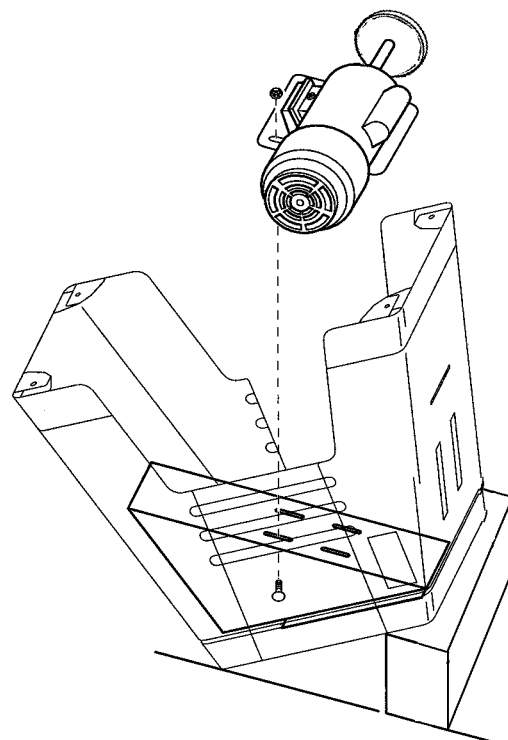
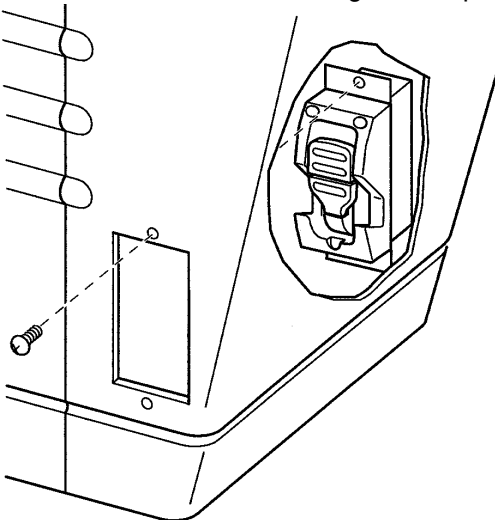
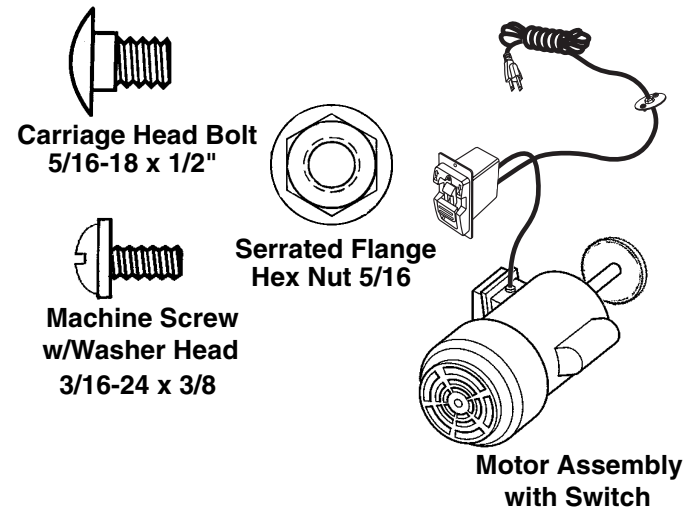

Mounting Joints Table to Cabinet

⚠ WARNING: This tool is heavy. To reduce the risk of back injury, get help whenever you have to lift the tool.

1. With help place the bed assembly upside down on two blocks as shown.
2. Place the jointer cabinet on top of the bed assembly as shown.
3. From the hardware pack find the following:
3 Serrated Hex Head Bolts 3/8-16 x 3/4"
From among the loose parts find the following:
V-belt
4. Bolt the table to the cabinet using the 3 hex head bolts and tighten all three bolts. To access third bolt, reach into dust collection port on left side.
5. Slip the belt over both the motor and cutterhead pulleys.

Tensioning Belt and Installing Rear Panel

1. While the jointer is still upside down slide the motor up the motor mount to put tension on the belt. This will require assistance. Once the belt has been tensioned tighten the motor bolts. The belt should have approximately 1" deflection (the measurement of how much you can push in on one side of the belt).

NOTE: An alternate method for tensioning the belt is to turn the unit upright, letting the motor slide down in the slots and allowing the weight of the motor only to tension the belt.

2. Visually check the front to back alignment of the pulleys and adjust the motor as needed.
3. From the hardware pack locate the following:
6 Carriage Head Bolts 5/16-18 x 1/2"
6 Serrated Flange Hex Nuts 5/16"
From among the loose parts find the following:
Rear Cabinet Panel
4. Position the rear panel in place from the bottom of the cabinet as shown. Bolt in place using the six 5/16 carriage head bolts and six 5/16 serrated flange nuts. Make sure the rear panel is on the inside of the cabinet side. Tighten the nuts.
5. Thread the power cord through the hole in the rear of the cabinet.

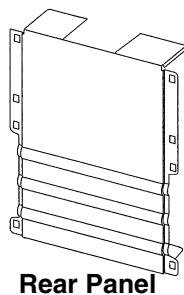

6. Remove the screws and washers from the cable plate.
7. Thread the power cord through the hole from the inside of the cabinet until the cord plate reaches the cabinet.
8. Reinstall the washers and screws from the outside of the cabinet with the cord plate flush against the inside of cabinet. Retighten screws.

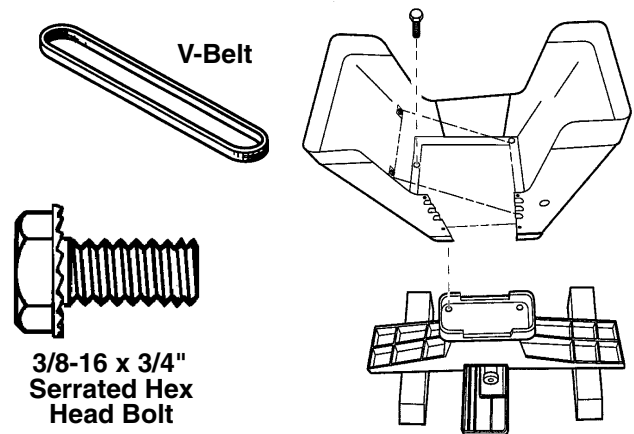

NOTE: Motor mount and motor removed for clarity

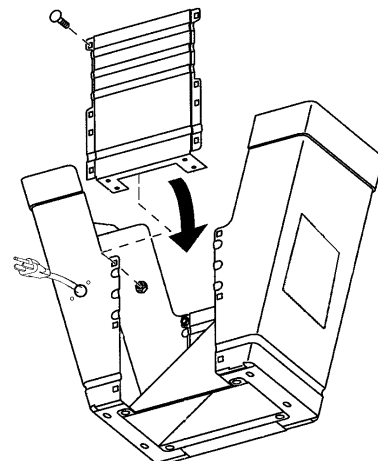
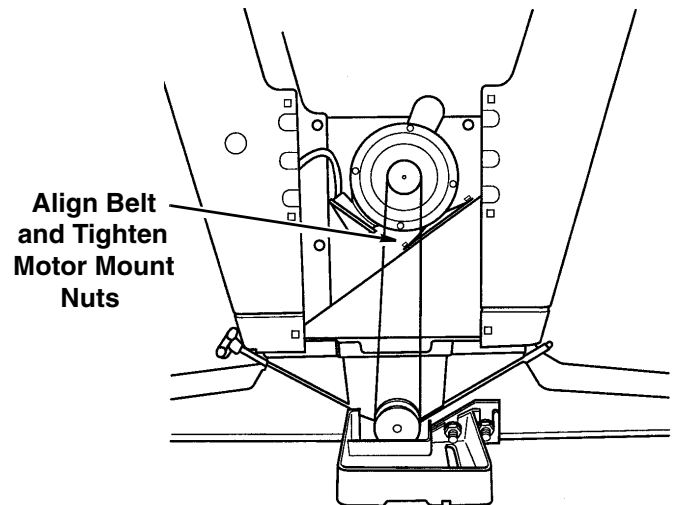

Assembly (continued)

Installing the Pulley Guard

1. From the hardware pack locate the following:
From among the loose parts find the following:
 - 4 Pan Head Cross Serrated Screws 3/16-24 x 3/8"
Belt Guard
2. With assistance set the jointer upright.
3. Mount the belt guard in place as shown using the four 3/16" screws.



Screw Pan Head Cr
Serr 3/16-24 x 3/8"

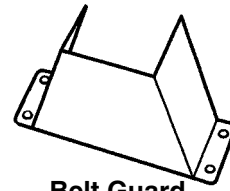

Belt Guard

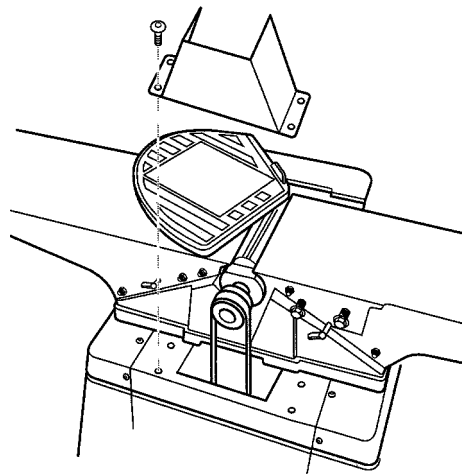

NOTE: Fence mount removed for clarity

Installing Handwheel

1. From the hardware pack find the following:
 - 1 Screw Pan Head 1/4-20 x 5/8
 - 1 Washer 1/4
2. From among the loose parts find the following:
 - 1 Handwheel
3. Slip the handwheel onto the infeed table elevation shaft and install the washer and screw as shown.



Handwheel

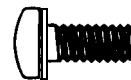

Screw Pan Head w/Washer
1/4-20 x 5/8"

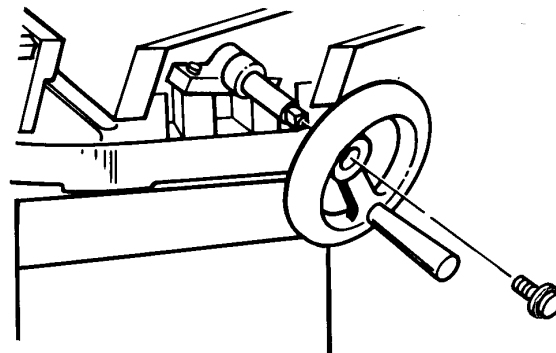

Attach Sawdust Chute

1. From among the loose parts find the following:
 - 1 Sawdust Chute
 - 2 Wing Screw 1/4-20 x 1/2
 - 1 Wrench Box 8mm/10mm
 - 1 Wrench Hex-“L” 3mm
2. Slide the tab on the bottom side of the dust chute into the slot just below the chute on the left side of the base. Fasten the dust chute on with the 2 wing screws through the slots on both sides of the dust chute.
3. The 3mm hex-L wrench and 8mm open end wrench (supplied with the jointer) used for blade adjustments, can be conveniently stored in the dust chute as shown.

NOTE: If a dust collection system is not in use, simply loosen the two wing screws, lift the bottom of the chute up, out and then slide the dust chute up and retighten the wing screws.

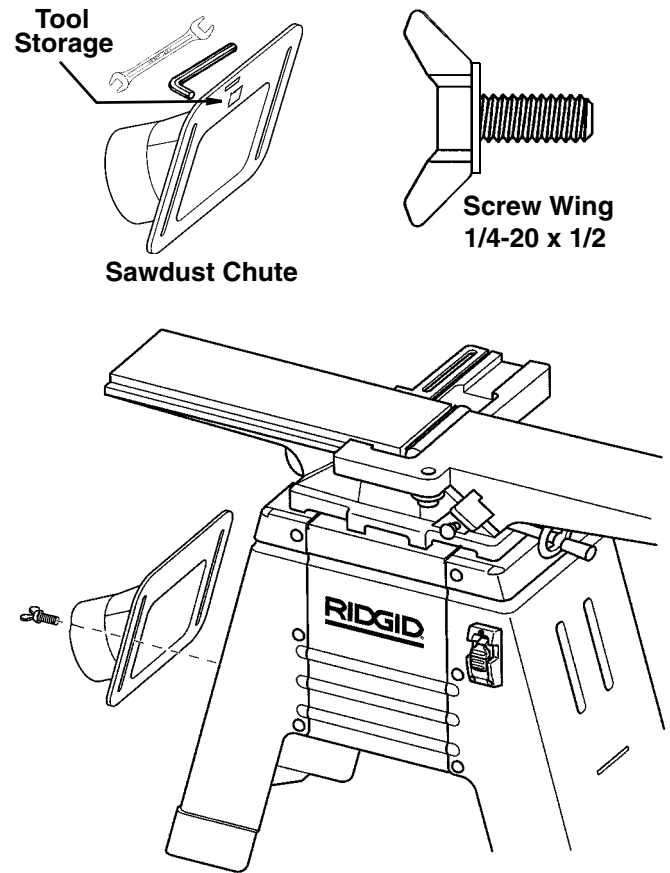

Adjusting Table Extension

The table extension is adjusted at the factory and should not require any additional adjustments. In the event that it shifted during shipping, align it to the outfeed table as follows.

1. Loosen the 2 hex head screws that attach the extension to the outfeed table.
2. Using a straight edge, align the extension to be flush with the outfeed table.
3. Tighten the two screws and recheck the alignment.

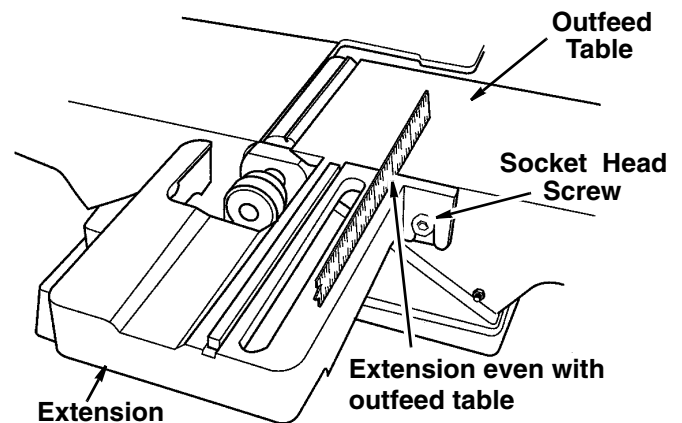

Assembly (continued)

Assemble Fence To Bed

1. From the hardware pack find the following:
 - 1 Washer 1/2"
 - 1 T-Nut
- From among the loose parts find the following
- 1 Fence Assembly
 - 1 Fence Lock Knob
 - 1 Fence Tilt Knob

2. Position fence onto fence support as shown making sure the keyway in fence assembly lines up with the key on the fence mount.
3. Once fence is in place, slide the fence lock knob through the 1/2" washer and then through the fence assembly and fence mount. Thread T-nut onto the end of the lock knob. Make sure the tabs on the nut sit in the slot on the fence mount.
4. Slide the fence back and fourth to make sure it moves freely. Then lock in place.
5. Thread the fence tilt knob into the fence.

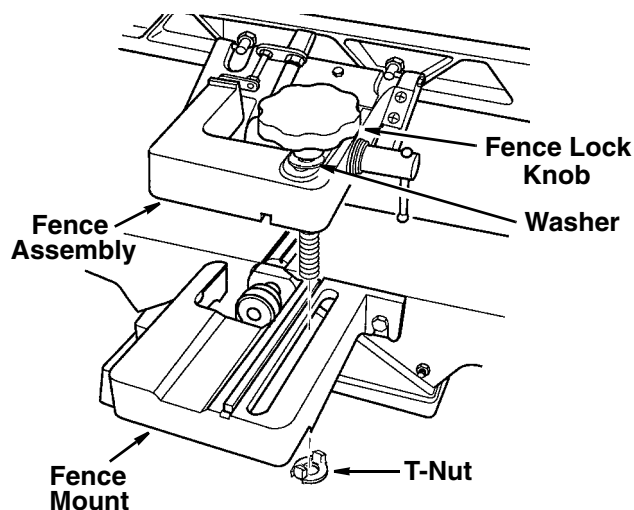
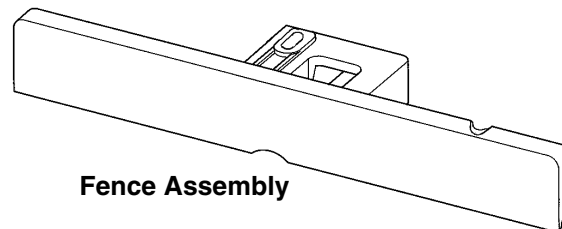
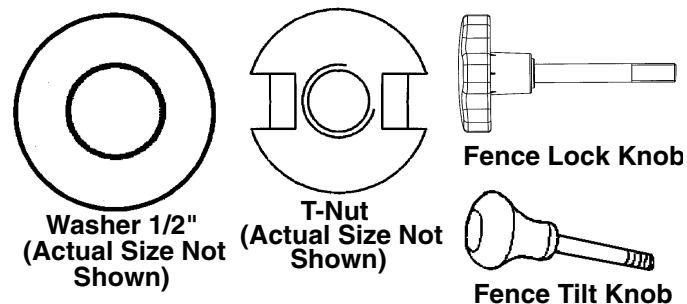

Install Cutter Head Guard

1. From among the loose parts find the cutter head guard. Remove the pan head screw from the bottom of the guard post.
2. Turn the spring-loaded knob 1 turn counterclockwise, looking down through the hole in the infeed table.
3. Line the slot in the guard post with the pin in the knob. Slide the post through table and over pin in the knob.
4. Reinstall the pan head screw in the bottom of the guard post.

NOTE: The two ribs on top of the fence indicate where the cutter head opening is located in the table.

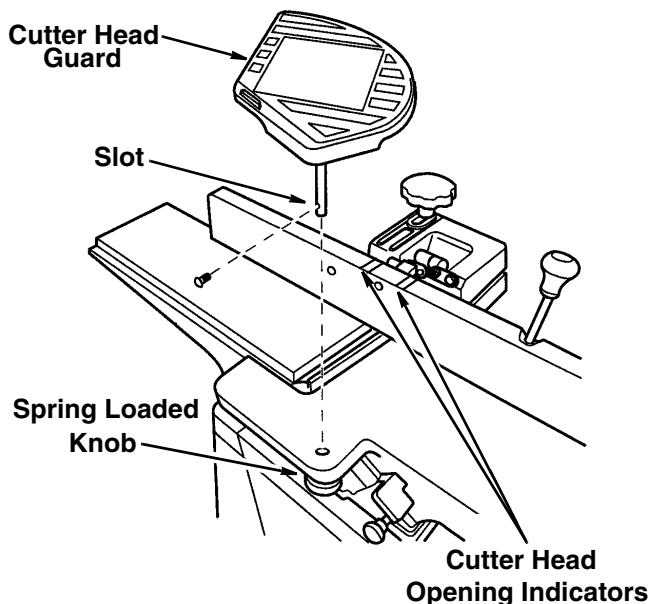

Cutter Head Guard Functional Check

⚠ WARNING: Cutter guard helps provide protection over the cutterhead. It must always be in place and functioning properly to prevent serious personal injury.

With the power off and the switch key removed, check the guard to make sure it is functioning properly.

- Position the fence to the rear of the bed for maximum width of cut. Do not position fence beyond rear edge of cutter knives.
- Pass a 1/4 inch thick piece of wood over the cutterhead between the guard and the fence.

The guard must return automatically to a “rest position” against the fence when free of the wood.

If guard does not return automatically, adjust the guard spring, as described in the next section.

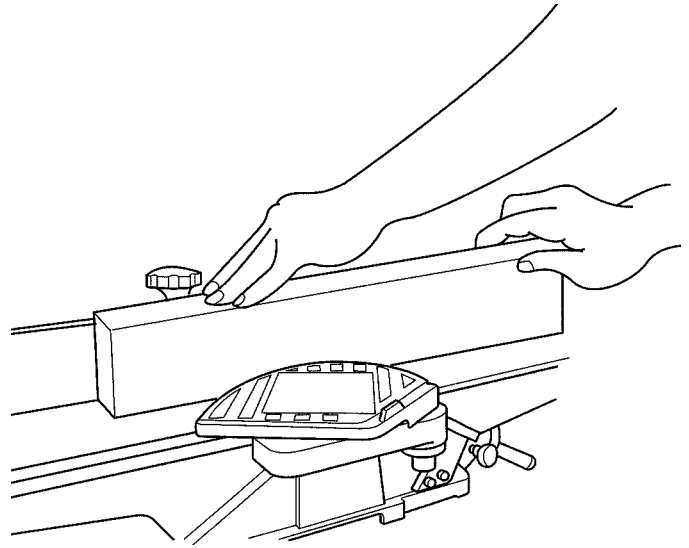

Adjusting Guard Spring

1. Remove the pan head screw from bottom of the guard post.
2. Remove tension on guard by turning tension knob clockwise. Pull up on guard to remove.
3. Add tension to the cutter head guard in 1/2 turn increments by turning the tension knob and reinserting the guard post.
4. Repeat Cutter Head Guard Functional check as previously described.

NOTE: Do not overtighten the spring. Overtightening may cause premature spring or guard breakage. If the guard or spring breaks or malfunctions, do not use the tool. Replace the defective parts before the tool is put back in service.

When the adjustment is complete, reinstall the pan head screw in the bottom of the guard post.

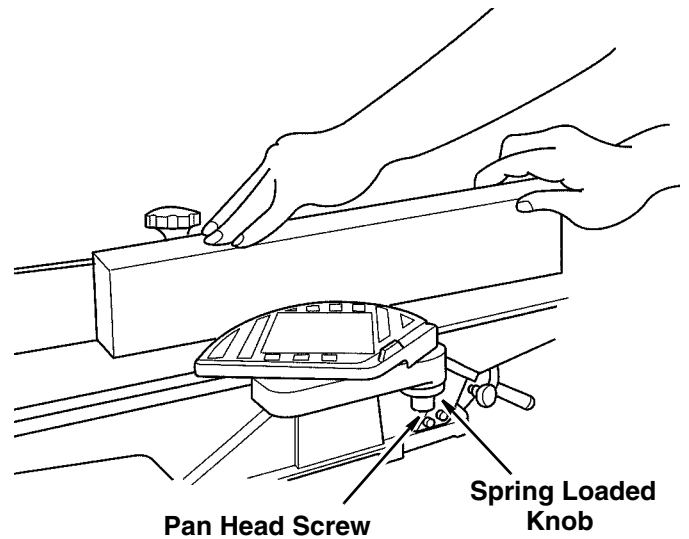

Adjusting the Leveling Feet

Move the jointer/planer to the location where it will reside during use.

Level the cabinet, loosen the nut and adjust leveling feet up or down as needed. Adjust all four leveling feet if necessary and then tighten the nut.

NOTE: These levelers are not intended for height adjustment, only leveling adjustment.

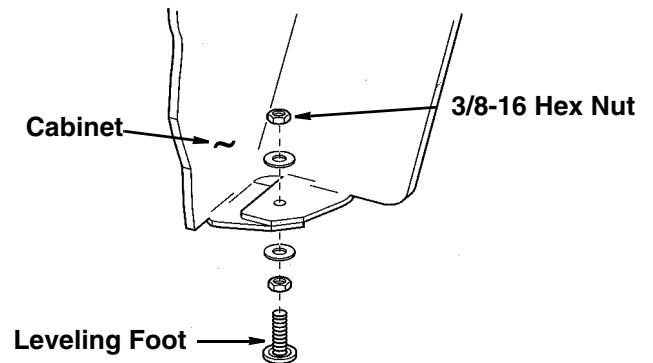

Getting to Know Your Jointer/Planer

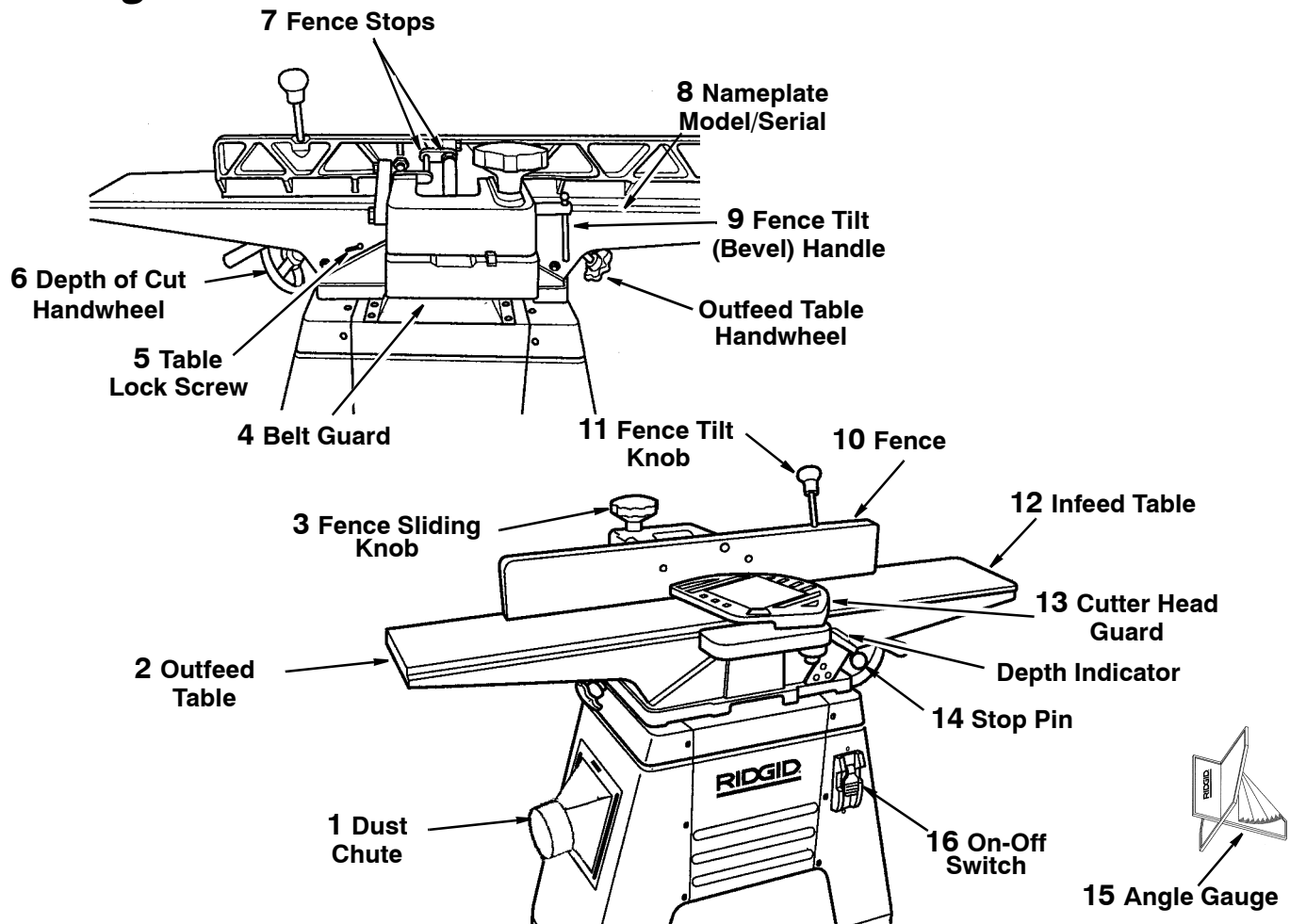

⚠ WARNING: For your own safety turn switch "OFF" and remove plug from power source outlet before making any adjustments.

1. Dust Chute with Tool Storage

Allows 4" diameter dust collection hose. Easily slides up and out of the way when a vacuum is not connected. Also tool storage for blade adjustment wrenches.

2. Outfeed Table

The section of a jointer bed which supports the workpiece after it passes over the cutter.

3. Fence Sliding Knob

Allows fence to move across table front to back. This is done to achieve full width of cut or to use a different (sharper) part of blade.

4. Belt Guard

Protects user from incidental access to the motor belt and pulley.

5. Table Lock Screw - When desired, use these screws to lock infeed or outfeed table at a desired height.

6. Depth of Cut Handwheel

By turning the handwheel you can control how much wood will be removed from the workpiece on each cut.

7. Fence Stops

When adjusted properly, these stops provide a method for quickly moving the fence to a 90°, 45° or 135° position from the table.

8. Nameplate Model/Serial

9. Fence Tilt (Bevel) Knob

Locks fence in various bevel positions.

10. Fence - Guides workpiece over cutter head.

11. Fence Tilt Knob - Used to adjust fence angle position.

12. Infeed Table

The section of the jointer bed upon which the workpiece is placed before being pushed into the cutter. Its height is adjustable which allows the operator to select the depth of cut.

13. Cutter Head Guard

Helps protect the operator from the sharp knives on the cutterhead. It is spring loaded so it automatically keeps the cutterhead covered before, during, and after a cutting operation. It must always be used.

14. Stop Pin

For rabbeting operations greater than 1/8" deep, pin can be pulled out to lower infeed table in 1/8" increments.

15. Angle Gauge

Used to set the fence at the proper angle.

⚠ WARNING: Before turning switch "ON", make sure the blade guard is correctly installed and operating properly to prevent serious personal injury.

16. On-Off Switch

Turns the tool on and off. The "yellow button" is a key. When it is inserted in the switch lever, the power may be turned ON and OFF. When it is removed, the power cannot be turned ON. This feature is intended to help prevent unauthorized and possible hazardous use by children and others.

The on-off switch is shaped to make turning it ON accidentally less likely.

In an emergency, it can be turned OFF by striking it with the palm of the hand.

- Insert key into switch.
- To turn the tool "On", insert finger under the switch lever and pull end of lever out.
- To turn the tool "Off", push the lever in. Never leave the tool unattended until it has come to a complete stop.
- To lock the switch in the "Off" position, hold the switch in with one hand and remove the key with the other hand as shown.

⚠ WARNING: To prevent unauthorized use always lock the switch "OFF" when jointer/planer is not in use. Remove key and keep it in a safe place to prevent serious personal injury. In the event of a power failure, turn switch off. Lock it and remove the key. This will prevent the jointer/planer from starting up again when the power comes back on.

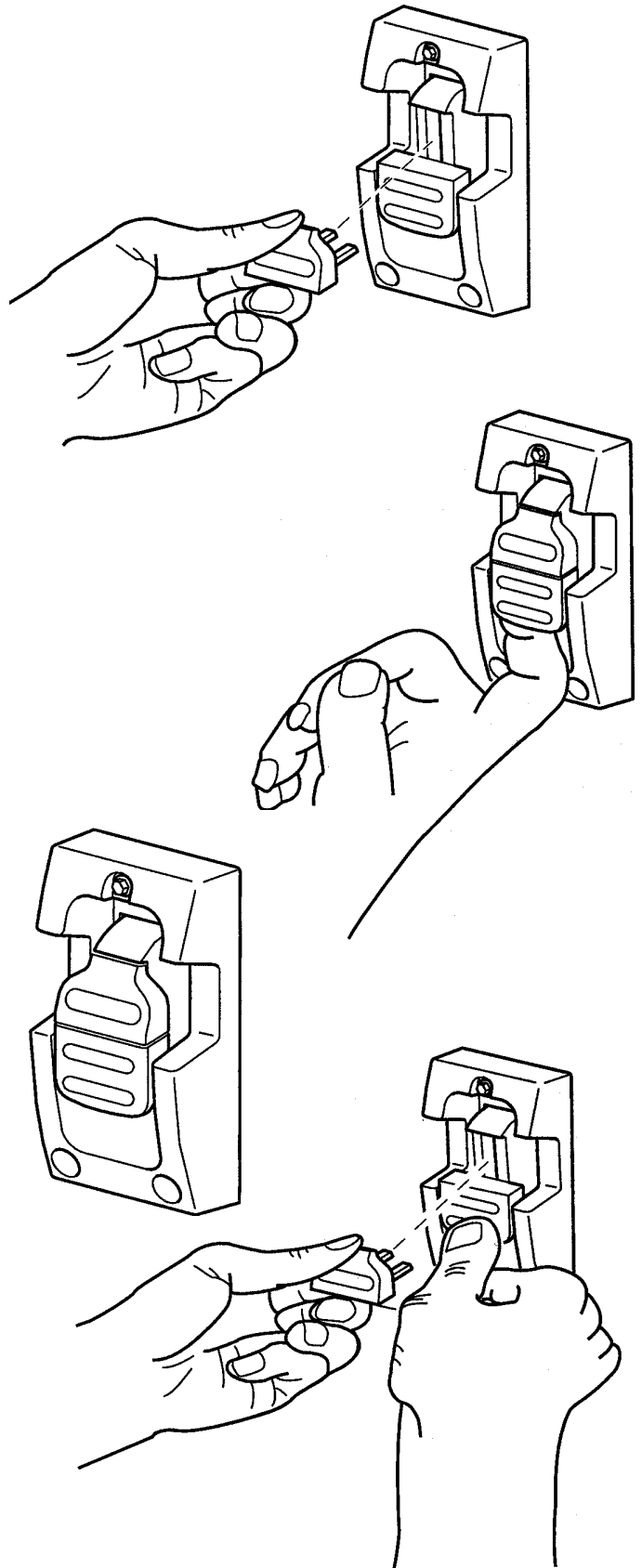

Alignments

Cutter Knife Alignment/Adjustments

⚠ WARNING: The cutter knives are extremely sharp. Do not let your hand or fingers touch the cutter knives to prevent serious personal injury.

Tools Needed

8mm open end wrench and 3mm Allen wrench (supplied).
Metal straightedge
• Unplug jointer/planer.

⚠ WARNING: To reduce the risk of injury from accidental start, make sure switch is "OFF" and plug is not connected to power source outlet.

Checking Alignment

Note: The blades are adjusted at the factory, and should not require adjustment.

1. Lower infeed table by turning the depth of the cut handwheel clockwise.
2. Position the fence to the rear of the jointer, approximately 1/4" beyond the end of the cutter knives. Lock the fence in this position.
3. Remove cutter head guard.
4. Place a straightedge on the outfeed table, extending over the cutter head as shown.
5. Adjust the outfeed table so that the straightedge just touches one of the knives as the cutter head is turned. Check one side of the knife then move the straightedge and check the other side of the knife. If the knife lifts the straightedge or does not touch it, readjust the knife as necessary (see procedure below). Check all three blades this same way.

Blade Adjustment

1. Loosen knife lock screws using the 8mm wrench, turning the wrench toward the fence. Remove all the parts and clean thoroughly with a gum and paste remover. Reinstall parts as shown, making sure the blade extends 1/16" past the cutter head as shown.
2. Place a straightedge as indicated in step 4 above. Position the straightedge over the end of one of the blades closest to the fence.
3. Rotate the cutter head so the knife that is being adjusted is at the highest point.
4. Adjust the jackscrew nearest to the straightedge so that the knife just touches the straightedge as the cutter head is rotated and there is no gap between the outfeed table and the straightedge.
5. Move the straightedge to the other end of the cutter head and repeat step 4 with the second jackscrew.
6. Tighten the four knife lock screws.
7. Repeat steps 1 through 6 for the other two knives.

Important: Turn the cutter head two full revolutions to make sure the cutter head turns freely and the blades clear the jointer bed.

8. Quickly recheck all three knives with the straightedge to ensure all knives are even and square.

⚠ WARNING: Read, understand and perform entire Alignment section before using the jointer/planer. Failure to heed this warning could result in serious

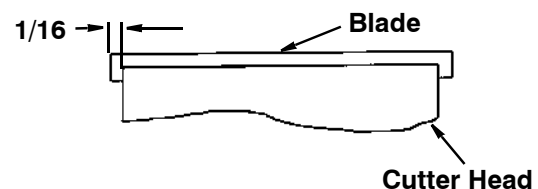
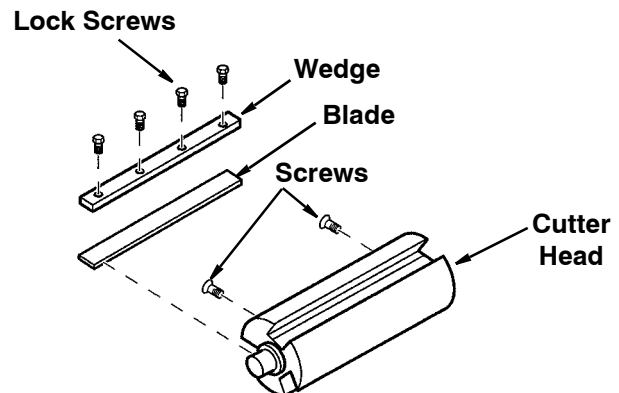
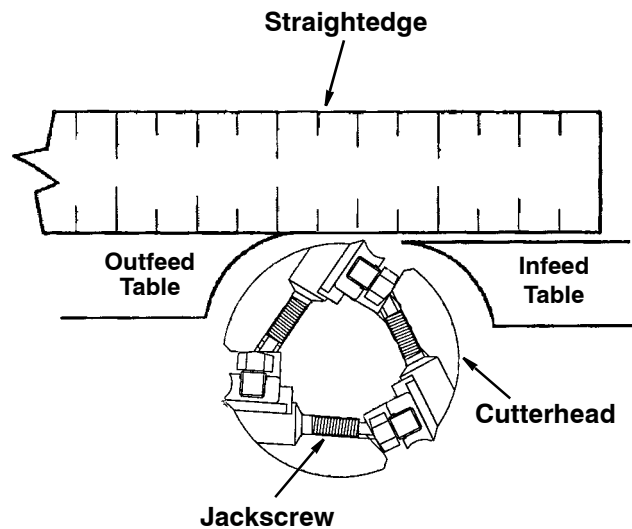

Cutter Knife Sharpening

The knives can be honed individually with an ordinary oilstone.

Make sure your oilstone is not worn in the center. It must be flat.

Be sure to remove the burr on the flat side.

⚠ WARNING: The cutter knives are extremely sharp. Do not let your hand or fingers touch the cutter knives.

If the knives are nicked they must be replaced or reground. They can be reground several times until they become 9/16" wide. **Never install unbalanced knives or reground knives less than 9/16" wide.**

Have your knives reground by someone who is competent. Look under "Sharpening Services" in the "Yellow Pages" of your telephone directory.

NOTE: The knives may have a second, very small ground surface very close to the sharpened edge of the blade. Hone only the edge of the blade which will be doing the cutting.

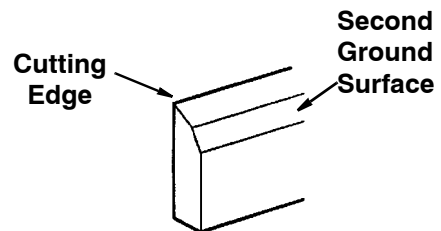
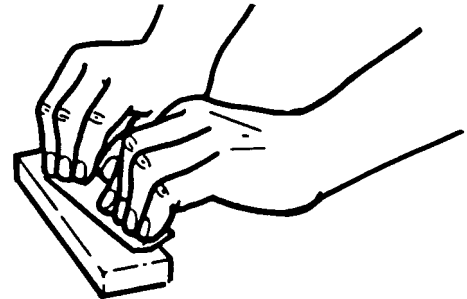
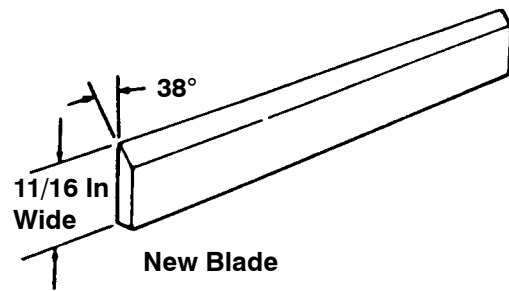

Alignments (continued)

Outfeed Table Adjustment

To check this alignment proceed as follows:

⚠ WARNING: To reduce the risk of injury from accidental start, make sure switch is "OFF" and plug is not connected to power source outlet.

NOTE: The outfeed table is adjusted at the factory and should not require adjustment.

1. Place a straightedge on the outfeed table, extending over the cutterhead as shown.
2. Rotate the cutterhead by hand. The blades should just touch the straightedge. If a knife is too low or too high at either end, readjust knife per "Cutter Knife Adjustment Replacement" procedure.
3. If outfeed table needs adjustment, loosen wing screw table locks. Raise or lower the outfeed table as required, by turning the outfeed table knob, until the outfeed table is exactly level with the knives of the cutterhead at their highest point of revolution.
4. After the outfeed table has been set at the correct height, lock in place using wing screw table locks. It should not be changed except after sharpening knives.
5. If the outfeed table is too high, finished surface will be curved as shown.
6. When the outfeed table is too low, the work will be gouged at the end of the cut.
7. As a final check of the outfeed table adjustment, run a piece of wood slowly over the knives for 6 to 8 inches; it should rest firmly on both tables, as shown, with no open space under the finished cut.

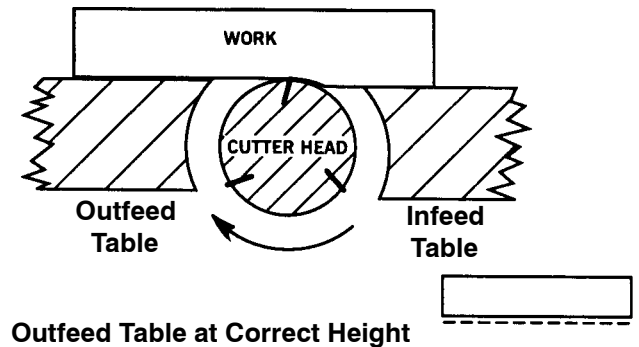
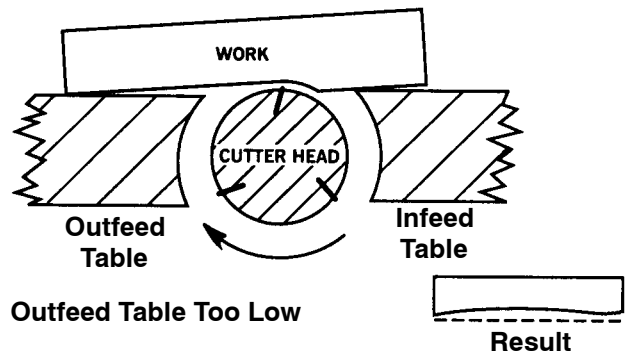
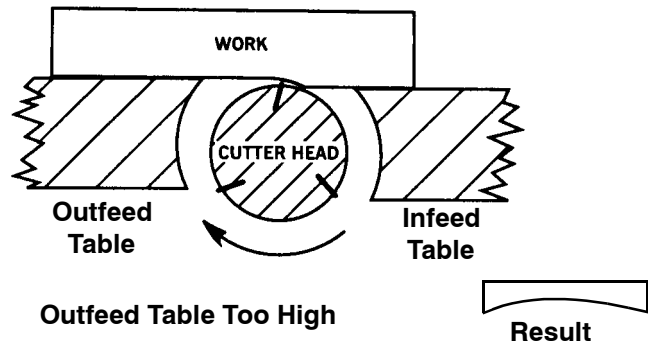
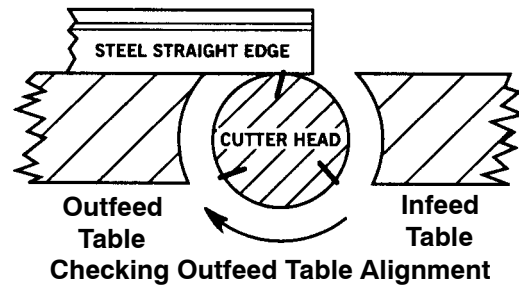

Adjusting Table Gibs

"Gibs" are provided to take up all play between the mating dovetail ways of the base and infeed and outfeed tables of your jointer. Proper gib adjustment is necessary for the correct functioning of the jointer. The gibs on your machine were adjusted at the factory and should require no further adjustment. However, to adjust the gibs proceed as follows:

1. Loosen each of the lock nuts. Make sure the table locks are also loose.
2. Finger tighten each set screw in turn, until the screw "bottoms out". Do not overtighten the screws.
3. Recheck table play. If table is still loose, repeat step 2. If table is snug, tighten the set screw lock nuts without allowing set screws to turn.
4. Check that the table raises and lowers freely with the elevation handwheel. If there is too much resistance, loosen the set screws and repeat adjustment.

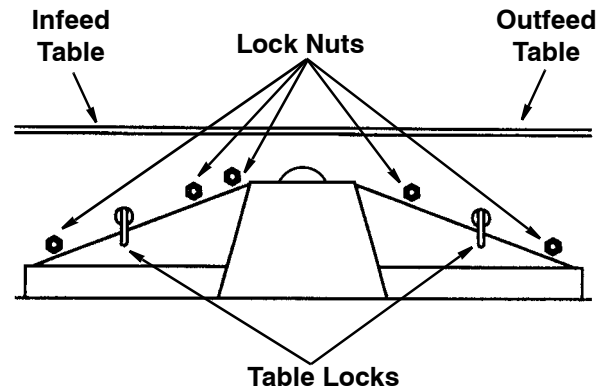

Adjustments located on rear side of tables

Angle Gauge Use

An angle gauge is included with the RIDGID jointer to set the fence at the proper angle. To assemble the gauge slide the one side over the other at right angles to each other. The angle gauge has several faces for some of the more common angle settings. These angles include 90°, 45°, 30° and 22.5°. There is also a 0°-45° protractor on one side to set your fence to an angle not provided. Simply set the gauge at the end of the fence on the outfeed table as shown and set the angle you need.

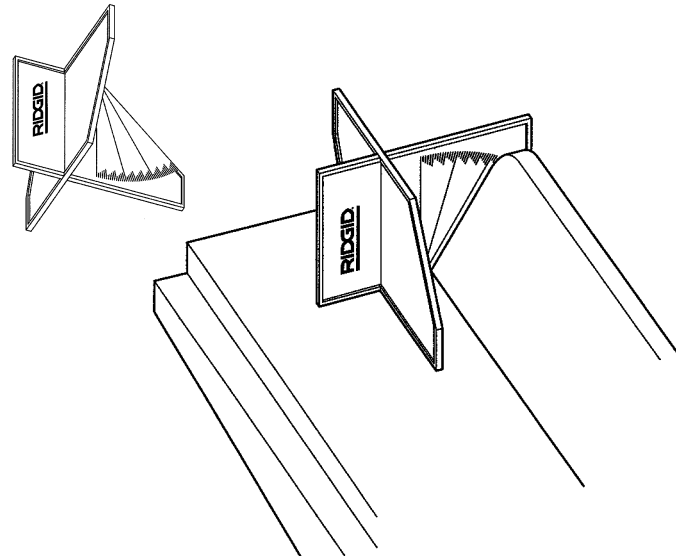

Fence Tilt Use and Bevel Stop Adjustment

This tool provides fence bevel stops at 90° (fence 90° from bed) and 45° forward and 135° backward.

To move the fence to the 45° forward position loosen the slide lock knob and the bevel lock handle. Pivot the top of the fence toward the front of the tool until it contacts the stop located on the back of the fence. Lock the slide lock knob and the bevel lock handle in place.

To bevel the fence back to the 135° position, loosen the slide lock and bevel lock as previously indicated, flip the 90° stop bar out of the way and bevel the fence back until it contacts the stop. Slide the fence back so that there is enough of the cutterhead is accessible to make the cut needed. Lock the slide lock knob and the bevel lock handle in place.

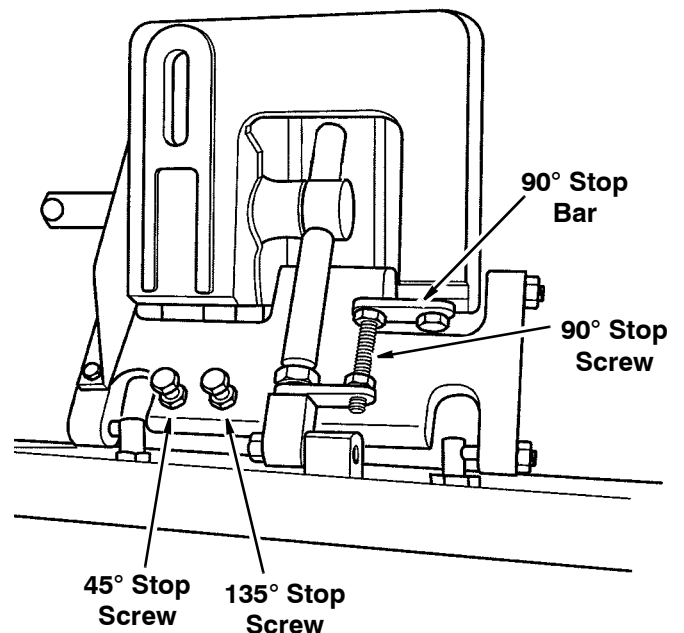

Alignments (continued)

To set the fence to 90° simply pivot the fence slightly forward of 90°, flip the 90° stop bar into place and pivot the fence back until it contacts the 90° stop and lock into place. The fence may need to be repositioned, using the slide lock knob, over the cutterhead to provide adequate cutting width.

The bevel stops are set at the factory, but may have fallen out of alignment while in transit. To check for squareness, place the included angle gauge on the outfeed table and check fence while locked in the 90° position.

To ensure accuracy and repeatability of the stops, the bottom of the outfeed side of the fence should rest firmly against the outfeed table and against the head of the stop screw. Make sure that the infeed table does not interfere with the accuracy of measurement. The infeed table should be lowered to a depth of at least 1/16". Using the stops, check the fence for accuracy. If the fence is not square to the outfeed table, at 90°, 45° or 135° perform the following procedure:

⚠ WARNING: To reduce the risk of injury from accidental start, make sure switch is "OFF" and plug is not connected to power source outlet.

90° Bevel Stop Adjustment

1. Loosen bevel lock handle.
2. Make sure fence is tight against the stop and check the angle using the included angle gauge.
3. Loosen the jam nut on the 90° stop screw.
4. Using the angle gauge, square the fence to the outfeed table and tighten the bevel lock handle.
5. Turn the stop screw so it touches the stop. Tighten the jam nut.
6. Loosen the bevel lock handle.
7. Move the fence to any angle and then return it to the index. Check for accuracy with angle adjustment gauge.

45° Bevel stop adjustment.

1. Loosen bevel lock handle.
2. Pivot the fence to the 45° stop and check with the angle gauge.

Safety Instructions for Basic Jointer/Planer Operation

Before Each Use

Inspect your jointer/planer.

⚠ WARNING: The 2-1/2 inch jointer/planer pulley and the 3-1/2 inch motor pulley furnished will run the cutter head at about 5000 RPM when used with a 3450 RPM motor. Use of different types of pulleys or motors will change this speed and could cause jamming, binding, kickback, thrown blades or other dangers. To prevent serious personal injury do not change original motor or pulleys.

- To reduce the risk of injury from accidental starting, always turn switch off, remove switch key and unplug

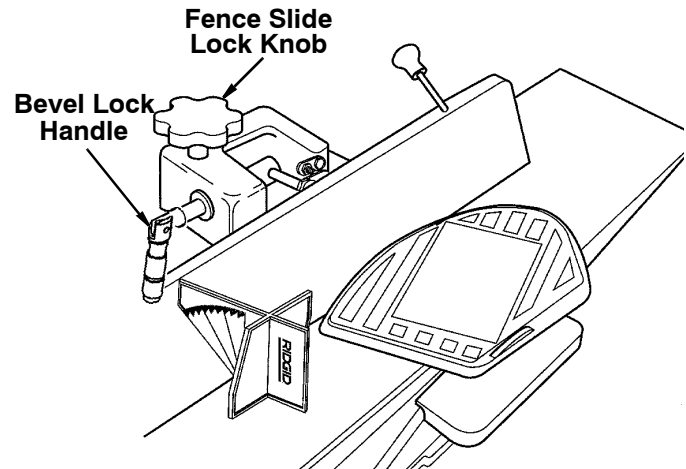

3. If any adjustment is necessary loosen the jam nut on the 45° stop screw.
4. Set the fence to 45° using the angle gauge and lock the bevel lock handle.
5. Turn the stop screw so it touches the stop. Tighten the jam nut.
6. Loosen the bevel lock handle and move the fence to any angle and back to 45°. Check for accuracy with the angle gauge.

135° Bevel stop adjustment

1. Loosen bevel lock handle.
2. Flip the 90° stop bar out of the way and move the fence until it contacts the 135° stop. Check with the angle gauge.
3. If any adjustment is necessary loosen the jam nut on the 135° stop screw.
4. Using the angle gauge, set the fence at 135° to the outfeed table and tighten the bevel lock handle.
5. Turn the stop screw so it touches the stop. Tighten the jam nut.
6. Loosen the bevel lock handle and move the fence to any angle and back to 135°. Check for accuracy with the angle gauge.

jointer/planer before installing or removing any blade, accessory or attachment or making any adjustments.

- If any part is missing, bent or broken in any way, or any electrical part does not work properly, turn the jointer/planer off and unplug the jointer/planer.
- Replace damaged or missing parts before using the jointer/planer again.
- Make sure the cutter head turns in the right direction. The top should move toward the infeed table. Call an Authorized Service Center for help if the cutter head turns the wrong way.
- Keep Jointer/Planer interior, free of wood chips and

dust buildup around motor and switch box.

- Keep blades sharp. Dull or nicked blades tend to “pound” and chew at the wood, causing kickbacks.
- Make sure the cutter guard works properly. With the switch off and key removed, pull the cutter guard open and let go. If the guard doesn’t smoothly swing closed, contact an Authorized Service Center.
- Don’t force the tool. It will do the job better and safer at the rate for which it was designed.

Push blocks and push sticks

Two plastic push blocks are supplied with your jointer/planer. Use them when practical. The rubber sole of the push blocks give better traction with the wood than your hands do. If they become slippery, they can be cleaned with rubbing alcohol, paint thinner or sandpaper.

▲ WARNING: Use rubbing alcohol or paint thinner only as described on their containers. Use only in well ventilated areas away from open flames, sparks or heat sources to prevent serious personal injury.

Feeding the Workpiece (All Operations)

▲ WARNING: Plan your work carefully. Use push-blocks for all jointing and planing operations for which such blocks are appropriate to prevent serious personal injury.

- Support long workpieces at both infeed and outfeed, as shown on page 30.
- Feed with grain whenever possible. When necessary to feed against grain, take very light cuts and feed slowly to minimize workpiece splintering, breakage or dangerous kickback.
- Keep steady pressure down on table and back against fence.
- As leading edge of board passes by cutterhead, slightly shift pressure to above cutterhead and outfeed

Push blocks can’t always be used. With larger workpieces, you may have better control of the workpiece using your hands. Always make a test pass first to determine which method gives you better control.

Before you make any cut, plan your hand positions. If a kickback should occur, plan so that your hands will not fall or be forced into the cutters.

Three Inch Rule (3")

Generally, if your hands are closer than three inches to the blade as you feed the wood, use push blocks. This gives extra protection to your hands by placing the push blocks between your hands and the cutters.

Always Use Push Blocks When Planing, Beveling Or Chamfering

When **jointing**, test for workpiece stability before actually jointing, and use push blocks when you can without sacrificing control.

table, away from infeed table. Keep pressure at outfeed table and near cutterhead for remainder of cut.

- Use hand-over-hand motion, releasing forward hand and moving it to rear, to continue feeding workpiece.
- Feed the board at a continuous rate until the cut is made along the entire length of the board. Any hesitation or stopping could cause a “step” on the edge of the board, resulting in an uneven edge as the cut is completed.
- If it is difficult to maintain steady rate, table or fence may need waxing (see Maintenance Section of manual.)

To Reduce the Risk of Injury From Jams, Slips Or Thrown Pieces (Kickbacks Or Throwbacks)

- Use this jointer/planer to cut only wood.
- Plan your hand placement so your fingers will not be anywhere a sudden slip could cause them to slide or fall into the cutter head. When using only one hold-down/push-block to feed the wood, do not put your other hand on the jointer/planer, workpiece, or hold-down/push-block.
- Make sure the clamps and locks are tight and there is not excessive play in any parts.
- To reduce the risk of injury from thrown pieces, make sure the blades are properly installed and the cutter blade wedge screws are tight.
- Adjust the depth of cut to between 1/32 and 1/16 of an inch for best results in most operations. A deep cut makes feeding the wood harder and can cause the wood to kickback. To be sure you will make a depth of cut you planned, always lower the infeed table slightly farther than you wanted. Then, raise the table to the desired depth.
- Use The Right Tool. Don’t force tool or attachment to do a job it was not designed for.

Inspect your work area.

- Keep work area clean.
- Cluttered areas and benches invite accidents. Floor must not be slippery from wax or sawdust.
- To reduce the risk of burns or other fire damage, never use the jointer/planer near flammable liquids, vapors or gases.
- Before using the jointer/planer, clear the table of all objects not needed to feed the workpiece.
- To reduce the risk of injury, don’t do layout, assembly, or setup work on the jointer/planer.
- Maintain tools with care. Keep tools sharp and clean for best and safest performance. Follow instructions for lubricating and changing accessories.

Plan your work

- Before trying a new or little used operation, carefully plan your hand placement. Make sure you have proper hold-down/push-blocks, jigs, fixtures, stops, etc. ready to use.
- To reduce the risk of injury from unsafe accessories, use only recommended accessories.

Safety Instructions for Basic Jointer/Planer Operation (continued)

Plan Ahead to Protect Your Eyes, Hands, Face and Ears

Dress for safety

- Plan ahead to protect your eyes, hands, face, ears.
- Do not wear loose clothing, gloves, neckties or jewelry (rings, wrist watches). They can get caught and draw you into moving parts.
- Wear nonslip footwear.
- Tie back long hair.
- Roll long sleeves above the elbow.
- Noise levels vary widely. To reduce the risk of possible hearing damage, wear ear plugs or muffs when using jointer/planer for hours at a time.
- Any power tool can throw foreign objects into the eyes. This can result in permanent eye damage. Always wear safety goggles, not glasses, complying with ANSI Z87.1 (or in Canada CSA Z94.3-99) shown on package. Everyday eyeglasses have only impact resistant lenses. They are not safety glasses. Safety goggles are available at many local retail stores. Glasses or goggles not in compliance with ANSI or CSA could seriously hurt you when they break.
- For dusty operations, wear a dust mask along with safety goggles.

Inspect your workpiece.

- Make sure there are no nails or foreign objects in the part of the workpiece to be cut.

Plan your cut.

- Small or thin workpieces can kickback when they tip over on the tables or into the cutter head. To reduce the risk of head contact or workpiece kickback:
 - Never joint, plane or bevel workpieces shorter than 12 inches.

• When jointing:

- Never joint workpieces less than 3/4 inch wide or 1/4 inch thick.
- Always use the hold-down/push-blocks when jointing or beveling wood narrower than 3 inches.
- When rabbeting, always make cuts in 1/8" increments or less.

• When planing or beveling:

- Never plane wood thinner than 1/2 inch.
- Always use hold-down/push-blocks when planing.
- Never cut **Freehand**. Guide your workpiece solidly against the fence and table top.
- Make sure there's no debris between the workpiece and its supports.

• Use extra caution with large, very small or awkward workpieces.

• Use extra supports (tables, saw horses, blocks, etc.) if your workpiece is hard to hold down to the table. Never use another person as additional support or to help feed, support or pull the workpiece.

• Never cut more than one workpiece at a time.

• Never turn your jointer/planer "ON" before clearing everything except the workpiece and related support devices off the table.

• Don't overreach. Keep proper footing and balance at all times.

• Maintain tools with care. Keep tools sharp and clean for best and safest performance. Follow instructions for lubricating and changing accessories.

Reduce the Risk of Accidental Starting.

- Make sure switch is "OFF" before plugging jointer/planer into a power outlet.

Whenever Jointer/Planer Is Running

⚠ WARNING: Don't allow familiarity (gained from frequent use of your jointer/planer) cause a careless mistake. Always remember that a careless fraction of a second is enough to cause a severe injury.

Keep Children Away.

- Keep all visitors a safe distance from the jointer/planer.
- Make sure bystanders are clear of the jointer/planer and workpiece.
- Before actually cutting with the jointer/planer, let it run for a while. If it makes an unfamiliar noise or vibrates, stop immediately. Turn the jointer/planer off. Unplug the jointer/planer. Do not restart until finding and correcting the problem.

Don't Force Tool.

- Feed the workpiece into the jointer/planer only fast enough to let the tool cut without bogging down or binding.

Before freeing jammed material.

- Turn switch "OFF".
- Wait for all moving parts to stop.
- Unplug the jointer/planer.
- Check blades, cutter and fence for proper alignment before starting again.

Before Leaving the jointer/planer.

- Turn the jointer/planer off.
- Wait for jointer/planer to come to a complete stop.
- Unplug the jointer/planer.
- Make workshop child-proof. Lock the shop. Disconnect master switches. Remove the yellow switch key. Store it away from children and others not qualified to use the tool.

Basic Jointer/Planer Cutting Operations

Depth of Cut Handwheel Operation

Turning the handwheel clockwise will lower the infeed table. This will cause more wood to be removed from the workpiece during the cutting operation.

Turning the handwheel counterclockwise will raise the infeed table causing less wood to be removed from the workpiece.

The maximum amount of wood that can be removed during one cut is 1/8".

Stop Pin Operation

A stop pin is supplied to prevent planing or jointing more than 1/8" depth of cut. Planing and jointing operations greater than 1/8" per pass are not recommended. Only rabbeting operations should be performed at cutting depths greater than 1/8". Never cut a full 1/2" rabbet in one cut. Cut in 1/8" depth increments until your full depth is acquired.

Feeding the Workpiece

Hold the board firmly down on both tables and against the fence. Keep fingers close together. Feed the board at a continuous even rate of speed until the cut is made along the entire length of the board. Any hesitation or stopping could cause a "step" to be cut on the edge of the board which would cause the board to ride up on the outfeed table resulting in a "crooked" edge on the board.

As the **trailing** hand passes over the cutterhead, remove the **leading** hand. Continue feeding while placing the **leading** hand behind the **trailing** hand. Continue feeding in this manner "hand over hand", until the entire length of the board is cut. As soon as enough of the workpiece has been cut to do so, put **pressure over the cutterhead and outfeed table**.

Do not feed too fast. A slow steady rate of feed produces a smooth accurate cut. Feeding too fast causes a "rippled" cut, makes it difficult to guide the workpiece accurately, and could be dangerous.

NOTE: Wood chips may accumulate inside the jointer/planer. Periodically clean out the chips from the interior of the jointer/planer.

NOTE: Before cleaning wood chips.

- Turn switch "OFF".
- Wait for all moving parts to stop.
- Unplug the jointer/planer.

Feed **with the grain** whenever possible. If the nature of the workpiece is such that it must be fed **against the grain**, take very light cuts and feed slowly.

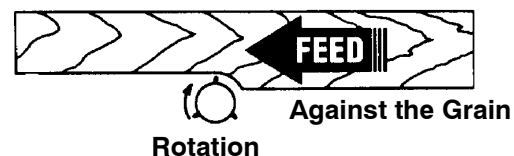
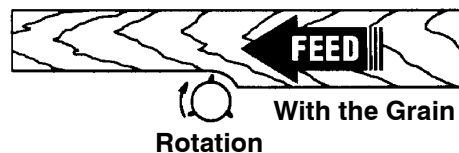
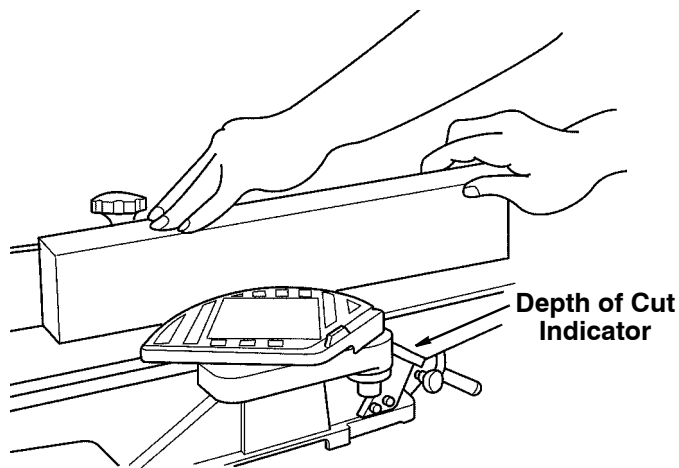

Basic Jointer/Planer Cutting Operations (continued)

Planing

⚠ WARNING: To avoid risk or injury from cutterhead contact, always use push blocks when planing.

- Follow all instructions above for “Feeding the Workpiece”.
- Keep fingers close together so they do not hang down toward the knives.

Planing is removing wood from the widest surface or face of a board so as to make it flat and smooth.

Planing on a jointer will not necessarily make the face that is planed square or parallel to any other surface. Planing on a jointer only smooths and flattens. If you are planing and jointing a board, the planing operation should be performed first. This allows the jointed edge to be cut square to the face which was previously planed flat and smooth.

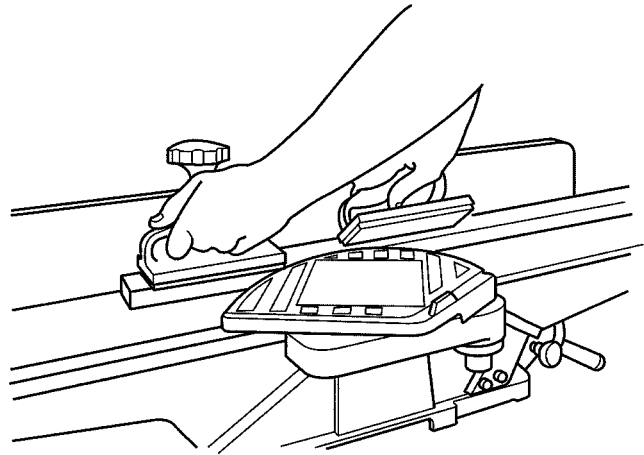

Jointing

Jointing is the removal of wood along the edge of a piece of wood so as to make that edge straight, smooth and square to the wood face which is against the fence.

To ensure a square cut, the workpiece face must be held flat against the fence throughout the entire cut.

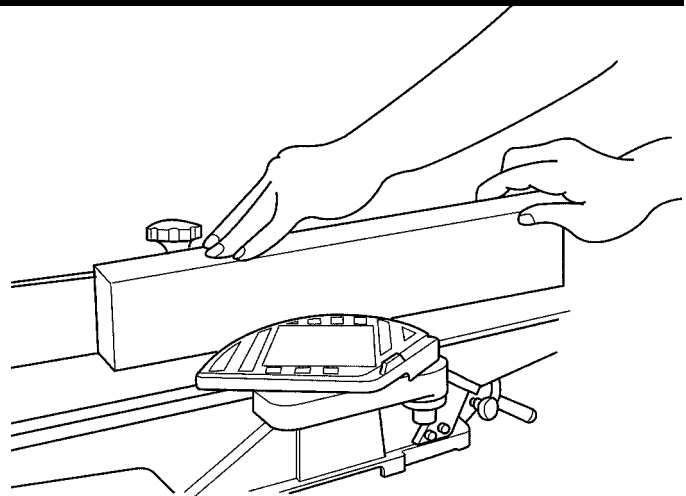

Jointing Without Push Blocks

Beveling/Chamfering

Adjust the fence to the desired angle. Lock fence in position using fence tilt knob and fence sliding knob.

⚠ WARNING: To avoid risk or injury from cutterhead contact, always use push blocks when beveling or chamfering.

- Adjust fence to desired angle. Lock fence lock knob and sliding guard knob.
- Make a test pass to assure you have control of the workpiece.

NOTE: Removing only the corner on the edge of a board is known as **chamfering** while **beveling** is removing the corner or the edge of the board down to the board's surface.

Normally a chamfer is made with one cut and only the corner of the wood is cut off. Therefore, a cut deeper than 1/16 of an inch may be made.

⚠ WARNING: Do not contact the cutting knives or the guard with the push-blocks. Failure to heed this warning could result in serious personal injury.

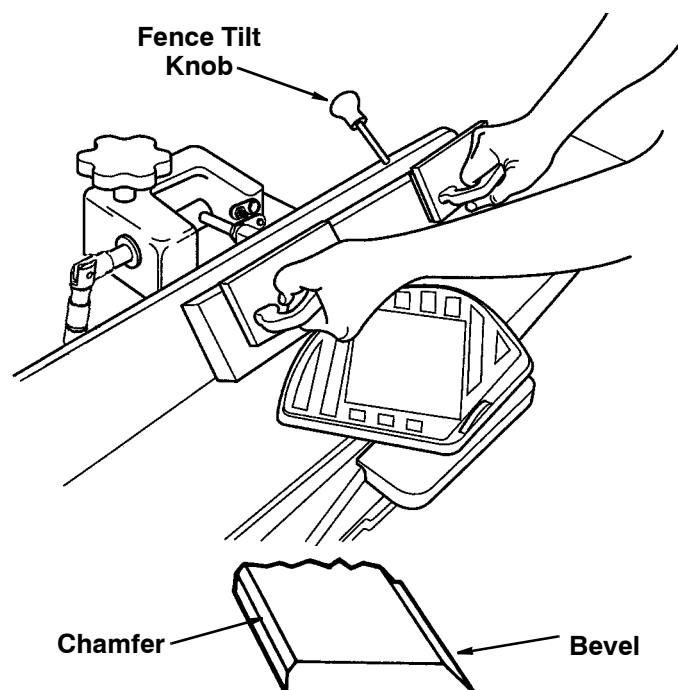

Rabbeting

Rabbeting is very similar to jointing except that only part of the edge is jointed. Do not remove the guard for rabbeting. To rabbet hold the workpiece firmly against the fence. Do not make cuts greater than 1/8". To make a deeper rabbet, make cuts in 1/8" deep increments. Because the workpiece is supported by the outfeed table during a rabbet cut, the infeed table must be lowered after each pass.

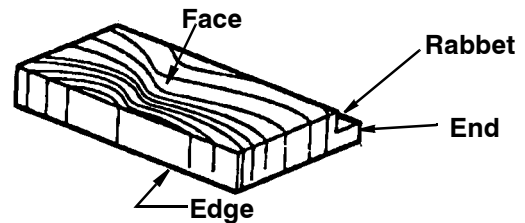

Stop Pin Operation

A stop pin (item #13 page 19) is supplied to prevent against planing or jointing more than 1/8" depth of cut. Planing and jointing operations greater than 1/8" per pass are not recommended. Rabbeting operations greater than 1/8" can be performed by pulling the stop pin out and lowering the infeed table in 1/8" increments. The pin automatically resets when you return to the 0" to 1/8" depth of cut range. Never cut a full 1/2" rabbet in one cut. Cut in 1/8" depth increments until your full depth is acquired.

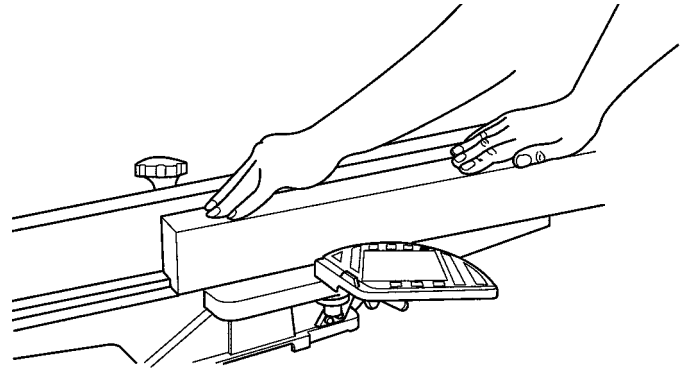

Support Long Workpieces

To reduce the risk of injury from slips or kickbacks, use extra supports (tables, saw horses, etc.) at both infeed and outfeed ends if your workpiece is hard to hold down to the table.

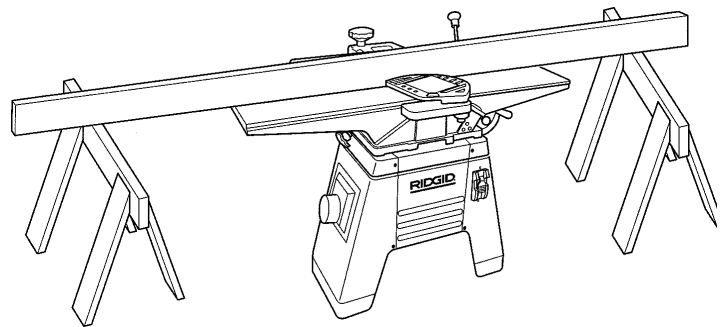

Using the Hold-Down/Push-Blocks

Always use the hold-down/push-blocks whenever possible when jointing or rabbeting wood.

Grasp the hold-down/push-blocks firmly with the fingers close together and wrapped around the handle. Position the hold-down/push-blocks flat, on top of workpiece and push the workpiece down against the table. This helps to provide a quality cut and minimize the chance of a kickback.

Hold-down pressure must also be sufficient to prevent hold-down/push-block from sliding or slipping on the top face of workpiece when advancing workpiece over cutterhead.

Use a hand-over-hand motion of the hold-down/push-blocks, being careful to maintain control over the workpiece at all times.

This means that once the workpiece has been fed past the cutterhead onto the outfeed table, one hold-down/push-block must always maintain contact with the workpiece on the outfeed table.

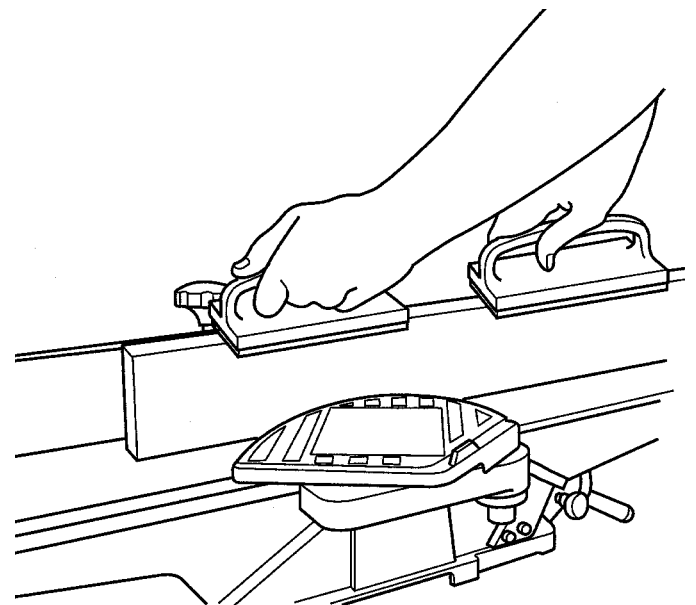

Basic Jointer/Planer Cutting Operations (continued)

⚠ WARNING: If the hold-down/push-blocks tend to slip while feeding, clean rubber surface immediately with sandpaper to prevent serious personal injury.

When planing wood between 1/2 inch and 3/4 of an inch thick and narrower than the hold-down/push-block, tilt the hold-down/push-block so that it clears the tip of the cutter guard while feeding.

Never plane wood that is thinner than 1/2 inch. It is apt to split or shatter and thus has a greater tendency to kick-back.

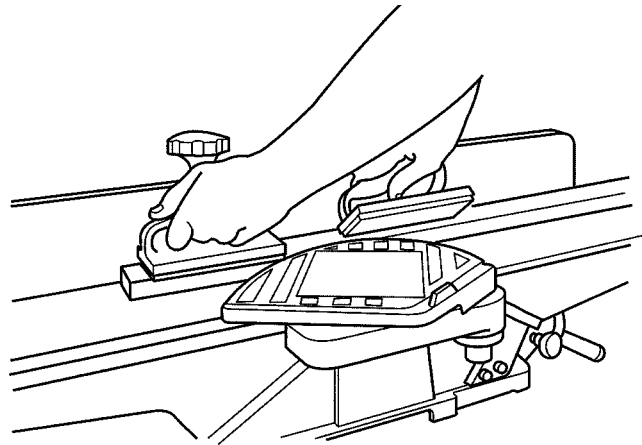

Sliding Fence Operation

⚠ WARNING: Moving parts can injure. Turn jointer/planer off and wait for all parts to stop, before adjusting fence.

When you are not cutting at full width of cut the fence can be moved across the jointer/planer to take full advantage of the "sharpness" of the blades.

When blades are new or freshly sharpened the fence should be positioned to the extreme rear of outfeed and infeed tables but not beyond the end of the blades.

Most of the cutting (usually jointing) will be done with the fence in this position. As the blades become dull, the fence can be moved toward the guard where the blades are sharper.

To move the fence, turn jointer/planer off, loosen Sliding Fence Knob and slide the fence to the desired position.

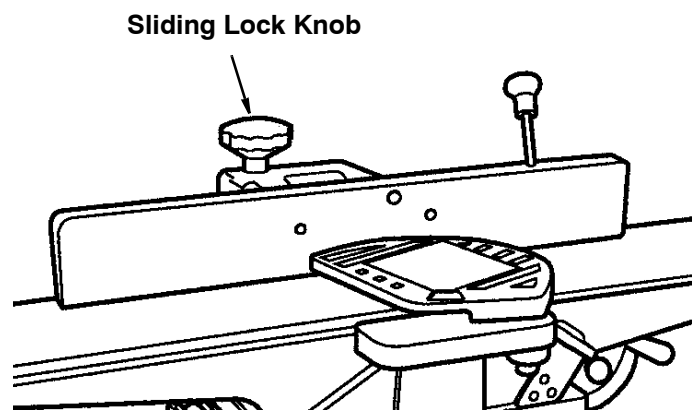

Maintenance and Lubrication

Maintenance

Do not allow pitch to accumulate on the tables, the fence, the cutter guard, the cutterhead or the knives. Clean them with an appropriate solvent.

Apply a thin coat of paste type wax to the tables and the fence so that the wood slides easily while feeding. This also deters rusting.

Do not allow chips to accumulate on the underside of the jointer/planer.

If power cord is worn, cut, or damaged in any way, have it replaced immediately.

Disassembly of the motor should only be done by an Authorized Service Center. Disregarding this may void your tools warranty.

NOTE: The speed of this motor cannot be regulated or changed.

Motors used on woodworking tools are particularly susceptible to the accumulation of sawdust and wood chips and should be blown out or "vacuumed" frequently to prevent interference with normal motor ventilation.

Lubrication

⚠ WARNING: Unplug the jointer/planer. Unit could start suddenly. You could be badly hurt.

The ball bearings in this machine are packed with grease at the factory. They required no further lubrication.

The following parts should be oiled occasionally with SAE No. 20 or No. 30 engine oil.

1. Dovetail spacer and dovetail slide.
2. Elevation screw (first clean if necessary).

Wiring Diagram

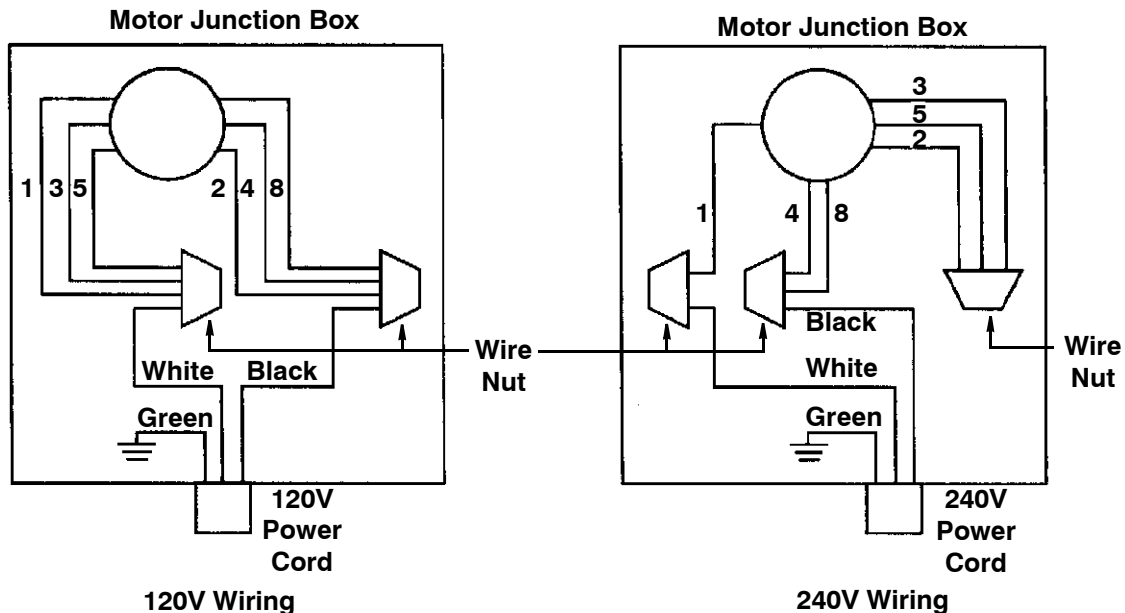

Troubleshooting Guide

⚠ WARNING: For your own safety, turn switch “OFF” and remove plug from power source outlet before troubleshooting your jointer/planer.

General

Trouble	Probable Cause	Remedy
Motor will not run	<ol style="list-style-type: none"> 1. Defective On-Off switch Defective capacitor Defective motor 2. Low line voltage 3. Belt tension too high 	<ol style="list-style-type: none"> 1. Consult an Authorized Service Center. Any attempt to repair this electrical device may create a hazard unless repair is done by a qualified service technician. Repair service is available at your nearest Authorized Service Center. 2. See “Troubleshooting (Motor)” section. 3. Adjust belt tension
Wood strikes outfeed table after passing over cutterhead	Outfeed table improperly adjusted above cutter blades	Readjust table, see “Outfeed Table Adjustment” section
Ripples on planed surface Kickbacks	<ol style="list-style-type: none"> 1. One blade set higher than other 2. Feeding wood too fast 3. Cutting blades are set too high above outfeed table, or they are not leveled with outfeed table 	<ol style="list-style-type: none"> 1. Readjust blades, see “Maintenance” section 2. Feed wood slower 3. Readjust blades, see “Maintenance” section
Planed surface not straight	Outfeed table out of adjustment	Readjust table, see “Outfeed Table Adjustment” section
Excessive gouging at end of cut	Outfeed table set too low	Readjust table, see “Outfeed Table Adjustment” section
45°, 90° and 135° cuts inaccurate	<ol style="list-style-type: none"> 1. Fence stops not adjusted properly 2. Fence bottom not even with outfeed table due to wood chips under fence 	<ol style="list-style-type: none"> 1. Readjust fence stops, see “Alignment” section 2. Clean wood chips from underside of fence
Infeed or outfeed table loose	1. Loose gib	1. Tighten gibs
Cutter guard does not function properly	1. Return spring broken, or spring needs adjustment	<ol style="list-style-type: none"> 1. Consult an Authorized Service Center immediately if broken. 2. Adjust spring.

Motor

NOTE: Motors used on wood working tools are particularly susceptible to the accumulation of sawdust and wood chips and should be blown out or “vacuumed” frequently to prevent interference with normal motor ventilation.

Trouble	Probable Cause	Remedy
Excessive noise	<ol style="list-style-type: none"> 1. Motor 2. Pulley set screw is loose. 	<ol style="list-style-type: none"> 1. Have motor checked by qualified service technician. Repair service is available at your nearest Authorized Service Center. 2. Tighten set screw.
Motor fails to develop full power. NOTE: Low voltage (Power output of motor decreases rapidly with decreases in voltage at motor terminals. For example, a reduction of 10% in voltage causes a reduction of 19% in maximum power output of which the motor is capable, and a reduction of 20% in voltage causes a reduction of 36% in maximum power output.)	<ol style="list-style-type: none"> 1. Circuit overloaded with lights, appliances and other motors. 2. Undersize wires or circuit too long. 3. General overloading of power company facilities. 	<ol style="list-style-type: none"> 1. Do not use other appliances or motors on same circuit when using the jointer. 2. Increase wire sizes, or reduce length of wiring. See “Motor Specifications and Electrical Requirements” section. 3. Request a voltage check from the power company.
Motor starts slowly or fails to come to full speed	<ol style="list-style-type: none"> 1. Windings burned out or open. 2. Drive belt tension too high. 3. Defective start capacitor 	<ol style="list-style-type: none"> 1. Have motor repaired or replaced 2. Adjust belt tension 3. Have start capacitor replaced
Motor overheats	<ol style="list-style-type: none"> 1. Motor overloaded 2. Improper cooling. (Air circulation restricted through motor due to sawdust accumulating inside of motor.) 	<ol style="list-style-type: none"> 1. Feed work slower into blade. 2. Clean out sawdust to provide normal air circulation through motor. See “Maintenance and Lubrication” section.
Motor stalls (resulting in blown fuses or tripped circuit breakers.)	<ol style="list-style-type: none"> 1. Voltage too low to permit motor to reach operating speed. 2. Fuses or circuit breakers do not have sufficient capacity. 3. Circuit overloaded with lights, appliances and other motors. 	<ol style="list-style-type: none"> 1. Request voltage check from the power company 2. Install proper size fuses or circuit breakers. See “Electrical Connection” section 3. Do not use other appliances or motors on same circuit when using the jointer.
Frequent opening of fuses or circuit breakers	<ol style="list-style-type: none"> 1. Motor overloaded 2. Fuses or circuit breakers do not have sufficient capacity. 3. Circuit overloaded with lights, appliances and other motors. 	<ol style="list-style-type: none"> 1. Feed work slower 2. Install proper size fuses or circuit breakers. See “Electrical Connection” section 3. Do not use other appliances or motors on same circuit when using the jointer.

Parts List for RIDGID 6-1/8" Jointer/Planer Model No. JP06101

RIDGID parts are available on-line at www.ridgidparts.com

Figure 1

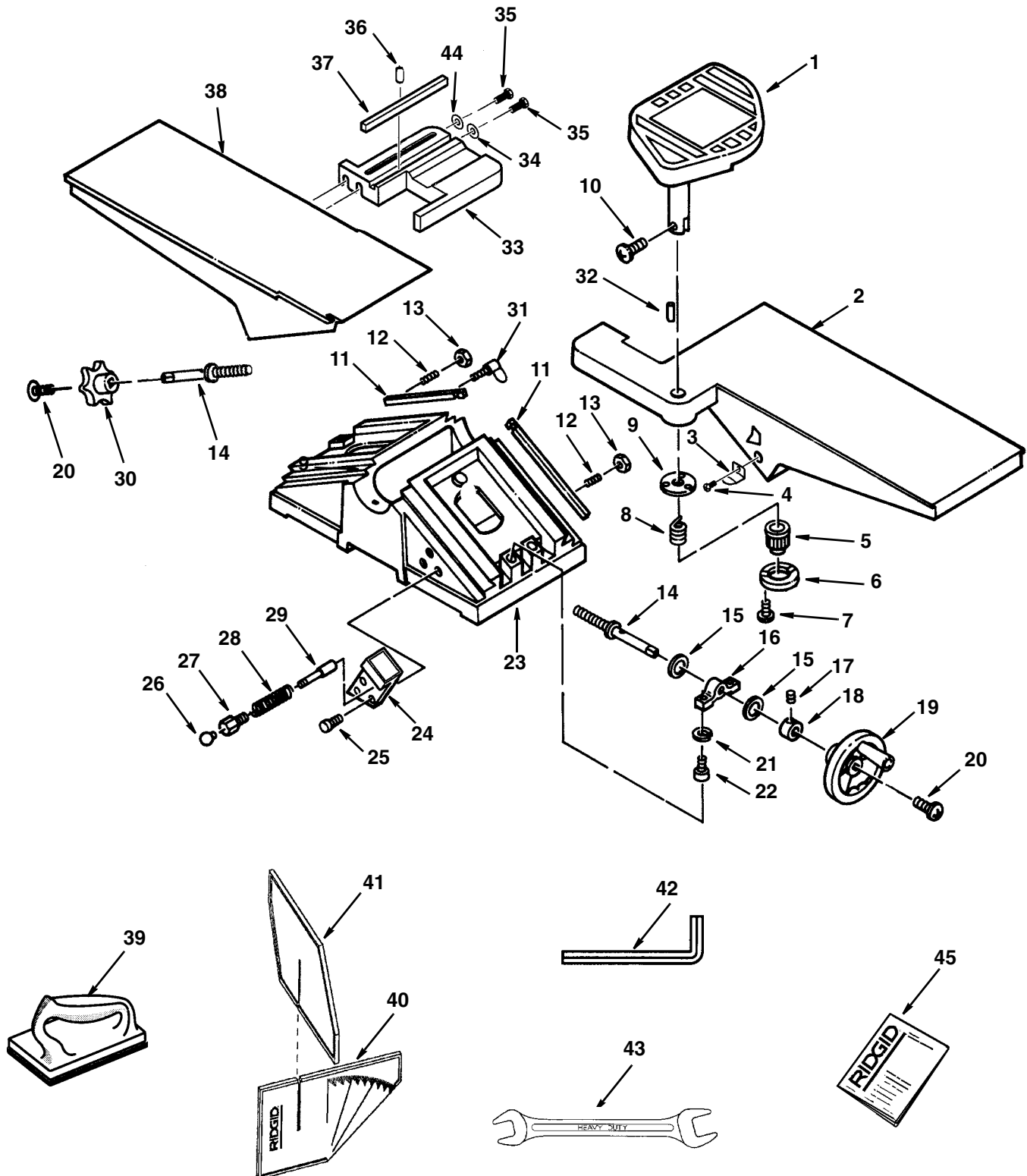

Parts List for RIDGID 6-1/8" Jointer/Planer Model No. JP06101

RIDGID parts are available on-line at www.ridgidparts.com

Figure 1

Always order by Part Number - Not by Key Number

Key No.	Part No.	Description
1	826655	Guard Cutter
2	824854-1	Table Infeed
3	828397	Pointer Indicator
4	822495	* Screw Pan Hd. 8-32 x 1/4
5	824867	Knob
6	824866	Retainer Knob
7	822495-1	* Screw Pan Hd 8/32 x 5/8
8	824868	Spring
9	824865	Retainer
10	816755-1	* Screw Pan Hd M5 x 0.8-10
11	824856	Gib
12	160033-4	* Screw Set 1/4-20 x 1
13	805478	* Nut Hex 1/4-20
14	824859	Screw Elevation
15	824860	Washer Brass
16	824858	Clamp
17	160033-1	* Screw Set 1/4-20 x 3/8
18	824861	Collar
19	826524	Handwheel
20	828711	Screw Pan Hd 1/4-20 x 5/8
21	818826-7	* Lockwasher 8mm
22	141594-13	* Screw Cap 5/16-18 x 1-1/4
23	824853-1	Base
24	828649	Block Asm Depth

Key No.	Part No.	Description
25	9421622	Screw Cap 5/16-18 x 3/4
26	826529	Knob Plunger
27	824873	Housing Plunger
28	824872	Spring
29	824874	Plunger
30	826523	Knob Outfeed
31	824857	Screw Wing 1/4-20 x 1
32	813249-132	Pin Spring 5 x 30
33	828531	Slide Fence
34	824863	Washer 3/8 x 20mm x 3mm
35	141594-44	* Screw Cap 3/8-16 x 1/2
36	813249-106	Pin Roll 4mm x 20mm
37	828523	Key
38	824855-1	Table Outfeed
39	AC8601	† Push Block
40	828402	Angle Gauge - Part A
41	828403	Angle Gauge - Part B
42	813317-6	* Wrench Hex "L" M3
43	821202	* Wrench Box M8/M10
44	820296-5	Washer Flat 10mm
45	SP6442	Operator's Manual

* Standard hardware item, may be purchased locally

† These replacement parts are available where you purchased your jointer.

Parts List for RIDGID 6-1/8" Jointer/Planer

Model No. JP06101

RIDGID parts are available on-line at www.ridgidparts.com

Figure 2

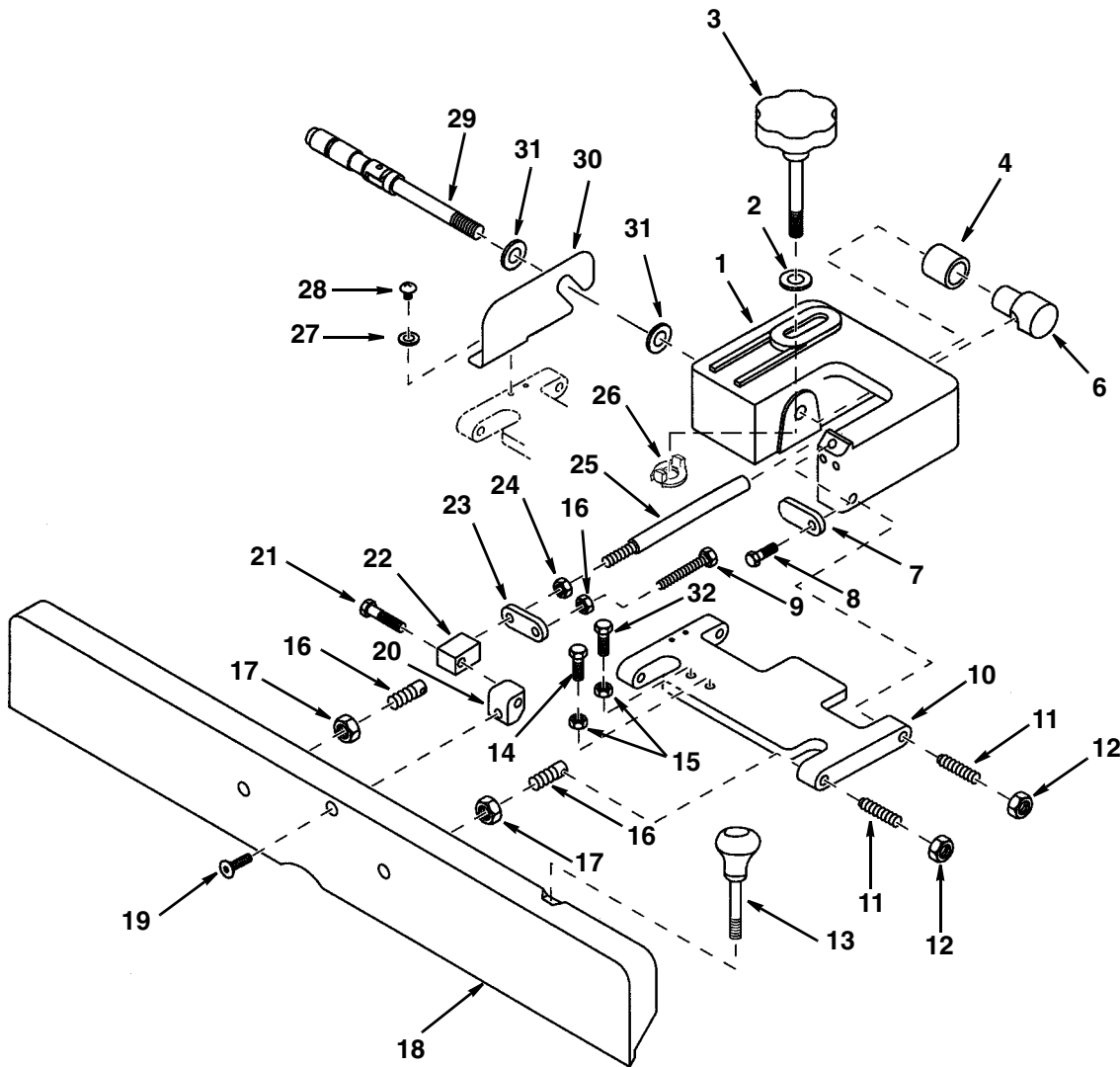

Repair Parts

Parts List for RIDGID 6-1/8" Jointer/Planer

Model No. JP06101

RIDGID parts are available on-line at www.ridgidparts.com

Figure 2

Always order by Part Number - Not by Key Number

Key No.	Part No.	Description
1	828689	Holder Fence
2	805563-6	* Washer .515 x 1-1/8 x 3/32
3	828400	Knob Fence
4	828517	Sleeve Fence
5		
6	828518	Nut Tee Fence
7	828524	Plate Stop
8	828522	Bolt Shoulder 9mm x 19mm
9	805467-11	* Screw Hex Hd 5/16-18 x 1-3/4
10	829507	Plate Fence Pivot
11	828516	Screw Pivot
12	118645	Nut Hex Jam 3/8-16
13	828712	Knob Fence Tilt
14	805467-6	* Screw Hex Hd 5/16-18 x 1
15	805482	* Nut Hex Jam 5/16-18
16	828447	Stud Pivot

Key No.	Part No.	Description
17	813640	* Nut Hex Jam 1/2-20
18	829506	Fence
19	805297-8	* Screw Flat Hd Soc 5/16-18 x 1-1/2
20	828520	Nut Handle
21	828525	Bolt Shoulder 10 x 6
22	828521	Nut Pivot
23	828519	Stop Fence
24	805485	* Nut Hex Jam 7/16-14
25	829508	Shaft Lock
26	828526	Collar Lock
27	805551-2	* Washer Flat 1/4 x 1/2 x 1/16
28	809491-5	* Screw Pan Cr 1/4-20 x 1/2
29	828401	Handle Asm
30	828529	Bracket Fence
31	805567-6	Washer .63 I.D. x 1-3/4 x 5/32
32	805467	* Screw Hex Hd 5/16-18 x 1-1/4

* Standard hardware item, may be purchased locally

Parts List for RIDGID 6-1/8" Jointer/Planer Model No. JP06101

RIDGID parts are available on-line at www.ridgidparts.com

Figure 3

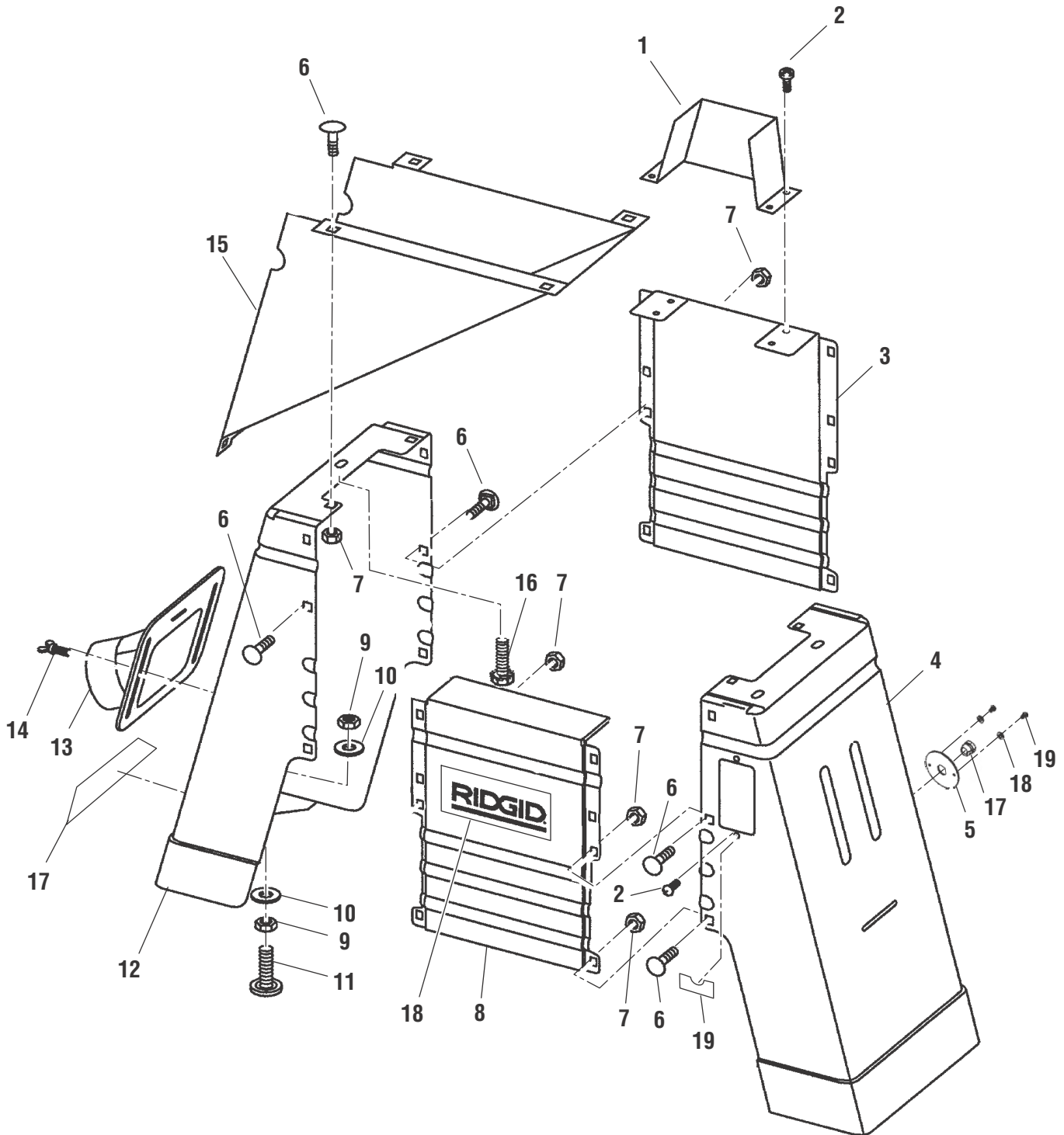

Repair Parts

Parts List for RIDGID 6-1/8" Jointer/Planer

Model No. JP06101

RIDGID parts are available on-line at www.ridgidparts.com

Figure 3

Always order by Part Number - Not by Key Number

Key No.	Part No.	Description
1	828577	Guard Pulley
2	826658	Screw Pan Cr Serr 3/16-24 x 3/8
3	828563	Panel Rear
4	828565	Panel Asm Right (Includes Key 5)
5	TH260021	Plate
6	827642-1	Bolt Rd Hd Sh Neck 5/16-18 x 1/2
7	826817-1	Nut Hex Flange 5/16-18
8	828562	Panel Asm Front

* Standard hardware item, may be purchased locally

Key No.	Part No.	Description
9	118615	* Nut Hex 3/8-16
10	820296-3	Washer 10mm I.D.
11	803835-3	Foot Leveling 3/8
12	828561	Panel Asm Left
13	828411	Chute Dust
14	826525	Screw Wing
15	828566	Bracket Motor
16	828412	Screw Hex Ser Fl 3/8-16 x 3/4
17	HN030900	Strain Relief
18	HE011200	Flat Washer 5.1 x 11.2 x 1.0T
19	HB040903	Screw 3/16-24 x 1/4 in. Pan Hd.

Parts List for RIDGID 6-1/8" Jointer/Planer

Model No. JP06101

RIDGID parts are available on-line at www.ridgidparts.com

Figure 4

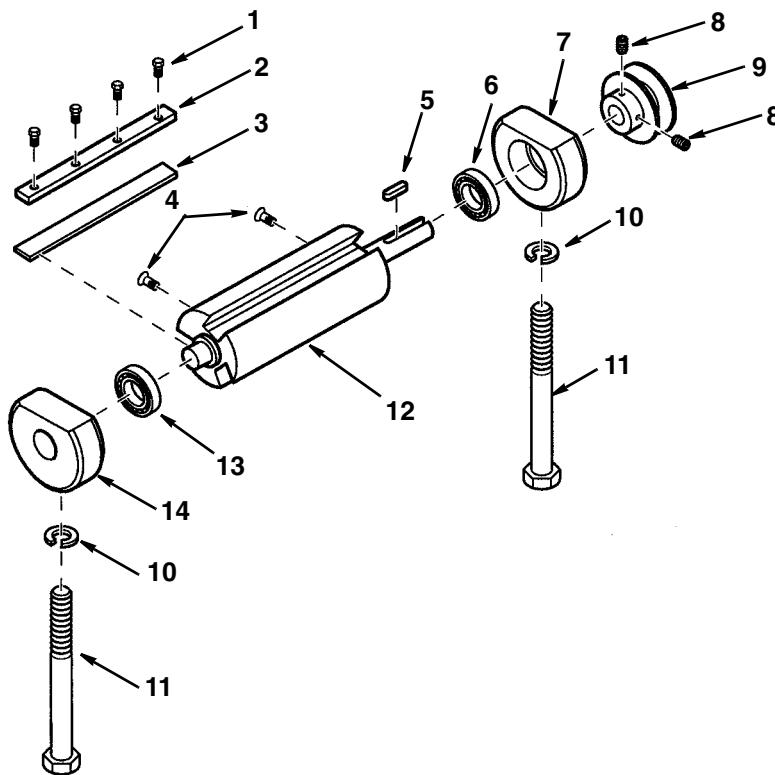

Always order by Part Number - Not by Key Number

Key No.	Part No.	Description
1	824886	Screw 1/4-28 x 7mm
2	824885	Wedge
3	AC8600	† Blade
4	821030	Screw Flat Hd Hex Soc M5 x 0.8-12
5	818654-7	Key
6	820722-5	Bearing
7	824881-1	Support Bearing

Key No.	Part No.	Description
8	160033-1	* Soc Set Screw 1/4-20 x 3/8
9	824888	Pulley
10	818826-8	* Lockwasher M10
11	824890	Screw Hex 3/8-24 x 3-1/2
12	828399	Cutter head
13	820722-6	Bearing
14	824879-1	Support Bearing

† These parts are available where you purchased your jointer.

Repair Parts

Parts List for RIDGID 6-1/8" Jointer/Planer Model No. JP06101

RIDGID parts are available on-line at www.ridgidparts.com

Figure 5

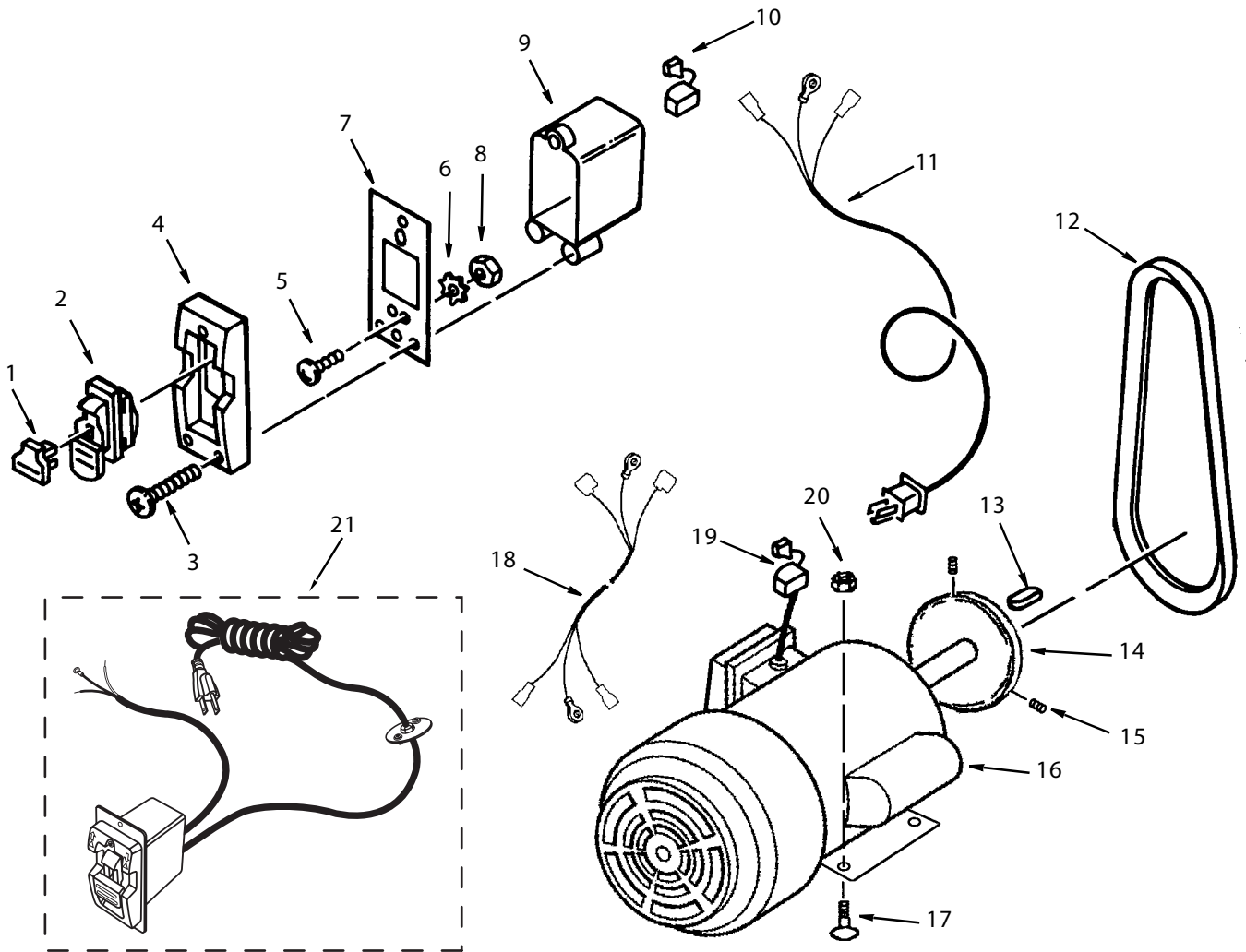

Always order by Part Number - Not by Key Number

Key No.	Part No.	Description
1	826122	Key Switch
2	826123	Switch Locking
3	817357-5	* Screw Ty AB M4 x 1.6-18
4	826395	Bezel Switch
5	808275-4	* Screw Pan Hd #8-32 x 3/8
6	138164	* Lockwasher #8
7	826653	Plate Switch Bezel
8	805475	* Nut #8-32
9	824914	Box Switch
10	169123-15	Strain Relief 6P3-4

* Standard hardware item, may be purchased locally

Key No.	Part No.	Description
11	824911-1	Cord w/Plug
12	817393-7	V-Belt A-36
13	818654-8	Key
14	824931	Pulley
15	160033-1	Screw Set 1/4-20 x 3/8
16	828530	Motor
17	827642-1	* Bolt Rd Hd Sh 5/16-18 x 1/2
18	824915-1	Cord Motor
19	69164	Strain Relief 6N3-4
20	826817-1	Nut
21	JEG6	Switch Assembly, with Cords and Cord Plate

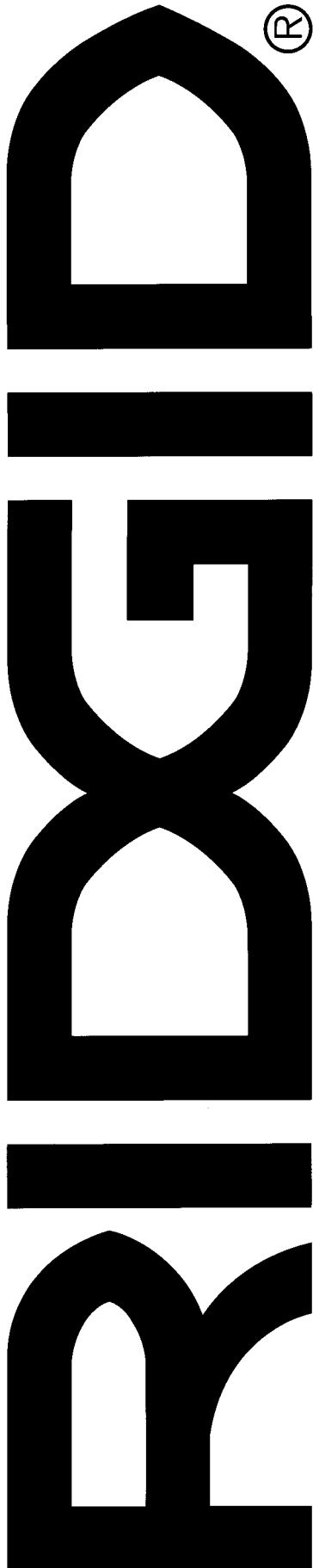

One World Technologies, Inc.
Hwy. 8
Pickens, SC 29671

Part No. SP6442

RIDGID™ HAND HELD AND STATIONARY POWER TOOL LIMITED THREE YEAR WARRANTY AND 90-DAY SATISFACTION GUARANTEE POLICY

This product is manufactured by One World Technologies, Inc., under a trademark license from Ridgid, Inc. All warranty communications should be directed to One World Technologies, Inc., attn: RIDGID handheld and stationary power tool technical service at (toll free) 1-866-539-1710.

90-DAY SATISFACTION GUARANTEE POLICY

During the first 90 days after the date of purchase, if you are dissatisfied with the performance of this RIDGID tool for any reason you may return the tool to the dealer from which it was purchased for a full refund or exchange. To receive a replacement tool you must present proof of purchase and return all original equipment packaged with the original product. The replacement tool will be covered by the limited warranty for the balance of the three year warranty period.

WHAT IS COVERED UNDER THE LIMITED THREE YEAR WARRANTY

This warranty covers all defects in workmanship or materials in this RIDGID tool for the three year period from the date of purchase. This warranty is specific to this tool. Warranties for other RIDGID products may vary.

HOW TO OBTAIN SERVICE

To obtain service for this RIDGID tool you must return it, freight prepaid, to an authorized RIDGID service center for hand held and stationary power tools. You may obtain the location of the authorized service center nearest you by calling (toll free) 1-866-539-1710 or by logging on to the RIDGID website at www.ridgid.com. When requesting warranty service, you must present the proof of purchase documentation, which includes a date of purchase. The authorized service center will repair any faulty workmanship, and either repair or replace any defective part, at our option at no charge to you.

WHAT IS NOT COVERED

This warranty applies only to the original purchaser at retail and may not be transferred. This warranty only covers defects arising under normal usage and does not cover any malfunction, failure or defect resulting from misuse, abuse, neglect, alteration, modification or repair by other than an authorized service center for RIDGID branded hand held and stationary power tools. RIDGID, INC. AND ONE WORLD TECHNOLOGIES, INC. MAKE NO WARRANTIES, REPRESENTATIONS OR PROMISES AS TO THE QUALITY OR PERFORMANCE OF ITS POWER TOOLS OTHER THAN THOSE SPECIFICALLY STATED IN THIS WARRANTY.

ADDITIONAL LIMITATIONS

To the extent permitted by applicable law, all implied warranties, including warranties of MERCHANTABILITY or FITNESS FOR A PARTICULAR PURPOSE, are disclaimed. Any implied warranties, including warranties of merchantability or fitness for a particular purpose, that cannot be disclaimed under state law are limited to three years from the date of purchase. One World Technologies, Inc. is not responsible for direct, indirect, incidental or consequential damages. Some states do not allow limitations on how long an implied warranty lasts and/or do not allow the exclusion or limitation of incidental or consequential damages, so the above limitations may not apply to you. This warranty gives you specific legal rights, and you may also have other rights which vary from state to state.

Stock No. JP0610

Model No. JP06101

Serial No. _____ Model and serial numbers may be found on a plate attached to the base. You should record serial number in a safe place for future use.

QUESTIONS OR COMMENTS?

CALL 1-866-539-1710

www.ridgid.com

Please have your Model Number and Serial Number on hand when calling.

Form No. SP6442

Free Manuals Download Website

<http://myh66.com>

<http://usermanuals.us>

<http://www.somanuals.com>

<http://www.4manuals.cc>

<http://www.manual-lib.com>

<http://www.404manual.com>

<http://www.luxmanual.com>

<http://aubethermostatmanual.com>

Golf course search by state

<http://golfingnear.com>

Email search by domain

<http://emailbydomain.com>

Auto manuals search

<http://auto.somanuals.com>

TV manuals search

<http://tv.somanuals.com>