



# OPERATOR'S MANUAL

1/2 in. HAMMER DRILL  
VARIABLE SPEED

DOUBLE INSULATED

D551H

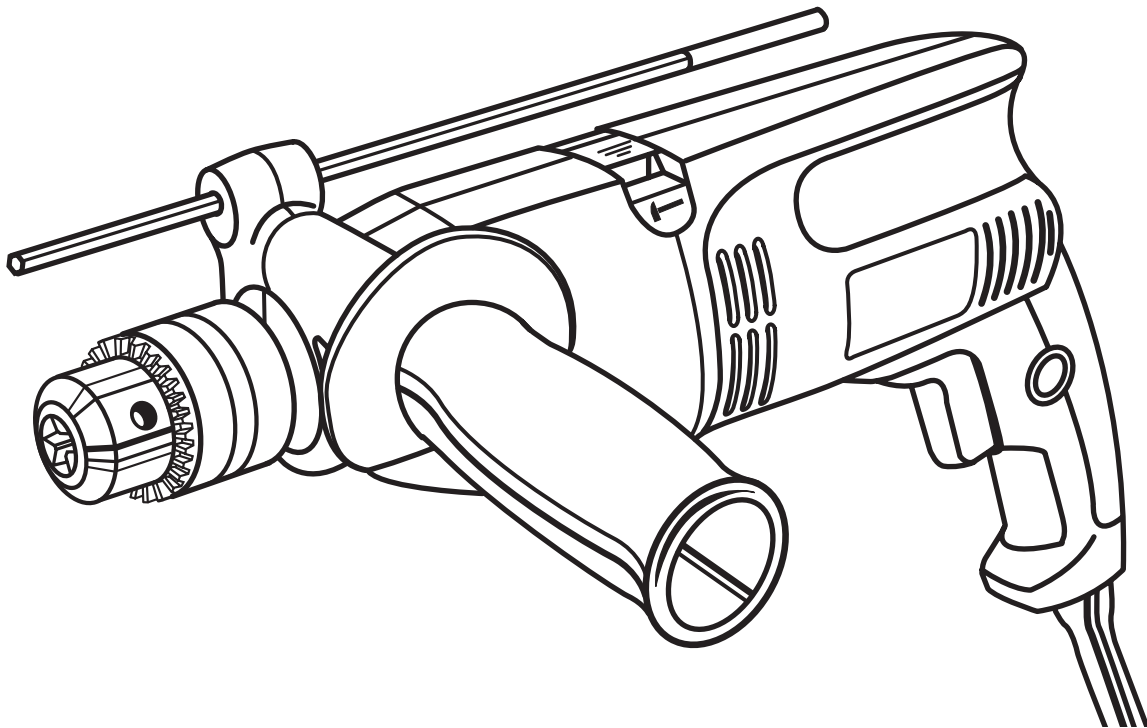

Your hammer drill has been engineered and manufactured to Ryobi's high standard for dependability, ease of operation, and operator safety. When properly cared for, it will give you years of rugged, trouble-free performance.

**⚠ WARNING:** To reduce the risk of injury, the user must read and understand the operator's manual before using this product.

Thank you for buying a Ryobi product.

**SAVE THIS MANUAL FOR FUTURE REFERENCE**

# TABLE OF CONTENTS

■ Introduction .....	2
■ General Safety Rules .....	3-4
■ Specific Safety Rules .....	4
■ Symbols .....	5-6
■ Electrical .....	7
■ Features .....	8-9
■ Assembly .....	10
■ Operation .....	10-14
■ Maintenance .....	14-15
■ Parts Ordering / Service .....	16

## INTRODUCTION

This tool has many features for making its use more pleasant and enjoyable. Safety, performance, and dependability have been given top priority in the design of this product making it easy to maintain and operate.

# GENERAL SAFETY RULES



## WARNING:

Read and understand all instructions. Failure to follow all instructions listed below, may result in electric shock, fire and/or serious personal injury.

## SAVE THESE INSTRUCTIONS

### WORK AREA

- **Keep your work area clean and well lit.** Cluttered benches and dark areas invite accidents.
- **Do not operate power tools in explosive atmospheres, such as in the presence of flammable liquids, gases, or dust.** Power tools create sparks which may ignite the dust or fumes.
- **Keep bystanders, children, and visitors away while operating a power tool.** Distractions can cause you to lose control.

### ELECTRICAL SAFETY

- **Double insulated tools are equipped with a polarized plug (one blade is wider than the other). This plug will fit in a polarized outlet only one way. If the plug does not fit fully in the outlet, reverse the plug. If it still does not fit, contact a qualified electrician to install a polarized outlet. Do not change the plug in any way.** Double insulation  eliminates the need for the three-wire grounded power cord and grounded power supply system.
- **Avoid body contact with grounded surfaces such as pipes, radiators, ranges, and refrigerators.** There is an increased risk of electric shock if your body is grounded.
- **Don't expose power tools to rain or wet conditions.** Water entering a power tool will increase the risk of electric shock.
- **Do not abuse the cord. Never use the cord to carry the tools or pull the plug from an outlet. Keep cord away from heat, oil, sharp edges, or moving parts. Replace damaged cords immediately.** Damaged cords increase the risk of electric shock.
- **When operating a power tool outside, use an outdoor extension cord marked "W-A" or "W".** These cords are rated for outdoor use and reduce the risk of electric shock.

### PERSONAL SAFETY

- **Stay alert, watch what you are doing and use common sense when operating a power tool. Do not use tool while tired or under the influence of drugs, alcohol, or medication.** A moment of inattention while operating power tools may result in serious personal injury.
- **Dress properly. Do not wear loose clothing or jewelry. Contain long hair. Keep your hair, clothing, and gloves away from moving parts.** Loose clothes, jewelry, or long hair can be caught in moving parts.

- **Avoid accidental starting. Be sure switch is off before plugging in.** Carrying tools with your finger on the switch or plugging in tools that have the switch on invites accidents.
- **Remove adjusting keys or wrenches before turning the tool on.** A wrench or a key that is left attached to a rotating part of the tool may result in personal injury.
- **Do not overreach. Keep proper footing and balance at all times.** Proper footing and balance enables better control of the tool in unexpected situations.
- **Use safety equipment. Always wear eye protection.** Dust mask, nonskid safety shoes, hard hat, or hearing protection must be used for appropriate conditions.
- **Do not wear loose clothing or jewelry. Contain long hair.** Loose clothes, jewelry, or long hair can be drawn into air vents.
- **Do not use on a ladder or unstable support.** Stable footing on a solid surface enables better control of the tool in unexpected situations.

### TOOL USE AND CARE

- **Use clamps or other practical way to secure and support the workpiece to a stable platform.** Holding the work by hand or against your body is unstable and may lead to loss of control.
- **Do not force tool. Use the correct tool for your application.** The correct tool will do the job better and safer at the rate for which it is designed.
- **Do not use tool if switch does not turn it on or off.** Any tool that cannot be controlled with the switch is dangerous and must be repaired.
- **Disconnect the plug from power source before making any adjustments, changing accessories, or storing the tool.** Such preventive safety measures reduce the risk of starting the tool accidentally.
- **Store idle tools out of the reach of children and other untrained persons.** Tools are dangerous in the hands of untrained users.
- **Maintain tools with care. Keep cutting tools sharp and clean.** Properly maintained tools with sharp cutting edges are less likely to bind and are easier to control.
- **Check for misalignment or binding of moving parts, breakage of parts, and any other condition that may affect the tool's operation. If damaged, have the tool serviced before using.** Many accidents are caused by poorly maintained tools.
- **Use only accessories that are recommended by the manufacturer for your model.** Accessories that may be suitable for one tool, may become hazardous when used on another tool.
- **Keep the tool and its handle dry, clean and free from oil and grease.** Always use a clean cloth when cleaning. Never use brake fluids, gasoline, petroleum-based products, or any strong solvents to clean your tool. Following this rule will reduce the risk of loss of control and deterioration of the enclosure plastic.

# GENERAL SAFETY RULES

## SERVICE

- **Tool service must be performed only by qualified repair personnel.** Service or maintenance performed by unqualified personnel may result in a risk of injury.
- **When servicing a tool, use only identical replacement parts. Follow instructions in the Maintenance section of this manual.** Use of unauthorized parts or failure to follow Maintenance Instructions may create a risk of shock or injury.

# SPECIFIC SAFETY RULES

- **Hold tool by insulated gripping surfaces when performing an operation where the cutting tool may contact hidden wiring or its own cord.** Contact with a “live” wire will make exposed metal parts of the cutting tool “live” and shock the operator.
- **Know your power tool. Read operator’s manual carefully. Learn its applications and limitations, as well as the specific potential hazards related to this tool.** Following this rule will reduce the risk of electric shock, fire, or serious injury.
- **Always wear safety glasses. Everyday eyeglasses have only impact-resistant lenses; they are NOT safety glasses.** Following this rule will reduce the risk of serious personal injury.
- **Protect your lungs. Wear a face or dust mask if the operation is dusty.** Following this rule will reduce the risk of serious personal injury.
- **Protect your hearing. Wear hearing protection during extended periods of operation.** Following this rule will reduce the risk of serious personal injury.
- **Inspect tool cords periodically and, if damaged, have repaired at your nearest Authorized Service Center. Constantly stay aware of cord location.** Following this rule will reduce the risk of electric shock or fire.
- **Check damaged parts. Before further use of the tool, a guard or other part that is damaged should be carefully checked to determine that it will operate properly and perform its intended function. Check for alignment of moving parts, binding of moving parts, breakage of parts, mounting, and any other conditions that may affect its operation. A guard or other part that is damaged should be properly repaired or replaced by an authorized service center.** Following this rule will reduce the risk of shock, fire, or serious injury.
- **Make sure your extension cord is in good condition. When using an extension cord, be sure to use one heavy enough to carry the current your product will draw. A wire gauge size (A.W.G.) of at least 14 is recommended for an extension cord 50 feet or less in length. A cord exceeding 100 feet is not recommended. If in doubt, use the next heavier gauge. The smaller the gauge number, the heavier the cord. An undersized cord will cause a drop in line voltage resulting in loss of power and overheating.**
- **Inspect for and remove all nails from lumber before using this tool.** Following this rule will reduce the risk of serious personal injury.
- **Save these instructions.** Refer to them frequently and use them to instruct others who may use this tool. If you loan someone this tool, loan them these instructions also.

## WARNING:











Some dust created by power sanding, sawing, grinding, drilling, and other construction activities contains chemicals known to cause cancer, birth defects or other reproductive harm. Some examples of these chemicals are:

- lead from lead-based paints,
- crystalline silica from bricks and cement and other masonry products, and
- arsenic and chromium from chemically-treated lumber.

Your risk from these exposures varies, depending on how often you do this type of work. To reduce your exposure to these chemicals: work in a well ventilated area, and work with approved safety equipment, such as those dust masks that are specially designed to filter out microscopic particles.



# SYMBOLS

Some of the following symbols may be used on this tool. Please study them and learn their meaning. Proper interpretation of these symbols will allow you to operate the tool better and safer.

SYMBOL	NAME	DESIGNATION/EXPLANATION
V	Volts	Voltage
A	Amperes	Current
Hz	Hertz	Frequency (cycles per second)
W	Watt	Power
min	Minutes	Time
~	Alternating Current	Type of current
==	Direct Current	Type or a characteristic of current
$n_0$	No Load Speed	Rotational speed, at no load
	Class II Construction	Double-insulated construction
.../min	Per Minute	Revolutions, strokes, surface speed, orbits etc., per minute
	Wet Conditions Alert	Do not expose to rain or use in damp locations.
	Read The Operator's Manual	To reduce the risk of injury, user must read and understand operator's manual before using this product.
	Eye Protection	Always wear safety goggles or safety glasses with side shields, or a full face shield when operating this product.
	Safety Alert	Precautions that involve your safety.
	No Hands Symbol	Failure to keep your hands away from the blade will result in serious personal injury.
	No Hands Symbol	Failure to keep your hands away from the blade will result in serious personal injury.
	No Hands Symbol	Failure to keep your hands away from the blade will result in serious personal injury.
	No Hands Symbol	Failure to keep your hands away from the blade will result in serious personal injury.
	Hot Surface	To reduce the risk of injury or damage, avoid contact with any hot surface.

# SYMBOLS

The following signal words and meanings are intended to explain the levels of risk associated with this product.

SYMBOL	SIGNAL	MEANING
	<b>DANGER:</b>	Indicates an imminently hazardous situation, which, if not avoided, will result in death or serious injury.
	<b>WARNING:</b>	Indicates a potentially hazardous situation, which, if not avoided, could result in death or serious injury.
	<b>CAUTION:</b>	Indicates a potentially hazardous situation, which, if not avoided, may result in minor or moderate injury.
	<b>CAUTION:</b>	(Without Safety Alert Symbol) Indicates a situation that may result in property damage.

## SERVICE

Servicing requires extreme care and knowledge and should be performed only by a qualified service technician. For service we suggest you return the product to your nearest **AUTHORIZED SERVICE CENTER** for repair. When servicing, use only identical replacement parts.



### **WARNING:**

To avoid serious personal injury, do not attempt to use this product until you read thoroughly and understand completely the operator's manual. Save this operator's manual and review frequently for continuing safe operation and instructing others who may use this product.

### **WARNING:**



The operation of any power tool can result in foreign objects being thrown into your eyes, which can result in severe eye damage. Before beginning power tool operation, always wear safety goggles or safety glasses with side shields, or a full face shield when needed. We recommend Wide Vision Safety Mask for use over eyeglasses or standard safety glasses with side shields. Always use eye protection which is marked to comply with ANSI Z87.1.

## SAVE THESE INSTRUCTIONS

# ELECTRICAL

## DOUBLE INSULATION

Double insulation is a concept in safety in electric power tools, which eliminates the need for the usual three-wire grounded power cord. All exposed metal parts are isolated from the internal metal motor components with protecting insulation. Double insulated tools do not need to be grounded.

### **WARNING:**

The double insulated system is intended to protect the user from shock resulting from a break in the tool's internal insulation. Observe all normal safety precautions to avoid electrical shock.

**NOTE:** Servicing of a tool with double insulation requires extreme care and knowledge of the system and should be performed only by a qualified service technician. For service, we suggest you return the tool to your nearest authorized service center for repair. Always use original factory replacement parts when servicing.

## ELECTRICAL CONNECTION

This tool has a precision-built electric motor. It should be connected to a **power supply that is 120 volts, 60 Hz, AC only (normal household current)**. Do not operate this tool on direct current (DC). A substantial voltage drop will cause a loss of power and the motor will overheat. If your tool does not operate when plugged into an outlet, double-check the power supply.

## EXTENSION CORDS

When using a power tool at a considerable distance from a power source, be sure to use an extension cord that has the capacity to handle the current the tool will draw. An undersized cord will cause a drop in line voltage, resulting in overheating and loss of power. Use the chart to determine the minimum wire size required in an extension cord. Only round jacketed cords listed by Underwriter's Laboratories (UL) should be used.

When working outdoors with a tool, use an extension cord that is designed for outside use. This type of cord is designated with "WA" on the cord's jacket.

Before using any extension cord, inspect it for loose or exposed wires and cut or worn insulation.

\*\*Ampere rating (on tool data plate)

Cord Length	Wire Size (A.W.G.)					
	0-2.0	2.1-3.4	3.5-5.0	5.1-7.0	7.1-12.0	12.1-16.0
25'	16	16	16	16	14	14
50'	16	16	16	14	14	12
100'	16	16	14	12	10	—

\*\*Used on 12 gauge - 20 amp circuit.

**NOTE:** AWG = American Wire Gauge

### **WARNING:**

Keep the extension cord clear of the working area. Position the cord so that it will not get caught on lumber, tools or other obstructions while you are working with a power tool. Failure to do so can result in serious personal injury.

### **WARNING:**

Check extension cords before each use. If damaged replace immediately. Never use tool with a damaged cord since touching the damaged area could cause electrical shock resulting in serious injury.

# FEATURES

## PRODUCT SPECIFICATIONS

Chuck Capacity .....	5/64 in. - 1/2 in.
Hammer Speed .....	Low (0 - 16,000 BPM*) High (0 - 48,000 BPM*)
No Load Speed .....	Low (0 - 1,000/min.) High (0 - 3,000/min.)
Input .....	120 V, 60 Hz, AC only, 5.5 Amps
Net Weight.....	5.75 lbs.

\*Blows Per Minute

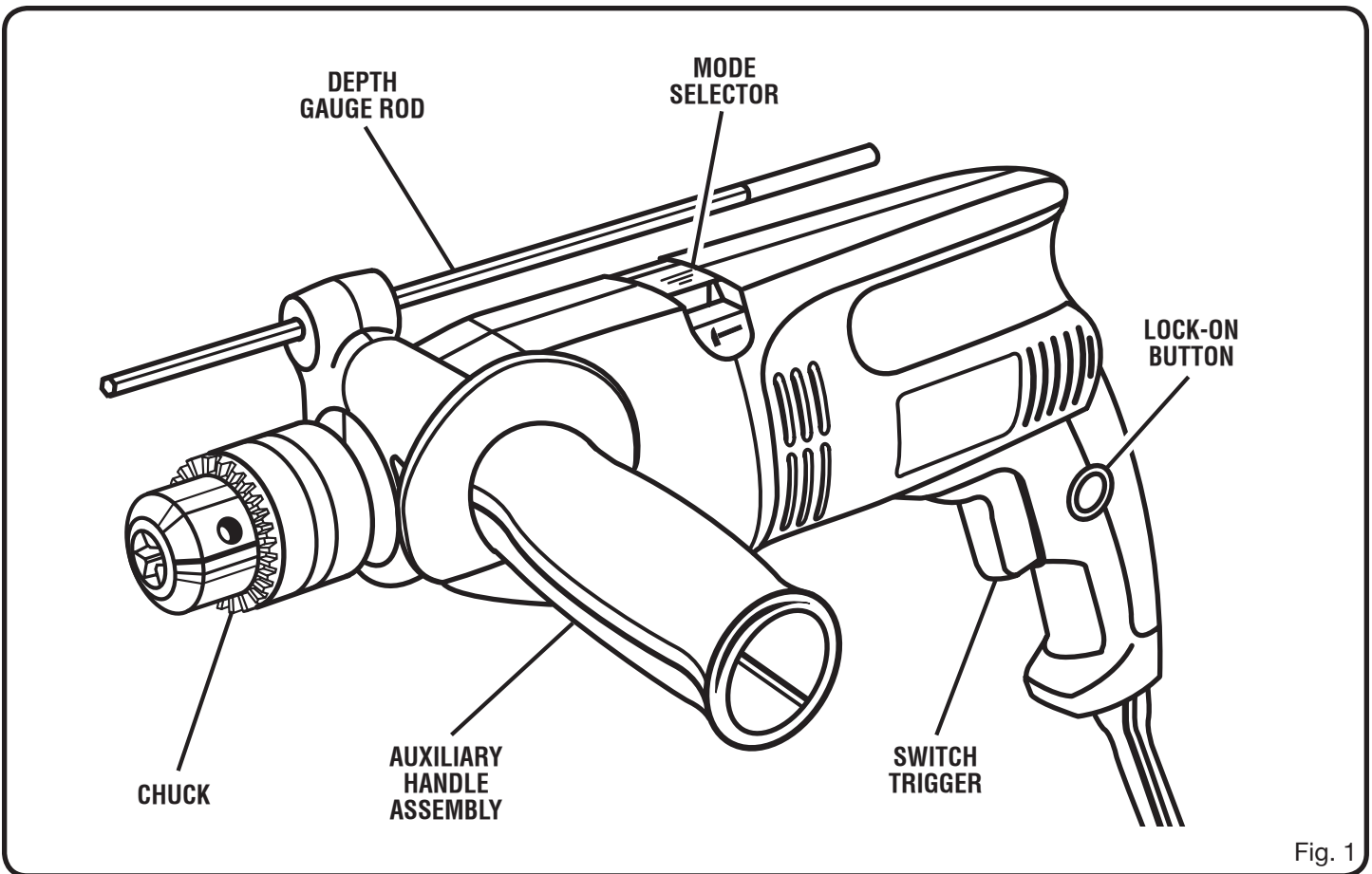

Fig. 1



# FEATURES

## **KNOW YOUR HAMMER DRILL**

*See Figure 1.*

Before attempting to use this product, familiarize yourself with all operating features and safety rules.

## **AUXILIARY HANDLE ASSEMBLY**

An auxiliary handle assembly is installed on the hammer drill. For ease of operation, you may use the handle with either your left hand or your right hand.

## **CHUCK KEY**

A chuck key is provided for use when installing or removing bits. It is also used when removing the chuck.

## **DEPTH GAUGE ROD**

A depth gauge rod is installed on the hammer drill to assist you in controlling the depth of drilled holes.

## **ERGONOMIC DESIGN**

This hammer drill is designed for comfort and ease of grasp when operating in different positions and at different angles.

## **GRIPZONE™ OVERMOLD TECHNOLOGY**

The hammer drill features Gripzone™ overmold technology for improved comfort with a positive grip.

## **LOCK-ON BUTTON**

The hammer drill contains a lock-on feature that allows you to lock the drill on when you operate it continuously for extended periods of time.

## **MODE SELECTOR**

You can change the drill mode depending on the type of material in which you are drilling.

## **REVERSIBLE**

This hammer drill allows you to reverse the drill rotation. You can control the direction of the chuck with a lever located above the switch trigger.

## **SWITCH TRIGGER**

The hammer drill has a conveniently located switch trigger.

## **VARIABLE SPEED**

This tool has a variable speed switch that delivers higher speed with increased trigger pressure. Speed is controlled by the amount of switch trigger depression.

# ASSEMBLY

## UNPACKING

This product has been shipped completely assembled.

- Carefully remove the tool and any accessories from the box. Make sure that all items listed in the packing list are included.
- Inspect the tool carefully to make sure no breakage or damage occurred during shipping.
- Do not discard the packing material until you have carefully inspected and satisfactorily operated the tool.
- If any parts are damaged or missing, please call 1-800-525-2579 for assistance.

## PACKING LIST

Hammer Drill

Carrying Case

Operator's Manual

Warranty Registration Card

### **WARNING:**

If any parts are missing do not operate this tool until the missing parts are replaced. Failure to heed this warning could result in possible serious personal injury.

### **WARNING:**

Do not attempt to modify this tool or create accessories not recommended for use with this tool. Any such alteration or modification is misuse and could result in a hazardous condition leading to possible serious personal injury.

### **WARNING:**

Do not connect to power supply until assembly is complete. Failure to comply could result in accidental starting and possible serious personal injury.

# OPERATION

### **WARNING:**

Do not allow familiarity with tools to make you careless. Remember that a careless fraction of a second is sufficient to inflict serious injury.

### **WARNING:**

Always wear safety goggles or safety glasses with side shields when operating power tools. Failure to do so could result in objects being thrown into your eyes resulting in possible serious injury.

### **WARNING:**

Do not use any attachments or accessories not recommended by the manufacturer of this tool. The use of attachments or accessories not recommended can result in serious personal injury.

## APPLICATIONS

You may use this tool for the purposes listed below:

- Hammer drilling in concrete, brick, or other masonry
- Drilling in wood
- Drilling in ceramics, plastics, fiberglass, and laminates
- Drilling in both soft and hard metals
- Using driving accessories such as driving screws with screwdriver bits
- Mixing paint

# OPERATION

## **⚠ WARNING:**

Always unplug the drill before inserting or removing bits or adjusting the auxiliary handle assembly or depth gauge rod. Failure to unplug the tool could result in accidental starting causing possible serious injury.

## **INSERTING BITS**

See Figure 2.

- Unplug the hammer drill.
- Position the chuck jaws so that the opening is slightly larger than the drill bit you intend to use.  
**NOTE:** To open the chuck jaws, turn the chuck collar counterclockwise. To close the chuck jaws, turn the chuck collar clockwise.
- Raise the front of the drill to keep the drill bit from falling out of the chuck jaws.

## **⚠ WARNING:**

Do not insert a drill bit into the chuck jaws and tighten as shown in Figure 3. This could cause the drill bit to be thrown from the drill, resulting in possible serious injury or damage to the chuck.

- Insert the drill bit completely into the chuck.
- Tighten the chuck jaws securely on the drill bit using the chuck key provided. Do not use a wrench to tighten or loosen the chuck jaws.

## **REMOVING BITS**

- Unplug the hammer drill.
- Loosen the chuck jaws using the chuck key provided.
- Remove the drill bit from the chuck jaws.

## **ADJUSTING THE AUXILIARY HANDLE ASSEMBLY**

See Figure 4.

- Unplug the hammer drill.
- Loosen the handle assembly by turning the handle counterclockwise.
- Remove the handle from the drill.
- Rotate the handle assembly and place it on the opposite side.
- Tighten the handle assembly securely by turning the handle clockwise.

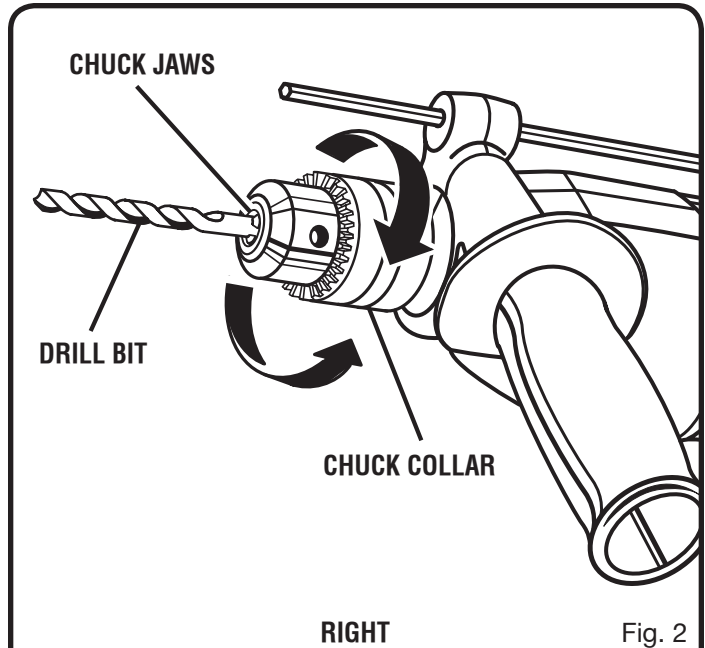

Fig. 2

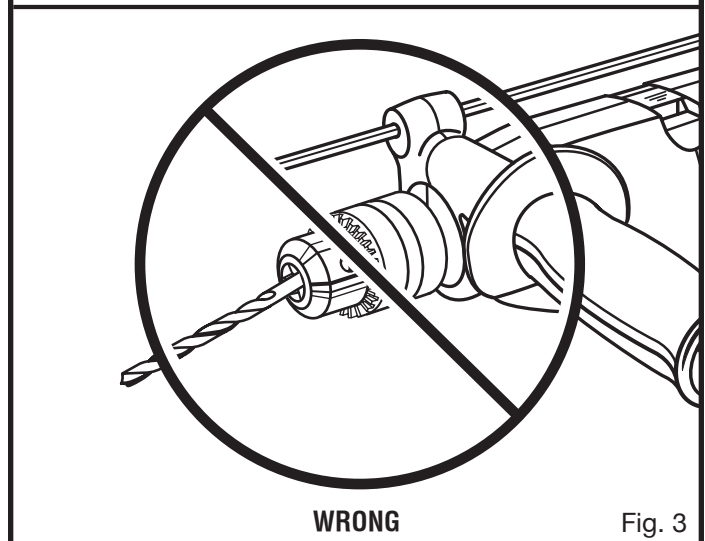

Fig. 3

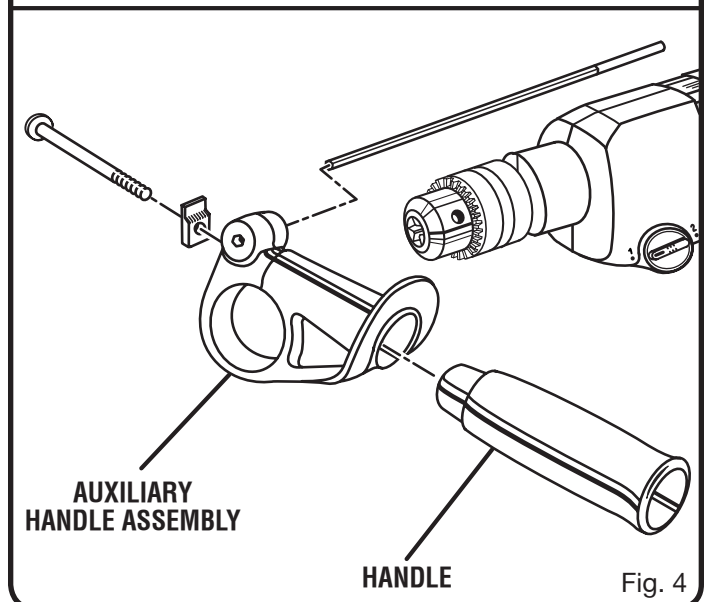

Fig. 4

# OPERATION

## ADJUSTING THE DEPTH GAUGE ROD

See Figure 5.

- Unplug the hammer drill.
- Loosen the handle assembly by turning the handle counterclockwise.
- Adjust the depth gauge rod so that the drill bit extends beyond the end of the rod to the required drilling depth.
- Tighten handle assembly by turning handle clockwise.

## ADJUSTING THE DRILL MODE

See Figure 6.

Use carbide-tipped bits and select hammer mode when drilling in hard materials such as brick, tile, concrete, etc.

Select drill mode when drilling in soft materials.

- For hammer mode: slide the mode selector to the left.
- For drill mode: slide the mode selector to the right.

## ADJUSTING THE SPEED

See Figure 7.

### CAUTION:

Never change gears while the tool is running. Failure to obey this caution could result in serious damage to the drill.

The hammer drill has a two-speed knob that provides a high speed of approximately 3,000 RPM and a low speed of approximately 1,000 RPM (stated speeds are with the trigger switch in the "Full-on" position).

- For high speed: Rotate the two-speed knob clockwise, aligning the indicator mark with the "2."
- For low speed: Rotate the two-speed knob counterclockwise, aligning the indicator mark with the "1."

If you have difficulty changing from one gear range to the other, turn the chuck by hand until the gears engage.

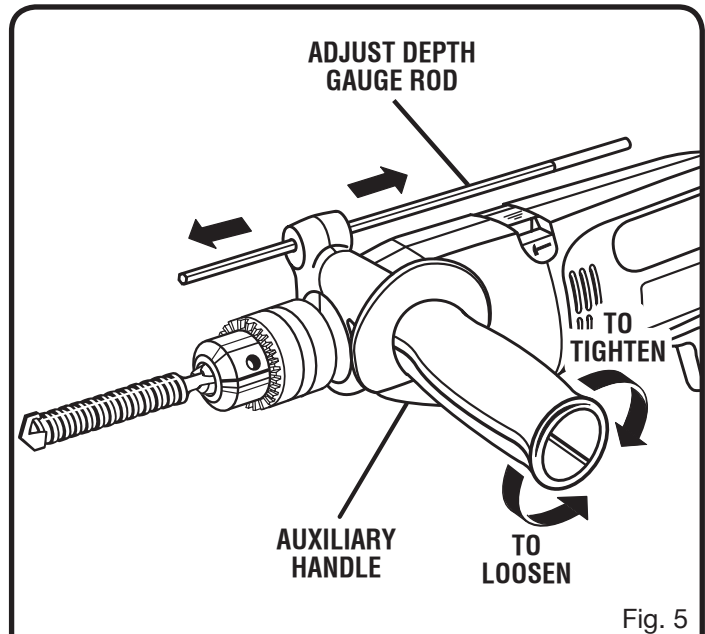

Fig. 5

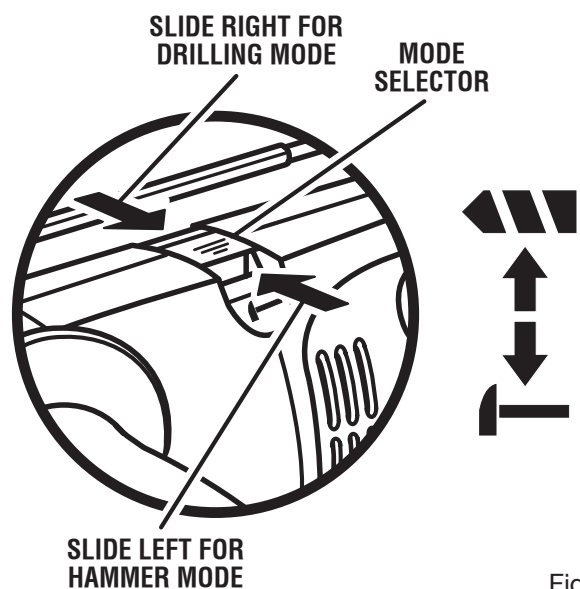

Fig. 6

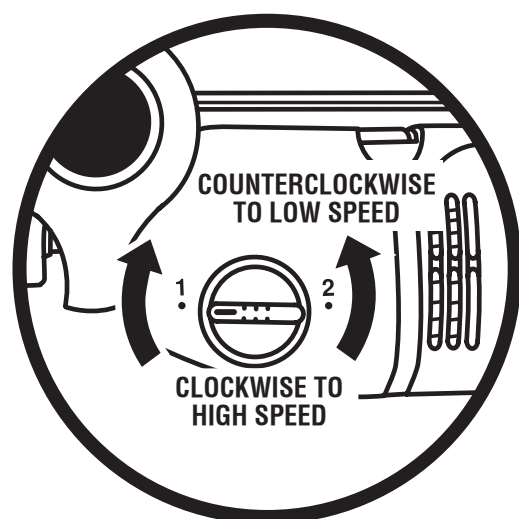

Fig. 7

# OPERATION

## TURNING THE HAMMER DRILL ON/OFF

See Figure 8.

To turn the hammer drill on and off.

- To turn the drill on: depress the switch trigger.
- To turn the drill off: release the switch trigger.

## CHANGING THE ROTATION

See Figure 9.

The direction of the chuck is controlled by the lever located above the switch trigger.

**NOTE:** The design of the switch will not permit changing the direction of rotation while the drill is running. Release the switch trigger and allow the drill to stop before changing its direction.

- For forward rotation: Move the lever to the left.
- For reverse rotation: Move the lever to the right.

**NOTE:** The hammer drill will not run unless the lever is pushed fully to the left or right.

### CAUTION:

The hammer drill is not designed for reverse hammering. Failure to heed this caution may result in damage to the drill.

## LOCKING ON

See Figure 10.

The lock-on feature allows you to lock the drill on when you operate it continuously for extended periods of time. If you have the “lock-on” feature engaged during use and the drill is disconnected from the power supply, disengage the “lock-on” feature immediately. Also, do not lock the trigger switch if you might need to suddenly stop the drill.

### WARNING:

Before connecting the hammer drill to a power supply, make sure it is not in the “locked-on” position. Failure to do so could result in accidental starting of the drill resulting in possible serious injury.

To lock on:

- Depress the switch trigger.
- Push in the lock-on button.
- Release the switch trigger.
- Release the lock-on button.

**NOTE:** To release the lock, depress the switch trigger.

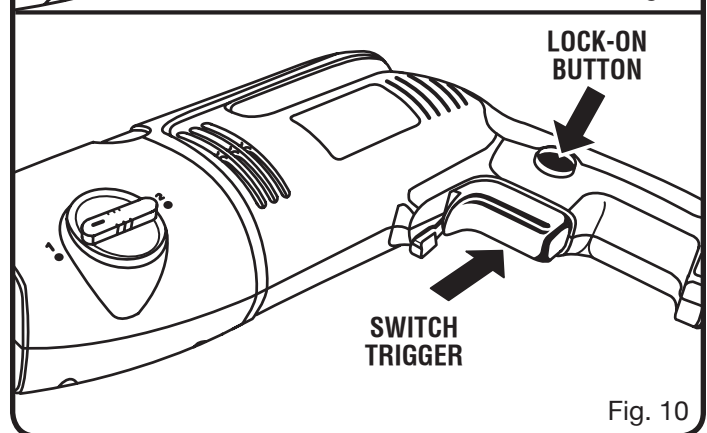
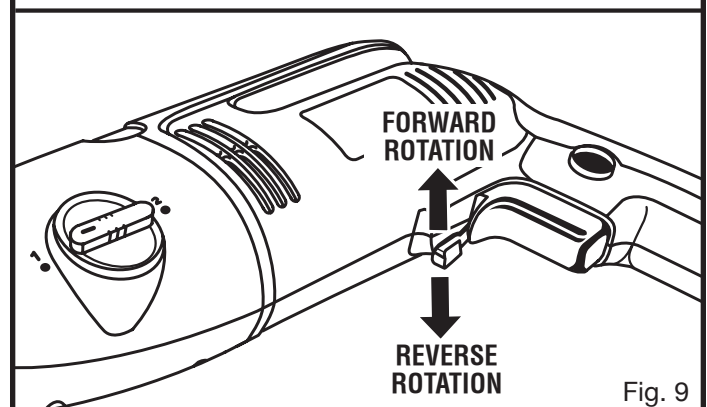
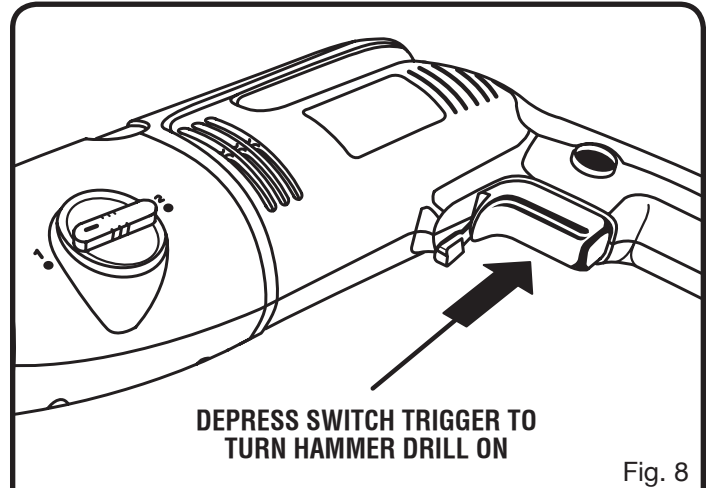

# OPERATION

## DRILLING

See Figure 11.

- Depress and release the switch trigger to make sure the drill is in the OFF position before connecting it to a power supply.
- Check the rotation lever for the correct setting. Refer to “CHANGING THE ROTATION” earlier in this manual.
- Secure the material to be drilled in a vise or with clamps to keep it from turning as the drill bit rotates.
- Plug the hammer drill into a power supply.
- Hold the drill firmly and place the bit at the point to be drilled.
- Depress the switch trigger to start the drill.
- Move the drill bit into the workpiece, applying only enough pressure to keep the bit cutting.

**NOTE:** Do not force the drill or apply side pressure to elongate a hole. Let your drill and bit do the work.

### **⚠ WARNING:**

Be prepared for binding at bit breakthrough. When these situations occur, the drill has a tendency to grab and kick in the opposite direction and could cause loss of control when breaking through material. If you are not prepared, this loss of control could result in possible serious injury.

## HELPFUL TIPS

- When drilling hard, smooth surfaces, use a center punch to mark the desired hole location. This measure will prevent the drill bit from slipping off center as you start the hole. However, the variable speed feature allows you to start holes without center punching. To accomplish this, operate the drill at a low speed until you start the hole.

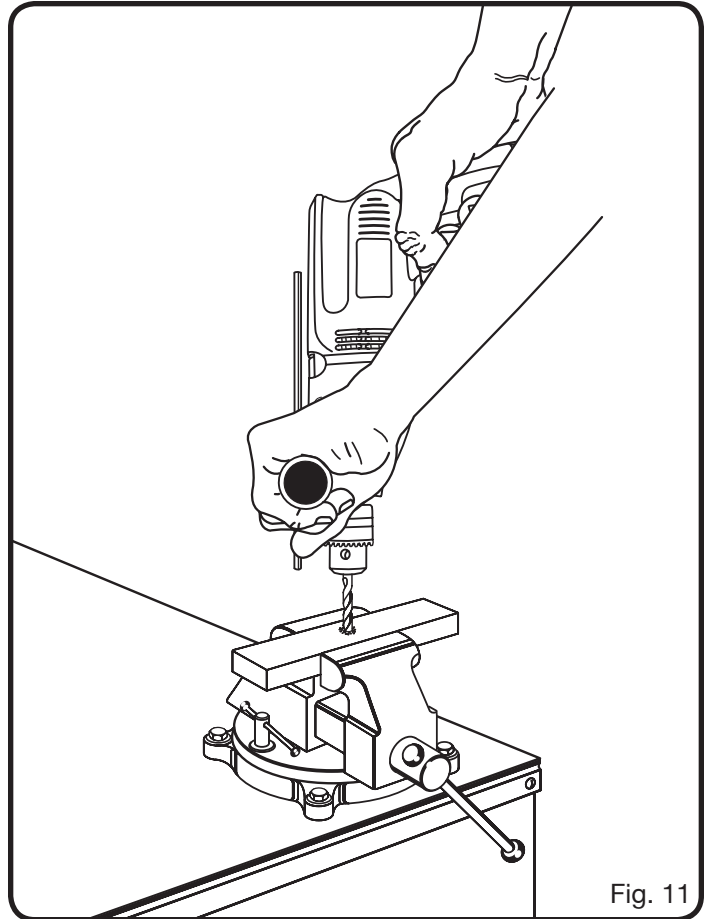

Fig. 11

- When drilling metals, use a light oil on the drill to keep it from overheating. The oil will prolong the life of the bit and increase the drilling action.
- If the bit jams in the workpiece or if the drill stalls, stop the tool immediately. Remove the bit from the workpiece and determine the reason for jamming.

# MAINTENANCE

### **⚠ WARNING:**

When servicing, use only identical Ryobi replacement parts. Use of any other parts may create a hazard or cause product damage.

### **⚠ WARNING:**

Always wear safety goggles or safety glasses with side shields during power tool operation or when blowing dust. If operation is dusty, also wear a dust mask.

## GENERAL MAINTENANCE

Avoid using solvents when cleaning plastic parts. Most plastics are susceptible to damage from various types of commercial solvents and may be damaged by their use. Use clean cloths to remove dirt, dust, oil, grease, etc.

### **⚠ WARNING:**

Do not at any time let brake fluids, gasoline, petroleum-based products, penetrating oils, etc., come in contact with plastic parts. Chemicals can damage, weaken or destroy plastic which may result in serious personal injury.

# MAINTENANCE

Electric tools used on fiberglass material, wallboard, spackling compounds, or plaster are subject to accelerated wear and possible premature failure because the fiberglass chips and grindings are highly abrasive to bearings, brushes, commutators, etc. Consequently, we do not recommend using this tool for extended work on these types of materials. However, if you do work with any of these materials, it is extremely important to clean the tool using compressed air.

## LUBRICATION

All of the bearings in this tool are lubricated with a sufficient amount of high grade lubricant for the life of the unit under normal operating conditions. Therefore, no further lubrication is required.

## REMOVING THE CHUCK

See Figures 12 - 14.

- Unplug the hammer drill.

### **⚠ WARNING:**

Failure to unplug the tool could result in accidental starting causing possible serious injury.

- Open the chuck jaws by turning the chuck collar counterclockwise.
- Insert a 5/16 in. or larger hex key into the chuck.
- Tighten the chuck jaws using the chuck key provided.
- Loosen the chuck screw by tapping the hex key sharply with a mallet in a clockwise direction.
- Open the chuck jaws and remove the hex key.
- Remove the chuck screw by turning it in a clockwise direction with a screwdriver.

**NOTE:** The screw has left hand threads.

- Reinsert the hex key into the chuck.
- Tighten chuck jaws securely using chuck key provided.
- Loosen the chuck by tapping the hex key sharply with a mallet in a counterclockwise direction.
- Unscrew the chuck by hand.

## TIGHTENING A LOOSE CHUCK

See Figures 12 - 13.

The chuck may become loose on the spindle and begin to shake when using the drill. Also, the chuck screw may become loose, causing the chuck jaws to bind and prevent them from closing. To tighten the chuck:

- Unplug the hammer drill.
- Open the chuck jaws by turning the chuck collar counterclockwise.
- Insert a 5/16 in. or larger hex key into the chuck.
- Tighten the chuck jaws using the chuck key provided.

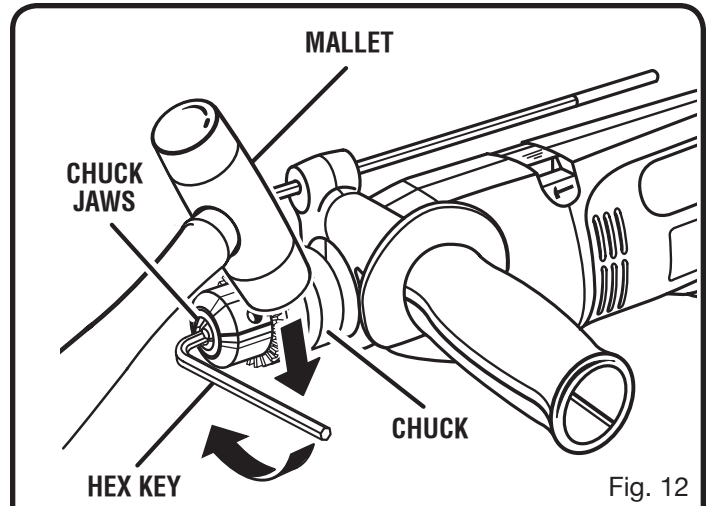

Fig. 12

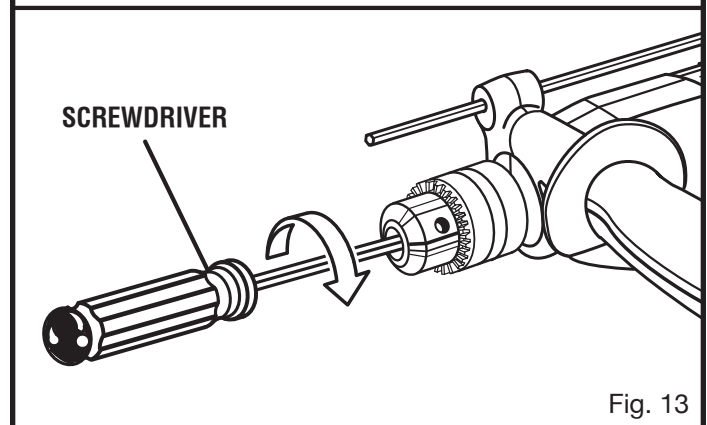

Fig. 13

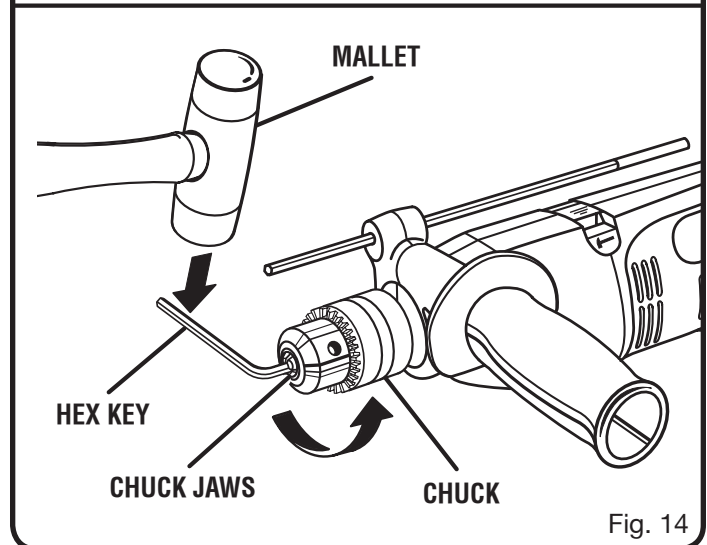

Fig. 14

- Tap the hex key sharply with a mallet in a clockwise direction to tighten the chuck on the spindle.
- Open the chuck jaws and remove the hex key.
- Tighten the chuck screw by turning it in a counterclockwise direction with a screwdriver.

**NOTE:** The screw has left hand threads.





## Free Manuals Download Website

<http://myh66.com>

<http://usermanuals.us>

<http://www.somanuals.com>

<http://www.4manuals.cc>

<http://www.manual-lib.com>

<http://www.404manual.com>

<http://www.luxmanual.com>

<http://aubethermostatmanual.com>

Golf course search by state

<http://golfingnear.com>

Email search by domain

<http://emailbydomain.com>

Auto manuals search

<http://auto.somanuals.com>

TV manuals search

<http://tv.somanuals.com>