



OPERATOR'S MANUAL

GASOLINE PRESSURE WASHER

3000 PSI

RY80030A

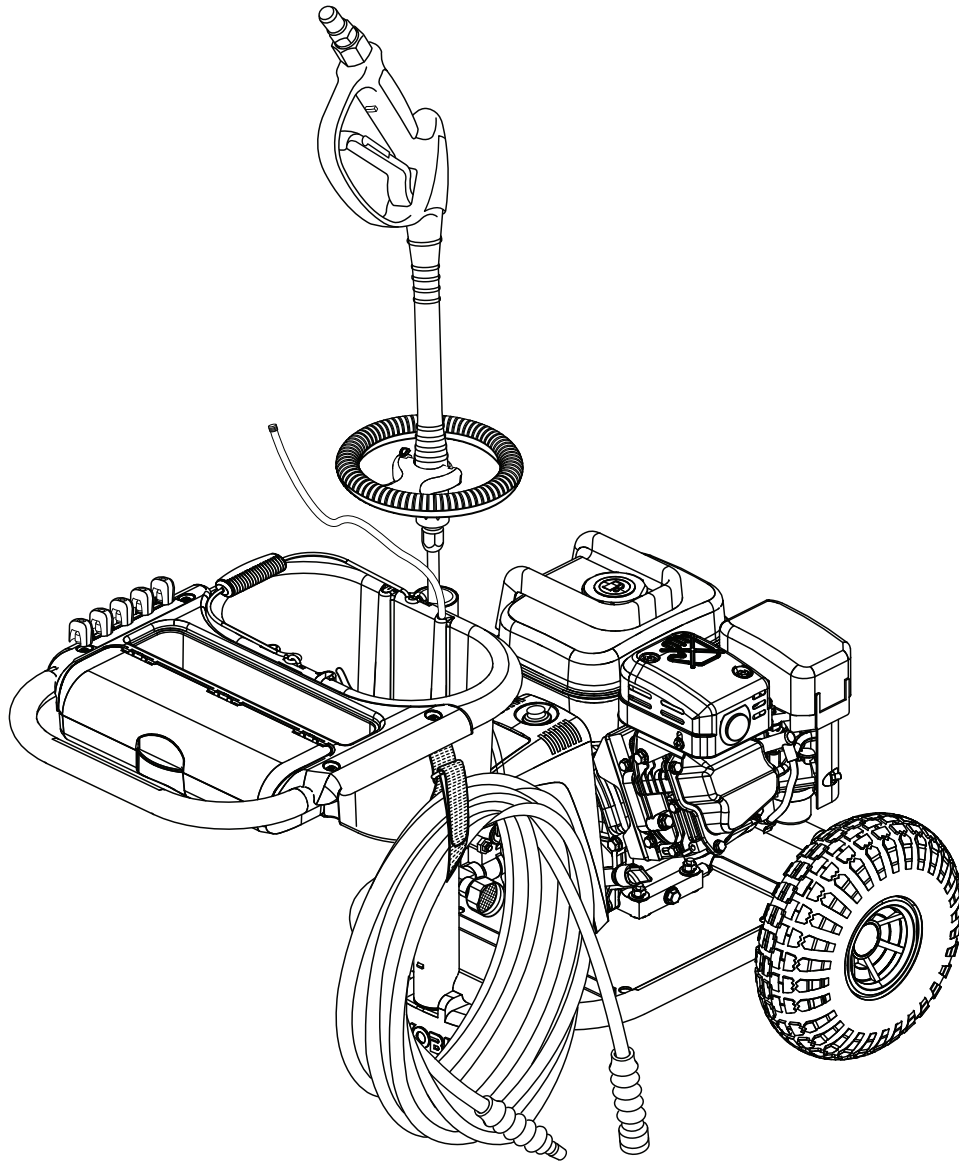

Your pressure washer has been engineered and manufactured to Ryobi's high standard for dependability, ease of operation, and operator safety. When properly cared for, it will give you years of rugged, trouble-free performance.

⚠ DANGER: You WILL be KILLED or SERIOUSLY HURT if you do not follow the instructions in this operator's manual.

Thank you for your purchase.

SAVE THIS MANUAL FOR FUTURE REFERENCE

TABLE OF CONTENTS

■ Introduction	2
■ Important Safety Instructions	3
■ Specific Safety Rules.....	4
■ Symbols.....	5-6
■ Features.....	7-8
■ Assembly	9-12
■ Operation.....	12-15
■ Maintenance.....	16-18
■ Troubleshooting.....	19
■ Warranty	21-25
■ Parts Ordering / Service	26

INTRODUCTION

This tool has many features for making its use more pleasant and enjoyable. Safety, performance, and dependability have been given top priority in the design of this product making it easy to maintain and operate.

IMPORTANT INFORMATION ON THE ENGINE WARRANTY OF THIS PRODUCT can be obtained by contacting:

Robin America, Inc. (a division of Fuji Heavy Industries, Ltd.)
Wood Dale, Illinois
1-630-350-8200
www.robinsubaru.com

IMPORTANT SAFETY INSTRUCTIONS

WARNING:

Read and understand all instructions. Failure to follow all instructions listed below may result in electric shock, fire and/or carbon monoxide poisoning which will cause death or serious personal injury.

READ ALL INSTRUCTIONS BEFORE USING THIS PRODUCT











- **Know your tool.** Read the operator's manual carefully. Learn the machine's applications and limitations as well as the specific potential hazards related to this tool.
- **Keep guards in place** and in working order. Never operate the tool with any guard or cover removed. Make sure all guards are operating properly before each use.
- **Remove adjusting keys and wrenches.** Form habit of checking to see that keys and adjusting wrenches are removed from tool before turning it on.
- **To reduce the risk of injury,** keep children and visitors away. All visitors should wear safety glasses and be kept a safe distance from work area.
- **Keep the area of operation clear of all persons,** particularly small children, and pets.
- **Do not operate the engine in a confined space** where dangerous carbon monoxide fumes can collect. Carbon monoxide, a colorless, odorless, and extremely dangerous gas, can cause unconsciousness or death.
- **Use right tool.** Don't force tool or attachment to do a job it was not designed for. Don't use it for a purpose not intended.
- **Dress properly.** Do not wear loose clothing, gloves, neckties, or jewelry. They can get caught and draw you into moving parts. Rubber gloves and nonskid footwear are recommended when working outdoors. Also wear protective hair covering to contain long hair.
- **Do not operate the equipment while barefoot or when wearing sandals or similar lightweight footwear.** Wear protective footwear that will protect your feet and improve your footing on slippery surfaces.
- **Exercise caution to avoid slipping or falling.**
- **Always wear safety glasses with side shields.** Everyday eyeglasses have only impact-resistant lenses; they are **NOT** safety glasses.
- **Don't overreach or stand on unstable support.** Keep proper footing and balance at all times.
- **Use only recommended accessories.** the use of improper accessories may cause risk of injury.
- **Never stand on tool.** Serious injury could occur if the tool is tipped.
- **Check damaged parts.** Before further use of the tool, a guard or other part that is damaged should be carefully checked to determine that it will operate properly and perform its intended function. Check for alignment of moving parts, binding of moving parts, breakage of parts, mounting, and any other conditions that may affect its operation. A guard or other part that is damaged must be properly repaired or replaced by an authorized service center to avoid risk of personal injury.
- **Never leave tool running unattended. turn power off.** Don't leave tool until it comes to a complete stop.
- **Keep the engine free of grass, leaves, or grease** to reduce the chance of a fire hazard.
- **Keep the exhaust pipe free of foreign objects.**
- **Follow manufacturer's recommendations for safe loading, unloading, transport, and storage of machine.**
- **Be thoroughly familiar with controls.** Know how to stop the product and bleed pressure quickly.
- **Keep tool dry, clean, and free from oil and grease.** Always use a clean cloth when cleaning. Never use brake fluids, gasoline, petroleum-based products, or any solvents to clean tool.
- **Stay alert and exercise control.** Watch what you are doing and use common sense. Do not operate tool when you are tired. Do not rush.
- **Do not operate the product while under the influence of drugs, alcohol, or any medication.**
- **Check the work area before each use.** Remove all objects such as rocks, broken glass, nails, wire, or string which can be thrown or become entangled in the machine.
- **Do not use tool if switch does not turn it on and off.** Have defective switches replaced by an authorized service center.
- **Before cleaning, repairing, or inspecting,** shut off the engine and make certain all moving parts have stopped. Disconnect the spark plug wire, and keep the wire away from the plug to prevent accidental starting.
- **Avoid dangerous environment.** Don't use in damp or wet locations or expose to rain. Keep work area well lit.
- **Never use in an explosive atmosphere.** Normal sparking of the motor could ignite fumes.
- **Do not operate while smoking or near an open flame.**
- **Do not operate around dry brush, twigs, cloth rags, or other flammable materials.**
- **WARNING: Risk of injection or injury** – Do not direct discharge stream at persons.

SPECIFIC SAFETY RULES

- **Never direct a water stream towards people or pets, or any electrical device.**
- **Before starting any cleaning operation,** close doors and windows. Clear the area to be cleaned of debris, toys, outdoor furniture, or other objects that could create a hazard.
- **Never pick up or carry a machine while the engine is running.**
- **Never start the machine** if ice has formed in any part of the equipment.
- **Do not use acids, alkalines, solvents, flammable material, bleaches, or industrial grade solutions** in this product. These products can cause physical injuries to the operator and irreversible damage to the machine.
- **Always operate the machine** on a level surface. If the engine is at an incline, it could seize due to improper lubrication (even at the maximum oil level).
- **WARNING: High pressure jets can be dangerous if subject to misuse.** The jet must not be directed at persons, animals, electrical devices, or the machine itself.
- **Never attempt to make any adjustments while the engine (motor) is running** (except where specifically recommended by the manufacturer).
- **Protective covers must always cover rotating parts when the engine is running.**
- **Keep cooling air intake** (recoil starter area) and muffler side of the engine at least 3 feet away from buildings, obstructions, and other burnable objects.
- **Keep the engine away from flammables and other hazardous materials.**
- **Keep away from hot parts.** The muffler and other engine parts become very hot; use caution.
- **Do not touch the spark plug and ignition cable** when starting and operating the engine.
- **Check fuel hoses and joints** for looseness and fuel leakage before each use.
- **Check bolts and nuts** for looseness before each use. A loose bolt or nut may cause serious engine problems.
- **Always refuel outdoors.** Never refuel indoors or in a poorly ventilated area.
- **Never store the machine with fuel in the fuel tank inside a building** where ignition sources are present, such as hot water and space heaters, clothes dryers, and the like.
- **If the fuel tank has to be drained, do this outdoors.**
- **To reduce the risk of fire and burn injury,** handle fuel with care. It is highly flammable.
- **Do not smoke while handling fuel.**
- **Add fuel before starting the engine.** Never remove the cap of the fuel tank or add fuel while the engine is running or when the engine is hot.
- **Loosen fuel cap slowly** to release pressure and to keep fuel from escaping around the cap.
- **Replace all fuel tank and container caps securely.**
- **Wipe spilled fuel from the unit.** Move 30 feet away from refueling site before starting engine.
- **If fuel is spilled,** do not attempt to start the engine but move the machine away from the area of spillage and avoid creating any source of ignition until fuel vapors have dissipated.
- **Never attempt to burn off spilled fuel under any circumstances.**
- **Before storing, allow the engine to cool.**
- **Store fuel in a cool, well-ventilated area,** safely away from spark and/or flame-producing equipment.
- **Store fuel in containers** specifically designed for this purpose.
- **Empty fuel tank and restrain the unit from moving** before transporting in a vehicle.
- **When servicing use only identical replacement parts.** Use of any other parts may create a hazard or cause product damage.
- **Use cold water only.**
- **Make sure minimum clearance** of 3 feet is maintained from combustible materials.
- **Save these instructions.** Refer to them frequently and use them to instruct other users. If you loan someone this tool, loan them these instructions also.



SYMBOLS

Some of the following symbols may be used on this tool. Please study them and learn their meaning. Proper interpretation of these symbols will allow you to operate the tool better and safer.

SYMBOL	NAME	DESIGNATION/EXPLANATION
	Wet Conditions Alert	Do not expose to rain or use in damp locations.
	Read The Operator's Manual	To reduce the risk of injury, user must read and understand operator's manual before using this product.
	Eye Protection	Always wear safety goggles or safety glasses with side shields and a full face shield when operating this product.
	Safety Alert	Precautions that involve your safety.
	Hot Surface	To reduce the risk of injury or damage, avoid contact with any hot surface.
	Gasoline and Oil	Use unleaded gasoline intended for motor vehicle use with an octane rating of 87 [(R + M)/2] or higher. This product is powered by a 4-cycle engine.
	Risk of Explosion	Fuel and its vapors are explosive and can cause severe burns or death.
	Risk of Fire	Fuel and its vapors are extremely flammable and explosive. Fire can cause severe burns or death.
	Toxic Fumes	Gas products emit carbon monoxide, an odorless, colorless, poison gas. Breathing carbon monoxide can cause nausea, fainting, or death.
	Kickback	To reduce the risk of injury from kickback, hold the spray wand securely with both hands when the machine is on.
	Electric Shock	Failure to use in dry conditions and to observe safe practices can result in electric shock.

SYMBOLS

The following signal words and meanings are intended to explain the levels of risk associated with this product.

SYMBOL	SIGNAL	MEANING
	DANGER:	Indicates an imminently hazardous situation, which, if not avoided, will result in death or serious injury.
	WARNING:	Indicates a potentially hazardous situation, which, if not avoided, could result in death or serious injury.
	CAUTION:	Indicates a potentially hazardous situation, which, if not avoided, may result in minor or moderate injury.
	CAUTION:	(Without Safety Alert Symbol) Indicates a situation that may result in property damage.

SERVICE

Servicing requires extreme care and knowledge and should be performed only by a qualified service technician. For service we suggest you return the product to your nearest **AUTHORIZED SERVICE CENTER** for repair. When servicing, use only identical replacement parts.



WARNING:

To avoid serious personal injury, do not attempt to use this product until you read thoroughly and understand completely the operator's manual. Save this operator's manual and review frequently for continuing safe operation and instructing others who may use this product.



WARNING:



The operation of any power tool can result in foreign objects being thrown into your eyes, which can result in severe eye damage. Before beginning power tool operation, always wear safety goggles or safety glasses with side shields and a full face shield when needed. We recommend Wide Vision Safety Mask for use over eye glasses or standard safety glasses with side shields. Always use eye protection which is marked to comply with ANSI Z87.1.

SAVE THESE INSTRUCTIONS

FEATURES

PRODUCT SPECIFICATIONS

Engine Size.....	211 cc
Engine Output, Horsepower.....	7 HP
Fuel Tank Capacity.....	3.8 quarts (3.6 liters)
Maximum Pounds per Square Inch Pressure.....	3000 psi
Maximum Gallons Per Minute.....	2.7 GPM

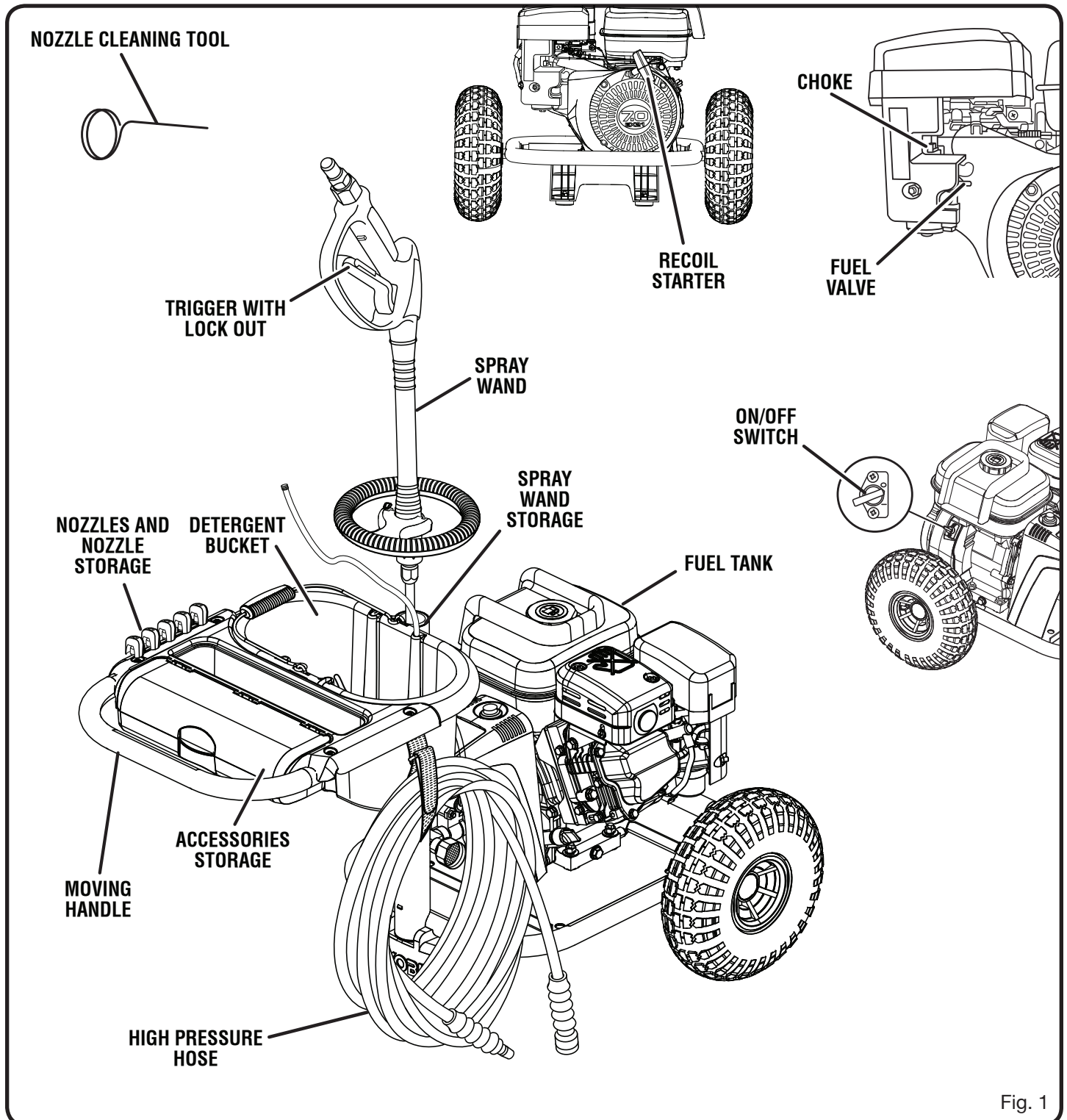

Fig. 1

FEATURES

KNOW YOUR PRESSURE WASHER

See Figure 1.

Before attempting to use this product, familiarize yourself with all operating features and safety rules.

ACCESSORIES STORAGE

Safely stores accessories (not included) within easy reach.

CHOKER

Using the choke makes starting the engine easier. Close the choke for starting a cold engine. The choke lever needs to be half opened or fully opened when starting a warm engine.

DETERGENT BUCKET

The removable detergent bucket holds up to two gallons of detergent. Position the injection hose in the slot closest to the spray wand storage.

FUEL VALVE

The fuel valve must be open to start the engine and should always be closed before storing the machine.

FUEL TANK

This fuel tank has a maximum capacity of 3.8 quarts (3.6 liters). Use unleaded automotive gasoline in the engine.

ON/OFF SWITCH

Located on the side of the motor, the motor won't start until the switch is in the **ON (I)** position.

RECOIL STARTER

The recoil starter is used (along with the **ON/OFF** switch) to start the pressure washer.

SPRAY WAND

The spray wand has a round assist handle that provides added control of the spray wand and helps reduce fatigue.

STORAGE BRACKET

Once the high pressure hose is rolled, hang it on the side of the product using the hook and loop strap for convenient storage.

SUBARU® ENGINE

This 7 HP engine enables the pressure washer to achieve 3,000 PSI and 2.7 gallons per minute.

THERMAL RELIEF VALVE

This pump feature will prevent water temperatures from reaching harmful levels by releasing a small amount of water from a rubber hose. Once the water has drained, the thermal relief valve will reset itself.

TRIGGER WITH LOCK OUT

Pulling the trigger releases a stream of water for high pressure cleaning. The lock out provides protection against unauthorized use.

ASSEMBLY

UNPACKING

This product requires assembly.

- Carefully cut the box down the sides then remove the tool and any accessories from the box. Make sure that all items listed in the packing list are included.

NOTE: This tool is heavy. To avoid back injury, lift with your legs, not your back, and get help when needed.

- Remove and discard the clear cap securing the operator's manual bag to the pump breather tube.
- Inspect the tool carefully to make sure no breakage or damage occurred during shipping.
- Do not discard the packing material until you have carefully inspected and satisfactorily operated the tool.
- If any parts are damaged or missing, please call 1-800-860-4050 for assistance.

PACKING LIST

Pressure Washer
30 ft. High Pressure Hose
Spray Wand Assembly (upper)
Assist Handle Assembly
Spray Wand Extension (lower)
Quick-Connect Nozzle (5)
Nozzle Cleaning Tool
Resting Foot
Axle Assembly (2)
Wheel (2)
Washer (2)
Hardware Bag
4-Cycle Engine Oil (10W-30)
Operator's Manual

WARNING:

If any parts are damaged or missing do not operate this tool until the missing parts are replaced. Failure to heed this warning could result in possible serious personal injury.

WARNING:

Do not attempt to modify this tool or create accessories not recommended for use with this tool. Any such alteration or modification is misuse and could result in a hazardous condition leading to possible serious personal injury.

WARNING:

To prevent accidental starting that could cause serious personal injury, always disconnect the engine spark plug wire from the spark plug when assembling parts.

NOTE: Do not start the pressure washer until the engine has been filled with oil and all hoses are connected. Running this machine without oil will damage the engine while running it without water will damage the high pressure pump.

ATTACHING THE WHEEL ASSEMBLY

See Figure 2.

To attach the wheels to the pressure washer base:

- Locate the axle assembly; remove the hitch pin from the axle.
- Slip the axle into the wheel hole and slide the washer onto the axle.
- Lift the machine and slide the axle/wheel/washer combination into the wheel mounting hole in the machine base as shown.
- Push the hitch pin into the hole on the end of the axle to secure the wheel assembly.

NOTE: The hitch pin should be pushed into the axle until the center of the pin rests on top of the axle.

- Repeat with the second wheel assembly.

NOTE: It is important to always maintain proper air pressure in both wheels.

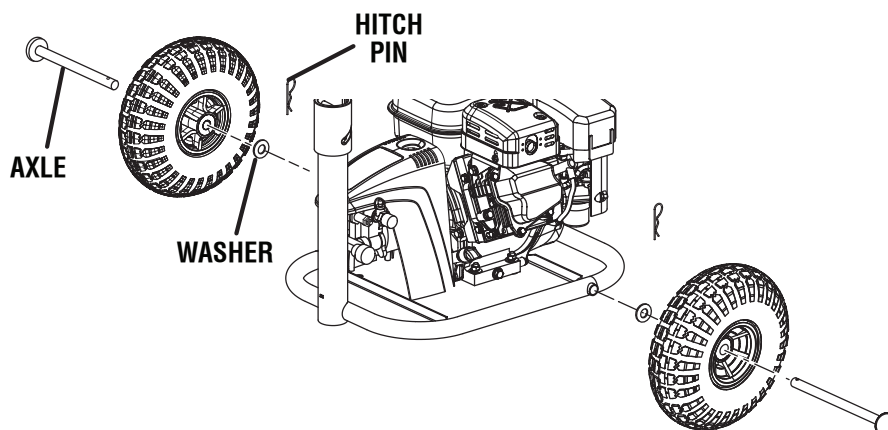

Fig. 2

ASSEMBLY

ATTACHING THE RESTING FOOT

See Figure 3.

- Lift the machine slightly. Slide the resting foot into the bottom of the spray wand storage tube.
- Push the resting foot into the storage tube until the base of the machine rests in the grooves on top of the resting foot.

ASSEMBLING THE SPRAY WAND

See Figure 4.

To attach the assist handle assembly:

- Remove the wing screw from the assist handle assembly then slide the spray wand assembly onto the assist handle assembly bracket.

NOTE: The smooth side of the assist handle assembly can be facing down or up.

- Position the assist handle between the ribs of the spray wand aligning the tab and the detent.
- Secure the assist handle in place by tightening the wing screw.

To attach the spray wand extension:

- Place the threaded end of the wand extension in the connector on the end of the spray wand assembly. Push until it snaps into place.
- Turn the connector clockwise until it stops. This secures the wand extension in place.
- When not in use, place the assembled spray wand into the spray wand storage.

CONNECTING HIGH PRESSURE HOSE TO SPRAY WAND ASSEMBLY

See Figure 5.

- Uncoil the high pressure hose.
- Pull back and hold the quick-connect collar on the high pressure hose.
- Insert the inlet coupler on the spray wand handle into the collar.
- Release the collar and push until it clicks.
- Pull on the hose to be certain it is properly secured.

ATTACHING INJECTION HOSE

See Figure 6.

Before detergent can be used with this machine, the injection hose must be attached.

- Uncoil the clear injection hose.
- Push the open end of the injection hose securely over the barbed fitting.
- Lift the chemical bucket and push the injection hose into the slot on the back of the bucket.
- Replace the bucket in the bucket holder.

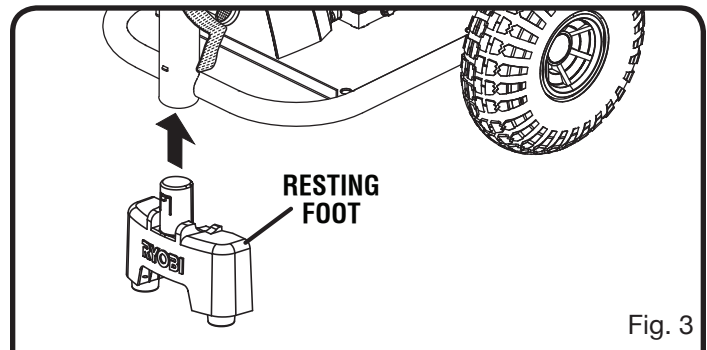

Fig. 3

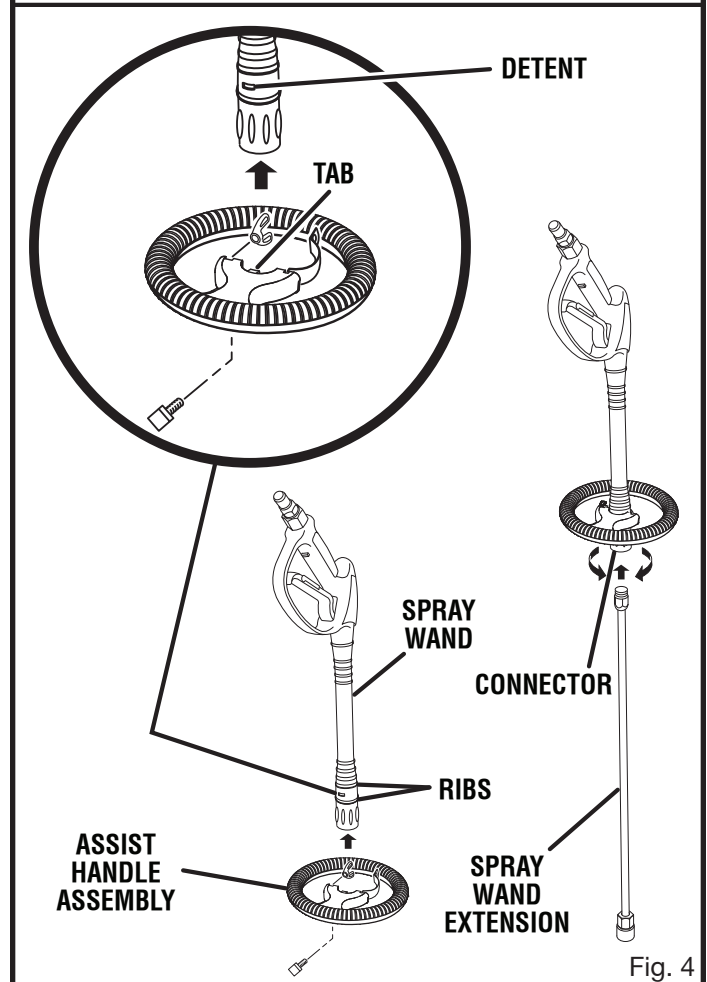

Fig. 4

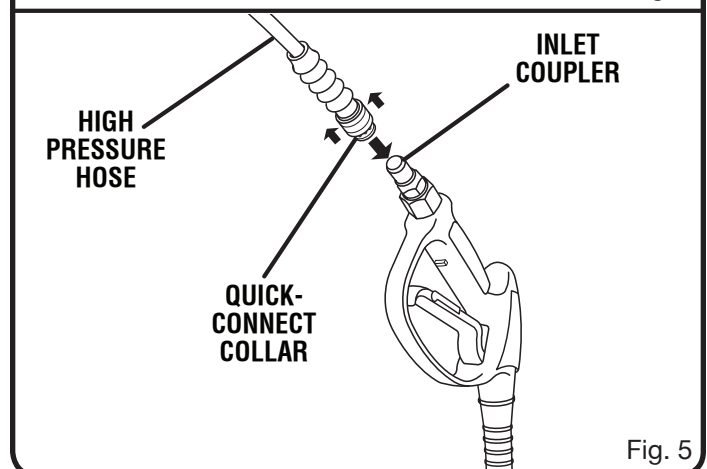

Fig. 5

ASSEMBLY

ADDING OIL TO THE ENGINE

See Figure 7.

NOTE: This machine has been shipped with approximately 2 oz. of oil in the engine from testing. **You must add oil to the engine before starting it the first time.**

CAUTION:

Any attempt to start the engine without adding oil will result in engine failure.

- Place pressure washer on a flat, level surface.
- Unscrew the oil cap/dipstick by turning counter-clockwise.
NOTE: There are two oil cap/dipsticks on each side of the engine.
- Using 4-stroke engine oil (10W-30), fill to the upper level of the oil filter neck (18 oz., 4-cycle engine oil provided).
- Replace the oil cap/dipstick and securely tighten.

NOTE: This engine has a total oil capacity of 20 oz. (.6 liters).

ADDING GASOLINE TO THE FUEL TANK

See Figure 8.

WARNING:

Gasoline and its vapors are highly flammable and explosive. To prevent serious personal injury and property damage, handle gasoline with care. Keep away from ignition sources, handle outdoors only, do not smoke while adding fuel, and wipe up spills immediately.

When adding gas to the pressure washer, make sure the unit is sitting on a flat, level surface and that the engine is not hot. If the engine is hot, let the pressure washer cool before adding gas. **ALWAYS** fill the fuel tank outdoors.

- Make sure the **ON/OFF** switch is in the **OFF (O)** position.
- Close the fuel valve.
- Before removing the fuel cap, clean the area around it. Remove the fuel cap.
- Insert a clean funnel into the fuel tank.
- Slowly pour gasoline into the fuel tank (always use the fuel filter screen when filling the fuel tank). Wipe any spilled fuel off the machine before starting.

NOTE: Do not fill above the top of the fuel filter screen or the gas may overflow when it heats up later and expands.

- Replace fuel cap and securely tighten.
- Clean up any spills before starting the engine.

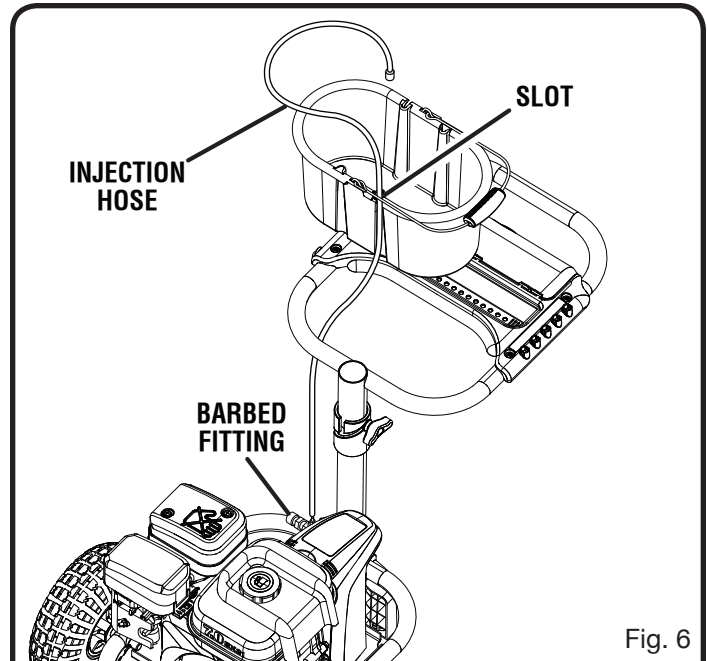

Fig. 6

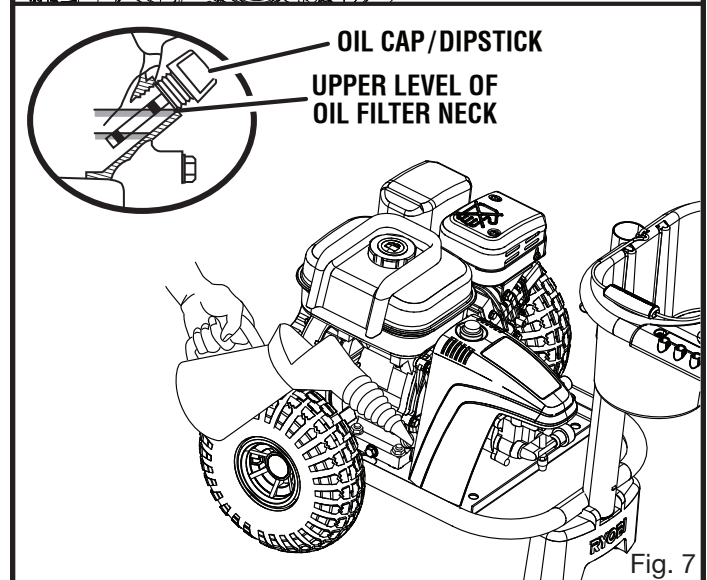

Fig. 7

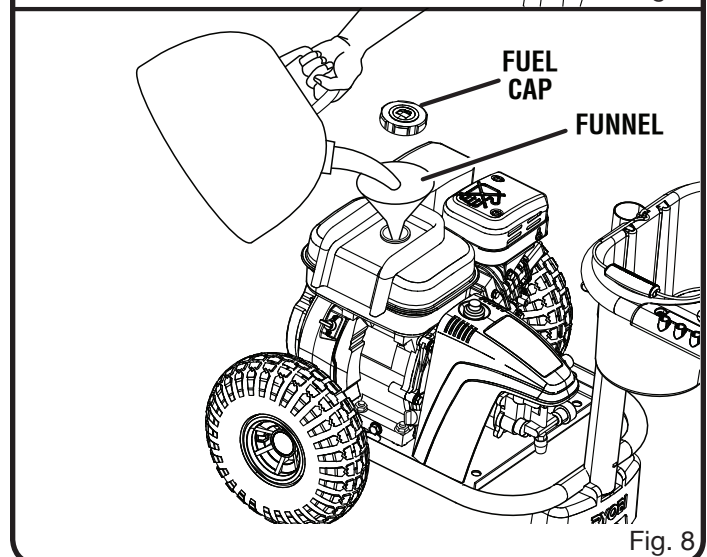

Fig. 8

ASSEMBLY

CONNECTING THE HIGH PRESSURE HOSE TO THE PUMP

See Figure 9.

After the high pressure hose has been uncoiled and attached to the spray wand:

- Pull back and hold the quick-connect collar on the pump.
- Insert the nozzle on the end of the quick-connect high pressure hose into the collar.
- Release the collar.
- Pull on the hose to be certain it is properly secured.

CONNECTING THE GARDEN HOSE TO THE PRESSURE WASHER

See Figure 10.

Water supply must come from a home water main. NEVER use hot water or water from pools, lakes, etc. Before connecting the garden hose to the pressure washer:

- Run water through the hose for 30 seconds to clean any debris from the hose.
- Inspect the screen in the water intake.
- If the screen is damaged, do not use the machine until the screen has been replaced.
- If the screen is dirty, clean it before connecting the garden hose to the machine.

To connect the garden hose to the machine:

- Uncoil the garden hose.

NOTE: There must be a minimum of 10 feet of unrestricted hose between the pressure washer intake and the hose faucet or shut off valve (such as a "Y" shut off connector).

- With the hose faucet turned completely off, attach the end of the garden hose to the water intake. Tighten by hand.

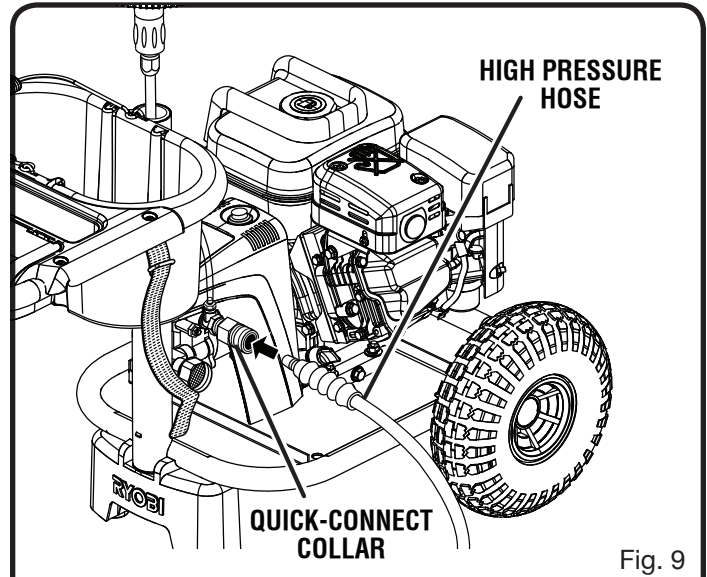

Fig. 9

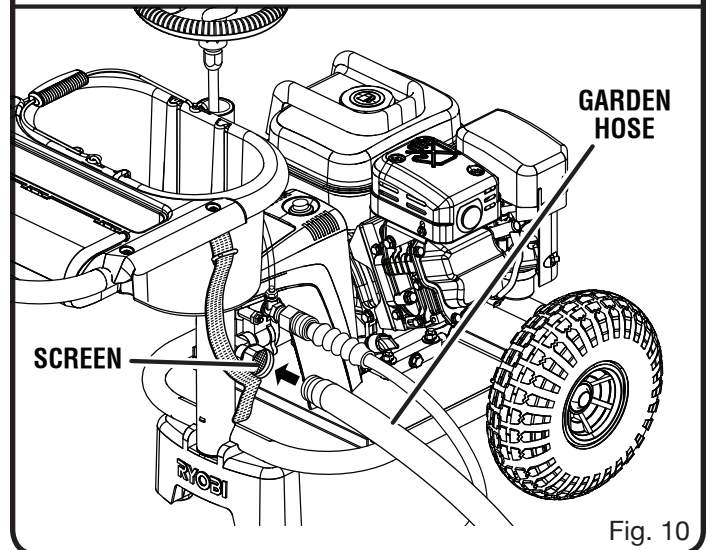

Fig. 10

OPERATION

⚠ WARNING:

Do not allow familiarity with tools to make you careless. Remember that a careless fraction of a second is sufficient to inflict serious injury.

⚠ WARNING:

Always wear safety goggles or safety glasses with side shields when operating tools. Failure to do so could result in objects being thrown into your eyes, resulting in possible serious injury.

⚠ WARNING:

Do not use any attachments or accessories not recommended by the manufacturer of this tool. The use of attachments or accessories not recommended can result in serious personal injury.

⚠ WARNING:

Do not direct discharge stream at persons. Failure to heed this warning could result in serious injury.

OPERATION

APPLICATIONS

This product has been designed for the purposes listed below:

- Removing dirt and mold from decks, cement patios, and house siding
- Cleaning cars, boats, motorcycles, outdoor furniture, and grills

STARTING/STOPPING THE PRESSURE WASHER

See Figures 11 - 13.

CAUTION:

Do not run the pump without the water supply connected and turned on.

Before starting the engine, connect all hoses and check all fluids (oil and gas). Turn the garden hose on then squeeze the trigger. This relieves air pressure caused by turning on the water. Hold the trigger until a steady stream of water appears.

To start an engine that is cold or has run dry:

- Close the fuel valve.
- Fill the fuel tank (if necessary).
- Connect the garden hose to the pump and turn on the water supply.
- Open the fuel valve.
- Place the **ON/OFF** switch in the **ON (I)**.
- Push the choke lever to position **A (CLOSED)**.

NOTE: If the engine is cold, close the choke fully. If the engine is warm, open the choke lever half-way or keep it opened fully.

- Give the recoil starter short, brisk pulls to start the engine.
- If the engine fires, or begins to sputter and/or cough without catching, move the choke lever to the half-way position.

NOTE: Never pull the recoil starter more than four or five times with the choke closed as this causes flooding.

- With the choke in the half-way position, pull the recoil starter again. The engine should now start.

NOTE: If the choke remains in the closed position, the engine will continue to sputter and/or cough but will not start.

- As the engine warms up, move the choke lever slowly to position **B (OPEN)**.
- Return the recoil starter gently to the engine housing. Do not allow the rope to snap back.
- Let the engine warm up a few minutes before using.

To stop the engine using the ON/OFF switch:

- Turn the **ON/OFF** switch to **OFF (O)**.
- Close the fuel valve.

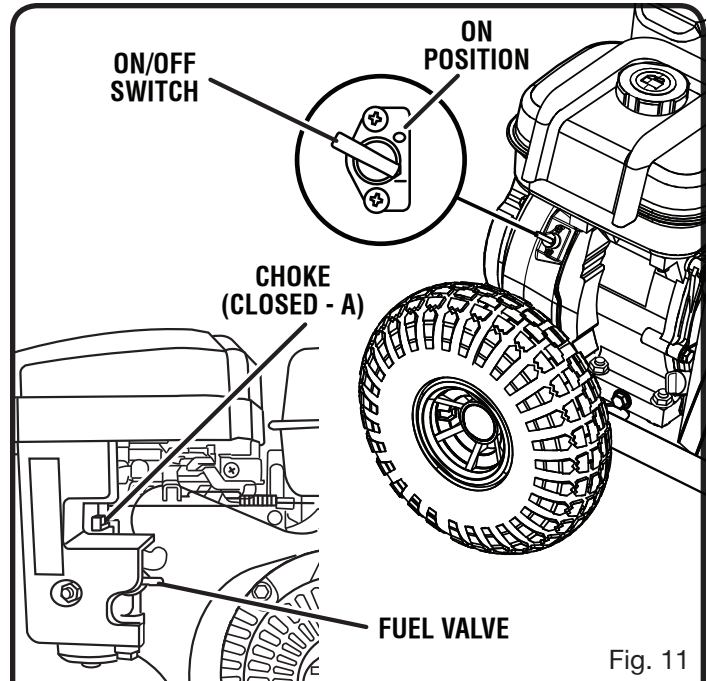

Fig. 11

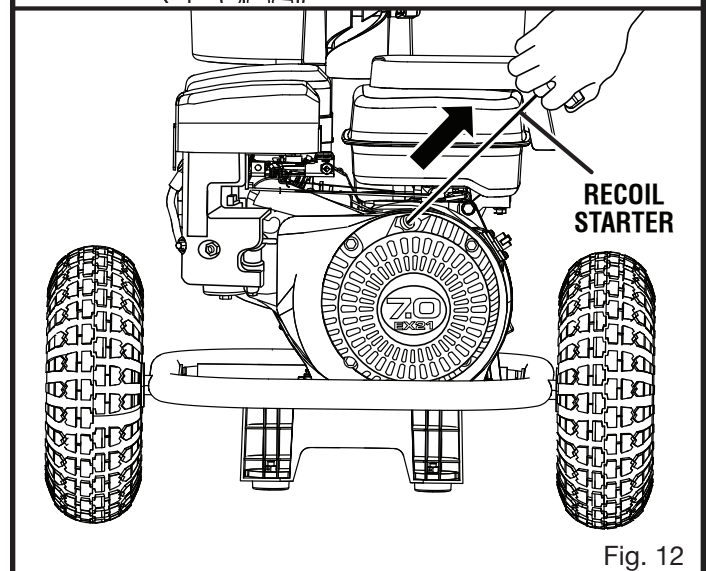

Fig. 12

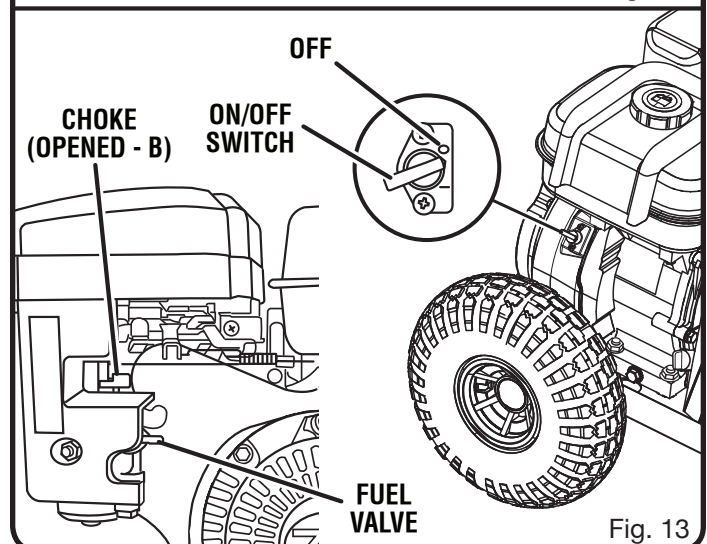

Fig. 13

OPERATION

To stop the engine using the fuel valve:

- Close the fuel valve and wait for the engine to stop.

NOTE: Avoid letting fuel remain in the carburetor for long periods as this can clog carburetor passages with impurities resulting in malfunctions.

SELECTING THE RIGHT QUICK-CONNECT NOZZLE FOR THE JOB

See Figure 14 - 15.

Before starting any cleaning job, determine the best nozzle for the job. Each of the five nozzles has a different spray pattern. The nozzle colors and spray patterns are: black (low pressure), white (medium pressure) 40°, green (medium pressure) 25°, yellow (high pressure) 15°, and red (high pressure) 0°.

NOTE: For a gentle rinse, select the white 40° or green 25° nozzle. Scouring the surface requires a more direct spray of water. Select the yellow 15° or red 0° nozzle for tough jobs. Apply detergent using the black nozzle.

CAUTION:

NEVER change nozzles without locking the lock out on the spray wand.

Using the quick-connect collar, changing nozzles is easy.

- Turn off the pressure washer and shut off the water supply. Pull trigger to release water pressure.

To connect a nozzle to the spray wand:

- Push the nozzle into the quick-connect collar until it clicks in place and is secured properly.

To disconnect a nozzle from the spray wand once the cleaning job is complete:

- Place hand over nozzle then pull back the quick-connect collar. Place nozzle in the nozzle storage area on the top of the machine.

USING THE SPRAY WAND TRIGGER

See Figure 16.

For greater control and safety, keep both hands on the spray wand at all times.

- Pull back and hold the trigger to operate the pressure washer.
- Release the trigger to stop the flow of water through the nozzle.

To engage the lock out:

- Push up on the lock out until it clicks into the slot.

To disengage the lock out:

- Push the lock out down and into its original position.

For the most effective cleaning, the spray nozzle should be between 8 in. and 24 in. from the surface to be cleaned. If the spray is too close it can damage the cleaning surface.

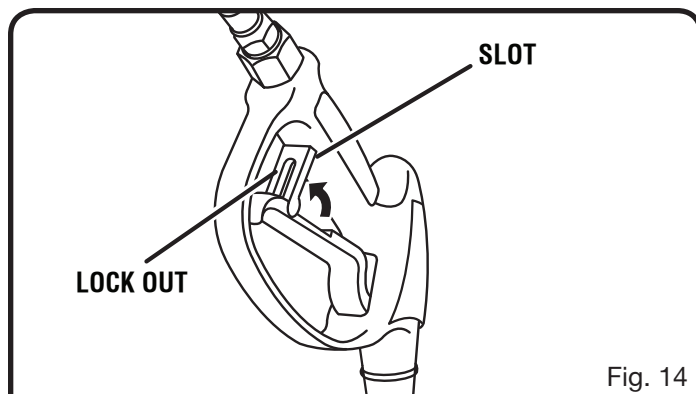

Fig. 14

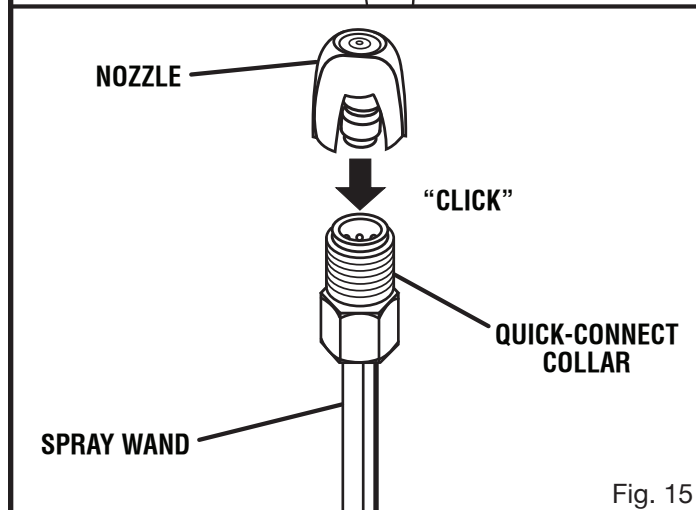

Fig. 15

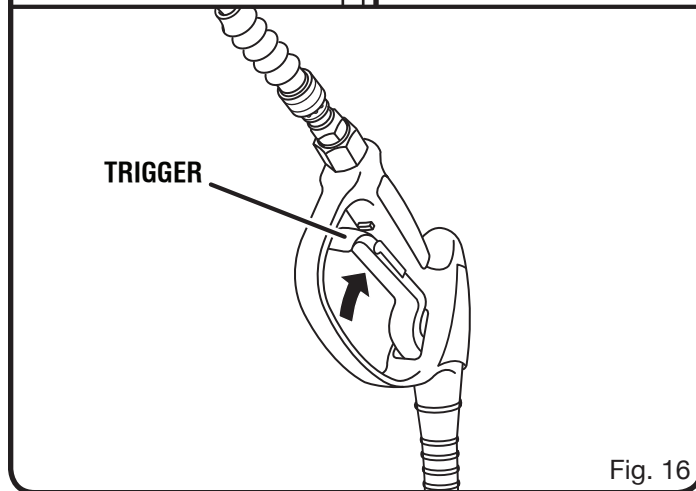

Fig. 16

OPERATION

MOVING THE PRESSURE WASHER

See Figure 17.

- Loosen the pivot knob located halfway down the spray wand storage tube.
- Grasp the handle at the rear of the pressure washer. Turn the top section of the pressure washer until it is fully extended as shown in figure 17. Retighten the pivot knob.
- Grasp the moving handle and lift the machine off the resting foot. Roll the machine to the desired position.

STORING THE PRESSURE WASHER

See Figure 17.

Allow 30 minutes of “cool down” time before placing the storage handle in the “store” position. Store machine in a dry, covered area where the weather can’t damage it.

WASHING WITH DETERGENT

See Figure 18.

Use only detergents designed for pressure washers; household detergents can damage the pump. Many detergents require mixing prior to use. Prepare cleaning solution as instructed on the solution bottle.

- Place the injection hose in the bottom of the detergent bucket.
- Carefully pour the cleaning solution into the bucket taking care not to splash the solution or place the bottle in the bucket.
- Install the black nozzle on the spray wand.
- Spray the detergent on a dry surface using long, even, overlapping strokes. To prevent streaking, do not allow the detergent to dry on the surface.

Before shutting off the engine:

- Place the injection hose in a bucket of clean water.
- Flush for 1 - 2 minutes (spray clear water through the spray wand).
- Shut off the engine.

NOTE: Shutting **OFF (O)** the engine will not relieve pressure in the system. Pull trigger to release water pressure.

RINSING WITH THE PRESSURE WASHER

- Turn off the pressure washer and shut off the water supply. Pull trigger to release water pressure.
- Engage the lock out on the wand by pushing up on the lock out until it clicks into the slot.
- Pull back and hold the collar.
- Remove the nozzle by pulling it from the collar.
- Select the right nozzle for the job:
 - Use lower pressure nozzle (white or green) to wash items such as a car or boat.
 - Use higher pressure nozzle (yellow or red) for jobs such as stripping paint and degreasing the driveway. When using these nozzles, test a small area first to avoid surface damage.
- Start at the top of the area to be rinsed and work down, overlapping the strokes.

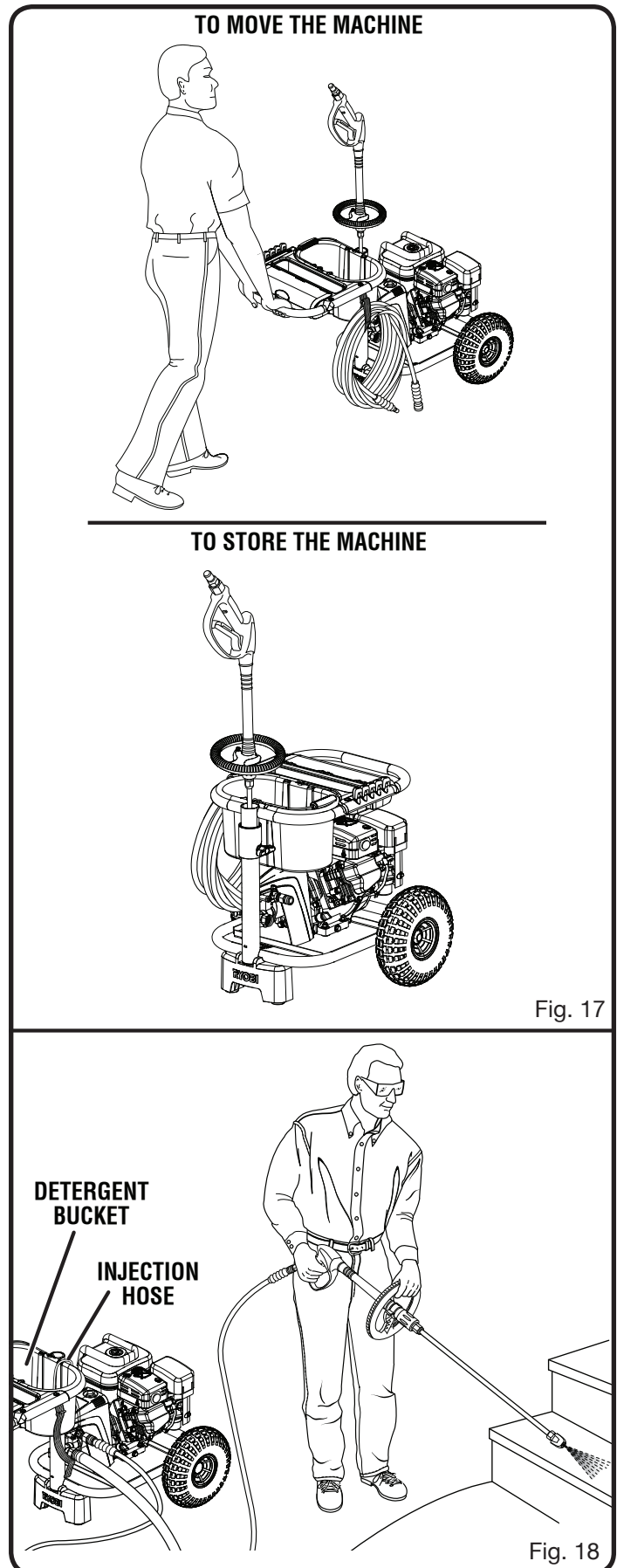

Fig. 17

Fig. 18

MAINTENANCE

WARNING:

When servicing, use only identical replacement parts. Use of any other parts may create a hazard or cause product damage.

WARNING:

Always wear safety goggles or safety glasses with side shields during power tool operation or when blowing dust. If operation is dusty, also wear a dust mask.

WARNING:

Before inspecting, cleaning or servicing the machine, shut off engine, wait for all moving parts to stop, and disconnect spark plug wire and move it away from spark plug. Failure to follow these instructions can result in serious personal injury or property damage.

GENERAL MAINTENANCE

NOTE: Regarding the engine: maintenance, replacement or repair of the emission control devices and systems may be performed by any nonroad engine repair establishment or individual.

Avoid using solvents when cleaning plastic parts. Most plastics are susceptible to damage from various types of commercial solvents and may be damaged by their use. Use clean cloths to remove dirt, dust, oil, grease, etc.

WARNING:

Do not at any time let brake fluids, gasoline, petroleum-based products, penetrating oils, etc., come in contact with plastic parts. Chemicals can damage, weaken or destroy plastic which may result in serious personal injury.

Only the parts shown on the parts list are intended to be repaired or replaced by the customer. All other parts should be replaced at an authorized service center.

Before running the engine, perform the following pre-operation steps:

- Check that all bolts, nuts, etc., are securely tightened.
- Make sure the air filter is clean.
- Check both the engine oil level and the fuel tank level; refill as needed.
- Inspect the work area for hazards.
- If there is excessive noise or vibration, stop the unit immediately.

CLEANING THE AIR FILTER

See Figure 19.

A dirty air filter will cause starting difficulty, loss of performance, and shorten the life span of the engine. Check the air filter monthly. If working in dusty soil, clean the air filter after each refueling. For best performance, replace the air filter at least once a year.

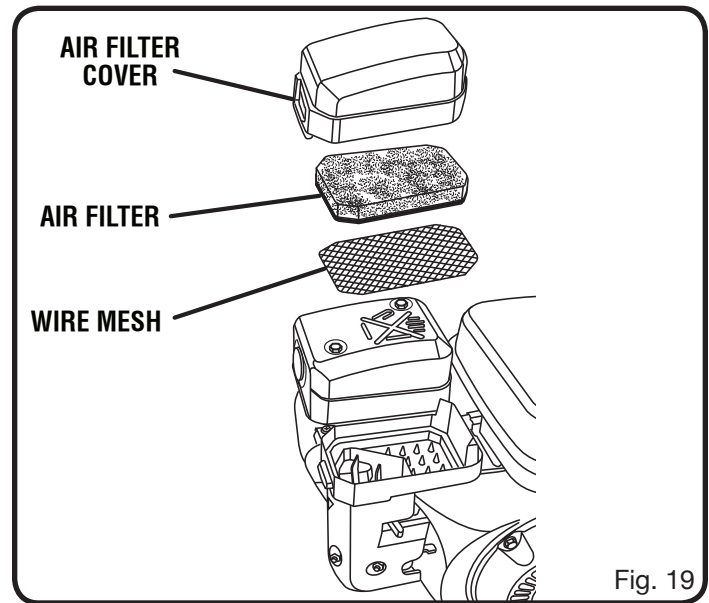

Fig. 19

To clean the air filter:

- Remove the cover.
 - Lift the edge of the air filter carefully and pull it out.
 - Wash the air filter with warm, soapy water.
 - Rinse and squeeze to dry.
 - Put small amount of 30 wt. motor oil on the filter sponge. Squeeze out the excess oil then reinstall the air filter.
- NOTE:** Make sure the filter is seated properly inside the cover. Installing the filter incorrectly will allow dirt to enter the engine, causing rapid engine wear.
- Reinstall the cover.

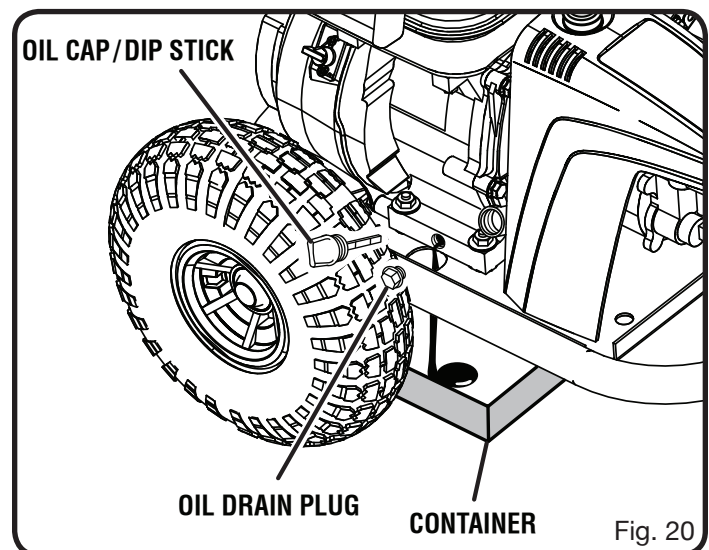

Fig. 20

MAINTENANCE

CHANGING THE OIL

See Figure 20.

- Shut off the engine.
- Place a container under the pressure washer.
- Remove the oil drain plug and drain the old oil.
NOTE: Drain the oil while the engine is still warm but not hot. Warm oil will drain quickly and more completely.
- Replace the oil drain plug.
- Replace the oil with new, clean oil. This engine will hold 20 oz. or .6 liters of oil (10W-30).

NOTE: Consult hazardous waste management guidelines in your area for the proper way to dispose of used fuel.

CHECKING A FOULED SPARK PLUG

See Figure 21.

- Clean carbon deposits off the spark plug electrode using a plug cleaner or wire brush.
- Check electrode gap. The gap should be .6 mm - .7 mm. Adjust the gap, if necessary, by carefully bending the side electrode.
(Recommended spark plug: NGK BR-6HS; CHAMPION RL86C.)

CLEANING FUEL CUP

See Figure 22.

- Inspect fuel cup for water and dirt.
- If dirt or water is present, **CLOSE THE FUEL VALVE** and remove the fuel cup. Using a wrench, grasp the square on the bottom of the fuel cup and turn clockwise.
- After removing dirt and water, wash the fuel cup with kerosene or gasoline. Reinstall securely to prevent leakage.

NOZZLE MAINTENANCE

See Figure 23.

Excessive pump pressure (a pulsing sensation felt while squeezing the trigger) may be the result of a clogged or dirty nozzle.

- Turn off the pressure washer and shut off the water supply. Pull trigger to release water pressure.
- Remove the nozzle from the spray wand.
NOTE: Never point the spray wand at your face.
- Using the nozzle cleaning tool provided, free any foreign materials clogging or restricting the nozzle.
- Using a garden hose, flush debris out of nozzle by back flushing (running the water through the nozzle backwards or from the outside to the inside).
- Reinstall the nozzle then reconnect the nozzle to the spray wand.
- Turn on the water supply and start the engine.

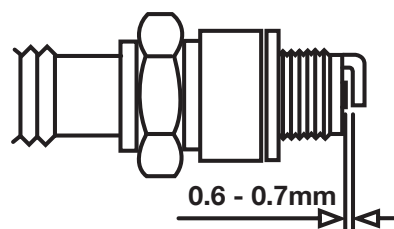

Fig. 21

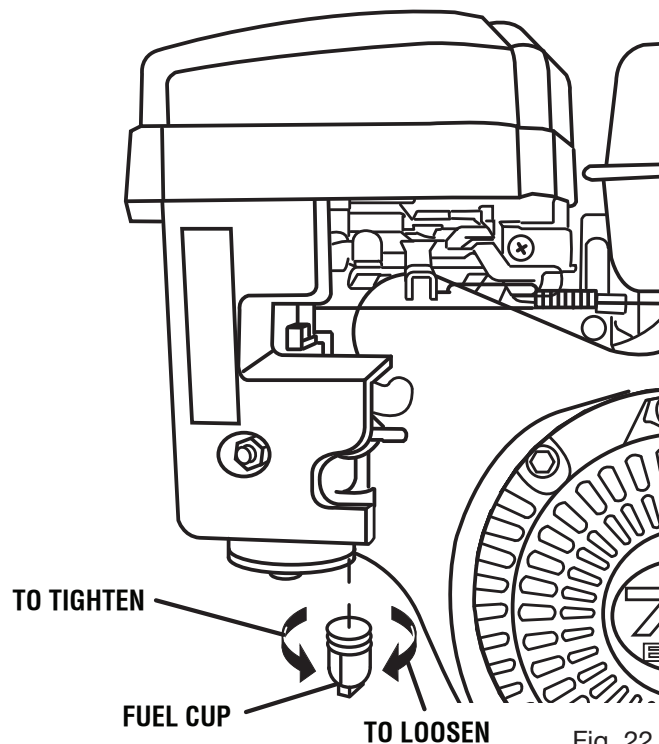

Fig. 22

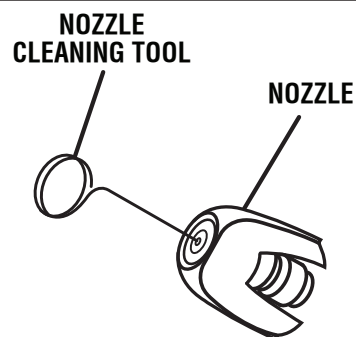

Fig. 23

REPLACING THE FUEL HOSE

Replace the fuel hose every 1,000 hours of use. If fuel leaks from fuel hose, replace the hose immediately.

PUMP MAINTENANCE

We recommend having the pump oil changed every 100 hours to ensure longer life of the machine. This service should be performed by an authorized service center.

MAINTENANCE

STORING THE PRESSURE WASHER

It is important to store this product in a frost-free area. Always empty water from all hoses, the pump, the fuel tank, and the detergent bucket before storing.

NOTE: Use of a fuel stabilizer and pump saver will give you better performance and increase the life of the machine.

Discharge Fuel:

Drain the fuel tank completely. Stored gas can go stale in 30 days.

Remove the drain screw from the carburetor float chamber and discharge fuel.

Engine Oil:

Drain the oil and replace with fresh, clean oil.

Spark Plug:

- Disconnect spark plug wire and remove the spark plug. Pour about a teaspoon of clean, air-cooled, four-cycle oil through the spark plug hole into the combustion chamber.
- Leaving the spark plug out, pull the starter cord two or three times to coat the inside of the cylinder wall.

- Inspect the spark plug and clean or replace, as necessary.
- Reinstall the spark plug, but leave the spark plug wire disconnected.

Air Filter:

- Clean the air filter.

Hoses, Detergent Bucket, and Pump:

Flush the injection hose with clean water for 1 - 2 minutes. Remove all hoses. Empty the pump by pulling on the recoil starter about 6 times. This should remove most of the liquid from the pump.

PREPARING FOR USE AFTER STORAGE

- Pull the recoil starter grip three or four times to clean oil from the combustion chamber.
- Remove spark plug from the cylinder. Wipe oil from the spark plug and return it to the cylinder.
- Reconnect the spark plug wire.
- Refuel the machine as described earlier in the operator's manual.

PERIODIC MAINTENANCE SCHEDULE TABLE

Maintenance Items	Every 8 hrs.	Every 20 hrs.	Every 50 hrs.	Every 200 hrs.	Every 500 hrs.	Every 1,000 hrs.
Clean engine & check bolts & nuts	X					
Check and refill engine oil	X					
Change engine oil*		X	X			
Clean spark plug			X			
Clean air cleaner			X			
Replace air cleaner element				X		
Clean fuel cup				X		
Clean & adjust spark plug & electrodes				X		
Replace spark plug					X	
Remove carbon from cylinder head**					X	
Check & adjust valve clearance**					X	
Clean & adjust carburetor**					X	
Replace fuel lines						X
Overhaul engine if necessary**						X

* Initial oil change should be performed after the first 20 hours of operation. Thereafter, change oil every 50 hours of use. Do not pour old oil down sewage drains, into garden soil, or into open streams. Your local zoning or environmental regulations will give you more detailed instruction on proper disposal.

** Have performed by your nearest service center

TROUBLESHOOTING

PROBLEM	CAUSE	SOLUTION
Engine fails to start	<ol style="list-style-type: none"> 1. Engine switch is in the off position 2. No fuel in tank 3. Spark plug shorted or fouled 4. Spark plug is broken (cracked porcelain or electrodes broken) 5. Ignition lead wire shorted, broken, or disconnected from spark plug 6. Ignition inoperative 	<ol style="list-style-type: none"> 1. Move switch to start. 2. Fill tank. 3. Replace spark plug. 4. Replace spark plug. 5. Replace lead wire or attach to spark plug. 6. Contact authorized service center.
Engine hard to start	<ol style="list-style-type: none"> 1. Water in gasoline 2. Engine is under or over choked 3. Weak spark at spark plug 	<ol style="list-style-type: none"> 1. Drain entire system and refill with fresh fuel. 2. Adjust choke as necessary. 3. Contact authorized service center.
Engine lacks power	<ol style="list-style-type: none"> 1. Dirty air filter 	<ol style="list-style-type: none"> 1. Clean or replace air filter.
Detergent fails to mix with spray	<ol style="list-style-type: none"> 1. Detergent injection hose is not properly submerged 2. High pressure nozzle attached 	<ol style="list-style-type: none"> 1. Insert injection hose into detergent storage bucket. 2. Use low pressure nozzle (black) to apply detergent.
Pump doesn't produce pressure	<ol style="list-style-type: none"> 1. Low pressure nozzle installed 2. Inadequate water supply 3. Spray wand leaks 4. Nozzle is clogged 5. Pump is faulty 	<ol style="list-style-type: none"> 1. Replace with high pressure nozzle. 2. Provide adequate water flow. 3. Replace wand. 4. Clean nozzle. 5. Contact authorized service center.
Machine doesn't reach high pressure	<ol style="list-style-type: none"> 1. Diameter of garden hose is too small 2. Water supply is restricted 3. Not enough inlet water 4. Wrong nozzle is attached 	<ol style="list-style-type: none"> 1. Replace with 3/4 in. garden hose. 2. Check garden hose for kinks, leaks, and blockages. 3. Open water source full force. 4. Attach the high pressure nozzle.

WARRANTY

FEDERAL EMISSIONS COMPONENT DEFECT WARRANTY EMISSIONS COMPONENT DEFECT WARRANTY COVERAGE

This emission warranty is applicable in all States, except the State of California.

Fuji Heavy Industries Ltd. and Robin America Inc., Wood Dale, Illinois, (herein "ROBIN AMERICA") warrant(s) to the initial retail purchaser and each subsequent owner, that this Nonroad engine (herein "engine") has been designed, built, and equipped to conform at the time of initial sale to all applicable regulations of the U.S. Environmental Protection Agency (EPA), and that the engine is free of defects in materials and workmanship which would cause this engine to fail to conform with EPA regulations during its warranty period.

For the components listed under PARTS COVERED, the service dealer authorized by ROBIN AMERICA will, at no cost to you, make the necessary diagnosis, repair, or replacement necessary to ensure that the engine complies with applicable U.S. EPA regulations.

EMISSION COMPONENT DEFECT WARRANTY PERIOD

The warranty period for this engine begins on the date of sale to the initial purchaser and continues for a period of 3 years.

PARTS COVERED

Listed below are the parts covered by the Emission Components Defect Warranty. Some of the parts listed below may require scheduled maintenance and are warranted up to the first scheduled replacement point for that part.

- (1) Fuel Metering System
 - (i) Carburetor and internal parts (and/or pressure regulator or fuel injection system).
 - (ii) Air/fuel ratio feedback and control system, if applicable.
 - (iii) Cold start enrichment system, if applicable.
 - (iv) Regulator assembly (gaseous fuel, if applicable)
- (2) Air Induction System
 - (i) Intake manifold, if applicable
 - (ii) Air filter.
- (3) Ignition System
 - (i) Spark plugs.
 - (ii) Magneto or electronic ignition system.
 - (iii) Spark advance/retard system, if applicable.
- (4) Exhaust manifold, if applicable
- (5) Miscellaneous Items Used in Above Systems.
 - (i) Electronic controls, if applicable
 - (ii) Hoses, belts, connectors, and assemblies.
 - (iii) Filter lock assembly (gaseous fuel, if applicable)

OBTAINING WARRANTY SERVICE

To obtain warranty service, take your engine to the nearest authorized Robin America service dealer. Bring your sales receipts indicating date of purchase for this engine. The service dealer authorized by ROBIN AMERICA will perform the necessary repairs or adjustments within a reasonable amount of time and furnish you with a copy of the repair order. All parts and accessories replaced under this warranty become the property of ROBIN AMERICA.

WHAT IS NOT COVERED*

Conditions resulting from tampering, misuse, improper adjustment (unless they were made by the service dealer authorized by ROBIN AMERICA during a warranty repair), alteration, accident, failure to use the recommended fuel and oil, or not performing required maintenance services.* The replacement parts used for required maintenance services.* Consequential damages such as loss of time, inconvenience, loss of use of the engine or equipment, etc.* Diagnosis and inspection charges that do not result in warranty-eligible service being performed.* Any non-authorized replacement part, or malfunction of authorized parts due to use of non-authorized parts.

OWNER'S WARRANTY RESPONSIBILITIES

As the engine owner, you are responsible for the performance of the required maintenance listed in your owner's manual. ROBIN

AMERICA recommends that you retain all receipts covering maintenance on your engine, but ROBIN AMERICA cannot deny warranty solely for the lack of receipts or for your failure to ensure the performance of all scheduled maintenance.

As the engine owner, you should however be aware that ROBIN AMERICA may deny warranty coverage if your engine or a part has failed due to abuse, neglect, improper maintenance, or unapproved modifications.

You are responsible for presenting your engine to the nearest service dealer authorized by ROBIN AMERICA when a problem exists.

If you have any questions regarding your warranty rights and responsibilities, you should contact the Robin America customer service department at 1-630-350-8200 for the information.

THINGS YOU SHOULD KNOW ABOUT THE EMISSION CONTROL SYSTEM WARRANTY MAINTENANCE AND REPAIRS

You are responsible for the proper maintenance of the engine. You should keep all receipts and maintenance records covering the performance of regular maintenance in the event questions arise. These receipts and maintenance records should be transferred to each subsequent owner of the engine. ROBIN AMERICA reserves the right to deny warranty coverage if the engine has not been properly maintained. Warranty claims will not be denied, however, solely because of the lack of required maintenance or failure to keep maintenance records.

MAINTENANCE, REPLACEMENT, OR REPAIR OF EMISSION CONTROL DEVICES AND SYSTEMS MAY BE PERFORMED BY ANY REPAIR ESTABLISHMENT OR INDIVIDUAL; HOWEVER, WARRANTY REPAIRS MUST BE PERFORMED BY A SERVICE DEALER AUTHORIZED BY ROBIN AMERICA. THE USE OF PARTS THAT ARE NOT EQUIVALENT IN PERFORMANCE AND DURABILITY TO AUTHORIZED PARTS MAY IMPAIR THE EFFECTIVENESS OF THE EMISSION CONTROL SYSTEM AND MAY HAVE A BEARING ON THE OUTCOME OF A WARRANTY CLAIM.

If other than the parts authorized by ROBIN AMERICA are used for maintenance replacements or for the repair of components affecting emission control, you should assure yourself that such parts are warranted by their manufacturer to be equivalent to the parts authorized by ROBIN AMERICA in their performance and durability.

HOW TO MAKE A CLAIM

All repair qualifying under this limited warranty must be performed by a service dealer authorized by ROBIN AMERICA. In the event that any emission-related part is found to be defective during the warranty period, you shall notify Robin America customer service department at 1-630-350-8200 and you will be advised of the appropriate warranty service dealer or service providers where the warranty repair can be performed.

WARRANTY

CALIFORNIA EMISSION CONTROL WARRANTY STATEMENT YOUR WARRANTY RIGHTS AND OBLIGATIONS

The California Air Resources Board and Fuji Heavy Industries Ltd. (herein "FUJI") are pleased to explain the emission control system warranty on your small off-road engine (SORE). In California, new SOREs must be designed, built, and equipped to meet the State's stringent anti-smog standards. FUJI must warrant the emission control system on your SOREs for the periods of time described below, provided there has been no abuse, neglect or improper maintenance of your SOREs.

Your emissions control system may include parts such as the carburetor or fuel-injection system, fuel lines, and the ignition system. Also included may be hoses, clamps, connectors and other associated components.

Where a warrantable condition exists, FUJI will repair your small off-road engine at no cost to you including diagnosis, parts, and labor.

MANUFACTURER'S WARRANTY COVERAGE:

This emissions control system is warranted for two (2) years. If any emission related part on your engine is defective, the part will be repaired or replaced by FUJI.

OWNER'S WARRANTY RESPONSIBILITIES:

- As the SORE owner, you are responsible for the performance of the required maintenance listed in your Owner's Manual. FUJI recommends that you retain all receipts covering maintenance on your SORE, but FUJI cannot deny warranty solely for the lack of receipts.
- As the SORE owner, you should, however, be aware that FUJI may deny you warranty coverage if your SORE or a part has failed due to abuse, neglect, or improper maintenance, or unapproved modifications.
- You are responsible for presenting your SORE to a distribution center or service center authorized by ROBIN AMERICA Inc., 940 Lively Blvd., Wood Dale, IL 60191 (herein ROBIN AMERICA) as soon as a problem exists. The warranty repairs should be completed in a reasonable amount of time, not to exceed 30 days.

If you have a question regarding your warranty coverage, you should contact the Robin America Inc. Customer Service Department at 1-630-350-8200.

GENERAL EMISSIONS WARRANTY COVERAGE - California Only -

FUJI warrants to the ultimate purchaser and each subsequent purchaser that the SORE (1) has been designed, built, and equipped so as to conform with all applicable regulations; and (2) is free from defects in materials and workmanship that cause the failure of a warranted part to conform with those regulations as may be applicable in the terms and conditions stated below.

- a) The warranty period begins on the date the engine is delivered to an ultimate purchaser or first placed into service. The warranty period is two years.
- b) Subject to certain conditions and exclusions as stated below, the warranty on emissions related parts is as follows:
 - (1) Any warranted part that is not scheduled for replacement as required maintenance in your owner's manual is warranted for the warranty period stated above. If the part fails during the period of warranty coverage, the part will be repaired or replaced by FUJI according to subsection (4) below. Any such part repaired or replaced under warranty will be warranted for the remainder of the period.
 - (2) Any warranted part that is scheduled only for regular inspection in your owner's manual is warranted for the warranty period stated above. Any such part repaired or replaced under warranty will be warranted for the remaining warranty period.
 - (3) Any warranted part that is scheduled for replacement as required maintenance in your owner's manual is warranted for the period of time before the first scheduled replacement date for that part. If the part fails before the first scheduled replacement, the part will be repaired or replaced by FUJI according to subsection (4) below. Any such part repaired or replaced under warranty will be warranted for the remainder of the period prior to the first scheduled replacement point for the part.
 - (4) Repair or replacement of any warranted part under the warranty provisions herein must be performed at a warranty station at no charge to the owner.
 - (5) Notwithstanding the provisions herein, warranty services or repair will be provided at all of our distribution centers that are franchised to service the subject engines.
 - (6) The owner must not be charged for diagnostic labor that leads to the determination that a warranted part is in fact defective, provided that such diagnostic work is performed at a warranty station.
 - (7) FUJI is liable for damages to other engine components proximately caused by a failure under warranty of any warranted part.
 - (8) Throughout the engine warranty period stated above, FUJI will maintain a supply of warranted parts sufficient to meet the expected demand for such parts.
 - (9) Any replacement part may be used in the performance of any warranty maintenance or repairs and must be provided without charge to the owner. Such use will not reduce the warranty obligations of FUJI.
 - (10) Add-on or modified parts that are not exempted by the Air Resources Board may not be used. The use of any non-exempted add-on or modified parts by the ultimate purchaser will be grounds for disallowing a warranty claims. FUJI will not be liable to warrant failures of warranted parts caused by the use of a non-exempted add-on or modified part.

WARRANTY

When warranty repair is needed, the engine must be brought to an authorized service dealer or warranty station's place of business during normal business hours. In all cases, a reasonable time, not to exceed 30 days, must be allowed for the warranty repair to be completed after the engine is received by the authorized service dealer or warranty station.

MAINTENANCE, REPLACEMENT AND REPAIR OF EMISSION-RELATED PARTS

Only warranted engine replacement parts approved by FUJI should be used in the performance of any warranty maintenance or repairs on emission-related parts. If other than authorized parts are used for maintenance, replacement, or repair of components affecting emission control, you should assure yourself that such parts are warranted by their manufacturer to be equivalent to authorized parts in performance and durability. FUJI, however, assumes no liability under this warranty with respect to parts other than authorized parts. The use of non-authorized replacement parts does not invalidate the warranty on other components unless the non-authorized parts cause damage to warranted parts.

PARTS COVERED UNDER THE CALIFORNIA EMISSIONS WARRANTY

The repair or replacement of any warranted part otherwise eligible for warranty coverage may be excluded from such warranty

coverage if FUJI demonstrates that the engine has been abused, neglected, or improperly maintained, and that such abuse, neglect, or improper maintenance was the direct cause of the need for repair or replacement of the part. That notwithstanding, any adjustment of a component that has a factory installed, and properly operating, adjustment limiting device is still eligible for warranty coverage. The following emissions warranty parts list are covered.

- (1) Fuel Metering System
 - (i) Carburetor and internal parts (and/or pressure regulator or fuel injection system).
 - (ii) Air/fuel ratio feedback and control system, if applicable.
 - (iii) Cold start enrichment system, if applicable.
 - (iv) Regulator assembly (gaseous fuel, if applicable).
- (2) Air Induction System
 - (i) Intake manifold, if applicable.
 - (ii) Air filter
- (3) Ignition System
 - (i) Spark plugs.
 - (ii) Magneto or electronic ignition system.
 - (iii) Spark advance/retard system, if applicable.
- (4) Exhaust manifold, if applicable.
- (5) Evaporation Systems
 - (i) Fuel lines.
 - (ii) Fuel line fittings.

HIGH ALTITUDE ENGINE OPERATION

Please have an authorized Robin America service dealer modify this engine if it is to be run continuously above 5000 feet (1500 meters). Failure to do so, may result in poor engine performance, spark plug fouling, hard starting, and increased emissions.

Carburetor modification by an authorized Robin America service dealer will improve performance and allow that this engine meets EPA (Environmental Protection Agency) and California ARB (Air Resources Board) emission standards throughout its useful life.

An engine converted for high altitudes can not be run at 5000 feet or lower. In doing so, the engine will overheat and cause serious engine damage. Please have an authorized Robin America service dealer restore high altitude modified engines to the original factory specification before operating below 5000 feet.

AIR INDEX

To show compliance with California emission regulations, a hangtag has been provided displaying the Air Index level and durability period of this engine.

The Air Index level defines how clean an engine's exhaust is over a period of time. A bar graph scaled from "0" (most clean) to "10" (least clean) is used to show an engine's Air Index level. A lower Air Index level represents cleaner exhaust from an engine. The period of time (in hours) that the Air Index level is measured is known as the durability period. Depending on the size of the engine, a selection of time periods can be used to measure the Air Index level (see below).

Descriptive Term	Applicable to Emissions Durability Period
Moderate	50 hours (engine from 0 to 80 cc) 125 hours (engine greater than 80 cc)
Intermediate	125 hours (engine from 0 to 80 cc) 250 hours (engine greater than 80 cc)
Extended	300 hours (engine from 0 to 80 cc) 500 hours (engine greater than 80 cc)

Notice: This hangtag must remain on this engine or piece of equipment, and only be removed by the ultimate purchaser before operation.

Valve Clearance 0.12^{+0.03}₀ mm (0.0047^{+0.0012}₀ in.)

(Intake and Exhaust) **Note:** Adjust the valve clearance while the engine is cold.

Emissions Durability Period 500 hours
(California only)

WARRANTY

LIMITED ROBIN/SUBARU® ENGINE WARRANTY

(Effective with engines purchased from Robin America, Wood Dale, IL, after November 15, 1993)

Robin America, Inc., a division of Fuji Heavy Industries, Ltd. (herein "Robin"), warrants that each new engine sold by it will be free, under normal use and service, from defects in material and workmanship for a period listed below from the date of sale to the original retail purchaser. Robin's obligation under this Limited Warranty shall be limited to the repair and replacement, at Robin's option, of any part or parts which upon examination is/are found, in Robin's judgment, to have been defective in material or workmanship. It shall be a condition of Robin's obligation under this Limited Warranty that Robin, directly or through one of its Distributors or Service Centers authorized to service the particular engine involved, receive prompt notice of any warranty claim and that the engine or the part or parts claimed to be defective be promptly delivered, transportation prepaid, to such Distributor or Service Center for inspection and repair. All repairs qualifying under this Limited Warranty must be performed by Robin or one of its authorized Distributors or Service Centers.

WARRANTY PERIODS:

Robin Four-Cycle, Air-cooled, Gasoline Engines Limited 3 years Warranty

The repair or replacement of any part or parts under this Limited Warranty shall not extend the term of the engine warranty beyond the original term as set forth above.

LIMITATIONS AND EXCLUSIONS: This Limited Warranty shall not apply to:

1. Bent or broken crankshaft or resultant damage caused by vibration related to a bent or broken crankshaft. Also, damage caused by loose engine mounting bolts or improper or imbalanced accessories or blades mounted to the crankshaft.
2. Repairs required because of prolonged storage including damage caused by old or contaminated fuel in the fuel tank, fuel lines or carburetor, sticky valves or corrosion and rust of engine parts.
3. Repair required due to overheating. (Most often caused by overloaded or clogged or damaged or missing flywheel, fan, inlet air passages, cooling fins, or air shrouds.)
4. Dirt or grit related wear caused by improper air cleaner maintenance (most often resulting in worn piston, piston rings, cylinders, valves, valve guides, carburetor, or other internal components).
5. Broken or scored parts caused by low oil level, dirty, or improper grade of oil.
6. Engine tune-ups and normal maintenance service including, but not limited to, valve adjustment, normal replacement of service items, fuel, and lubricating oil, etc.
7. Any engine which has been subject to negligence, misuse, accident, misapplication, or overspeeding.
8. Any engine that has been installed, repaired, or altered by anyone in a manner which in Robin's sole judgment adversely affects its performance or reliability.
9. Any engine which has been fitted with or repaired with parts or components not manufactured or approved by Robin which in Robin's sole judgment adversely affects its performance or reliability.
10. Instances when normal use has exhausted the life of a component or an engine.

The customer is responsible for all transportation charges in connection with any warranty work.

Robin reserves the right to modify, alter, or improve any engines or parts without incurring any obligation to modify or replace any engine or parts previously sold without such modification, alternation, or improvement.

No person is authorized to give any other warranty or to assume any additional obligation on Robin's behalf unless made in writing and signed by an officer of Robin.

THIS WARRANTY, AND ROBIN'S OBLIGATION HERE UNDER, ARE IN LIEU OF ANY OTHER WARRANTIES OR OBLIGATIONS OF ANY KIND, EXPRESSED OR IMPLIED, INCLUDING ANY WARRANTIES OF MERCHANTABILITY OR FITNESS FOR A PARTICULAR PURPOSE. THERE ARE NO WARRANTIES WHICH EXTEND BEYOND THE DESCRIPTION ON THE FACE HERE-OF. ROBIN SHALL IN NO EVENT BE LIABLE FOR ANY CONSEQUENTIAL OR INCIDENTAL DAMAGES.

This warranty applies to ROBIN/SUBARU products manufactured by ROBIN/SUBARU and sold in the United States and Canada.

To locate your nearest service dealer or learn how to order parts, dial 1-800-277-6246 or visit our website at www.robinsubaru.com.

WARRANTY

LIMITED NON-ENGINE WARRANTY STATEMENT

Techtronic Industries North America, Inc. warrants to the original retail purchaser that this RYOBI® brand pressure washer is free from defect in material and workmanship and agrees to repair or replace, at Techtronic Industries North America, Inc.'s discretion, any defective product free of charge within these time periods from the date of purchase.

Three years if the product is used for personal, family or household use;

One year, if any of the above products are used for any other purpose, such as commercial or rental.

This warranty extends to the original retail purchaser only and commences on the date of the original retail purchase.

Any part of this product found in the reasonable judgment of Techtronic Industries North America, Inc. to be defective in material or workmanship will be repaired or replaced, without charge for parts and labor, by an Authorized Service Center for RYOBI® brand pressure washers (Authorized RYOBI® Service Center).

The product, including any defective part, must be returned to an Authorized RYOBI® Service Center within the warranty period. The expense of delivering the product to the service center for warranty work and the expense of returning it back to the owner after repair or replacement will be paid for by the owner. Techtronic Industries North America, Inc.'s responsibility in respect to claims is limited to making the required repairs or replacements and no claim of breach of warranty shall be cause for cancellation or rescission of the contract of sale of any RYOBI® brand pressure washer. Proof of purchase will be required by the dealer to substantiate any warranty claim. All warranty work must be performed by an authorized Techtronic Industries North America, Inc. service center.

This warranty is limited to one year from the date of original retail purchase for any RYOBI® brand pressure washer that is used for rental or commercial purposes, or any other income-producing purpose.

This warranty does not cover any product that has been subject to misuse, neglect, negligence, or accident, or that has been operated in any way contrary to the operating instructions as specified in the Techtronic Industries North America, Inc. operator's manual. This warranty does not apply to any damage to the product that is the result of improper maintenance or to any product that has been altered or modified so as to adversely affect the products operation, performance or durability or that has been altered or modified so as to change its intended use. The warranty does not extend to repairs made necessary by normal wear or by the use of parts or accessories which are either incompatible with the RYOBI® brand pressure washer or adversely affect its operation, performance or durability.

In addition, this warranty does not cover:

A. Tune-ups – Air filters, gas filters, spark plugs

B. Wear items – Hoses, connector fittings, spray nozzles, wheels, spray wand, detergent bucket, detergent tank

Techtronic Industries North America, Inc. reserves the right to change or improve the design of any RYOBI® brand pressure washer without assuming any obligation to modify any product previously manufactured.

ALL IMPLIED WARRANTIES ARE LIMITED IN DURATION TO THE STATED WARRANTY PERIOD. ACCORDINGLY, ANY SUCH IMPLIED WARRANTIES INCLUDING MERCHANTABILITY, FITNESS FOR A PARTICULAR PURPOSE, OR OTHERWISE, ARE DISCLAIMED IN THEIR ENTIRETY AFTER THE EXPIRATION OF THE APPROPRIATE THREE-YEAR OR ONE-YEAR, WARRANTY PERIOD. TECHTRONIC INDUSTRIES NORTH AMERICA, INC.'S OBLIGATION UNDER THIS WARRANTY IS STRICTLY AND EXCLUSIVELY LIMITED TO THE REPAIR OR REPLACEMENT OF DEFECTIVE PARTS AND TECHTRONIC INDUSTRIES NORTH AMERICA, INC. DOES NOT ASSUME OR AUTHORIZE ANYONE TO ASSUME FOR THEM ANY OTHER OBLIGATION. SOME STATES DO NOT ALLOW LIMITATIONS ON HOW LONG AN IMPLIED WARRANTY LASTS, SO THE ABOVE LIMITATION MAY NOT APPLY TO YOU. TECHTRONIC INDUSTRIES NORTH AMERICA, INC. ASSUMES NO RESPONSIBILITY FOR INCIDENTAL, CONSEQUENTIAL OR OTHER DAMAGES INCLUDING, BUT NOT LIMITED TO EXPENSE OF RETURNING THE PRODUCT TO AN AUTHORIZED RYOBI® SERVICE CENTER AND EXPENSE OF DELIVERING IT BACK TO THE OWNER, MECHANIC'S TRAVEL TIME, TELEPHONE OR TELEGRAM CHARGES, RENTAL OF A LIKE PRODUCT DURING THE TIME WARRANTY SERVICE IS BEING PERFORMED, TRAVEL, LOSS OR DAMAGE TO PERSONAL PROPERTY, LOSS OF REVENUE, LOSS OF USE OF THE PRODUCT, LOSS OF TIME, OR INCONVENIENCE, SOME STATES DO NOT ALLOW THE EXCLUSION OR LIMITATION OF INCIDENTAL OR CONSEQUENTIAL DAMAGES, SO THE ABOVE LIMITATION OR EXCLUSION MAY NOT APPLY TO YOU.

This warranty gives you specific legal rights, and you may also have other rights which vary from state to state.

This warranty applies to all RYOBI® brand pressure washer manufactured by Techtronic Industries North America, Inc. and sold in the United States and Canada.

To locate your nearest Authorized RYOBI® Service Center, dial 1-800-860-4050.



OPERATOR'S MANUAL

GASOLINE PRESSURE WASHER

3000 PSI

RY80030A

WARNING:

The engine exhaust from this product contains chemicals known to the State of California to cause cancer, birth defects, or other reproductive harm.

CALIFORNIA PROPOSITION 65

• **SERVICE**

Now that you have purchased your tool, should a need ever exist for repair parts or service, simply contact your nearest Authorized Service Center. Be sure to provide all pertinent facts when you call or visit. Please call 1-800-860-4050 for your nearest Authorized Service Center. You can also check our web site at www.ryobitools.com for a complete list of Authorized Service Centers.

• **MODEL NO. AND SERIAL NO.**

The model number of this tool will be found on a plate attached to the motor housing. Please record the model number and serial number in the space provided below.

• **HOW TO ORDER REPAIR PARTS**

When ordering repair parts, always give the following information:

- MODEL NUMBER RY80030A
- SERIAL NUMBER _____

Ryobi® is a registered trademark of Ryobi Limited used under license.

TECHTRONIC INDUSTRIES NORTH AMERICA, INC.

1428 Pearman Dairy Road, Anderson, SC 29625
Post Office Box 1207, Anderson, SC 29622-1207
Phone 1-800-860-4050
www.ryobitools.com

Free Manuals Download Website

<http://myh66.com>

<http://usermanuals.us>

<http://www.somanuals.com>

<http://www.4manuals.cc>

<http://www.manual-lib.com>

<http://www.404manual.com>

<http://www.luxmanual.com>

<http://aubethermostatmanual.com>

Golf course search by state

<http://golfingnear.com>

Email search by domain

<http://emailbydomain.com>

Auto manuals search

<http://auto.somanuals.com>

TV manuals search

<http://tv.somanuals.com>