

NEX-FS100U
NEX-FS100UK
NXCAM® Super 35mm Sensor Camcorder

SONY
make.believe



A New World of High Quality Video Production Convenience with
the NXCAM Super 35mm Motion Picture Camcorder

NXCAM

AVCHD

MPEG2 SD

Exmor™
Super35 CMOS

MEMORY STICK™

SD™
XC

GPS



INTRODUCTION

NXCAM Super 35mm Motion Picture Camcorder Providing Creative Expression in High Quality Video Production

Sony's range of NXCAM® models now includes the NEX-FS100U interchangeable lens camcorder featuring a Super 35mm sensor. Developed specifically for shooting motion pictures, this high sensitivity, large format sensor is capable of producing footage with shallow depth of field similar to that of a film camera for a new level of expression.

For even more creative flexibility, the NEX-FS100U also enables extended continuous recording and simultaneous recording of HD video footage for instant backup with an HXR-FMU128 Flash Memory Unit. These and other valuable features make this compact, high performance camera ideal for producing everything from low budget commercials, music videos and documentaries to wedding videos.



SENSOR

"Exmor" Super35 CMOS Sensor for Shooting Motion Pictures

Equipped with a large CMOS sensor equivalent in size to Super 35mm film, like that used in the PMW-F3, the NEX-FS100U enables shooting with similar creative depth of field as film cameras.

The sensor also features an optimum number of effective pixels for shooting HD moving images. At a high 60fps in all-pixel scan mode, this allows images to be captured with less color aliasing, jaggedness and rolling shutter than DSLR cameras, while providing the sensitivity to shoot at a minimum illumination of 0.28lux*¹. Another advantage of Exmor[®] technology is minimal noise when shooting low-light scenes.

* 1 When using a fixed shutter speed of 1/30, auto gain and an iris setting of F1.4

The SEL18200 lens supplied with the NEX-FS100UK enables shooting in illumination as low as 1.5lux when using a fixed shutter speed of 1/30, auto gain and auto iris



Sensitivity



NEX-FS100U

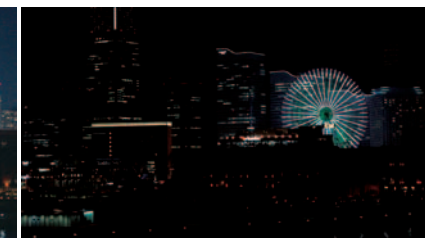

Full Frame DSLR Camera

Depth of Field



NEX-FS100U



Four Thirds Camcorder

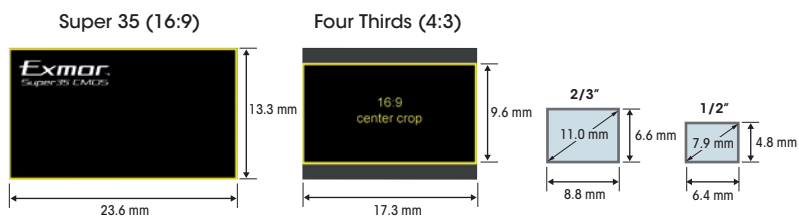

"Exmor" Super35 CMOS Sensor

| | |
|---|--------------------------|
| Gross pixels | Approx. 3,530,000 pixels |
| Effective pixels of moving pictures in 16:9 | Approx. 3,370,000 pixels |
| Effective pixels of moving pictures in 4:3 | Approx. 2,530,000 pixels |

INTERCHANGEABLE LENSES

E-Mount Interchangeable Lens System

The NEX-FS100U features the E-mount Interchangeable lens system. Sony's E-mount interchangeable lenses let you enjoy a level of creative freedom unimaginable with camcorders of the past. All feature precision-crafted optics with aspherical glass elements for compact high performance, and circular iris mechanisms for smooth background defocusing. The NEX-FS100UK comes with the SEL18200(E 18–200mm F3.5–6.3 OSS) lens which boasts 11x zoom power, a quiet AF motor for cleaner sound recording, and Optical Steady Shot® image stabilization with an advanced Active mode that lets you take steady handheld shots while walking around — even without a bulky stabilization rig. An ultracompact SEL16F28 wide-angle lens and SEL1855 3x zoom lens are also available. Thanks to the E-mount's short 18mm flange-back distance, using a mount adaptor allows shooting with a wide range of existing lenses. For example, with the optional LA-EA1 mount adaptor you can take advantage of the abundant A-mount lenses. In addition to Sony, there are four major lens manufacturers that will be producing compatible native E-mount lenses (available Summer 2011).



E-mount lens on the NEX-FS100U



A-mount lens with the LA-EA1 adaptor



Cine-style lens with a third party adaptor

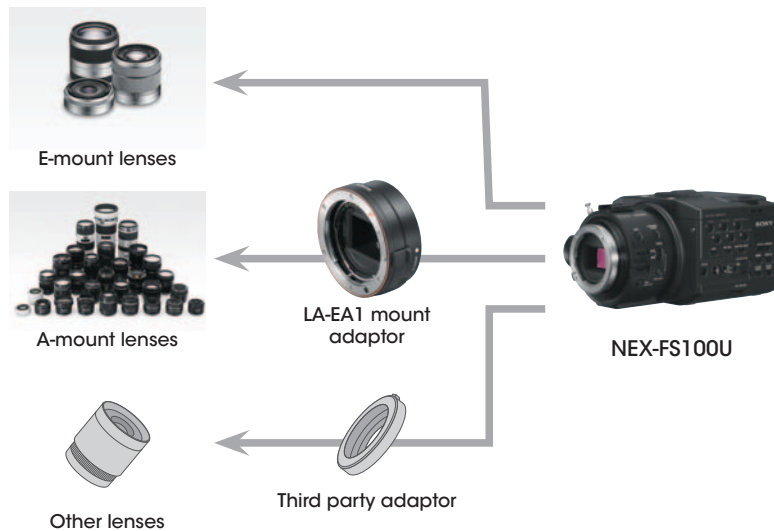

MODULAR DESIGN

New Design Concept Providing the Flexibility for a Variety of Shooting Styles

Featuring a compact, lightweight body with detachable grip, top handle, and viewfinder, the NEX-FS100U is ideal for a wide range of shooting situations.



During hand-held shooting, the angle of the grip can be changed as desired, and start and stop recording with a button on the grip. Secondary record buttons are also available at two locations, at the top and in front of the camera body.

There are 1/4-inch and 3/8-inch screw holes on both the handle and the bottom of the camera body for mounting various peripheral devices, plus three 1/4-inch holes on the top of the camera body. In addition, there is a tape measure hook and a focal plane marker for indicating the image sensor position.



Located on the optical axis, the 3.5-inch-type XtraFine™ LCD panel enables easier and more intuitive framing, especially during hand-held shooting. And the LCD panel can be rotated for stress-free operation when shooting low-angle scenes and digital signage footage. For easier and more precise focusing in daylight, the viewfinder comes with a detachable 1.2x magnifier.

CREATION

1920x1080P Slow and Quick Motion

Recording images at a different frame rate from that used for playback provides the extra versatility of slow and quick motion shooting. Furthermore, the NEX-FS100U enables Full HD (1920x1080) progressive slow and quick motion. Frame rates are selectable from 60fps, 30fps, 15fps, 8fps, 4fps, 2fps and 1fps. So, for example, when recording at 1080/24p, if the frame rate is set to 60fps, images are recorded in 2.5 times slow motion. This means you can create impressive slow motion scenes without the need for troublesome editing.

Note: Slow and quick motion shooting is only available in HD progressive mode. Simultaneous slow and quick motion recording to a memory card and flash memory unit (optional HXR-FMU128) is not available.

Slow Motion Mechanism

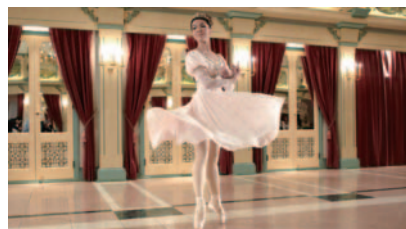
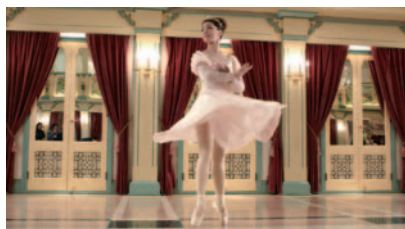
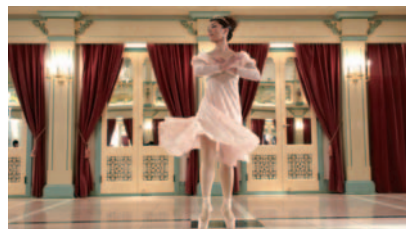
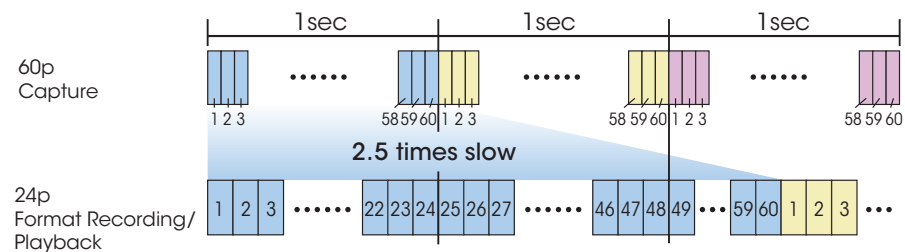

SAFETY & LONG RECORDING

Hybrid Recording



Recording to the directly mountable optional HXR-FMU128 Flash Memory unit allows continuous recording for over 10 hours without changing the recording medium. Simultaneous recording using memory card and HXR-FMU128 is also possible for secure backup when shooting footage that can't be reshot.

Note: HD and SD footage cannot be recorded separately on different recording media.



Compatible Memory Cards Type

* For more information please refer to the specification sheet on the back of this brochure.



Approximate Recording Times*

HD MOVIE

| | | AVC HD 28M (PS) | AVC HD 24M (FX) | AVC HD 17M (FH) | AVC HD 9M (HQ) | AVC HD 5M (LP) |
|----------------------|-------------------------------|-----------------|-----------------|-----------------|----------------|----------------|
| Linear PCM 2ch | 1GB Memory Card | 4 min | 4 min | 6 min | 10 min | 15 min |
| | 2GB Memory Card | 8 min | 10 min | 10 min | 20 min | 35 min |
| | 4GB Memory Card | 15 min | 20 min | 25 min | 45 min | 70 min |
| | 8GB Memory Card | 35 min | 40 min | 55 min | 90 min | 145 min |
| | 16GB Memory Card | 70 min | 80 min | 110 min | 185 min | 295 min |
| | 32GB Memory Card | 145 min | 170 min | 225 min | 375 min | 590 min |
| | HXR-FMU128 (128GB) [Optional] | 600 min | 700 min | 940 min | 1560 min | 2460 min |
| Dolby Digital 2ch | 1GB Memory Card | 4 min | 5 min | 7 min | 10 min | 20 min |
| | 2GB Memory Card | 9 min | 10 min | 10 min | 25 min | 45 min |
| | 4GB Memory Card | 15 min | 20 min | 30 min | 50 min | 90 min |
| | 8GB Memory Card | 35 min | 40 min | 60 min | 105 min | 190 min |
| | 16GB Memory Card | 75 min | 90 min | 120 min | 215 min | 380 min |
| | 32GB Memory Card | 150 min | 180 min | 245 min | 440 min | 770 min |
| | HXR-FMU128 (128GB) [Optional] | 640 min | 750 min | 1030 min | 1830 min | 3200 min |

SD MOVIE

| | SD 9M (HQ) | |
|----------------------|-------------------------------|----------|
| Dolby Digital 2ch | 1GB Memory Card | 10 min |
| | 2GB Memory Card | 25 min |
| | 4GB Memory Card | 55 min |
| | 8GB Memory Card | 110 min |
| | 16GB Memory Card | 225 min |
| | 32GB Memory Card | 460 min |
| | HXR-FMU128 (128GB) [Optional] | 1910 min |

* Recording time varies based on recording conditions.

WORKFLOW

NXCAM® Recording Format

Like other NXCAM® series cameras, the new NEX-FS100U uses the highly efficient AVCHD recording format to capture with excellent image fidelity. Better still, it's ready to shoot with an incredible maximum frame rate of 1920x1080/60p (28Mbps). Standard Definition with DVD format (MPEG-2 PS) recording is also possible.

HDMI 1.4 Output with Embedded Time code for 4:2:2 or RGB 4:4:4 Uncompressed Signal Output

When shooting, the NEX-FS100U provides HDMI 4:2:2 or RGB 4:4:4 uncompressed output with an embedded SMPTE Time code and embedded 2-3 pull-down markers for recording on external disc recorders.

Note: Embedding 2-3 pull-down markers enables material originally recorded at 24p and converted to 60i to be recognized once more as 24p in the HDMI output signal.

RECORDING FORMAT

- Formats: HD: AVCHD/SD: MPEG2 PS (NTSC DVD Format)
- Frame rate: 1920x1080/59.94p, 59.94i, 29.97p, 23.98p
1280x720/59.94p, 720x480/59.94i
- Audio: LPCM/AC3 (2ch) (AC3 only for MPEG2-SD)

| | AVCHD | | | | | MPEG2-SD |
|------------------|----------------|----------------|----------------|---------------|---------------|---------------|
| | PS (28Mbps) | FX (24Mbps) | FH (17Mbps) | HQ (9Mbps) | LP (5Mbps) | HQ (9Mbps) |
| 1920x1080/59.94p | ○ | | | | | |
| 1920x1080/59.94i | | ○ | ○ | | | |
| 1920x1080/29.97p | | ○ | ○ | | | |
| 1920x1080/23.98p | | ○ | ○ | | | |
| 1440x1080/59.94i | | | | ○ | ○ | |
| 1280x720/59.94p | | ○ | ○ | | | |
| 720x480/59.94i | | | | | | ○ |

RECORDING/PLAYBACK

| HD/SD | [HDMI/ COMPONENT] setting | Output resolution | | |
|-------|---------------------------------|-------------------|---------------|-----------|
| | | HDMI OUT | COMPONENT OUT | VIDEO OUT |
| HD | 1080p/480i | 1080p | 1080p | 480i |
| | 720p/480i | 720p | 720p | 480i |
| | 1080i/480i | 1080i | 1080i | 480i |
| | 480p | 480p | 480p | 480i |
| | 480i | 480i | 480i | 480i |
| SD | 1080p/480i | 480i | 480i | 480i |
| | 720p/480i | 480i | 480i | 480i |
| | 1080i/480i | 480i | 480i | 480i |
| | 480p | 480p | 480p | 480i |
| | 480i | 480i | 480i | 480i |

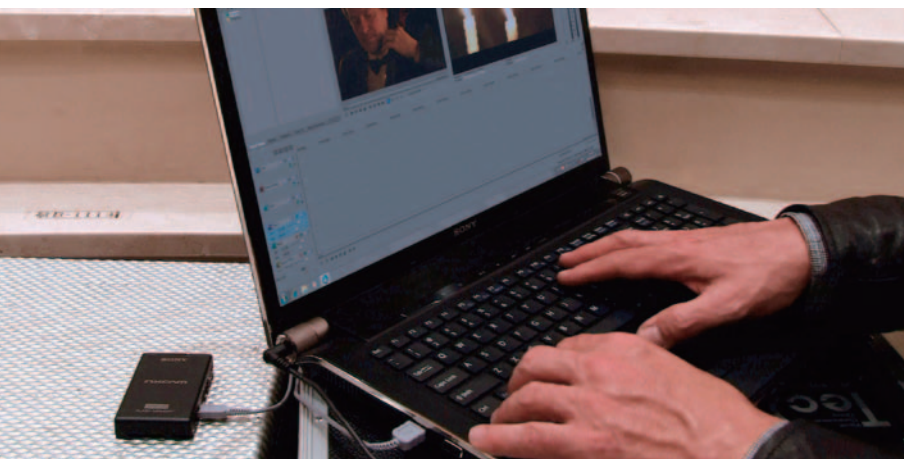

FUNCTION

Other Convenient Features

Location Simplification with GPS Technology

A built-in GPS function automatically records location information at the time of a shoot to AVCHD™ files. The supplied Content Management Utility (CMU) Version 2.0 software can also be used together with map service*. This enables easy confirmation of exactly where footage was shot, which is particularly useful for location shooting and when shooting overseas.

Picture Profile™

Six picture profile settings for different shooting conditions are provided as default settings. Selecting a picture profile for a particular scene offers an easy way to change image quality.

Last Scene Review

Enables fast, one-touch confirmation of the last recorded scene without operating multiple buttons.

*Map service requires PC with internet. Service provided by Google and subject to change without notice.



Expanded Focus

Press a button and this enlarges the center of the displayed image by 2x, a particularly useful feature when making critical focusing adjustments.

Histogram

Onscreen display of a histogram enables easier exposure adjustment. The histogram also shows the point where the zebra pattern appears (the zebra point). This enables confirmation of overall brightness distribution and the brightness level set with the zebra function. As well as preventing overexposure, this is useful as a guide when aiming for optimum exposure of certain parts of an image, such as faces.

Peaking

A peaking function draws a defined line around the subject displayed in the LCD monitor and viewfinder. Peaking sensitivity and color (red, white, yellow) can be selected to enable more precise focusing.

Markers

Center, aspect, safety zone, guide frame and other markers can be displayed on the LCD.

Firmware Update

Sony has implemented a firmware update scheme for future functions.

Sony Opens Up New Era of Super 35mm Digital Production





Optional Accessories



2NP-F970/B
Rechargeable Battery Pack



AC-VQL1BP
AC Adaptor / Charger



VCT-SP1BP
Camcorder Support



VCT-SP2BP
Camcorder Support



LC-EX3TH
Transit Case



HXR-FMU128
Flash Memory Unit



UWP-V1, UWP-V2, UWP-V6
UWP-V Series
Wireless Microphone Systems



HVL-LBPB
Battery Video Light



LPM-770BP
Portable Monitor



ACC-V1BP
Accessory Kit
(Include NP-FV100 and AC-VQV10)



RM1000BP
LANC Remote Commander



RM-1BP
Remote Commander



MS-HX32A (32 GB, 16 GB, 8 GB)
Memory Stick PRO-HG Duo™ media
MS-MT32G (32 GB, 16 GB, 8 GB, 4 GB, 2 GB)
Memory Stick PRO Duo™ media



SF-32N4 (32 GB, 16 GB, 8 GB, 4 GB, 2 GB)
SF-32NX (32 GB, 16 GB, 8 GB)
SD / SDHC Memory Card

Specifications

| General | | | |
|-------------------------------------|---|---|---|
| Weight | Body only | Approx. 2 lb 4oz (1.04 kg) | |
| | w/optional lens w/VF, w/ Battery (NP-F970), w/large eyecup, w/handle, w/MIC (ECM-XM1), w/grip, w/o gripbelt | Approx. 6 lb 1oz (2.76 kg) | |
| Dimension (W x H x D) | Body only | Approx. 5 x 4 x 7 5/8 inch (126.5 x 101.5 x 193.5 mm) | |
| | w/optional lens, w/VF, w/large eyecup, w/handle, w/MIC (ECM-XM1), w/grip, w/o gripbelt | Approx. 7 1/8 x 7 5/8 x 20 1/2 inch (178 x 192 x 519.5mm) | |
| Power requirements | Power Requirements (AC adaptor / Battery) | 8.4V / 7.2V | |
| Power consumption | w/ ECM-XM1 and LCD with normal brightness | 5.6W (w/ supplied lens) *When Flash Memory Unit HXR-FMU128 is used, the average power consumption increases about 1.1W | |
| Operating temperature | | +32 to +104 deg F (0 to +40 deg C) | |
| Storage temperature | | -4 to +140 deg F (-20 to +60 deg C) | |
| Continuous Recording Time | Continuous Recording Time | Approx. 510 min (NP-F970 fully charged batt.) | |
| Recording format | Video Format | HD | MPEG-4 AVC/H.264 AVCHD format compatible (1080/60p original format) |
| | | STD | MPEG-2 PS |
| | Audio Format | HD | Linear PCM 2ch, 16bit, 48kHz / Dolby Digital 2ch, 16bit, 48kHz |
| | | STD | Dolby Digital 2ch, 16bit, 48kHz |
| Recording frame rate* | | HD PS (28Mbps) 1920x1080/60p, HD FX (24Mbps) 1920x1080/60i, HD FH (17Mbps) 1920x1080/60i, HD HQ (9Mbps) 1440x1080/60i, HD LP (5Mbps) 1440x1080/60i, HD FX (24Mbps) 1920x1080/24p, HD FH (17Mbps) 1920x1080/24p, HD FX (24Mbps) 1920x1080/30p, HD FH (17Mbps) 1920x1080/30p, HD FX (24Mbps) 1280x720/60p, HD FH (17Mbps) 1280x720/60p, SD/STD HQ (9Mbps) 720x480/60i, SD/STD HQ (9Mbps) 720x480/60i (24p Scan), SD/STD HQ (9Mbps) 720x480/60i (30p Scan) | |
| Recording/Playback time | | 170 min (2h 50m) with 32GB Memory Stick PRO-HG Duo HX at FX(24Mbps) Linear PCM 2ch recording | |
| Lens (supplied with NEX-FS100UK) | | | |
| Lens Mount | | E-mount | |
| Model Name | | SEL18200 | |
| Product Name | | E 18-200mm F3.5-6.3 OSS | |
| Equivalent 35mm-format focal length | 16:9 | 28.8 - 320mm | |
| | 4:3 | 36- 400mm | |
| Zoom ratio | | 11.1x | |
| Filter Diameter | | 67mm | |
| Camera Section | | | |
| Imaging device | | *Exmor™ Super35 CMOS Sensor | |
| Gross pixels | | Approx. 3,530,000 pixels | |
| | Effective pixels of moving pictures in 16:9 | Approx. 3,370,000 pixels | |
| | Effective pixels of moving pictures in 4:3 | Approx. 2,530,000 pixels | |
| Minimum illumination | | 0.28 lx (1/30 shutter, IRIS F1.4, Auto GAIN) ** | |
| Shutter speed | Auto | 60i/60p: 1/60-1/2000, 30p: 1/30-1/2000, 24p: 1/48-1/2400 | |
| | Manual | 60i/30p/60p: 1/3 - 1/10000, 24p: 1/3 - 1/10000 | |
| Slow & Quick Motion function | Rec Format | 1080/60p, 1080/30p, 1080/24p | |
| | Frame Rate | 60fps, 30fps, 15fps, 8fps, 4fps, 2fps, 1fps | |
| | Shutter Speed | 1/scan frame rate - 1/10000(Manual) | |
| White balance | | Auto, Outdoor (5800K), indoor (3200K), One-push (Touch panel) | |
| Inputs/Outputs | | | |
| Audio input | | XLR 3-pin (female) (x 2), LINE/MIC/MIC +48 V selectable | |
| Composite output | | RCA Type (x 1) | |
| Audio output | | RCA type (CH-1, CH-2) | |
| Component Video Output | | RCA Type (x 3) via Mini-D jack | |
| USB | | USB device, mini-AB/Hi-Speed (x 1) | |
| Headphone output | | Stereo mini jack (x 1) ø3.5mm | |
| Remote | | Stereo mini-mini-jack (ø2.5mm) | |
| HDMI output | | HDMI connector (x 1) | |
| Built-in LCD monitor | | 3.5 inch-type, XtraFine LCD, approx. 921,600 dots(1920 x 480), 16:9 aspect ratio | |
| Recording Media | | | |
| Type | | Memory Stick PRO Duo(Mark2), Memory Stick PRO-HG Duo, Memory Stick PRO-HG Duo HX, SD/SDHC/SDXC Memory Card *** | |
| Supplied Accessories | | | |
| | | AC-VL1 AC Adaptor/Charger, Power cord (mains lead), NP-F770 InfoLITHIUM Rechargeable Battery Pack, RMT-845 Wireless Remote Commander, CR2025 Lithium Battery (Installed), Component video cable, A/V connecting cable, USB cable, VMC-UAM1 USB Adaptor Cable, Large LCD viewfinder, Large eyecup, ECM-XM1 Microphone, Wind Screen, Handle, Grip, Flash memory unit jack cover, Body cap (attached to the camcorder), Accessory shoe plate, DK-415 Connecting cord, CMU2.0 Application Software (CD-ROM), Manuals for Interchangeable Lens Digital HD Video Camera Recorder (CD-ROM), Operating Guide, SEL18200 Zoom lens (supplied with NEX-FS100UK), Lens hood (supplied with NEX-FS100UK), Front lens cap/rear lens cap (attached to the lens)(supplied with NEX-FS100UK) | |

* Due to variable bitrate, 28Mbps is the maximum bitrate for HD PS mode, and 24Mbps for HD FX mode. The average bitrate is stated for FH, HQ and LP modes.

** 1.5 lx (w/ supplied lens: auto gain, auto iris, 1/30 shutter speed)

*** Class 4 or higher



Dimensions

Unit: inches (mm)

NEX-FS100U

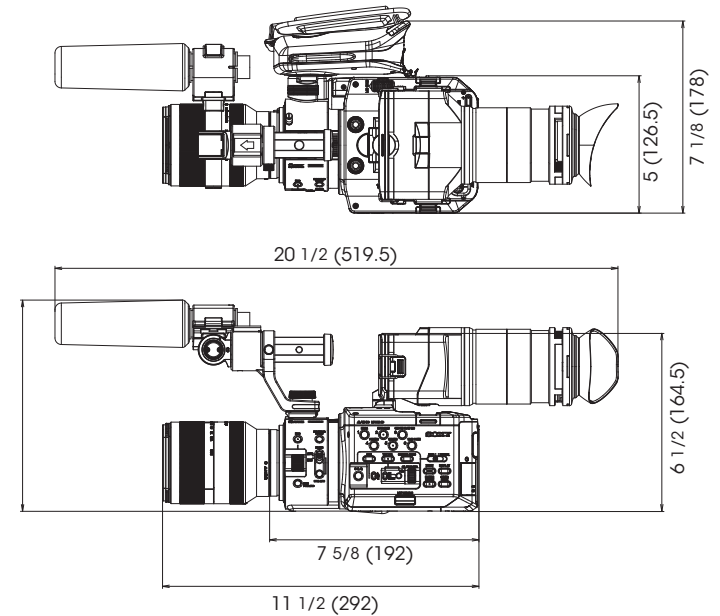

Body only

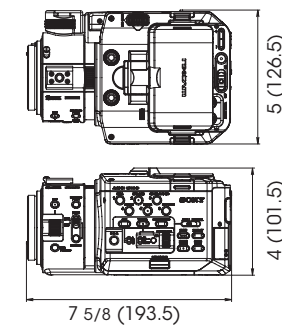

HXR-FMU128

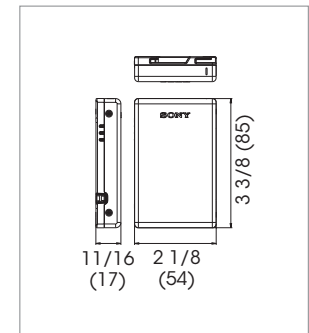

SONY
make.believe

Sony Electronics Inc.
1 Sony Drive
Park Ridge, NJ 07656
sony.com/nxcam

V-2497 (MK10846V1)

© 2011 Sony Corporation. All rights reserved.
Reproduction in whole or in part without written permissions is prohibited.
Features and specifications are subject to change without notice.
Sony, the Sony make.believe logo, α, Exmor, NXCAM, Memory Stick, the Memory Stick logo, Memory Stick PRO Duo,
Memory Stick PRO-HG Duo, Optical Steady Shot, and Picture Profile are trademarks of Sony Corporation.
AVCHD and AVCHD logo are trademarks of Panasonic Corporation and Sony Corporation.
Windows is a registered trademark of Microsoft Corporation in the United States and other countries.
Macintosh and Final Cut Pro are trademarks of Apple Inc.
Dolby is a trademark of Dolby Laboratories.
SD, SDHC and SDXC logs are trademarks of SD-3C, LLC.
All other trademarks are the property of their respective owners.

Free Manuals Download Website

<http://myh66.com>

<http://usermanuals.us>

<http://www.somanuals.com>

<http://www.4manuals.cc>

<http://www.manual-lib.com>

<http://www.404manual.com>

<http://www.luxmanual.com>

<http://aubethermostatmanual.com>

Golf course search by state

<http://golfingnear.com>

Email search by domain

<http://emailbydomain.com>

Auto manuals search

<http://auto.somanuals.com>

TV manuals search

<http://tv.somanuals.com>