

Installation and Operation

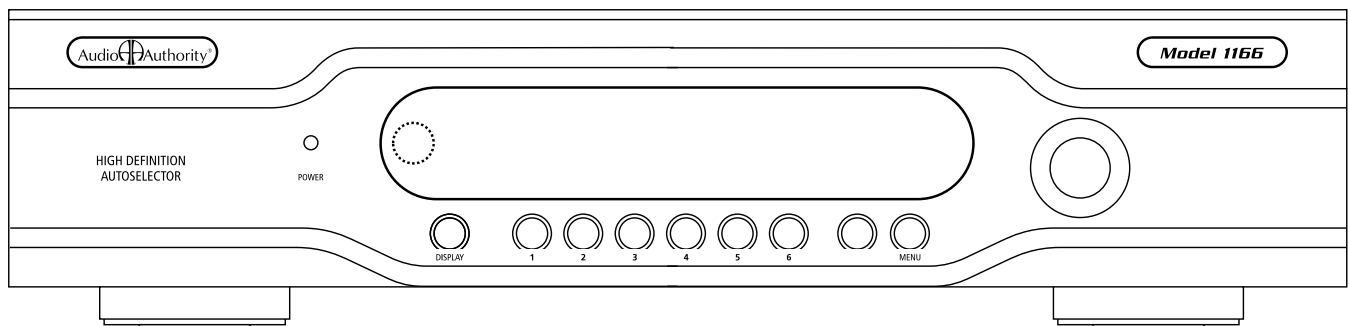

and

Model 1156 and 1166
High Definition AutoSelector™

Audio  Authority®

Installation and Operation Manual



HD Home Theater Routing System

Model 1166

High Definition DVI/Component Video AutoSelector™

Model 1156

High Definition Component Video AutoSelector™



Audio Authority and the Double-A Symbol are registered trademarks of Audio Authority Corp.
AutoSelect is a trademark of Audio Authority. Copyright February, 2007, all rights reserved.
HDMI, the HDMI logo and High-Definition Multimedia Interface are trademarks or registered trademarks of HDMI Licensing LLC.

Audio Authority® Corporation
Lexington, Kentucky
www.audioauthority.com
800-322-8346

Specifications

Subject to change without notice.

Video Parameter

Signal Type	Component+DVI*
Video Formats	480i/p, 720p, 1080i/p 576i/p
Input/Output Impedance	75 ohms
Input Ground Isolation	No
Gain	1
Gain Accuracy	2%
3dB Bandwidth	100 MHz
Input Coupling	DC
S/N Ratio	62dB
Max Gain/Equalization	1

Audio Parameter

Format	Digital/Analog
Digital Audio Input/ Output Type	Optical+Coaxial In/Out
Input Impedance	75 ohms/50K ohms
Min Load Impedance	75 ohms/10K ohms
Multi-channel Digital	Yes
Frequency Response	10-50KHz
S/N Ratio	75dB
THD+Noise	.02%
Crosstalk	25dB

Power

DC Input Connector	5.5 X 2.1 mm
DC Input/Polarity	18V/Center positive
Power Supply	571-015

*DVI video is only available on the Model 1166. DVI output is limited to the main output and cannot be accessed from any remote Wallplate.

Table of Contents

Specifications	2
Warnings	3
Getting Started	4
General Information	4
Suggested Accessories	4
Carton Contents	4
Other Materials You May Need	5
Panel Descriptions	6
Installation	8
Troubleshooting	13
Operating System (Firmware) Upgrade	13
Entering Source Names and Custom Zones	14
Setup Menu Chart	15
Residential Operation	16
Professional Operation	17
Hookup Diagrams for 1156/66, 1170 and 1176	18
Appendix A: Using Compatible IR Products.	21
Appendix B: RS-232 Control Guidelines	22
Warranty	24

Warnings

To reduce the risk of fire or electric shock, do not expose this unit to rain or moisture.



The exclamation point symbol alerts users to important operating and maintenance instructions in this booklet.

- Read these instructions before installing or using this product.
- This product must be installed by qualified personnel.
- Do not open the cover—there are no user-serviceable parts inside.
- Do not expose this unit to excessive heat.
- Install only in dry, indoor locations.
- Do not obstruct the ventilation slots.
- Clean the unit only with a dry or slightly dampened soft cloth.

Getting Started

- Register your purchase at www.audioauthority.com/register to activate your warranty and for future upgrade notification. Write the serial number from the rear of the 1156 or 1166 on the back of this manual.
- Read these instructions.
- Unpack the product and its accessories.
- Install batteries in the infrared remote control.
- Connect associated equipment (see detailed instructions in the Installation Section and Hookup Diagrams).
- Connect the product to a suitable power outlet using only the power supply furnished.
- Perform desired setup operations; the PC Configuration Utility included on the flash card is recommended.



TIP: To access the menu, press and hold the knob, and touch MENU (or press MENU on the remote).
TIP: To perform password operations, enter “2-3-6, LOAD” on the front panel or remote control.

General Information

The Model 1166/56 High Definition AutoSelector™ complements a wide array of home theater signal sources, video displays and audio systems. It performs selection of up to six input sources by infrared control, by a unique AutoSelect™ process, RS-232 signals, or by manual selection. These inputs may be DVI (1166 only) or component video and digital or analog audio, or combinations of these signal types, all delivered to the viewer with their original vividness, brightness and clarity. A special feature of the Model 1166 is its built-in Component-to-DVI converter, which enables the DVI output to be active regardless of the type of video available at the selected input.

NOTE: This manual addresses Model 1166 and 1156 generally but also includes references to DVI capability which is available only on the 1166. If you are installing a Model 1156, ignore any references to DVI.

AVatrix™ HD Home Theater Routing System

The AVatrix is a configuration of one AutoSelector (Model 1156 or 1166) and one Model 1176 High Definition Cat 5 Matrix Router, which allows up to six remote component video outputs with digital and analog audio. Commercial venues, such as clubs and restaurants, as well as private homes can benefit by using the AVatrix to send selectable video and/or audio to remote locations. Six remote Wallplates (Model 9878) are included, plus Model 1108 IR router. The Wallplates allow individual source selection by IR remote control; the output of each Wallplate can also be controlled by the Model 1166. The 1176 delivers component video, digital and analog audio to each 9878 Wallplate over two Cat 5 cables. The AVatrix is expandable up to 36 remote Wallplate outputs.

MultiDriver Configurations

Not every application requires matrix router capabilities possible with the 1176. In applications where all displays are to carry the same content, use the Model 1170 High Definition Cat 5 MultiDriver™ to drive multiple Cat 5 Wallplates with the same program content as the 1166 main component video output. This configuration still allows switching six sources, but all outputs (up to 36) must show the same source at any given time.

Model 1156 or 1166 Carton Contents (other accessories are included with custom systems or AVatrix)

- Model 1156 or 1166 High Definition Video AutoSelector™
- 18-volt Power Supply
- Model 1105 Infrared Remote Control with batteries
- User Manual
- Flash memory card with operational software and setup files (installed in 1166/56 flash card port)

Other Materials You May Need

- Patch cables (RCA, optical and 3.5mm).
- Infrared emitters and/or infrared remote control receivers—for Model 9878 IR functionality.
- Cat 5e/6 cable—for Models 1170 and/or 1176; consider buying a different jacket color for A and B cables.
- RJ-45 plugs—for Models 1170 and/or 1176; EZ RJ-45 plugs are recommended.
- Professional network cable tester—for Cat 5 cables; continuity testing is not adequate; the twisted pairs must be properly matched for balanced line transmission.

Suggested Audio Authority Accessories

- Model 1170 High Definition Cat 5 MultiDriver™ Expander—each expander allows up to six Model 9878 Wallplates to deliver the same content as the Model 1166 output. Maximum 36 Wallplates per system.
- Model 1172 Audio Interface—one required for each Model 1170 or 1176. Provides a connection point for a separate whole house audio distribution system.
- Model 1176 High Definition Cat 5 Matrix Router—each Router allows up to six Model 9878 Wallplates to select any one of the six source inputs to Model 1166. Maximum 36 Wallplates per system.
- Model 9878 Cat 5 HDTV Connection Plates (Wallplates)—allow Model 1170, 1171, or 1176 outputs to be widely distributed via two Cat 5 cables per Wallplate.
- Model 1192 Rack Mounting Adapters—1166 or 1156 fit 19-inch spacing on EIA rack centers (2 rack units).
- Model 1191 Rack Mounting Adapters—1170 or 1176 fit 19-inch spacing on EIA rack centers (2 rack units).
- Model 1108 IR Router. Plug into the IR Out jack to allow multiple sources to be individually addressed by 9878 Wallplates. For more detail, download the 1108 manual from www.audioauthority.com.
- Model 1183 Active Video DC Blocker—for video sources with DC present in the video output.
- Model 802-567 4-port bus cable—for up to 3 expanders or routers.
- Model 802-568 7-port bus cable—for up to 6 expanders or routers.
- Model 1311 DVI + Digital Audio to HDMI Converter—for HDMI TV displays.
- Model 1312 HDMI to DVI + Digital Audio Converter—for HDMI sources.
- Model 1351 DVI Repeater—for long DVI cable runs.
- Model 1391 HDMI EQ/Extender—for long HDMI cable runs.
- Model 1361 Down Converter—converts component video to composite video.
- Model 1362 Up Converter—converts composite or S-video signals to component video or VGA.
- Model 1365 Video Scaler—converts YPbPr to RGBHV or VGA to YPbPr.
- Audio Authority DVI and HDMI high quality connecting cables and DVI-HDMI adapters.

Video Converter Illustrations

Many possibilities exist for adapting or actively converting various signal types to work with the 1166. Refer to the accessory descriptions above. Dotted lines show alternate configurations.

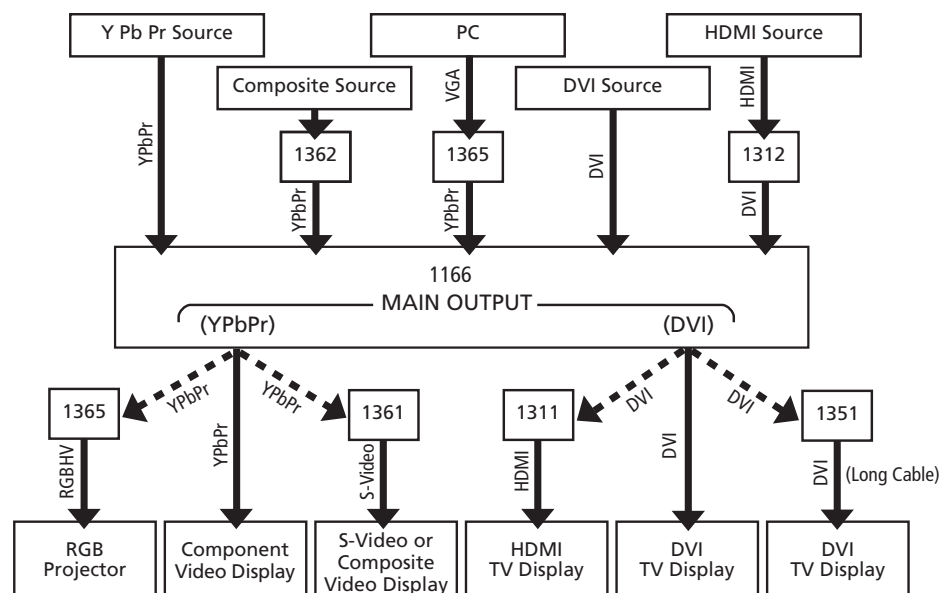

Panel Descriptions

Shown on the page opposite are the front and back views of the 1166. The 1156 is the same, but without DVI connections. Below is a view of the 1105 Infrared Remote Control. Each Model 1166 or 1156 includes one 1105; additional 1105 Remotes may be purchased separately.

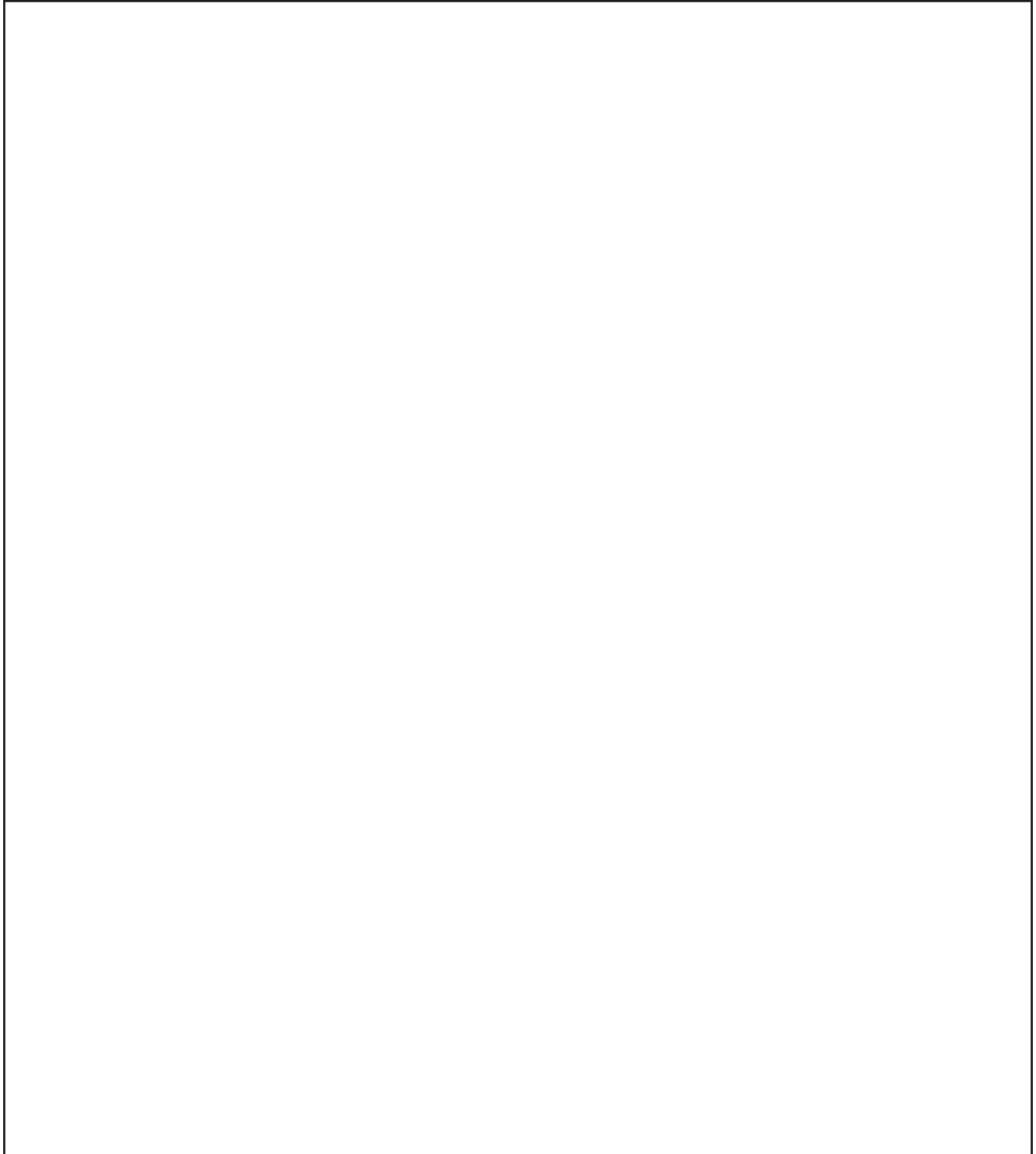

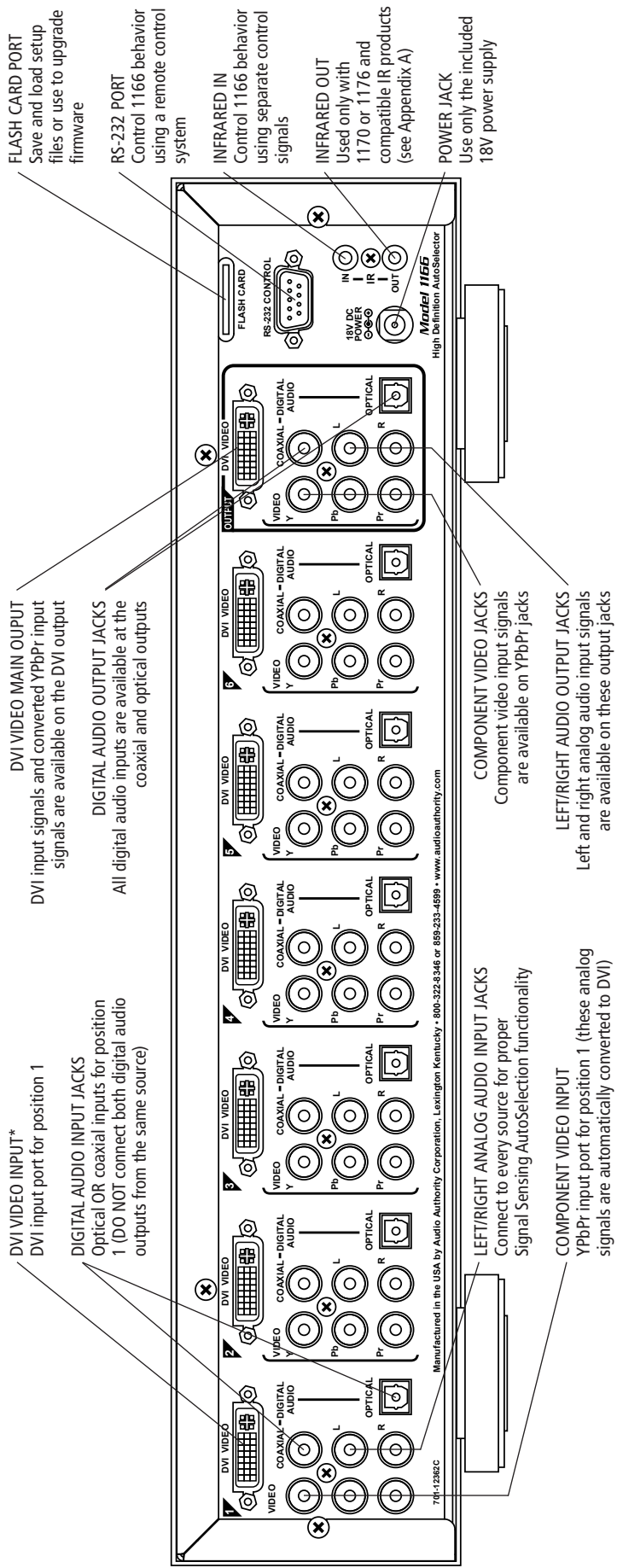
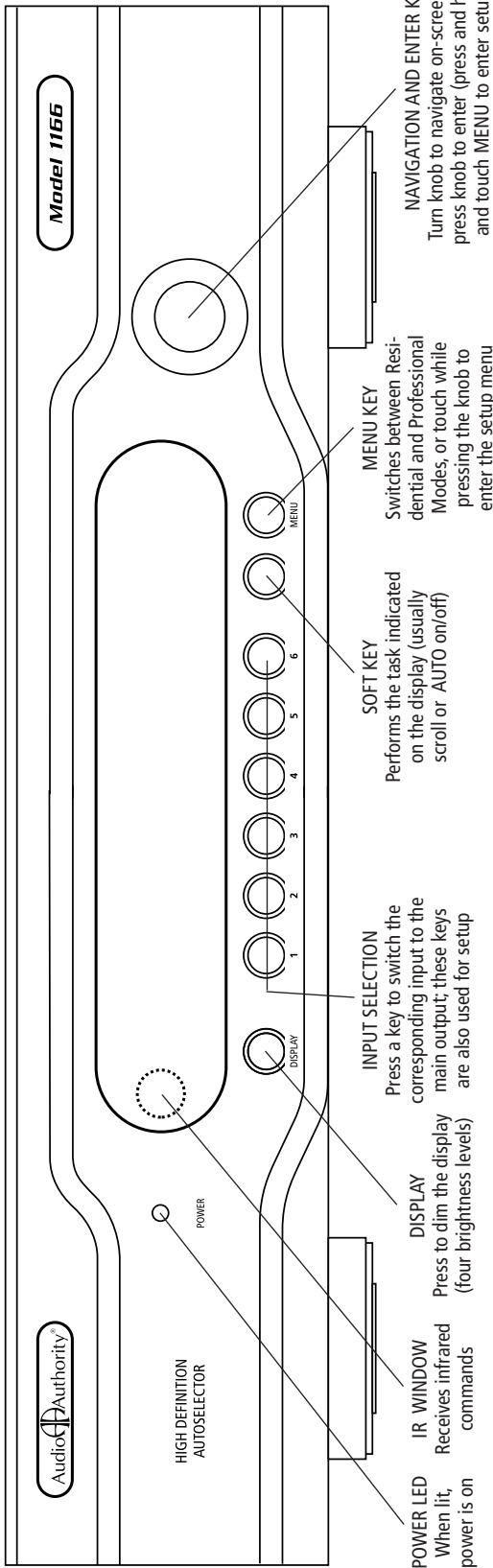

*DVI capability is only available on the Model 1166. DVI signals are not available on 1176 or 1170 Wallplate outputs.

Installation

You may wish to consult with a qualified custom electronics installer if you are inexperienced with DVI, HDMI/HDCP, component video connections and compatibility. If you are installing 1170 or 1176 (AVatrix), you should be familiar with Cat 5 cable termination tools, testing and techniques.

Note: This manual addresses Model 1166 and 1156 generally but also includes references to DVI capability which is available only on the 1166. If you are installing a Model 1156, ignore the references to DVI.

1. **Pre-Setup.** Setup can be performed very conveniently using the Model 1166 PC Configuration Utility. Setup may also be performed through the 1166 front panel controls, or using the 1105 remote).
 - a. To set up the 1166 using a PC, remove the flash card from the slot in the rear panel of the 1166 and insert it in an MMC/SD compatible card reader. The utility should launch automatically in any Windows™ operating system. See page 14 for a screen shot of the Utility. Click the Help button for detailed instructions. If the utility is not already loaded onto the flash memory card, you may download it from our website at www.audioauthority.com/downloads.php at any time.
 - b. After saving the setup configuration file, insert the Flash Card into the card slot on the upper right corner of the back of the Model 1166. Apply power, go to the SETUP menu, choose SAVE/LOAD FILE, and follow the instructions on the screen.
2. **Stacking.** Follow these steps if you are installing Models 1170, 1172, 1176 or other Audio Authority stacking models with your 1156 or 1166. Disconnect power before performing these steps.
 - a. Lay the Model 1166 upside down on a protective surface, such as a terry cloth towel.
 - b. Remove the four feet and the bus port cover and save them and their attaching screws for later use.
 - c. Plug one end of the bus cable (purchased separately) into the port visible through the case opening—apply enough pressure with fingers or a wooden or plastic tool to assure that the plug is completely seated. This bus cable carries component video, digital audio, and analog audio signals from the 1166/56 to the other products in the stack.
 - d. Turn the next product to be stacked upside down (e.g. Model 1170 or 1176), thread the bus cable through its bus ports, and engage its four threaded studs with the four threaded holes in the Model 1166 formerly occupied by the feet.
 - e. Tighten the hex head screws in the bottom of the stacking product in sequence a few turns each, until they are all snug.
 - f. Carefully plug the bus cable into the port. Continue this stacking procedure until all units have been stacked. Always plug the last connector of the bus into the bottom unit, pushing any excess cable into the empty space inside the unit. View the bus through the bus port to be sure all plugs are fully seated. To disconnect a bus plug, squeeze the side latches.
 - g. Install the bus port cover and feet you removed from Model 1166 onto the bottom unit and turn the stack right side up.
 - h. Set the Address dial on each Model 1172 and/or 1176 (Model 1170 does not require addressing)—set the upper-most Model 1176 address to “A”, the next one to “B”, and so on.
 - i. Temporarily plug in the power supplies of all units to a plug strip so that you can turn them all on at one time. The opening screen



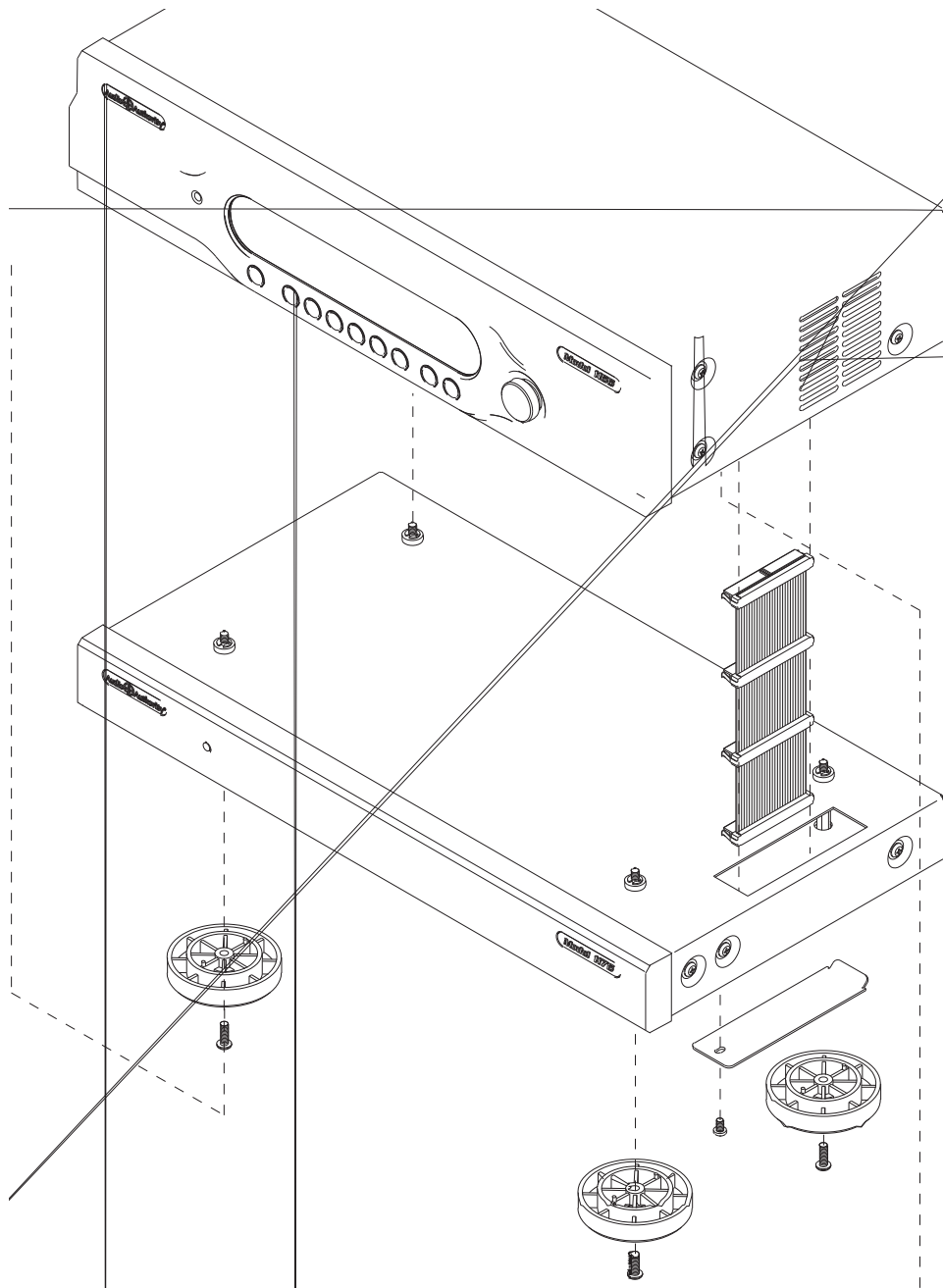

- 3. Rack Mount Adapters.** Do these steps if you are installing this product or a stack of products in a 19-inch equipment rack.
- Remove the cover screws adjacent to the front panel of each product and use them to mount Model 1192 (for Model 1156/66) or Model 1191 (for Model 1170/72/76) rack adapters. *Be sure to place a spacer under the adapters at every screw location.*
 - Use a straight-edge to line up rack adapters on a stack of product before tightening the screws.

CAUTION!
spacers are not used on every adapter screw.

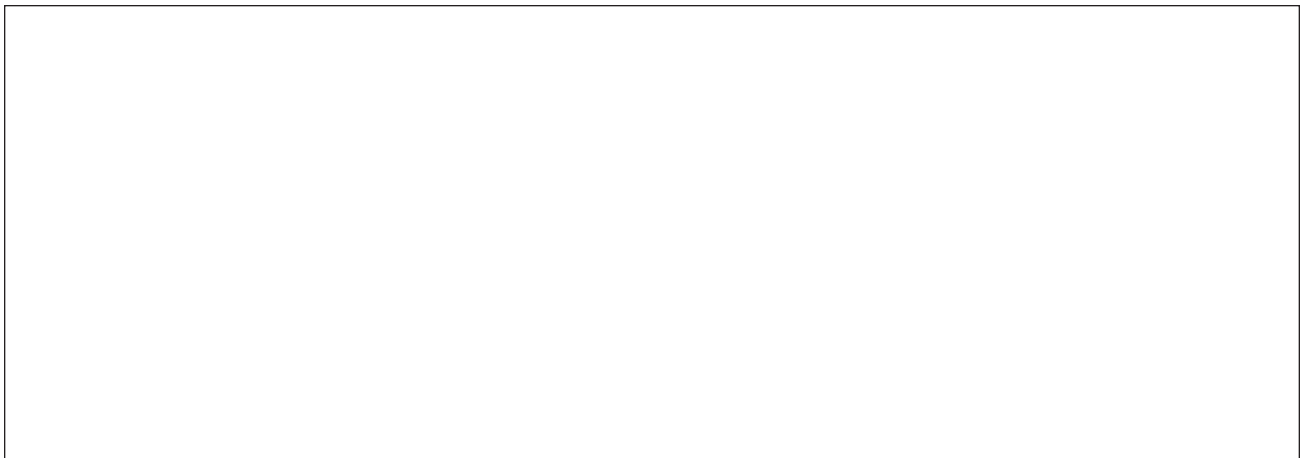
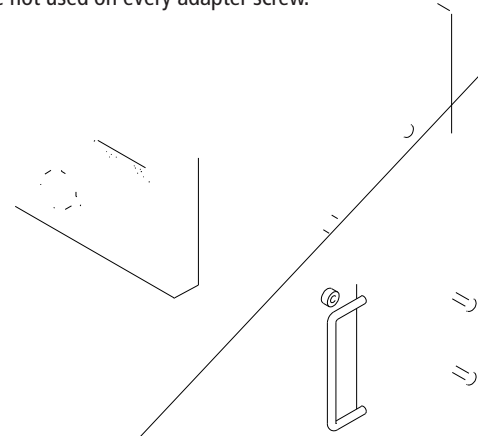

- g. If a source has HDMI but not DVI output, connect Audio Authority Model 1312 between the source and its DVI and digital audio jacks on the Model 1166.
- h. Connect the television monitor and audio system to the Output jacks, using DVI only, or both DVI and component video ports if desired. Use either optical or coaxial digital audio outputs, but NOT BOTH. Use the analog audio output only if the audio system lacks a digital audio input. If the TV monitor requires HDMI, connect an Audio Authority Model 1311 DVI-to-HDMI Converter. NOTE: Some HDMI displays will not work correctly with a DVI signal converted to HDMI after a switching device. If your display works properly at first, but fails to work after being turned off and then on, contact the factory for assistance.

6. Model 1170 or 1176 Wallplate Hookup. If Wallplates are a part of this system, connect them to the stack now. **Caution! Do not connect A and B cables incorrectly. Do not apply system power until cables are tested and A and B connections are verified.**

- a. Pull two lengths of good quality Category 5e or 6 UTP cable from the main system to each Wallplate location. Carefully mark cables of each pair A and B; if they are connected incorrectly, damage to the Wallplate may result. It is best to use a different cable jacket color, or label each end for A and B to ensure proper connection.
- b. Install an RJ-45 plug on each end, using EIA-568B pairing (pins 1-2, 3-6, 4-5, 7-8). Check each cable with a professional network cable tester before plugging it into the 1100 Series system. Continuity testing is not adequate! The twisted pairs must be properly matched for balanced line transmission.
- c. Plug the pairs of cables into the output jacks on the Model 1170s. Carefully plug cables A and B into the correct A and B jacks.
- d. Plug a pair of cables into each Model 9878 Wallplate. Be sure to plug cable A into jack A and cable B into jack B. Do not mount the Wallplates permanently yet.
- e. Adjust the Cable Length Compensation control on each Wallplate according to the distance of that unit from the head end. Set the dial to the nearest number of hundreds of feet of cable distance. After system power up (see 7, below) use an HD source and display to fine tune each cable length compensation setting.
- f. Mount Wallplates *after* initial testing.

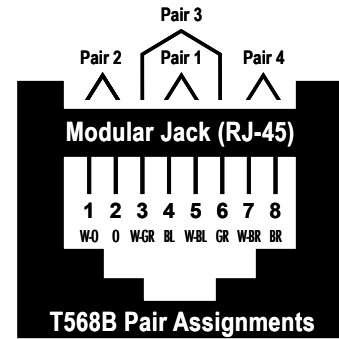

7. Initial Testing. Plug the power supply furnished with each 1100 Series product into its respective unit, and plug the power supplies into a plug strip so that all units can be turned on at one time.

- a. Power indicators on the Model 1166, all stacked units and all installed Wallplates should be on.
- b. The opening screen on the Model 1166 display indicates that the unit is powered and how many expanders have been recognized. That number is zero if the Model 1166 is used alone.
- c. If you see an address error, enter the setup menu and choose Diagnostics. The 1170/72/76 Diagnostics screen allows real time address feedback. Make necessary adjustments to the 1176 and 1172 address dials (see page 8) and exit.
- d. Apply power to all associated equipment. Touch the input selection keys to manually select sources to verify video and audio signal integrity.



Opening screen showing zero 1170s and zero 1176s.

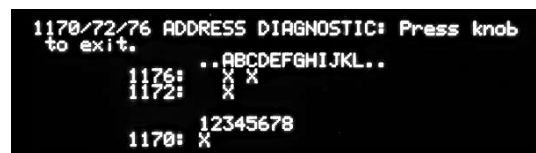

Diagnostic screen showing the second 1176 addressed incorrectly.

- e. If both component video and DVI are connected to the video display, test the display both ways by switching its inputs. Any component video sources should also be shown with the TV in DVI mode.

8. Real-time Setup. If setup configurations were not downloaded from the flash card (page 8), perform desired setup tasks. For convenience, the PC Configuration Utility is recommended for most setup tasks, but all tasks may also be performed using the front panel controls or remote control. As a minimum, it is recommended that you enter custom source names and save your setup configuration to the flash card.

To enter the Setup Menu, press and hold the knob, and touch the Menu key (or simply press Menu on the remote). Use the knob to navigate to each setup option, press the knob to select it, then follow on screen instructions (see page 15 for a Setup Menu Chart).

9. Remote Control Methods. Four different remote control methods may be used with the 1156/66.

- a. Native remote; use Model 1105.
- b. Source or universal remotes; commands can be learned by 1156/66 using the Learn IR Codes setup screen (see section 10 below).
- c. Home automation systems can learn the Model 1166's IR codes along with the codes of the sources and can output a macro containing source controls and Model 1166 selection controls. Follow the manufacturer's instructions to teach the automation system numeric 1 through 6 from the Model 1105, as needed. Some automation systems allow 1105 codes to be downloaded from the manufacturer's website and then loaded into the automation system controller.
- d. RS-232 commands. System controllers capable of RS-232 communication can be connected to the serial port on the Model 1166. To program such controllers, refer to Appendix B in this manual.

10. Using Infrared Control.

- a. If you are using standard handheld remote controls, ensure correct operation by eliminating sources of light pollution such as direct sunlight, fluorescent light, etc.
- b. If you are using a home automation system (such as Crestron, AMX, CQC, or Control4), provide a contact emitter or blaster from the infrared system to stimulate the Model 1166's optical IR receiver, or patch the IR signal directly to the IR input port on the rear panel using a 3.5mm cable (see page 7).

11. Infrared Learning. In addition to using the Model 1105 remote, or using other learning remotes to send 1105 commands, the 1166 can learn to respond to existing commands from source remotes. This control method offers versatility and precision in source selection with a small investment of time to teach the IR commands to the 1166. Following are steps to learn IR codes from source remotes.

- a. Use the Learn IR Codes setup screen to teach the Model 1166 one "key" code for each source unit. For example, for a media player, let the Model 1166 learn its "play" key, then, when that key is pressed to start the player, the Model 1166 will immediately select its output. On a set top box, one might pick the "enter" key to prompt the Model 1166 to switch when a channel has been selected.
- b. Audio Authority Model 1108 IR Router (included in AVAtrix) addresses the problem of controlling multiple identical sources from a Wallplate. The Model 1108, when used with individual IR emitters attached to the sources, routes the IR command from a Wallplate to the appropriate source only.

12. Remote Wallplates. The Cat 5 cables carrying audio and video to the Wallplates also provide a pathway for infrared signals to be returned to the 1170 or 1176.

- a. Plug an Infrared Control Receiver into the 3.5mm jack on each Wallplate used with a Model 1176 that is to have source selection capability. (Use only compatible receivers without power supply—see Appendix A.)

- b. Infrared commands returned from a Wallplate to Model 1176 can immediately select the source to be played on that Wallplate.
- c. **1176:** IR commands returned from a Wallplate to Model 1176 containing code intended for source units or other equipment are repeated through the IR Output jack on the Model 1166. If a compatible infrared control system is in place, and remote sensing of IR inputs from Wallplate locations is desired, patch the IR Output jack to an input of the IR control system. Do not use IR connecting blocks other than Model 1108 (see “Using Compatible Infrared Products” in Appendix A of this manual).
- d. **1170:** All IR commands returned from a Wallplate to Model 1170 are repeated only through the IR Output jack and perform no function within the switching system.

Troubleshooting

If the 1156 or 1166 system fails to respond as expected, use the outline below to find the cause or narrow the possibilities. If your question is not answered in this guide, call Audio Authority Technical Support at **800-322-8346**. Visit www.audioauthority.com for firmware upgrades and other information.

Symptom	Possible Cause(s)
No DVI video on monitor	Non-HDCP monitor*; Passively adapted HDMI source and monitor** (Use Model 1312 to convert source signals)
DVI picture has artifacts	Cable(s) too long or poor quality (Use Model 1351 DVI Repeater for long cable runs)
DVI switching has delay	Normal result of HDCP handshaking
Switches to undesired input with Auto off	Wrong IR code stored
Switches to undesired input in Auto mode	Recording source giving false switch criteria (turn Auto OFF or connect recording source directly to TV)
Does not autoselect a certain source	Digital or analog audio not available or connected; A source is recording
Does not respond to a learned IR command	Wrong IR code learned or IR remote cannot be learned
Does not respond to RS-232	1166 commands not stored in remote control system (see Appendix B)
Does not repeat a certain IR remote	Some IR remotes cannot be processed; IR Output not connected to IR system
Expander is not recognized	Bus cable loose, 1170, 1172 and 1176 incorrectly addressed, or power supply not connected (Use Diagnostics in 1166 setup menu)

* The 1166 will not correct source/display incompatible conditions that may occur when the sources or display are not HDCP compliant.

** The 1166 may not function properly with a system including both an HDMI source and an HDMI display without active conversion using Model 1311 and 1312 (see page 5).

Performing an Operating System Upgrade from a Flash Card

1. Place flash card containing the latest operating system data into card slot at rear of 1156/66.
2. Press encoder knob and touch “menu” key. Setup screen appears. Scroll and choose “Save/Load File”.
3. Scroll and choose “Upgrade 1156/66 operating system.” Upgrade screen appears.
4. Touch in order 2, 3, 6 then (softkey) “Load”.
5. Scroll and select the latest operating system (e.g. “06 Feb 2007 1166 Sys 2.0”).

After you select the version you want the screen displays “Downloading...” This step takes up to a minute. After the screen displays “Completed” the unit reboots several times.

Customizing the 1156 or 1166

One of the features that sets the Model 1156 or 1166 apart from other products is customization. It is easy to apply your own source names, create zones and apply zone names, lock out certain functions, and add contact information. The easiest way to configure the system is to use the PC Configuration Utility, shown at the right; however, any configuration may be performed via the front panel controls and/or remote control. Refer to the Setup Menu Chart below.

Setup Menu Chart

Settings (Options)

Lockout AutoSelect

Prevents AutoSelect from being activated by the front panel or IR.

Lockout Front Panel Keys

Lockout all front panel keys except for Display and the key sequence for Setup Menu access.

Lockout Front Panel IR Detector

Ignores any IR commands visible from the front panel IR window; IR input jack on rear is still active.

Enable Display Blanking

Enables blanking of display after 45 seconds of inactivity (keytouch or IR).

Name the Sources

Assign default, custom and custom long names to each source.

Learn IR Commands

Teach the Model 1166 which IR commands of associated equipment to follow.

Name the Zones

Choose zone names from a list or enter custom zone names.

Assign Output Zones

Divide the array of Model 1176 Wallplate outputs into geographic or functional zones.

Save/Load File

Save Current Setup to Flash Card

Save the current setup configuration to memory card in rear slot. Does not overwrite any existing setup files.

Load New Setup from Flash Card

Scan and load setup data saved from an 1166 or saved from the 1166PC Configuration Utility.

Load Demonstration Setup

Loads example setup including custom short and long source names and 24 simulated remote Wallplate locations.

Load Default Setup

Clears user setup and loads factory default setup.

Upgrade 1156/66 Operating System

Choose from available 1156/66 operating system firmware files on the flash memory card to install a firmware upgrade.

Contact Installer

The installer may enter contact information for the owner's convenience. Enter up to four lines of information, 42 characters per line.

Diagnostics

1176 Address Diagnostic shows letter address of all detected 1176 expanders. Other diagnostics may be added in later system firmware releases.

Naming the Sources

While naming the sources is not required, source names greatly enhance the usability of your entire system. It is easy to customize your source names using the PC Configuration Utility (shown on the previous page), but the names can also be chosen using the 1166 front panel controls.

Each long name can be up to 13 characters, and the short names can be up to 4 characters. The text edit tools are indicated along the bottom of the screen: Case/Number/Symbol, Skip Back, Skip Forward, Overstrike/Insert, and Delete. Touch the corresponding key to use an editing tool. The Case tool allows upper and lower case letters, numbers, or symbols. Note: using all upper case generally yields the best results.



Customizing source names makes it easier to navigate your audio/video system.



The text edit tools are indicated along the bottom of the screen: Case, Skip Back, Skip Forward, Overstrike/Insert, and Delete.

Naming and Assigning Wallplate Zones

Professional mode allows the Wallplate outputs to be monitored and controlled from the 1156 or 1166 front panel. The Zone View displays a list of up to six zones and indicates which source has been assigned to each zone. This view makes it easy to monitor and manage the content being shown on video displays in different rooms or areas from a central location. The number of zones is limited to six.



The Zone view allows the user to see the name of the locations and the sources. Asterisk (*) indicates that one or more of the Wallplates in the zone has been assigned a different source than the one shown.

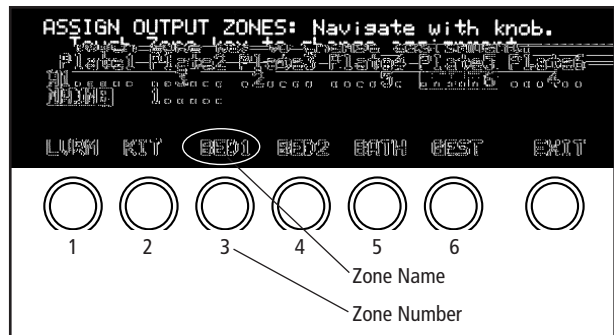

To create custom zones, enter the setup menu and select Name the Zones. Choose names from a list or enter custom short and long zone names for each zone. Exit the Name the Zones screen and select Assign Output Zones. A view of the Assign Output Zones screen is shown above at the right. Any Wallplate can be assigned to any or all zones, and the Main output can belong to any or all zones. Notice that each row of the grid represents one 1176 Matrix Router. To the left is the address letter of each 1176. Above is the output number of the Wallplate output in each column.

To assign a Wallplate to a zone, use the knob or up/down/left/right keys on the remote control to highlight a Wallplate. Touch the number key(s) of the zone(s) to which this Wallplate should belong. (Zones are numbered 1-6 as noted in the example above.) To remove a Wallplate from a zone, touch the number key again.

In the example shown above at right, both Wallplate 1 and Main belong to Zone 1 which is named LVRM. Plate 2 belongs to BED1 (Zone 3) and so on. It is usually helpful to write down a list of Wallplates for each zone before assigning zones, especially if your system is very large or complex.

Residential Operation

The Model 1166 or 1156 allows you to select which of up to six video/audio sources to play through your home theater system. In addition, if you have an AVAtrix, the source being displayed at each Wallplate can be controlled by the Model 1156/66 and, if the Wallplate location is equipped with an infrared receiver, the source can be selected using an infrared remote control in the room where the Wallplate is located. You may wish to use Professional mode if your system is an AVAtrix or includes 1176 matrix expanders. To switch between Residential and Professional, press the MENU key, or the ZERO key on the 1105 remote control.

If your whole-house video distribution system uses Model 1170s, all Wallplate locations automatically display the same program content as the Main Output of the Model 1156/66. Residential mode is appropriate for this type of system.

In Residential mode, the normal screen displays the custom long name of the selected source, the six short names of the sources, which of these sources is currently selected to the Main Output (highlighted short name), which sources are currently active (overscored short name), and whether Autoselect™ is On or Off.

Ask your professional installer whether you should use AutoSelect™ or another method of source selection.



Residential Mode in Unit view. Press Menu key to change to Professional.

Key Sequence Examples for Residential Mode

This table explains how to perform example tasks using front panel controls or IR remote control while in Residential Mode. To navigate using the front panel controls in the Select Remote Sources screen, rotate the knob to move the cursor, press the knob to change directions (up/down vs. left/right).

1105 Remote Control	
Changing the source on the Main Output	Press the desired number key or press the Left/Right Scan keys.
Changing the source on a remote Wallplate	Press Zero; press Unit; use the up/down/left/right keys to highlight the Wallplate; press the Number key for the desired source.
Changing the source for a zone of Wallplates	Press Zero; press Zone (if necessary); use the up/down keys to highlight the desired zone; touch the Number key for the desired source.
Changing the source for all Wallplates	Press Zero; press All; press the Number key for the desired source. (Press Enter to undo.)
Assign a Wallplate to Zone 3	Press Menu; press the down key and select Assign Output Zones by pressing Enter; navigate to the Wallplate you wish to assign using up/down and left/right keys; press 3 for Zone 3.
1166 Front Panel Controls	
Changing the source on the Main Output	Touch the desired Number key or turn the knob.
Changing the source on a remote Wallplate	Touch Menu; turn the knob to navigate; when the desired Wallplate is highlighted, touch the desired Number key.
Changing the source for a zone of Wallplates	Touch Menu; Touch soft key until Zone is indicated; turn the knob to select the zone number desired; touch the desired Number key to assign a source.
Changing the source for all Wallplates	Touch Menu; Touch soft key until All is indicated; touch the desired Number key to assign a source. (Press the knob to undo.)

Professional Operation

The Professional mode is designed to allow easy control of 1176 (AVAtrix) remote Wallplate outputs from the Model 1166 or 1156. If your system does not include an 1176, use the Residential Mode. Switch between Residential and Professional by touching the front panel Menu key or by pressing the Zero key on the remote.

The Professional screen displays the source currently assigned to each Wallplate or zone and allows you to choose a new source for each Wallplate or zone. A special zone view is also available for a more detailed overview of the sources assigned to each zone. If the Wallplate location is equipped with an infrared receiver, the source can also be selected using an infrared remote control in the area where the Wallplate is located.

In Professional mode, the Unit screen displays the array of remote outputs (if Model 1176s are present). Along the bottom, it displays the six short names of the sources, which of these sources is currently selected to the Main Output (highlighted short name), and which sources are currently active (overscored short name). To the left it displays the virtual Main, All and Zone keys. Note: to access Main on the remote, double-press the Source key.



Professional mode in Unit view. Press soft key to change views.



Professional mode in Zone view. (Not available if no zones are assigned.)

Key Sequence Examples for Professional Mode

This table explains how to perform example tasks using front panel controls or IR remote control while in Professional Mode. To navigate using the front panel controls, rotate the knob to move the cursor, press the knob to change directions (up/down vs. left/right).

1105 Remote Control	
Changing the source on the Main Output	Double-press the Source key to indicate Main; press the desired number key or use the Scan keys.
Changing the source on a remote Wallplate	Press Unit; use the up/down/left/right keys to highlight the Wallplate; press the Number key for the desired source.
Changing the source for a zone of Wallplates	Press Zone; use the up/down keys to show the desired zone; touch the Number key for the desired source.
Changing the source for all Wallplates	Press All; press the Number key for the desired source input. (Press Enter to undo.) Main is not included in this command.
Assign a Wallplate to Zone 3	Press Menu; press the down key and select Assign Output Zones by pressing Enter; navigate to the Wallplate you wish to assign using up/down and left/right keys; press 3 for Zone 3.
1166 Front Panel Controls	
Changing the source on the Main Output	Press the soft key until Main is indicated; touch the desired Number key or turn the knob.
Changing the source on a remote Wallplate	Press the soft key until Unit is indicated; use the knob to highlight the desired Wallplate; touch the desired Number key.
Changing the source for a zone of Wallplates	Press the soft key until Zone is indicated; turn the knob to show the desired zone; touch the desired Number key.
Changing the source for all Wallplates	Press the soft key until All is indicated; touch the desired Number key. (Press the knob to undo.)

1166 Source Input and Main Output Connections

Up to six sources may be connected to the Model 1166 or 1156 AutoSelector (1166 shown below). An HDMI source requires a model 1312 HDMI to DVI+Digital Audio Converter. All available connections should be made, with the exception of digital audio; only one of the two digital audio connections should be made for each source. (See page 11 for instructions.)

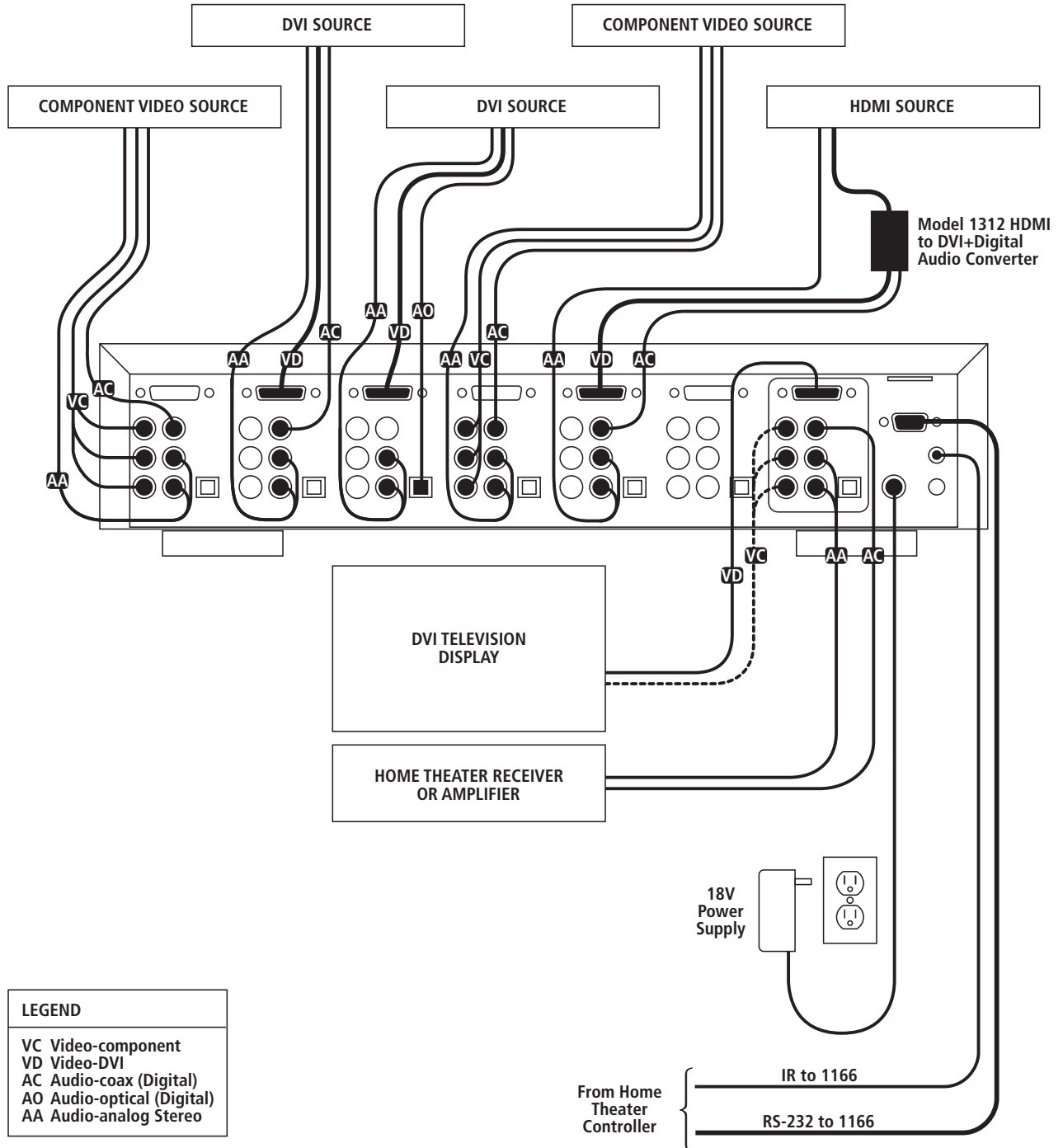

AVatrix™ and other 1176 Matrix Router Configurations

Multiple Wallplates may be connected to a Model 1166 with Model 1176 Matrix Routers. A single 1176 has a capacity of six Wallplates. IR signals sent over Cat 5 through the 1176 are then sent through the 1166 and retransmitted on the IR output jack. IR signals from the 1105 (or other enabled remotes) are interpreted by the 1176 and affect only the output of the Wallplate originating the IR. If the system has multiple sources sharing the same IR code, a Model 1108 Multi-source IR Router should be used.

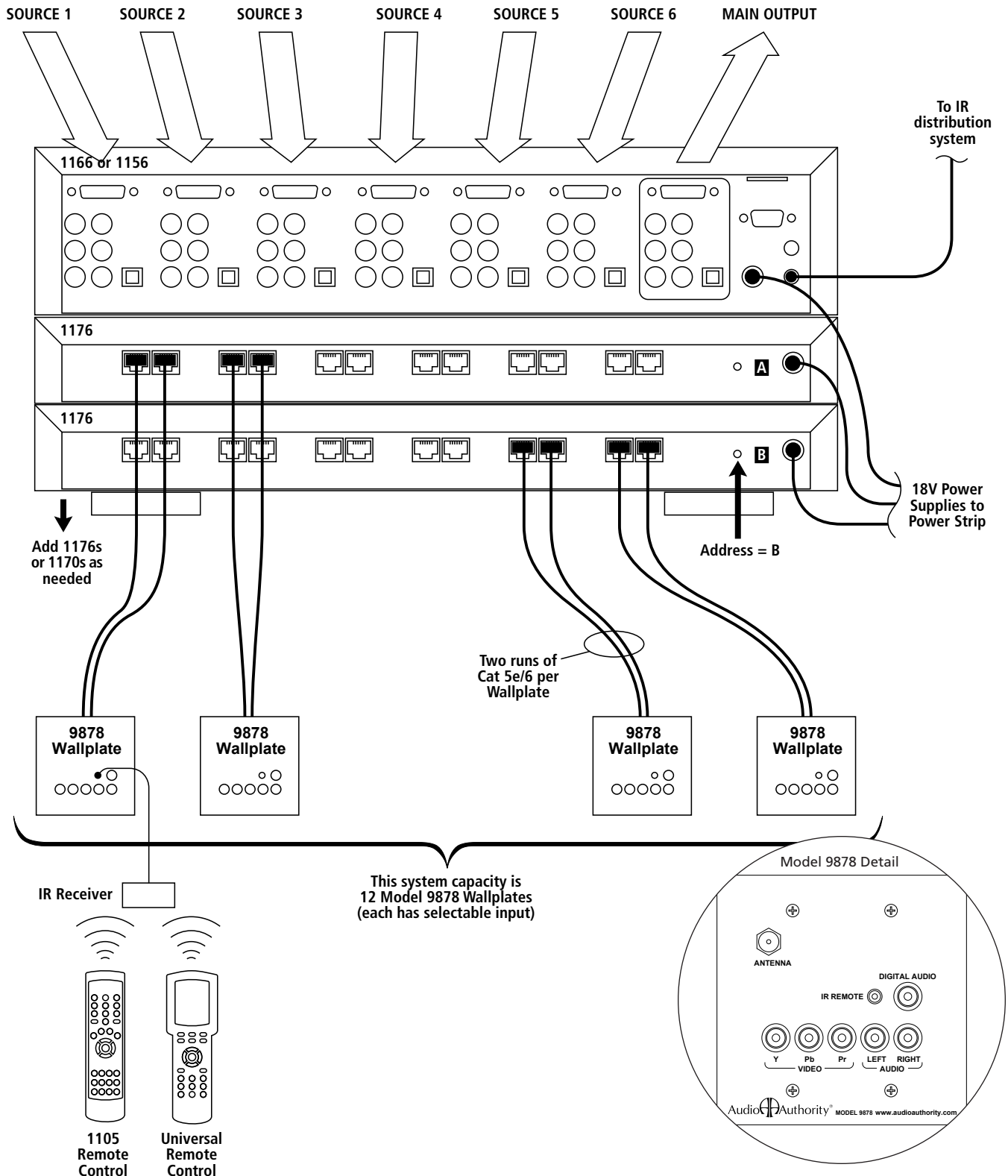

1170 MultiDriver Expander Connections

Multiple Wallplates may be connected to a Model 1166 with Model 1170 MultiDrivers. A single 1170 has a capacity of six Wallplates. IR signals sent over Cat 5 and through to the 1170 are then sent through the 1166 and retransmitted on the IR output jack. 1105 IR signals from Wallplates connected through the 1170 do not control switching.

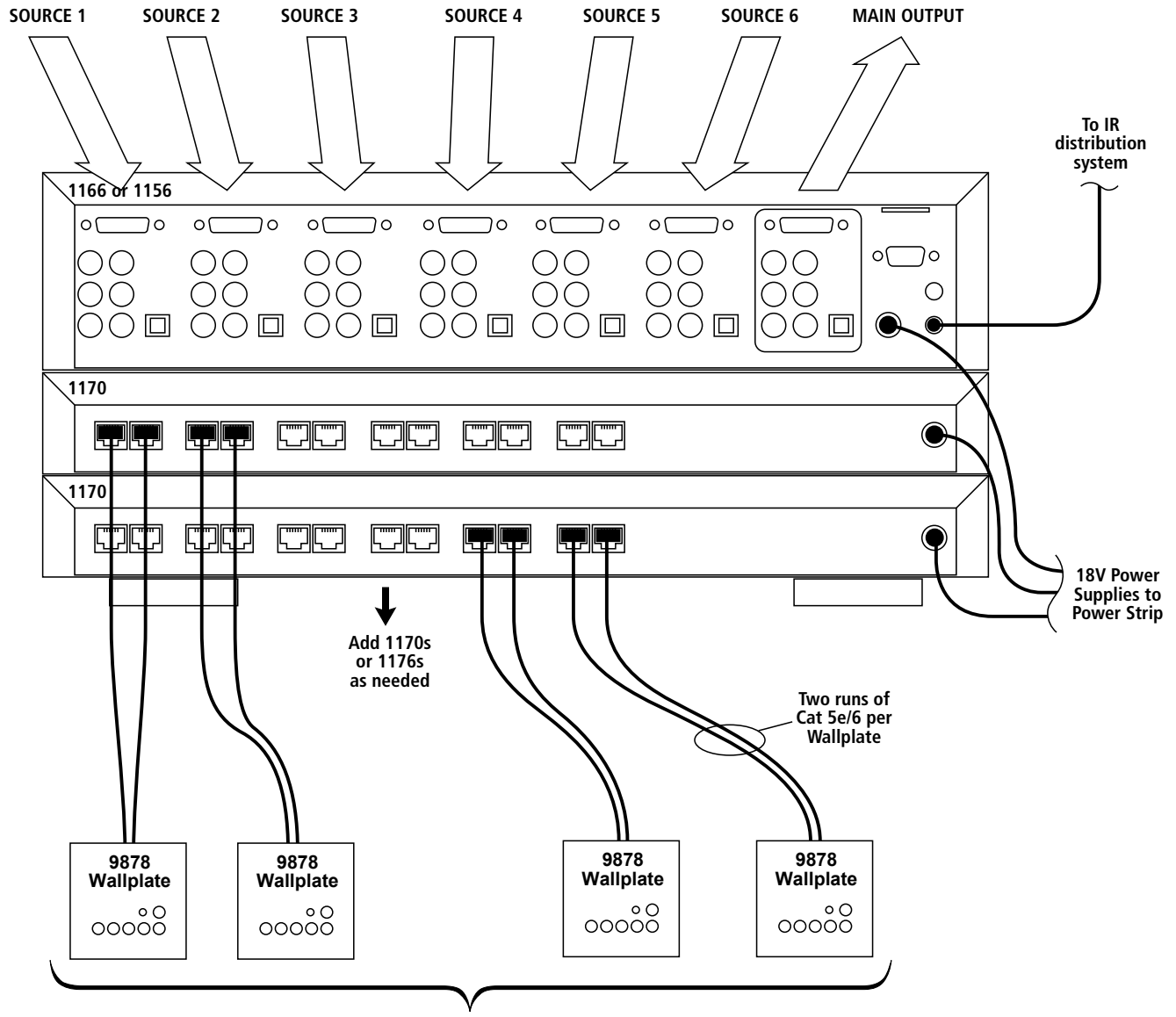

This system capacity is 12 Model 9878 Wallplates
(all units display the same input as 1166 Main Output)

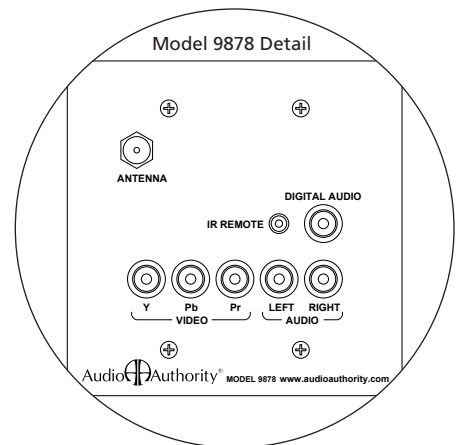

Xantech® 282M
IR Emitter or
equivalent

Do not use a connection
block or signal amplifier
with the 1166 or 1156.

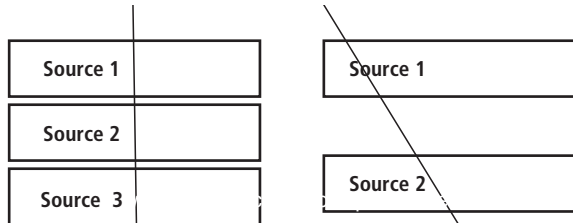

Two-wire
IR blaster or
emitter

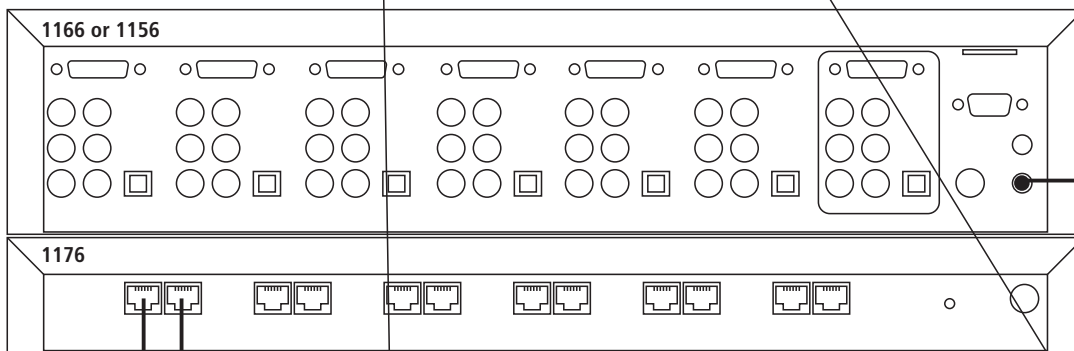

-OR-

Xantech® 291-00
IR Receiver
or equivalent
12 Volt receiver

Connect IR receiver directly
to the Wallplate - DO NOT
use a connecting block.

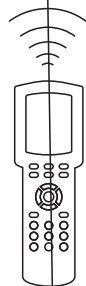

Appendix B: RS-232 Serial Protocol

Model 1166 and 1156 with or without Model 1176 expanders can be controlled via RS-232 from a PC or dedicated controller. Follow the specifications and command protocol described below.

Specifications

Transfer Rate	9600 bps
Data Bits	7 or 8 (Bit 8 is ignored)
Stop Bits	1
Parity	Odd, even, space, mark or none
Flow Control or Data Flow	None
Character type	ASCII

Interface connector	DB-9
Electrical rating	Pins 2 and 3, ± 15 VDC
Pin out	Pin 2, Tx
	Pin 3, Rx
	Pin 5, Ground
	Shell, Ground
Null modem cable	Not required

General Commands

These commands can be used at any time during operation of the 1166 to change the state of selected settings.

Command	Description
N-	Turn AutoSelect Off
N+	Turn AutoSelect On
P	Select Professional screen
R	Select Residential screen
Q-	Unlock AutoSelect
Q+	Lockout AutoSelect
V-	Unlock front panel controls
V+	Lock front panel controls
W-	Unlock front panel optical IR receiver
W+	Lockout front panel optical IR receiver
Y-	Disable display blanking
Y+	Enable display blanking

NOTE: Alpha characters are not case-sensitive. ASCII codes not specified are ignored (i.e. control codes, unused alphanumeric characters, etc.)

Source Selection Commands

Assign or change input sources to the 1166 Main Output, any individual Wallplate output, zone groups of Wallplates, or all Wallplates. In the "Command" column below, actual commands are shown in upper case, and variables are represented by lower case bold characters (commands are not case-sensitive).

Command	Name	Description
Uwxy	Select Unit	Assign Source y to an individual Wallplate wx
Zy	Select Zone	Assign Source y to all Wallplates in a Zone z
Xy	Select All	Assign Source y to all Wallplates
My	Select Main	Assign Source y to the 1156/1166 Main Output

Variables: **w** = Row A-L, **x** = Column 1-6, **y** = Source 1-6, **z** = Zone 1-6.

RS-232 Examples

The general format of commands is as follows:

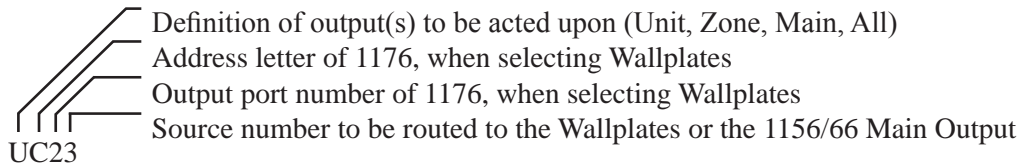

Example 1. To route Input 3 to the Main Output of the 1166, send the following command:

M3 (The 1166 selects source 3 to its output)

Example 2. To change the source assigned to an individual Wallplate, enter “U” followed by the letter of the 1176, followed by the number of the 1176 output from 1 to 6, followed by the number of the input from 1 to 6. To assign input 5 to the 2nd Wallplate on the “C” (third) 1176, send the code:

UC25 (Source 5 is selected to Wallplate C2)

Example 3. To assign the same input source to all the Wallplates, send the following command:

X4 (All Wallplates output Source 4)

Example 4. When Zones have been assigned using the 1166 PC Setup Application or by using the Assign Remote Zones screen, to change the source to an entire zone, enter “Z” followed by the Zone number, followed by the desired source number. To assign source 3 to Zone 2, enter the code:

Z23 (All Wallplates in Zone 2 play Source 3)

NOTE: If zones have not been assigned, no action results from this command.

Query Commands and Responses

Retrieve the status of any part of the 1156/66/76 system using the query commands. A query command sent by the controller will elicit a response according to the following table.

Command	Name	Response
?P or ?R	Screen Mode	P if display is in Professional screen R if display is in Residential screen S if display is in any other screen (e.g. Setup)
?N	Autoselect On/Off	- if AutoSelect is Off + if AutoSelect is On
?Q	AutoSelect Lockout	- if AutoSelect is unlocked + if AutoSelect is locked out
?V	Panel Controls	- if panel controls are unlocked + if panel controls are locked
?W	Optical IR Receiver	- if IR receiver is unlocked + if IR receiver is locked out
?M	Main Output	Number of selected Source
?Uwx	Wallplate Output	Number of Source selected by wallplate wx
?Y	Display Blanking	- if display blanking is disabled + if display blanking is enabled

Variables: w = row A-L, x = Column 1-6



2048 Mercer Road, Lexington, Kentucky 40511-1071 USA
Phone: 859-233-4599 • Fax: 859-233-4510
Customer Toll-Free USA & Canada: 800-322-8346
Website: www.audioauthority.com

Limited Warranty

Should any consumer electronics product manufactured by Audio Authority fail due to defects in materials or workmanship within one year from the date of the original sale to the end-user, Audio Authority guarantees that we will replace the defective product at no cost. Freight charges for the replacement unit will be paid by Audio Authority (Ground service only). A copy of the original invoice from an Authorized Reseller showing the item number and date of purchase (proof-of-purchase) must be submitted with the defective unit to constitute a valid in-warranty claim.

Units that fail after the warranty period has expired may be returned to the factory for repair at a nominal charge, if not damaged beyond the point of repair. All freight charges for out-of-warranty returns for repair are the responsibility of the customer. Units returned for repair must have a Return Authorization Number assigned by the factory.

This is a limited warranty and is not applicable for products which, in our opinion, have been damaged, altered, abused, misused, or improperly installed. Audio Authority makes no other warranties either expressed or implied, including limitation warranties as to merchantability or fitness for a particular purpose. Additionally, there are no allowances or credits available for service work or installation performed in the field by the end user.

Serial Number _____

Custom Installer _____

Telephone Number _____

v 2.0
752-483
2/07

Free Manuals Download Website

<http://myh66.com>

<http://usermanuals.us>

<http://www.somanuals.com>

<http://www.4manuals.cc>

<http://www.manual-lib.com>

<http://www.404manual.com>

<http://www.luxmanual.com>

<http://aubethermostatmanual.com>

Golf course search by state

<http://golfingnear.com>

Email search by domain

<http://emailbydomain.com>

Auto manuals search

<http://auto.somanuals.com>

TV manuals search

<http://tv.somanuals.com>