

User Manual

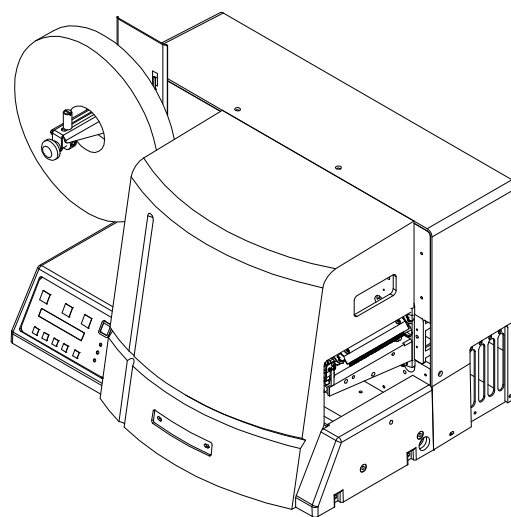

Model 676 - LOKPRINT™

Machine Configuration 2 over 1, 1 over 1 & 2 over 0



AVERY DENNISON
Manual Edition 3.0

20 August 2004

Manual Part Number 371389

This page intentionally blank

Contents

Scope	1
Introduction.....	1
Safety Issues / Warnings	1
Caution.....	1
Warranty Information	2
Description / Specifications	3
Printer Description.....	3
Printer Specification	5
Personal Computer Specifications	6
Customer Responsibility	7
Location of Printer	7
AC Power Line	9
Printer Unpacking / Installation	9
Unpacking.....	9
Inventory of Components.....	10
Fuse Configuration.....	11
Installing the Power Cord	12
Installing the PC Interface Cable	12
Installing the PC Software	12
TCB Dip Switch S2 Settings.....	12
Printer Operation	13
Loading Stock.....	13
Butt Splice	14
Web Guides	14
Print Head Operation	15
Installing Ink Ribbon	17
Splices.....	18
Control Panel Operation	19
Printer Controls.....	19
Indicator Lights.....	20
Display Modes	22

Adjustments	32
Feed Roller Pressure	32
Sensors	32
Sensor Adjustments:	32
Machine Set Up Sequence	33
Maintenance	34
Cleaning	34
Print Head Handling	35
Print Head Replacement	36
Lubrication Procedure.....	39
Electrical Trouble Shooting	40
Power Up / Sign On / Communications	40
Stock / Ink Advance.....	42
Print	43
Mechanical Trouble Shooting	44
Stock	44
Ink	45
Print	45
Appendix A	46
Error Messages	46
Appendix B	47
Software Upgrade Chip Placement Positions.....	47
Front Panel Diagnostic Descriptions.....	49
Appendix C	50
Printhead Life Extension.....	50
Printhead Fail Modes	51
Printhead Cleaning Procedure.....	52
Printhead Installation and Removal Procedures.....	53
Electrical Assembly Drawings	54
Machine Wiring	54
Electrical System Schematic	55
Motherboard Power Connectors	56
Mechanical Assembly Drawings	57
Unwind Assembly Drawing	58
Unwind Parts List	59
Web Guide Assembly Drawing.....	60
Web Guide Parts List.....	61
Drive Assembly Drawing.....	62
Drive Parts List	63
Top - Printhead Assembly Drawing.....	64

Top - Printhead Parts List	65
Bottom – Printhead Assembly Drawing.....	66
Bottom – Printhead Parts List	67
Ink Unwind / Rewind Assembly Drawing.....	68
Ink Unwind / Rewind Parts List.....	69
Web Tension Guide Assembly Drawing.....	70
Web Tension Guide Parts List	71
Drive Belt Routing Drawing	72

Scope

Introduction

This user manual was arranged for the person who is going to operate the machine. The information is arranged in the order that is needed to install and operate the machine. It starts with general information, then to unpacking the crate, installing the stock and ink ribbon, printer operation, control panel operation, and finally care and maintenance of the printer.

We at AVERY DENNISON hope that you will come to appreciate the efforts and quality that has gone into producing your AVERY DENNISON 676LKP Printer and wish to remind you that you are our number one priority. We welcome any constructive comments or criticisms so that we may continue to offer you the best printer in the industry for years to come.

Safety Issues / Warnings

Caution

This machine has some pinch points. All of these areas have been well guarded and it is recommended that the safety features of this machine are never altered or defeated.

Warranty Information

Limited Warranty

AVERY DENNISON extends the following warranties to the original purchaser of a AVERY DENNISON 676LKP that has been installed and operated using recommended procedures and operating conditions.

Parts

Parts found defective in material or workmanship will be replaced at no charge for a period of six months following the machine's shipment date. Parts damaged by negligence, abuse, or normal wear are not covered. AVERY DENNISON 676LKP parts classed as normal wear items include print heads, feed and platen rollers, and knife blades.

Service

Service to replace defective parts as defined above, shall be provided at no charge for a period of six months following the shipment date.

When ordering machines and supplies in the U.S.A., reference all correspondence to the address below.

AVERY DENNISON
One Wilcox Street
Sayre, Pa. 18840
Call: 1-800-967-2927 or (570) 888-6641
Fax: (570) 888-5230

For spare parts, requests for service or technical support

AVERY DENNISON
One Wilcox Street
Sayre, Pa. 18840
Call: 1-800-967-2927 or (570) 888-6641
Fax: (570) 888-5230

For parts and service in other countries please contact your local AVERY DENNISON supplier.

AVERY DENNISON reserves the right to incorporate any modifications or improvements in the machine system and machine specifications which it considers necessary and does not assume any obligation to make said changes in equipment previously sold.

Description / Specifications

Printer Description

The AVERY DENNISON MODEL 676 LKP THERMAL PRINTER (*Figure 1*) is an electronic printer that can print on noncoated polyester stocks. The printer is available as a 2 station single sided printer, a 2 over 1- two-sided printer and as a 1 over 1 - two-sided printer. The printer interfaces to a computer or a main frame system that allows for computer input or even design of a label with AVERY DENNISON'S PCMate Plus's "FORMATTER" program. The printer can generate a complete label printed on one side, with two colors on the top, two sided with either two colors on top with a third on the bottom, or one color on top with a second color on the bottom.

- Design your own labels on a PC
- Computer interface = IBM Compatible
- Mainframe direct interface
- RS232 9 Pin D shell female Serial interface connector

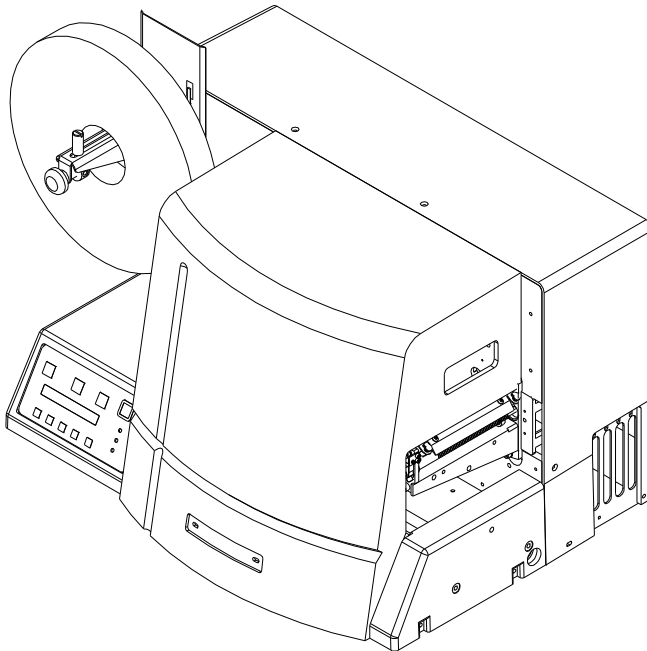

Figure 1 - AVERY DENNISON MODEL 676LKP LABEL PRINTER

Printer Specification

Print method:	Narrow web thermal transfer printer Speed – 3,4, and 5 IPS (76.2, 101.6, and 127mm/second) – w/ Lokprint II, 5” only
Label Size	Min: 1.062" (27mm) web x 1" (25.4mm) feed Max: 2.0" (51mm) web x 1.0" (25.4 mm) feed 2.0" (50.8mm) web x 5.0" (127 mm) feed
Cutting	No cutter included on printer
Print Area	Min: None Max: up to 2" (50.8mm) web x up to 13.875" (352.4 mm) feed
Resolution	300 DPI x 300 DPI
Fonts recommended for 676LKP printers	- Resident in the printer and tested in Lokprint applications: Swiss 721Bold, Swiss 721 Heavy, Swiss 721 black condensed, Swiss 721 Medium. - Tested, must be ordered as an option: Swiss 721 BT 0003 - 7pt up to 96pt (300 DPI), - All rotations 0°, 90°, 180°, 270°
Logos	No restriction on number or size per tag (up to maximum image area) All rotations 0°, 90°, 180°, 270°
Care Symbols	Full Ginetex Care Symbol set and full NAFTA / ASTM Care Symbol Set Fully Scaleable All rotations 0°, 90°, 180°, 270°
Justification	Left, Right, and Center field selectable
Stock	Support for blank sublimation fabric only
Interface	AVERY DENNISON PCL via RS232 serial port - 9 pin D-shell
Control Panel	Push-button printer function with 2 Line x 24 Character International LCD Backlit Display
Dimensions	17.0" (431.8mm) high x 33" (838.2mm) wide with 10" O.D. supply roll (30" (762mm) printer only) x 20.0" (508.0mm) deep
Weight	107 Lbs. (48.5Kg.) Shipping Weight = 130 Lbs. (58.9Kg.)
Electrical	90-132 / 180-265 VAC 50-60Hz 10Amp 1 Ph User selectable through AC entry fuse config.
Temperature	41°F (5°C) to 104°F (40°C)
Humidity	5% to 90% non-condensing

Other Features	<ul style="list-style-type: none"> - Downloading of information while machine is operating - Sequenced Fields - Time/Date Stamping (Both month/day/year and day/month/year format) - Life Counts - Operator adjustable: strobe, cut position, print position, baud rate, and buffer size - Error Detection of: stock out, ink out, print head open, feed open, full stacker, stacker jam, and print head over-temperature - Display: labels left to be cut and stacked in a batch, batch ID, total life inches, total life cuts - Self Diagnostics
Ink Ribbon	AVERY DENNISON high energy dye sublimation
Options	<ul style="list-style-type: none"> - PCMate Plus w/Formatter – 800264 on 3 1/2” disks or 800264CD on CD disk - Spare Parts Kit – 370016 for all head configurations - International Hardware Kit - 370014

Personal Computer Specifications

This specification describes the hardware and application software requirements for the Personal Computer that is used to download to the AVERY DENNISON 676 LKP Printer.

The AVERY DENNISON AVERY DENNISON 676 LKP Printer uses a Windows version of “PcMate Plus / Formatter”. This application will create the tag or label formats (layouts) then fill and transfer data to the printer through the serial port of the computer.

“PcMate Plus / Formatter ” Requires the following:

- IBM® PC or compatible
- Microsoft Windows® 98 2nd edition or higher
(Including Win 2000, ME, NT, and XP)
- 64 Megabytes RAM
- 1 Gigabyte Hard Drive
- Pentium or Pentium Type processor - 400 Mhz or higher
- 3-1/2" floppy drive and CD Rom

DISK DRIVES: You will need a hard disk with at least 100 megabytes of free disk space to store the PCMate Plus program. Additional space will be required to store formats, batches, etc.

Refer to your specific software package for proper installation procedures.

Customer Responsibility

Location of Printer

The printer weighs approximately 250 Lbs (113.4 Kg) and requires a table of sufficient quality and strength to handle this load while the printer is operating. AVERY DENNISON recommends an industrial type worktable having the approximate dimensions of 96" (245.8cm) wide to 30" (76.2Ccm) deep to 32" (81.3cm) high. Refer to Figure 2.

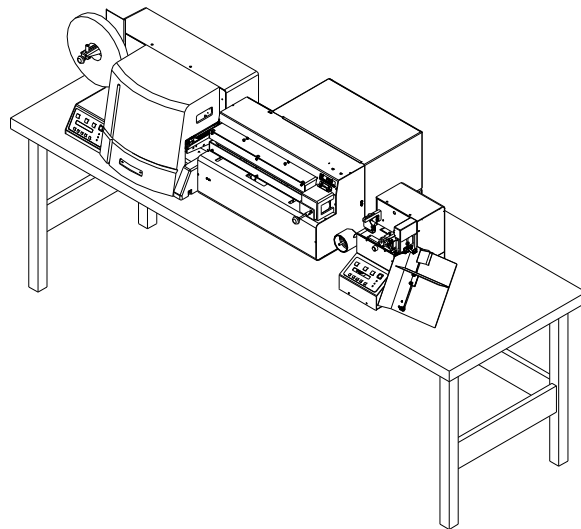

Figure 2 - Recommended Workstation Layout.

The location of the AVERY DENNISON 676 LKP printer should be based on human factors. The printer should be located in an area that maintains optimum flow of your product while providing for the operator's comfort. AVERY DENNISON has taken significant steps to ensure that the operator controls and operations are easily accessible. This goal can only be met, however, if the printer is also located with human factors in mind. These include the height of the printer, the space around the printer, and the accessibility to the printer.

The AVERY DENNISON 676 LKP printer is a high-resolution 300 DPI thermal printer. While AVERY DENNISON has designed the printer to be reasonably quiet, it is recommended to locate the printer in an area where printing and cutting repetitious noise is acceptable.

The AVERY DENNISON 676 LKP printer is designed to operate in conjunction with the AVERY DENNISON Lokprint™ II box and either an Ultrasonic Finisher, a Cold Knife Finisher or a Rewind Unit.

The unit should always be operated with the cover closed to minimize the amount of dust and dirt in the machine.

AC Power Line

EVERY DENNISON requires that the electric service be 10 Amps @ 115VAC or 10 Amps @ 230VAC. This will allow the computer and any additional support or service equipment to be plugged into the same service.

Any electrical service which is supplying a EVERY DENNISON printer or peripheral equipment connected to a EVERY DENNISON printer should follow standard electrical code practices including proper grounding and neutral requirements.

The EVERY DENNISON printer was designed to operate in an industrial setting for extended periods of time; however, the printer is controlled by a microprocessor which is very sensitive to brownouts or power spikes. For this reason as well as the minimum recommended current supply, EVERY DENNISON recommends that a separate "clean" service be installed or reserved for the exclusive use of the EVERY DENNISON printer and its peripherals.

Printer Unpacking / Installation

Unpacking

The EVERY DENNISON printer is shipped in a large cardboard box that may be difficult to move by hand.

DO NOT REMOVE THE PRINTER FROM THE PACKAGE OR UNPACK IN THE SHIPPING / RECEIVING DEPARTMENT.

NOTE: Unpacking in the shipping / receiving department is not recommended for the following reasons.

First: The box in which your EVERY DENNISON printer was shipped allows the printer to be moved with a forklift, forklift or handcart. Because of the weight of the printer, it is easier and safer to use one of these devices to move the printer to its intended installation location.

Second: Leaving the printer in the crate while it is being moved within your facility will help to protect the printer during the movements to this new location. Once the printer has reached its intended location you should begin the unpacking process.

Open the box from top by removing the two (2) banding straps and cutting the tape seam on top of the printer. (See Figure 3).

Remove the plastic over the printer.

Remove all the smaller loss items from in and around the printer.

There is a sleeve to lift the printer from the box for easy removal.

Lift the printer onto the table.

Inspect the machine for shipping damage. If obvious damage is discovered, contact AVERY DENNISON for further instructions - in the U.S.A. at (570) 888-6641. In countries other than the U.S.A. please contact your local AVERY DENNISON supplier.

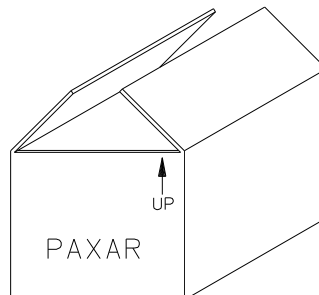

Figure 3 - Shipping Box.

Save the shipping materials to relocate the unit or return to factory for service.

Inventory of Components

The following list shows the additional parts (pieces) that should be included in your AVERY DENNISON 676 shipping crate. If anything is missing, notify AVERY DENNISON immediately - in the U.S.A. at (570) 888-6641. In countries other than the U.S.A. please contact your local AVERY DENNISON supplier.

- AVERY DENNISON 676 LKP "User's Manual"
- A quick-disconnect power cord
- A serial communications cable with adapter
- Optional software ordered to drive the printer.
- Tool kit

NOTE: Some of the above parts may be inside the envelope that contains the tool kit.

AVERY DENNISON 676LKP TOOL KIT (#371391)

241149	Anti-Static Gloves (2)
241132	Anti-Static Wrist Strap
921309	Hex Key Set
101330	9/64" Ball Driver
921304	5/32" Ball Driver
921364	3/16" Long Ball Driver
351156	Chip Removal Tool
371389	676LKP Users Manual
921353	Phillips Head Screwdriver
921338	T-T Printer Cleaning Kit

Fuse Configuration

The main fuse(s) on the AVERY DENNISON 676 LKP are located inside the AC power entry receptacle. The entry has a fuse drawer that holds the fuse(s) and selects the appropriate line voltage. If the number in the window **DOES NOT** match the AC line intended to be supplied to the printer, **DO NOT** plug the power cord in. Reconfigure as follows:

1) Using a flat blade screwdriver, open the AC entry by lifting the tab just above the voltage indicator window.

WARNING: Attempting to open the AC entry with the AC power cord inserted into it will cause damage to the AC entry.

2) Remove the red fuse drawer.

3) Remove all fuses and the fuse jumper if it is present.

4) Insert into the fuse drawer the correct number and style of fuses and fuse jumper for your application.

Configuration Number One: Line voltage between the range of
90 - 132VAC @ 50 - 60Hz 1 Ph

1) Install one 921167 - 10.0A 250V Fast Acting 1/4 x 1 1/4"

2) Install one Fuse Jumper

See Figure FUSE1

Configuration Number Two: Line voltage between the range of
180 - 265VAC @ 50 - 60Hz 1 Ph

1) Install two 921168 10.0A 250V Fast Acting 5 x 20MM

NOTE: The fuse jumper must be removed to install both 5 x 20mm fuses.

The fuses must be between points A and B as shown not B and C.

See Figure FUSE2

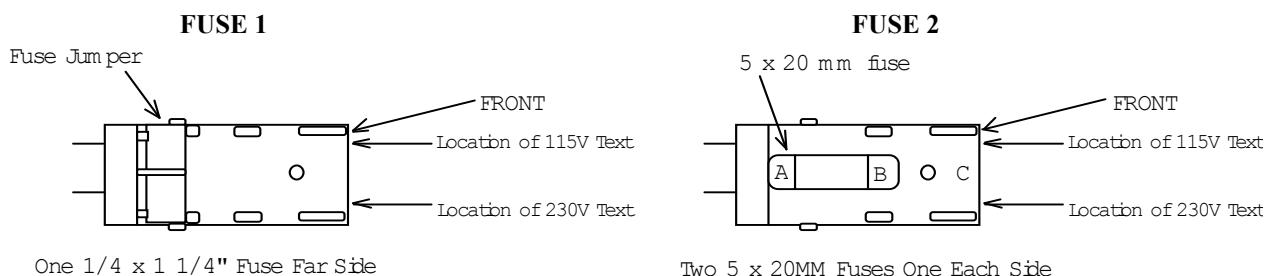

5) Reinsert the fuse drawer into the AC entry with the desired voltage up.

6) Close the AC entry and verify the correct voltage is now visible.

Installing the Power Cord

A power cord is shipped with each printer. The cord for 115-volt printers will use the standard three-prong plug used in the U.S.A. A 230-volt printer and some other 115-volt configurations must have the receptacle end of the connector removed and the proper plug installed. It is the customers' responsibility to have the plug and alteration work done by a certified electrician. AVERY DENNISON supplies printers to many countries with many variations. Therefore we leave this to the customer to make the proper selection for their country.

Installing the PC Interface Cable

The 676 requires a 9-pin RS232 cable. This cable is provided with the printer. If the cable was not found it can be ordered from AVERY DENNISON (Part no. 351124).

The male end of the cable should be connected to the 9-pin D-shell female connector that is located on the right side of the printer. The female end of the cable is made to fit a 9-pin male RS232 connector on the back of the PC.

Installing the PC Software

The software to drive the AVERY DENNISON family of printers is covered in separate documentation. The "Formatter" software to create formats for the AVERY DENNISON 676 printer is a Windows application. The original software "Selfform" will not create formats for the 676. The new "PCMate" package is capable of making formats for all AVERY DENNISON control printers.

PCMate Plus Ver. 3.21.32 will support the 676LKP. Lower versions may not contain the test drivers.

The printer is also capable of operating directly from a mainframe when using the RS232 interface and AVERY DENNISON's PCL command language.

TCB Dip Switch S2 Settings

DIP SWITCH #	DEFINITION	676 LOKPRINT™
8	LOKPRINT™	OFF
7	UNUSED	OFF
6	UNUSED	OFF
5	STACKER	OFF
4	MACHINE TYPE	ON
3	MACHINE TYPE	ON
2	UNUSED	OFF
1	300 DPI	ON

Printer Operation

Loading Stock

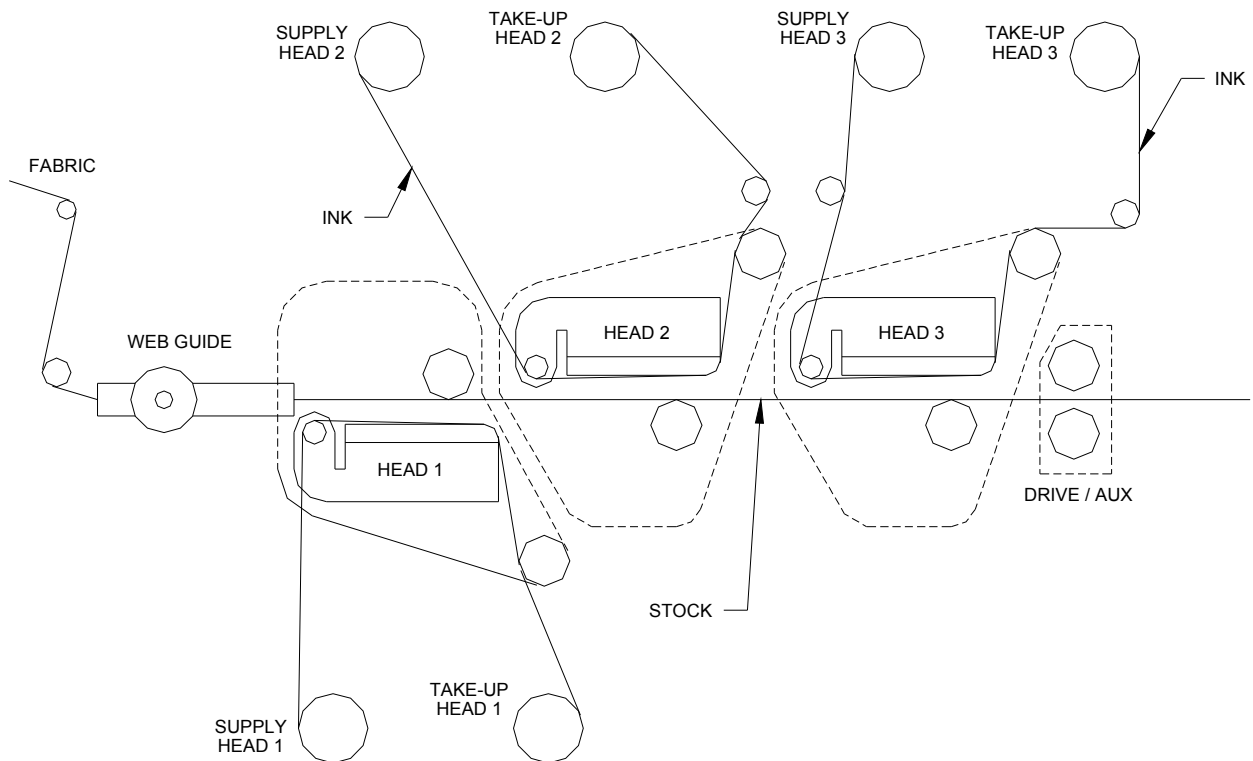

Figure 4 - LOKPRINT® Threading Diagram

Loading Stock For The First Time

- 1) Adjust the unwind width wider than the roll of stock to be loaded. Set the stock roll on the unwind between the guides with the stock unwinding from the top clockwise. Adjust the unwind width down to the stock size with the outer guide contacting the roll. Turn the knob an additional $\frac{1}{2}$ turn clockwise. This will activate the constant backpressure device.
- 2) Adjust the web guides to a width wider than the stock.
- 3) Remove the tape or pull the glued end of the stock loose from the supply roll of stock. Pull off about 2 feet (.5 m) of stock to thread it through the printer.

NOTE: If the material was glued to the core, cut off all material that has glue on any surface.

- 4) Open the hinged cover to the machine.
- 5) Open all print heads that are in use by pulling the release knob and then rotating the print heads into the open latched position. The print stations have a pin in the rear to hold them open.

- 6) Open the feed rollers by rotating the feed pressure knob counterclockwise.
- 7) After looping the leading edge of the stock over the decurler slide it through the web guides. Keep the stock in the center, as the printer is center justified.
- 8) As the stock exits the web guides, continue to slide the stock through the print stations.
- 9) Once the stock reaches the feed rollers it maybe necessary to hold the feed pressure knob open in order to pass between the rollers.
- 10) Check that the stock is centered and tracking straight through the printer. Adjust as needed.
- 11) Allow feed to close (spring loaded). Close the printheads that are in use. Do not run a station closed that is not in use. This will cause premature head failure.
- 12) Rewind any loose stock back onto the supply roll.
- 13) Adjust the web guides on the decurler down to the edges of the stock without deforming the stock.

Butt Splice

NOTE: DO NOT RUN BUTT SPLICES THROUGH THE PRINT STATIONS

The AVERY DENNISON 676 LKP has been designed keeping the operators need to change supplies quickly and often in mind. Re threading the stock is quicker than butt splicing is. If however you have determined a butt splice is necessary, after loading a new roll of stock onto the unwind tape the free ends together. Remove all slack by rotating the supply roll counterclockwise. To prolong print head life it is highly recommended that all hand splices be advanced beyond the print stations before printing is resumes. This can best be accomplished by using the stock presently in the print stations to manually pull the new stock through and into the stacker. Once the butt splice is in the stacker close the feed rollers and those print stations needed for the format.

NOTE: Whenever stock of a different type or width is put on the printer, a sample run should be performed. If the print quality / position is acceptable, you can immediately begin your production run. If the print quality / position needs to be optimized, refer to the Adjustments section and perform the procedure needed to make the necessary improvement.

Web Guides

The AVERY DENNISON 676 LKP printer has been designed with the operators' needs in mind. Therefore there are only two sets of web guides in the printer that need to be changed as the width of the rolls change for various width stocks. Neither of these adjustments require a tool.

The first guide is on the unwind itself. A knob located on the front of the unwind adjusts the width of the guides on the unwind while maintaining center justification. To increase the width, turn the knob counter clockwise - to decrease the width, turn the knob clockwise. Adjust the unwind width wider than the roll of stock to be loaded. Set the stock roll on the unwind between the guides with the stock unwinding from the top clockwise. Adjust the unwind width down to the stock size

with the outer guide contacting the roll. Turn the knob an additional ½ turn clockwise. This will activate the constant backpressure device.

The second set of guides are located on the decurler just to the left of the stock registration funnel. Once a stock is loaded and tracking straight through the machine adjust this set of web guides down to the edges of the stock without deforming the stock. If a large distance is to be covered - loosen the plastic thumb screw and slide the collar into the new position - then retighten the thumbscrew. Fine adjustments of the stocks web position can be made by simply moving the collar as a set in or out. If the guides are too tight, the stock will have rolled up edges.

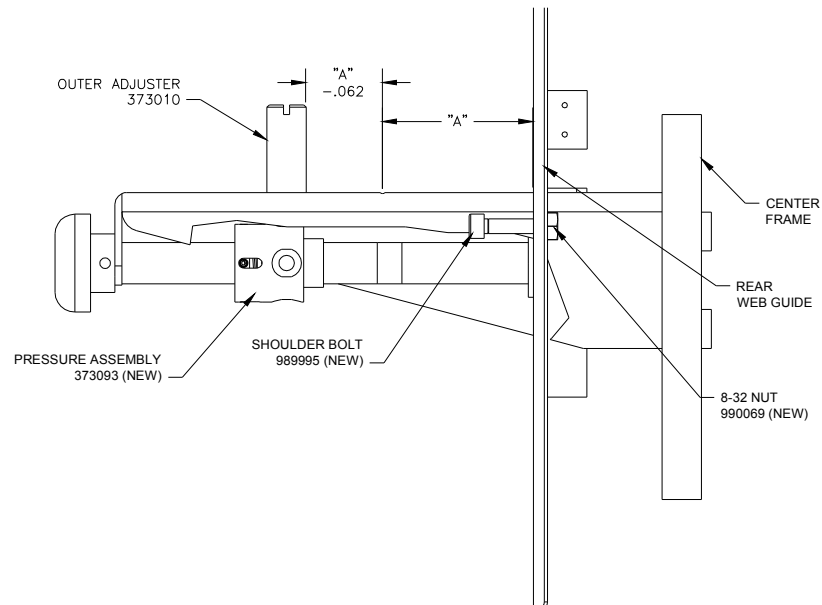

Print Head Operation

The print head modules are to be opened and closed for threading of stock and ink. The unit must also be opened to clean the head and for print head replacement. Later in the manual, under separate headings, cleaning and replacement will be covered.

For clarity the print stations have been assigned numbers one through three from left to right. The far-left print station prints the back, it is print station number one. The center and right print stations print on the top, they are stations two and three. Each print station has an interlock switch that prevents the printer from running with any or all print stations in the open position if that print station is assigned in the format being printed. If a print station is open, the display will read HEAD OPEN STATION X.

WARNING: DO NOT TOUCH THE PRINT HEAD WITHOUT WEARING THE ANTI-STATIC GLOVES AND THE ANTI-STATIC WRIST STRAP.

To open the print heads for threading supplies or cleaning pulling the release knob and then rotating the print head into the open latched position (see figure 5). The top two print stations have a pin in the rear to hold them open. The bottom print station will remain open via gravity - however it has a hole in the rear to hold the print head in a slightly open position to act as a bridge when one is threading stock.

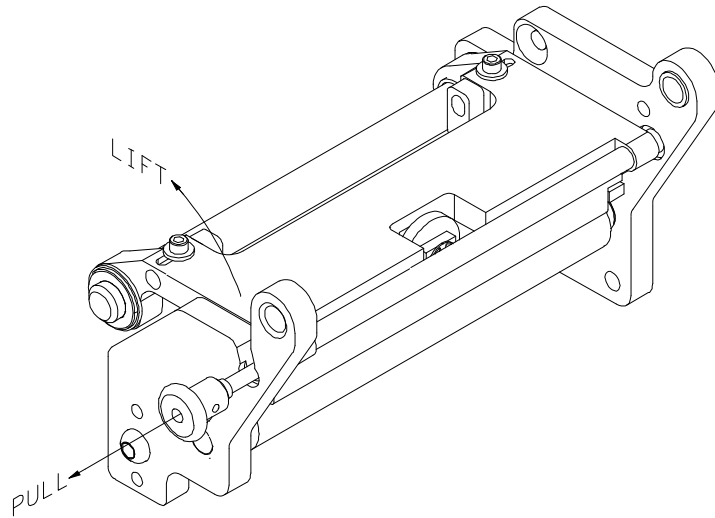

Figure 5 - Print Head Open / Closed

To close the head again pull the release knob and then rotate the print head into the closed latched position (see figure 5).

Installing Ink Ribbon

The ink ribbon comes pre-packaged in a plastic bag. For best results, leave the ink ribbon wrapped in this bag until you are ready to use it in the printer. Use the procedure and diagram below for loading the ink.

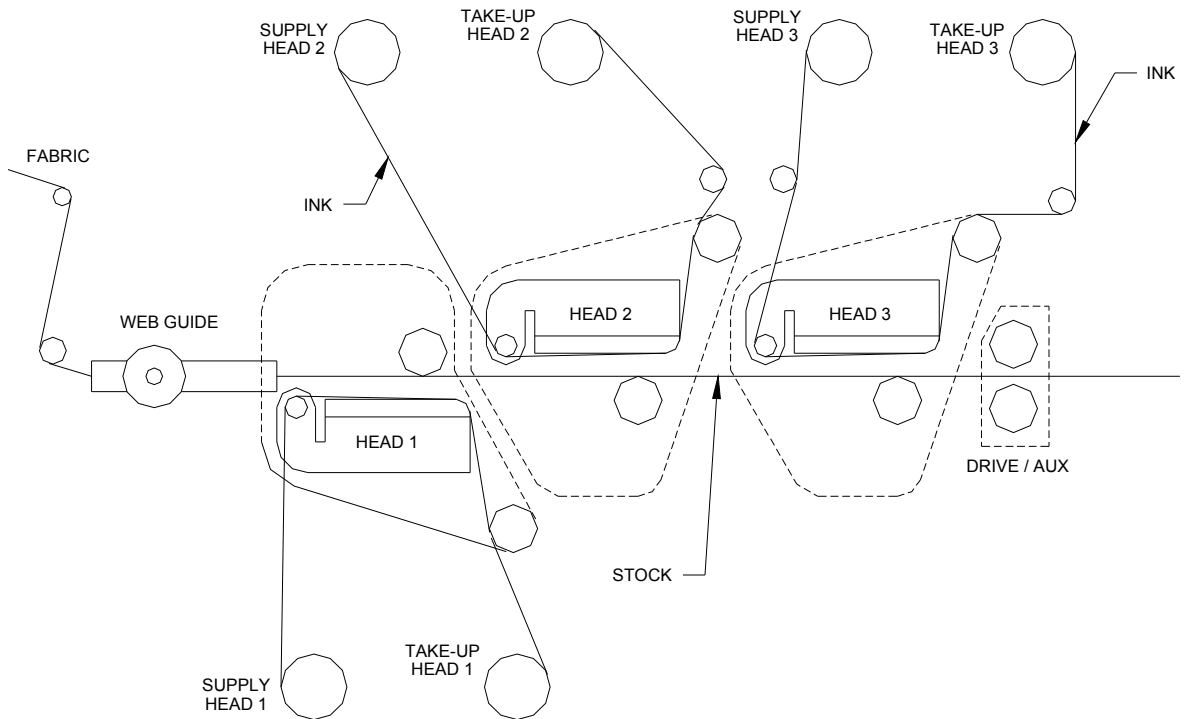

Figure 6

- 1) Unwrap the ink ribbon and put it on the ink-ribbon supply arbor for the print station to be loaded (*Figure 6*) by pressing it on to the arbor when the three slots are lined up.
- 2) Make sure the ink ribbon comes off the roll in the direction shown and is threaded as illustrated (*Figure 6*).

NOTE: A new ink ribbon has a leader that makes it easier to use when threading the ribbon through the print area.

- 3) Place an empty ink-ribbon take-up core on the ink-ribbon take-up arbor for the print station to be loaded. The ink take-up core must be at least as wide as the ink supply.
- 4) Open the print head to the print station being loaded.
- 5) After starting the leader off the supply roll - pull enough ink off to thread through the print station and onto the take up core. The adhesive on the supply roll of ink will be used to fasten the leader to the take up core.

NOTE: Make sure that the ink-ribbon take-up core and the ink-ribbon supply roll are both against the ink backer plate so that the ink ribbon tracks straight through the print station.

Splices

The sonic splices were dropped because they were damaging print heads and would not pull through the web guides.

The new splice tape will not damage the printer, but will NOT print. The new splice may cause a sensor error on the SS Finisher. However, they will sonically cut.

Control Panel Operation

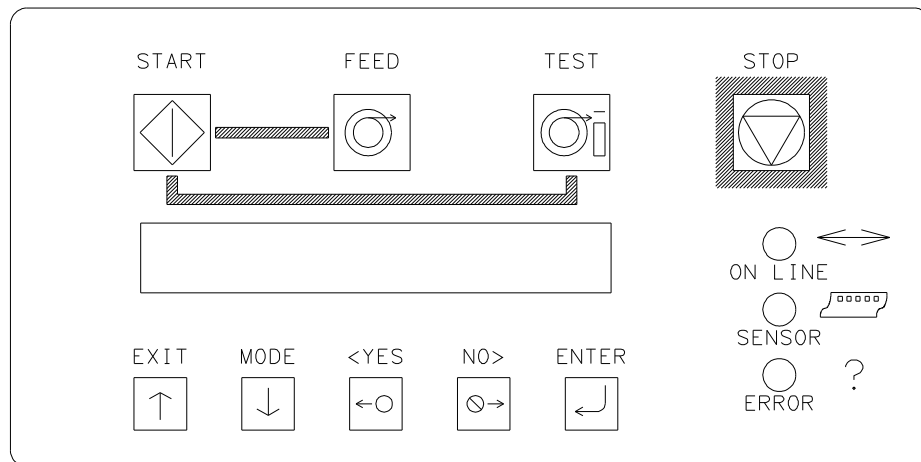

Printer Controls

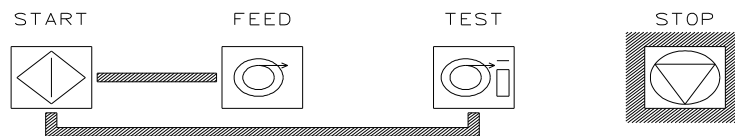

Start

- Starts the printer
- ON LINE light must be GREEN
(Batches downloaded to be printed)

Feed

- FEED and START must both be used
- Feed will stop when the buttons are released
- Labels between print station one and the knife will be cut and stacked as finished labels
- Stock moves through in one continuous strip
- Stock moves through without printing
- Ink will advance, ink save on print station two will automatically be activated.
- The print heads must be latched in the down position.

Test

- TEST and START must both be used
- Test will stop when the buttons are released
- Labels between print station one and the knife will be cut and stacked as finished labels
- Stock moves through in one continuous strip
- Stock moves through with test pattern printing
- The ink will advance with the stock.
- The print heads must be latched in the down position.

Stop

- The stop button will stop the printer at the end of the current label being printed.

Indicator Lights

The AVERY DENNISON 676 has three Indicator lights. These lights are used along with the LCD display to tell the operator the current status of the printer.

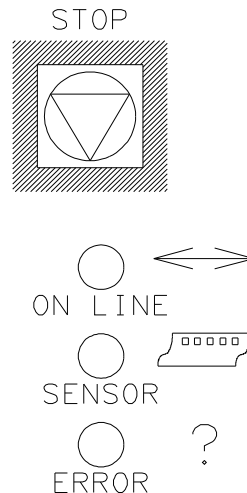

On Line

OFF

- Has not been powered on.
- Is in its power - up sequence.
- Failed the system test

After Power Up Sequence:

- Printer is running.

ORANGE

- System is operational
- Ready for batches to be downloaded

GREEN

- Batches to print, ready to start

Sensor

GREEN = "C" SENSOR

- Printer is stopped, - light is on, - sensor is positioned over a web sensor mark
- Flashing light while the printer is running, - the sensor is in-line with the registration HOLES

ORANGE = REFLECTIVE SENSOR

- Flashing light while the printer is running, - the sensor is in-line with the registration PRINTED MARKS

Error

ORANGE

- System inter-lock triggered, display for error LCD Display

The LCD display is a 2 line, 24 character, with back lighting feature for easy readability. The first line of the display, in most cases, will be a prompt or question - the second line is the response.

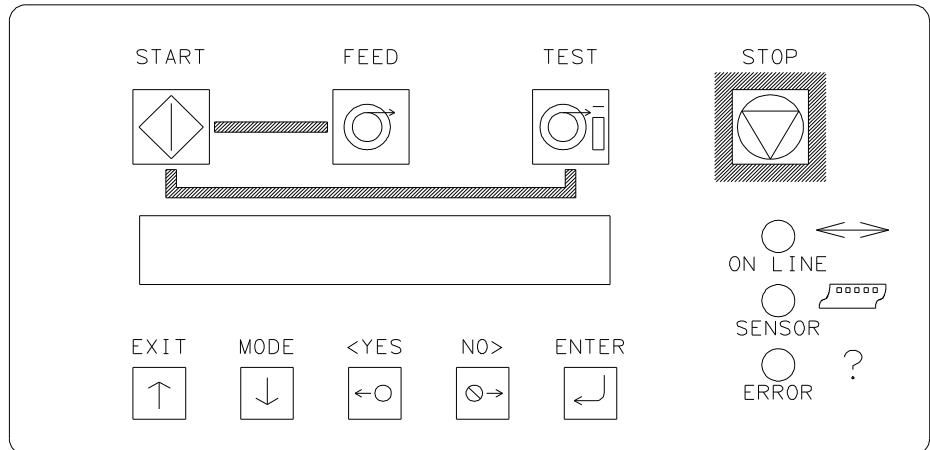

Display Modes

There are four (4) main mode levels that are selected and modified using the following function keys:

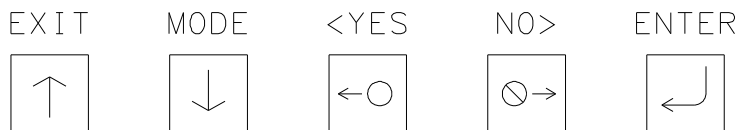

Use the MODE ↓ key to move through the main mode screens shown below:

Pressing the EXIT / Up arrow button will put the user at one of these two screens.

HOME SCREEN

R	E	A	D	Y		F	O	R		B	A	T	C	H	E	S							
6	7	6	/	3	0	0	/			L	O	K	P	R	I	N	T		I	I			

OR

B	A	T	C	H		I	D											Q	U	A	N	T	I	T	Y	
P	C	L	0	0	1																				1	0

Press the MODE / Down arrow button will cycle the panel through the following main screens.

PRINTER ADJUSTMENTS

P	R	E	S	S		E	N	T	E	R		F	O	R												
P	R	I	N	T	/	C	U	T		P	O	S	I	T	I	O	N	S								

PRINTHEAD ADJUSTMENTS

P	R	E	S	S		E	N	T	E	R		F	O	R											
P	R	I	N	T		H	E	A	D		S	E	T	U	P										

CALIBRATE SENSORS

P	R	E	S	S		E	N	T	E	R		F	O	R											
C	A	L	I	B	R	A	T	I	N	G		S	E	N	S	O	R	S							

LIFE COUNTS / VERSIONS

P	R	E	S	S		E	N	T	E	R		F	O	R											
L	I	F	E		C	O	U	N	T	S	/	V	E	R	S	I	O	N	S						

PRINT / CUT POSITIONS

P	R	E	S	S		E	N	T	E	R		F	O	R									
P	R	I	N	T	/	C	U	T		P	O	S	I	T	I	O	N	S					

This screen follows the Batch ID / Batch Qty screen if there are batches to print, otherwise it follows the "Ready for batches" / Model DPI "HOME" screen.

Pressing ENTER will take the user to the PRINTER ADJUSTMENTS screens.

Pressing the MODE / Down Arrow key will take the user to the "PRINTHEAD SETUP" screen.

Pressing the EXIT / Up Arrow key will take the user back to the "HOME" screen.

PRINTER ADJUSTMENTS

P	R	E	S	S		E	N	T	E	R		T	O									
P	R	I	N	T		C	H	E	C	K	O	U	T		F	O	R	M	A	T		

This screen is the first screen under PRINTER ADJUSTMENTS. Pressing ENTER will cause the printer to print the checkout format. The printer will setup to do the checkout format and start printing. The front panel will remain on this screen so the user can use the MODE / Down Arrow key to get to the printer adjustments. When the EXIT / Up Arrow key is pressed the printer stops printing the checkout format and goes back to what it was doing before the checkout was requested.

Pressing the MODE / Down Arrow key will take the user to the first screen of this group. Pressing the EXIT / Up Arrow key will take the user back to the "HOME" screen.

P	R	I	N	T		P	O	S	I	T	I	O	N		S	T	A	T	I	O	N	1
V	A	L	U	E	:	±	X	X		N	E	W		V	A	L	U	E	:	±	Y	Y

Station 1 not used.

P	R	I	N	T		P	O	S	I	T	I	O	N		S	T	A	T	I	O	N	2
V	A	L	U	E	:	±	X	X		N	E	W		V	A	L	U	E	:	±	Y	Y

This screen follows the first screen under PRINTER ADJUSTMENTS. This screen allows the print position of station 2 to be adjusted.

The <YES / NO> buttons are used to change the print value.

The value is displayed in a positive / negative format. The value ranges for XX and YY can be from a -9 to a +9

Pressing the MODE / Down Arrow key will take the user to the next screen.

Pressing the EXIT / Up Arrow key will take the user back to the HOME .

P	R	I	N	T		P	O	S	I	T	I	O	N		S	T	A	T	I	O	N		3
V	A	L	U	E	:	±	X	X			N	E	W		V	A	L	U	E	:	±	Y	Y

This screen follows the second screen under PRINTER ADJUSTMENTS. This screen allows the print position of station 3 to be adjusted.

The <YES / NO> buttons are used to change the print value.

The value is displayed in a positive / negative format. The value ranges for XX and YY can be from a -9 to a +9

Pressing the MODE / Down Arrow key will take the user to the next screen.

Pressing the EXIT / Up Arrow key will take the user back to the HOME .

S	T	A	T	I	O	N		2		D	O	T		S	H	I	F	T					
V	A	L	U	E	:	±	X	X			N	E	W		V	A	L	U	E	:	±	Y	Y

This screen follows the CHANGE CUT POSITION screen. This screen allows the print position of station 2 to be adjusted in the WEB direction.

The <YES / NO> buttons are used to change the shift value.

The value is displayed in a positive / negative format. The value ranges for XX and YY can be from a -16 to a +16 dots. (One dot is 1/300")

Pressing the MODE / Down Arrow key will take the user to the first screen under PRINTER ADJUSTMENTS.

Pressing the EXIT / Up Arrow key will take the user back to the HOME.

PRINTHEAD SETUP

P	R	E	S	S		E	N	T	E	R		F	O	R								
P	R	I	N	T	H	E	A	D		S	E	T	U	P								

This screen follows the PRINT POSITIONS screen.

Pressing ENTER will take the user to the PRINTHEAD SETUP screens.

Pressing the MODE / Down Arrow key will take the user to the "LIFE COUNTS / VERSIONS" screen.

Pressing the EXIT / Up Arrow key will take the user back to the "HOME" screen.

C	H	A	N	G	E		S	T	R	O	B	E		S	T	A	T	I	O	N		2	
V	A	L	U	E	:	±	X	X			N	E	W		V	A	L	U	E	:	±	Y	Y

This screen follows strobe adjust for station 1. This screen allows the user to adjust the strobe for station 2. The <YES / NO> buttons are used to change the print value. The value is displayed in a positive / negative format. The value ranges for X and Y can be from a -7 to a +7. Pressing ENTER will change the CURRENT STROBE value to the NEW STROBE value.

Pressing the MODE / Down Arrow key will take the user to the next screen. Pressing the EXIT / Up Arrow key will take the user back to the HOME screen.

C	H	A	N	G	E		S	T	R	O	B	E		S	T	A	T	I	O	N		3	
V	A	L	U	E	:	±	X	X			N	E	W		V	A	L	U	E	:	±	Y	Y

This screen follows strobe adjust for station 2. This screen allows the user to adjust the strobe for station 3. The <YES / NO> buttons are used to change the print value. The value is displayed in a positive / negative format. The value ranges for X and Y can be from a -7 to a +7. Pressing ENTER will change the CURRENT STROBE value to the NEW STROBE value.

Pressing the MODE / Down Arrow key will take the user to the next screen.

Pressing the EXIT / Up Arrow key will take the user back to the HOME screen.

H	E	A	D		C	A	T	E	G	O	R	Y		S	T	A	T	I	O	N		2	
V	A	L	U	E	:	±	X	X			N	E	W		V	A	L	U	E	:	±	Y	Y

This screen follows HEAD CATEGORY STATION 1. The screen allows the user to enter the head category for station 2. The <YES / NO> buttons are used to change the head category value. The value ranges from 1 to 8. Pressing ENTER will change the head category value to the new value. See the section “PRINTHEAD REPLACEMENT” for instructions on setting the head category.

Pressing the MODE / Down Arrow key will take the user to the next screen.

Pressing the EXIT / Up Arrow key will take the user back to the HOME screen.

H	E	A	D		C	A	T	E	G	O	R	Y		S	T	A	T	I	O	N		3	
V	A	L	U	E	:	±	X	X			N	E	W		V	A	L	U	E	:	±	Y	Y

This screen follows HEAD CATEGORY STATION 2. The screen allows the user to enter the head category for station 3. The <YES / NO> buttons are used to change the head category value. The value ranges from 1 to 8. Pressing ENTER will change the head category value to the new value. See the section “PRINTHEAD REPLACEMENT” for instructions on setting the head category.

Pressing the MODE / Down Arrow key will take the user to the next screen.

Pressing the EXIT / Up Arrow key will take the user back to the HOME screen.

S	T	A	T	I	O	N		A	C	T	I	V	A	T	I	O	N				2	3	
C	L	O	S	E		H	E	A	D	S		P	R	E	S	S		E	N	T	E	R	

This screen follows HEAD CATEGORY STATION3. The screen allows the user to configure the printer for the number of heads in the system. The numbers '2', '3' stand for stations 2 and 3. If the number appears on the screen then it means that station is activated. If the number doesn't appear on the screen then that station is not activated and the printer will not print, look for ink out, or look for head open on that print station.

The printer determines if a head is in the system by checking the head open switch when the 'Enter' button is pressed. If the user would like to disable a station that is

D	E	F	A	U	L	T		T	R	A	N	S	F	E	R		T	Y	P	E	1		
V	A	L	U	E	:	X	X	X			N	E	W		V	A	L	U	E	:	Y	Y	Y

Station 1 not used.

D	E	F	A	U	L	T		T	R	A	N	S	F	E	R		T	Y	P	E	2		
V	A	L	U	E	:	X	X	X			N	E	W		V	A	L	U	E	:	Y	Y	Y

This screen follows the DEFAULT TRANSFER TYPE1 screen IF emulation mode is something other than none. This screen allows the DEFAULT TRANSFER TYPE to be changed. This transfer type is used when the printer is in 630 or 650 emulation mode for print station 2. The 630 and 650 do not send valid 676 transfer types in their PCL code. This default is used for those formats. Use the <YES and NO> keys change the number value at the cursor position. Pressing ENTER will update the current position with the selection and move the cursor to the next position. All three positions must be entered. (I.e. 053 for type 53). After ENTER is pressed on the last digit the TRANSFER TYPE on the top line will be updated. Pressing the MODE / Down Arrow key will take the user to the next screen. Pressing the EXIT / Up Arrow key will take the user back to the "HOME" screen.

D	E	F	A	U	L	T		T	R	A	N	S	F	E	R		T	Y	P	E	3		
V	A	L	U	E	:	X	X	X			N	E	W		V	A	L	U	E	:	Y	Y	Y

This screen follows the DEFAULT TRANSFER TYPE2 screen IF emulation mode is something other than none. This screen allows the DEFAULT TRANSFER TYPE to be changed. This transfer type is used when the printer is in 630 or 650 emulation mode for print station 3. The 630 and 650 do not send valid 676 transfer types in their PCL code. This default is used for those formats. Use the <YES and NO> keys change the number value at the cursor position. Pressing ENTER will update the current position with the selection and move the cursor to the next position. All three positions must be entered. (I.e. 053 for type 53). After ENTER is pressed on the last digit the TRANSFER TYPE on the top line will be updated. Pressing the MODE / Down Arrow key will take the user to the next screen. Pressing the EXIT / Up Arrow key will take the user back to the "HOME" screen.

				L	A	N	G	U	A	G	E	:	X	X	X	X	X	X					
N	E	W		L	A	N	G	U	A	G	E	:	Y	Y	Y	Y	Y	Y					

This screen follows the "DEFAULT TRANSFER TYPE" screen. This screen allows the front panel display language to be changed. Use the <YES and NO> keys to move between the supported languages on the printer. Any number of front panel languages can be stored on the Flash Disk Module (dependent on available space). If no additional languages other than the default are available on the printer XXXXXX and YYYYYY will be the same value. Pressing ENTER will update the display language with the selection. Pressing the MODE / Down Arrow key will take the user to the "PROTOCOL" screen. Pressing the EXIT / Up Arrow key will take the user back to the "HOME" screen.

Warning: Mis-matched communication protocols may result in the inability to communicate with the printer and / or loss of data.

				P	R	O	T	O	C	O	L	:	X	X	X	X	X	X				
N	E	W		P	R	O	T	O	C	O	L	:	Y	Y	Y	Y	Y	Y				

This screen follows the LANGUAGE screen. This screen allows the communications protocol to be changed between the supported types. Use the <YES and NO> keys to move between the supported protocols – RTS / CTS is considered hardware handshaking and XON / XOFF is considered to be software. Pressing ENTER will update the communications protocol with the selection. Pressing the MODE / Down Arrow key will take the user to the next screen. Pressing the EXIT / Up Arrow key will take the user back to the "HOME" screen.

				B	A	U	D		R	A	T	E	:	X	X	X	X	X	X				
N	E	W		B	A	U	D		R	A	T	E	:	Y	Y	Y	Y	Y	Y				

This screen follows the PROTOCOL screen. This screen allows the serial communications speed to be changed. Use the <YES and NO> keys to move between the supported speeds – typical is 9600 dependent on serial communication cable length. Pressing ENTER will update the communications speed with the selection. Pressing the MODE / Down Arrow key will take the user to the "CHANGE DATE AND TIME" screen. Pressing the EXIT / Up Arrow key will take the user back to the "HOME" screen.

C	H	A	N	G	E		D	A	T	E		A	N	D		T	I	M	E				
0	3	/	1	4	/	0	0		1	2	:	0	5		P	M							

This screen follows the "BAUD RATE" screen. This screen allows the system date and time to be changed. When this screen appears, the first digit of the month will be blinking. (The date is shown in US format, MM/DD/YY.) Pressing the <YES and NO> keys will change the digit up and down respectively. Pressing ENTER will move to the next digit. Only the digits and the A or P in AM or PM can be changed. When all changes are complete, pressing the MODE / Down Arrow key will take the user to the "INKSAVE ENABLE / DISABLE" screen, and pressing the EXIT / Up Arrow key will take the user back to the "HOME" screen. If an illegal date or time is entered, this screen will be re-displayed with the original date or time. A valid date and time must be entered before the user can go on.

Adjustments

Feed Roller Pressure

General

The rubber pressure roller is supported by an eccentric shaft mounted in bearings located in vertical slots in the front and rear mounting plates of the drive module. This roller is mounted in an extension spring controlled arm so no pressure adjustment is required.

Sensors

Sensor Identification:

Stock Out

A micro switch located on the back of the unwind will detect when the stock core is lifted when the stock is consumed and stop the printer. AVERY DENNISON stocks are fastened to the supply core and will lift the core at the end of the roll. Supplies that do not have this feature will fail to stop the printer.

Ink Out

Optical sensors located on each print station's ink unwind arbor allow the printer to monitor the availability of ink.

Feed Open

A micro switch on the back of the feed module will detect the position of the feed module pressure knob and only allow the printer to operate with the feed pressure knob closed.

Sensor Adjustments:

All the micro switches and optical sensors in your 676 LKP printer were calibrated at the time your printer was manufactured, however from time to time it may become necessary to readjust / recalibrate due to the large variety of stocks and inks that can be run on the machine.

Stock Out

With a full roll of stock loaded on the unwind with the unwind web guides properly adjusted you should hear the switch click as you raise and lower the roll. If not the switch bail is adjusted by carefully bending it as needed.

Feed Open

If the switch is in need of adjustment - first check and adjust as needed the feed pressure as it will affect the switch adjustment. With the machine rear cover removed while opening and closing the feed pressure knob you should hear the switch clicking. If not, the switch bail is adjusted by carefully bending it as needed.

Machine Set Up Sequence

- 1) Power off the printer, remove the media and ink and thoroughly clean it from the unwind to the stock exit using alcohol and a clean soft cloth. The print heads should be cleaned as per the Print Head Cleaning instruction section in the manual.
- 2) Load a full roll of an average width media and ink on the printer.
- 3) Power on the printer. After passing diagnostics tests the front panel should display READY FOR BATCHES if not then resolve any remaining error conditions.
- 4) Arrow down to the PRINT / CUT POSITIONS mode and press enter. Cycle through all the prints, cut, and station two dot shift values to get a feel for their present settings.
- 5) Cycle back to the beginning of the Printer Adjustment and press enter at Print Checkout Format.
- 6) If all three print stations or stations two and three are present, adjust station number two by moving the dots with the dot shift on the front panel so that the tracking line on the front of the label becomes one continuous line.

The machine is now ready for production formats at which time the operator should need only to fine-tune the prints and strobes via the front panel.

Maintenance

Cleaning

Print Head Cleaning

CAUTION: TURN OFF THE POWER TO THE PRINTER BEFORE STARTING ANY CLEANING.

NEVER REMOVE THE HEAD FROM THE PRINTER EXCEPT FOR REPLACEMENT.

The Anti-static wrist strap (which must contact the skin and be tight) and anti-static gloves must be worn at all times when handling a print head to avoid damaging the print head.

Supplies:

- Always use clean supplies when cleaning the head.
- Never use anything abrasive to the head.
- NEVER use anything metallic on or near the printhead.
- Alcohol and a cotton swab are the recommended items to use when cleaning the printhead.

RECOMMEND AVERY DENNISON "MASTER CLEANING KIT" # 921338

Procedure:

- The Printhead should be cleaned every two to four hours of continuous usage. A good cleaning of the print head after eight to twelve hours of continuous usage should be done. This cleaning must be done with the print head in the printer.
- Apply a liberal amount of alcohol to a swab.
- Rub the swab across the print line of the printhead to remove the build-up.
- The platen roller and feed rollers should also be cleaned with alcohol to remove ink and card dust build-up.

Clean Platen Roller

You may determine if the printhead has been adjusted properly by performing a test pattern as documented elsewhere in this manual. A properly adjusted print head will produce an even grid of chevrons when the test pattern is performed. **Before making any judgments as to the quality of the printhead, it is absolutely necessary to ensure that the platen roller and the printhead are clean of all debris.** Clean the platen roller located immediately beneath the print head with a clean cloth and a small amount of alcohol. Be careful not to damage the platen roller while cleaning. If the roller is worn, replace the roller.

Supplies:

- Always use clean supplies when cleaning the sensor and light bar.
- Never use anything abrasive to the sensor and light bar.
- NEVER use an alcohol-based solution when cleaning the sensor or light bar.
- Dry air or a cotton swab are the AVERY DENNISON recommended items to use when cleaning the sensor and light bar.

Print Head Handling

Warning

Print heads can be damaged easily, and are subject to premature failure if not cleaned on a regular basis. Please follow the procedures carefully to help ensure print head life and print quality.

Thermal print heads are very sensitive and must be handled with care to help ensure longer print head life. Because print heads may be damaged through a number of ways, AVERY DENNISON has developed the following procedures;

Handling

Static discharge is very detrimental to thermal print heads. To avoid contacting print heads with a static charge, follow these simple procedures:

- All print heads should be kept in original anti-static bags until they are placed in the machine.
- The 676 LKP printer is supplied with an anti-static wrist strap. Locate the strap - it must be worn at all times when handling the print heads.
- Do not touch any terminals extending from the print head or the print line.
- Anti-static gloves are provided with your machine upon installation and extras may be ordered from AVERY DENNISON. These gloves must be worn at all times when handling the print head. If an anti-static glove is not available, make absolutely certain to thoroughly wash and dry your hands before handling the print head. Oils from your hands can contaminate the print line and quickly destroy the printing elements.

Print Head Replacement

NEVER REMOVE THE PRINT HEAD FROM THE PRINTER EXCEPT FOR REPLACEMENT.

TURN OFF THE POWER TO THE PRINTER BEFORE STARTING ANY ELECTRONIC COMPONENT REPLACEMENT.

NOTE: The Anti-static wrist strap (which must contact the skin and be tight) and anti-static gloves must be worn at all times when handling a print head to avoid damaging the print head.

- 1) Review the Printhead Handling Procedure Sheet packaged with each print head to determine if any procedures have changed before beginning this procedure.
- 2) Remove the media and ink from the machine for easy print head removal.
- 3) Unplug the cables that connect to the print head. Unplug the cable by firmly, but gently pulling it out.
- 4) Loosen (2) 6-32 Phillips screws visible through holes in the upper print head holder. Slide the head toward unwind end of printer.

NOTE: Screws are fitted with washers.

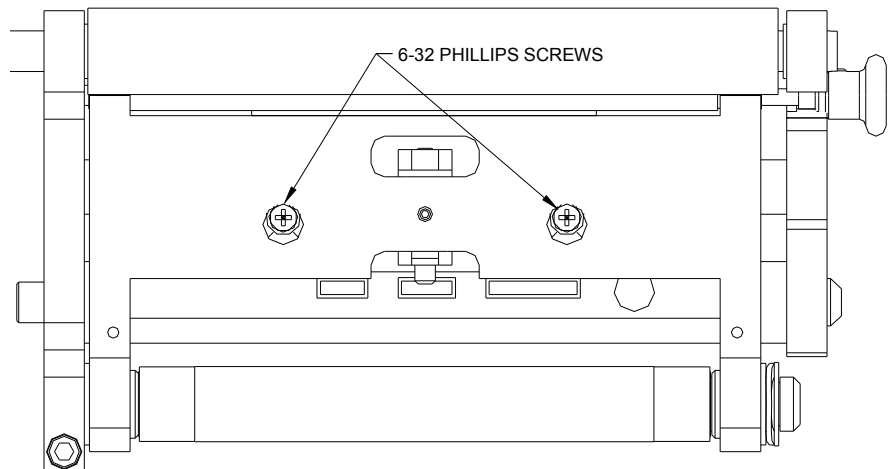

- 5) Place your hand (with static gloves on) underneath the print line of the print head and pull down guiding screws through keyhole slots. This will remove the print head assembly from the mount plate. You may need to "help" the print head out by pushing on the heat sink with your left hand.
- 6) Remove the two print head mount screws located on the top of the print head with a Phillips head screwdriver.

7) Remove the old printhead carefully from the heat sink.

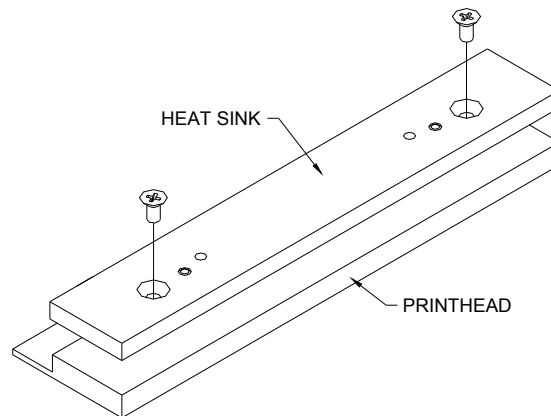

8) Place the new print head onto the heat sink.

9) Replace the two print head mount screws. Be sure that the head is resting flat on the heat sink before tightening these screws.

10) Replace the print head assembly in the printer, sliding screw / washer (Paragraph 4) into the holes in the mount plate. Make sure that the screw / washer slides all the way to the front of the holder. Tighten screws.

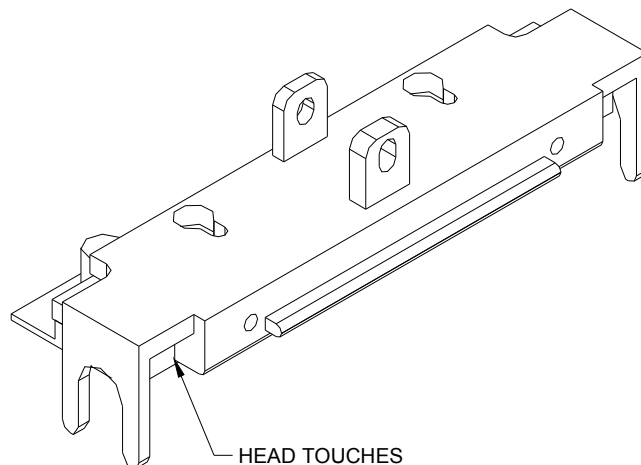

11) Reconnect the print head cable connectors, making sure that the connectors are seated tightly.

NOTE: If the cable is not connected correctly, the print head will be destroyed when the machine is powered on. Check to see that the cable is tight by observing from underneath the print head. The cable's connectors should be inside of the connectors located on the print head.

12) Replace the media and ink and double-check your work. Power the machine on and make sure that no adverse effects are noted. **Before printing - the printhead category must be set to match the new printheads mean resistance as labeled on the head itself.**

A) On the front panel arrow down to PRINT HEAD SETUP using the MODE button and press ENTER.

B) Arrow down to HEAD CATEGORY for the print station you replaced the head in.

C) Using the left (<YES) or right (NO>) arrow key set the HEAD CATEGORY as called out in the PRINthead CATEGORY CHART below.

D) Press the ENTER key to enter the value. The printer must be turned off and back on for the change to take effect.

PRINthead CATEGORY CHART

MEAN RESISTANCE obtained from printhead label	PRINthead CATEGORY entered in front panel for print station containing head
1190 – 1243	1
1244 - 1295	2
1296 – 1348	3
1349 - 1400	4
1401 – 1453	5
1454 - 1505	6
1506 – 1558	7
1559 – 1610	8

13) As a final test of the print head installation, run a test pattern to check the print quality. You should observe an even grid of chevrons. If you do not see such a grid, make sure both the front and the back printheads are moved all the way to the right.

Lubrication Procedure

General

The 676 series printers are factory equipped with either composition bearings not requiring lubrication, pre-lubricated bronze bearings, or pre-lubricated needle bearings. Periodic cleaning of the printer and removal of dust will greatly enhance the length of the time the printer will function.

Composition (Iglide) Bearings

- 1) If field replacement of an assembly fitted with a plastic bearing is performed, a single drop of spindle oil should be applied to assist in bearing break-in.
- 2) If, after long use, a plastic bearing starts to "squeak", disassemble the component containing the bearing and lightly abrade the shaft surface. Clean the bearing (dust or old oil) with alcohol, re-lubricate with 1 drop of light oil and reassemble.

No other printer lubrication should be required in normal use.

Electrical Trouble Shooting

Power Up / Sign On / Communications

Problem	Probable Cause	Corrective Action
Machine fails to power up with no light present in the AC power switch.	1) Incorrect power voltage.	1) Confirm that the AC entry is configured for the line voltage intended to be applied to the machine. Failure to do so can damage the machine's internal power supply. Refer to the "Fuse Configuration".
	2) Lack of power to machine.	2) Check that both ends of the power cord are plugged in securely. 2A) Confirm that the outlet the machine is plugged into has power.
	3) Missing or blown fuse(s)	3) Check that the fuse(s) located inside the AC entry are present and intact. Replace as needed. Refer to the "Fuse Configuration".
Machine fails to power up with light present in the AC power switch.	1) Unconnected cable / connector inside machine.	1) Power off and remove the power cord from the AC entry. Remove the back cover and inspect the cables and connectors to and from the power supply. Refer to the "Electrical System Schematic".
	2) Thermal Control Board unplugged from the Mother Board	2) Power off and remove the power cord from the AC entry. Remove the back cover and reseal the Thermal Control Board.
Front panel displays no text or nothing at all.	1) Front panel cable unplugged.	1) Power off and remove the power cord from the AC entry. Remove the back cover and inspect the cable and connectors to and from the front panel. Refer to the "Electrical System Schematic".

Problem	Probable Cause	Corrective Action
Front panel does not complete diagnostics test 2.	1) One or more PC board(s) unplugged from the Mother Board.	1) Power off and remove the power cord from the AC entry. Remove the back cover and reseal the offending board.
Machine does not receive batches.	1) Serial communications cable loose or unconnected.	1) Check and secure both ends of the serial cable with the thumbscrews.
	2) Machine not powered on or has not completed diagnostics tests.	2) Power machine on and wait until machine displays "Ready for batches". Re-download data.
	3) Data sent to wrong printer.	3) In PCMate change to the printer the data is intended to be sent.
	4) Configuration incorrect in PCMate.	4) Re configure PCMate for AVERY DENNISON PCL printer as per your PCMate manual.
	5) Faulty Thermal Control Board.	5) Replace Thermal Control Board.
	6) Jumpers not configured correctly.	6) Contact AVERY DENNISON Service.

Stock / Ink Advance

Problem	Probable Cause	Corrective Action
Stock does not advance when the start button is depressed.	1) No batches to be printed.	1) Download batch (if batch downloaded uses the same format as a previously downloaded batch the machine with start automatically).
	2) An interlock condition exists.	2) Determine the number and type of interlock(s) by reading the front panel display. As each is corrected the number of errors will decrease (Example "Error 901 Stock Out" reload stock).
	3) Feed motor unplugged or faulty.	3) Check feed motor cable and or replace feed motor.
	4) Thermal Control Board unplugged or faulty.	4) Check Thermal Control Board / AT board connection and or replace Thermal Control Board.
	5) Feed roller not gripping stock.	5) Adjust the feed pressure. Refer to "Mechanical Adjustment Of Feed Roller Pressure".
	6) Feed rollers bound.	6) With power off check that all rollers turn freely.
	7) Stock bound.	7) With the print head and feed open check that the stock will pull through the printer with little to no resistance.
Ink does not advance when the start button is depressed.	1) No batches to be printed.	1) Download batch (if batch downloaded uses the same format as a previously downloaded batch the machine with start automatically).
	2) An interlock condition exists.	2) Determine the number and type of interlock(s) by reading the front panel display. As each is corrected the number of errors will decrease (Example "Error 901 Stock Out" reload stock).
	3) Ink motor unplugged or faulty.	3) Check ink motor cable and or replace ink motor.
	4) Thermal Control Board unplugged or faulty.	4) Check Thermal Control Board / AT board connection and or replace Thermal Control Board.
	5) Ink roller bound.	5) With power off check that all rollers and arbors turn freely.
	6) Ink bound.	6) With the print head open check that the ink will pull through the printer with little to no resistance.

Print

Problem	Probable Cause	Corrective Action
Machine advances stock but does not print.	1) Print head cable unconnected or faulty.	1) Power off the machine and reinsert the offending connector or replace cable.
	2) Print head faulty.	2) Replace print head.
	3) Head Driver Board unplugged or faulty.	3) Check Head Driver Board / AT board connection and or replace Head Driver Board.
Print registration is off in the feed direction.	1) Print position is incorrect.	1) Enter the setup menu and readjust the print setting as needed.
	2) Field(s) position incorrect in the format.	2) Using formatter - check and readjust the field(s) position(s) as needed.
	3) Bound platen roller.	3) Check that the platen roller turns freely on it's shaft. If it does not replace it.
Print registration is off in the web direction.	1) Machine incorrectly threaded.	1) Check and rethread the media as needed. Refer to "Loading Stock".
	2) Web guides incorrectly adjusted.	2) Check and adjust as needed. Refer to "Web Guide Adjustment".
	3) Unwind incorrectly adjusted.	3) Check and adjust as needed. Refer to "Web Guide Adjustment".
	4) Incorrect DIP switch settings on the Thermal Control Board.	4) Check and reset DIP switches as needed. Refer to "TCB Dip Switch S2 Settings".
Print contrast is too light or dark.	1) Incorrect strobe setting selected in the format.	1) Using Formatter - check and adjust the strobe setting according to the media and ink being used.
	2) Incorrect strobe setting in the machine setup.	2) Enter the setup menu and readjust the strobe as needed.
Voids in print image in the feed direction.	1) Ink misaligned with format.	1) Adjust ink position on the arbors to achieve full ink coverage over all fields on the format.
	2) Print head dirty.	2) Power off the machine clean the print head and platen. Refer to "Print Head Cleaning".
	3) Faulty print head.	3) After cleaning head and running the test pattern to confirm that a void still exists. Replace the print head.
	4) Worn platen roller.	6) Replace platen roller.
Machine continually stops with an erroneous interlock condition.	1) Ink Sensor uncalibrated.	1) Recalibrate the sensor from the front panel using the "Calibrate Sensors" mode. Refer to "Optical Sensor Electrical Calibration".
	2) Ink Sensor position misadjusted.	2) Relocate correctly.
	3) Ink sensor type (light / dark) incorrect in the format for the ink type being used.	3) Either change the ink or the ink type in the format.

Mechanical Trouble Shooting

Stock

Problem	Probable Cause	Corrective Action
Stock will not roll or jumps	1) Incorrect adjustment of unwind web guides	1) Be sure stock roll is as flat as possible and does not extend over core.
		2) Adjust web guides to touch stock roll but not pinch the roll.
Machine fails to stop at end of roll.	1) Incorrect adjustment of stock-out sensor.	1) Adjust contact strip so that a “click” will be heard when supply roll is lifted.
Stock does not pull smoothly through printhead module.	1) Web guides on unwind arm too tight.	1) Adjust web guides to touch outer edges of stock with minimum pressure required to keep stock-out switch closed.
	2) Web guides too tight	2) Adjust guides to touch edge of stock.
Stock jams in bridge blade rollers or knife area.	1) Knife mounted bridge blade too close to stationary bridge blade.	1) Loosen screws in upper knife securing bridge blade roller assembly and slide up (holes in blade are slotted) until rollers just contact stock. Tighten screws.

Ink

Problem	Probable Cause	Corrective Action
Ink wrinkles or will not pull smoothly.	1) Ink buildup on turn bar(s).	1) Clean with alcohol.
	2) Incorrect ink width.	2) Use an ink width no wider than stock being printed. This is especially critical when using a narrow web with cut down rollers.
Ink rolls loosely on take-up roller.	1) Take-up roller not turning.	1) Assure roller does not bind and is clean.
	2) Take-up core binding on locator plate.	2) Move core .015" - .030" (.38mm - .76mm) away from plate.
	3) Take-up roller too full.	3) Remove used ink roll. It is designed to hold only 1 full roll.

Print

Problem	Probable Cause	Corrective Action
Poor print - uneven or no print (mechanical). Also see electrical trouble shooting.	1) Broken ink.	1) Replace ink and readjust (see INK trouble shooting).
	2) Ink not rewinding.	2) Readjust (see INK trouble shooting).

Appendix B

Software Upgrade Chip Placement Positions

Thermal Control Board P/N 371105TT

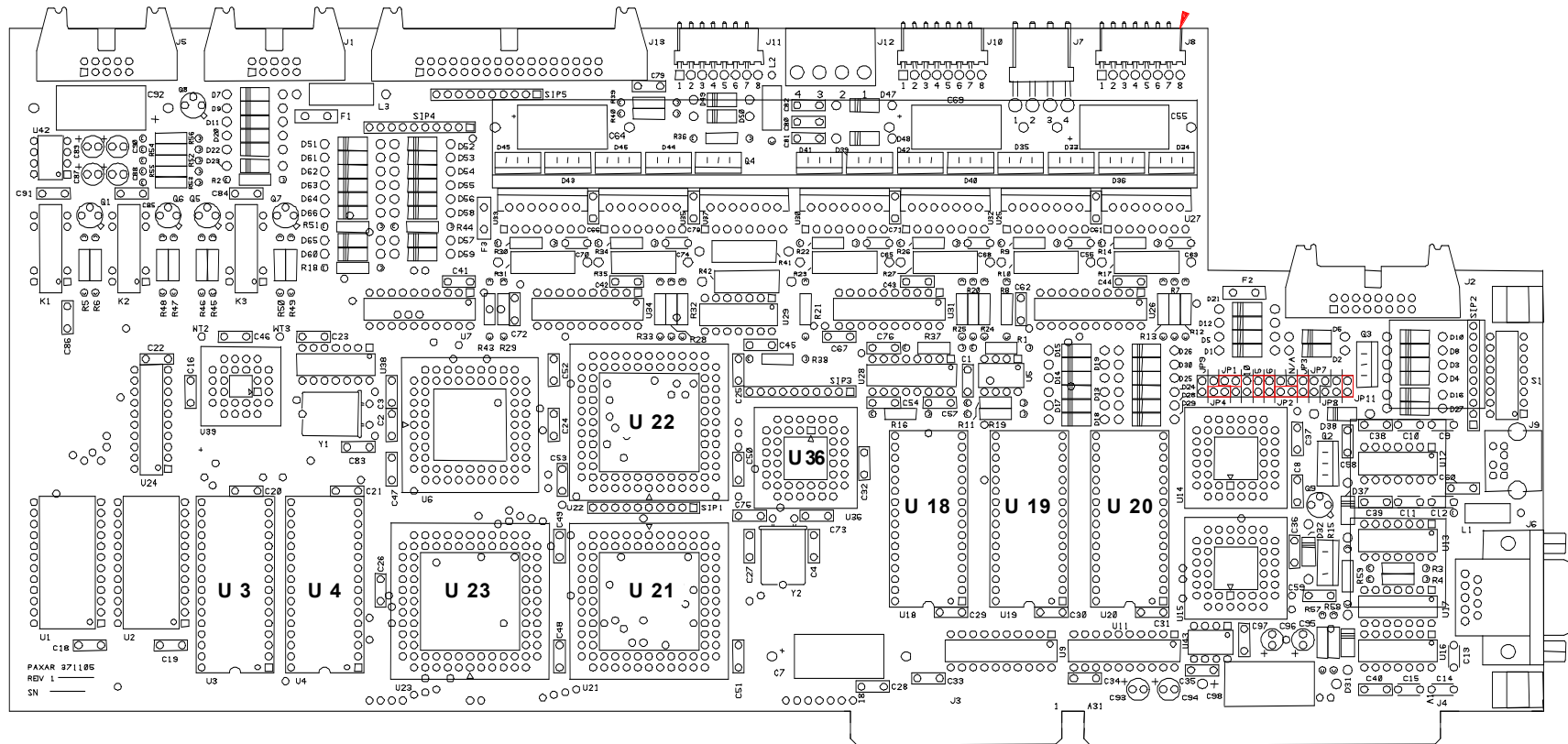

THERMAL CONTROL BOARD

Align angled corners of chip with socket and arrow denotes pin #1 or dimple on chip.

Head Driver Board P/N 371106TT

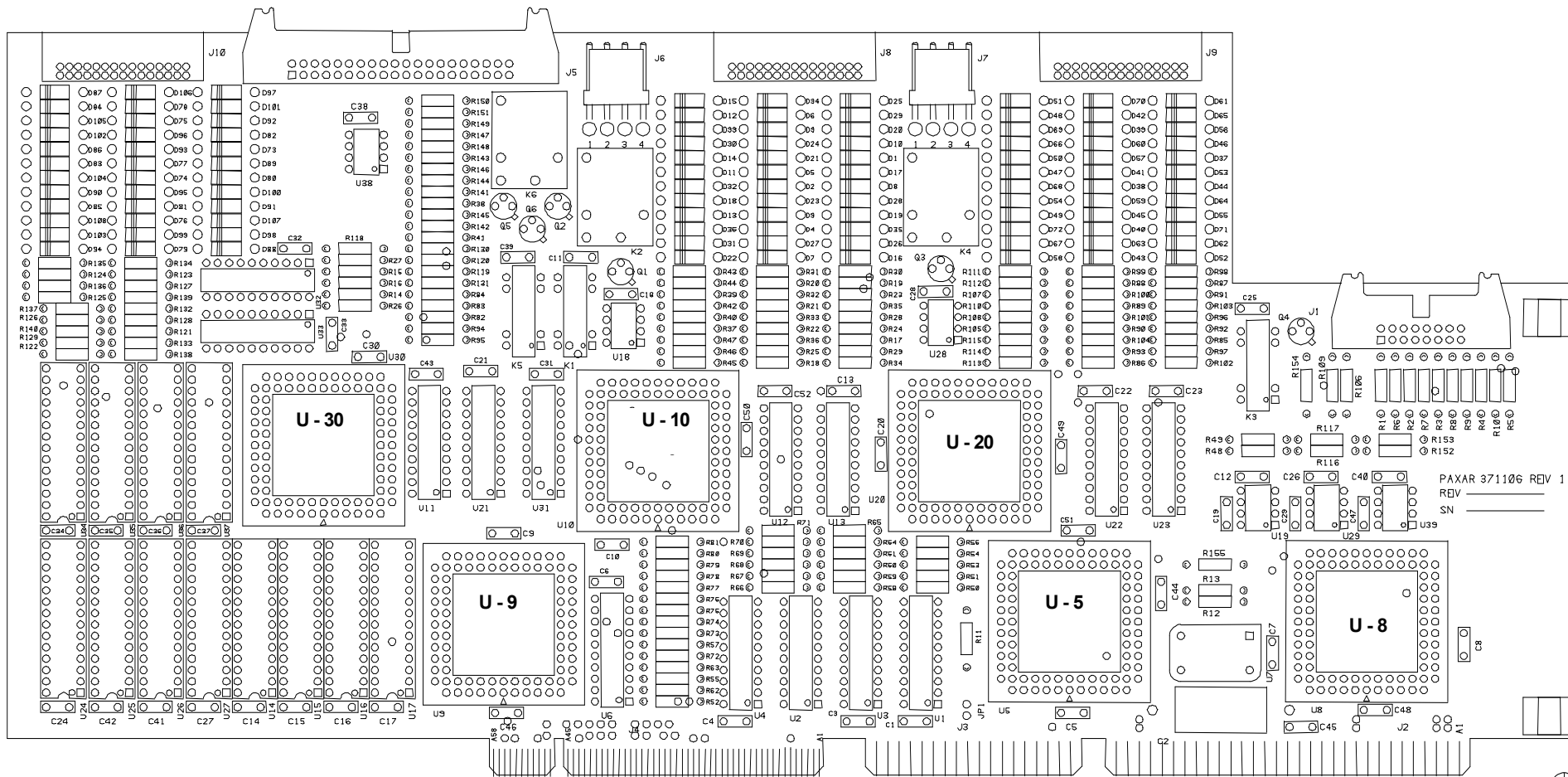

(Use chip removal tool p / n. 351156 for square I.C.'s)

HEAD DRIVER BOARD

Align angled corners of chip with socket and arrow denotes pin #1 or dimple on chip.

Front Panel Board P / N 351108

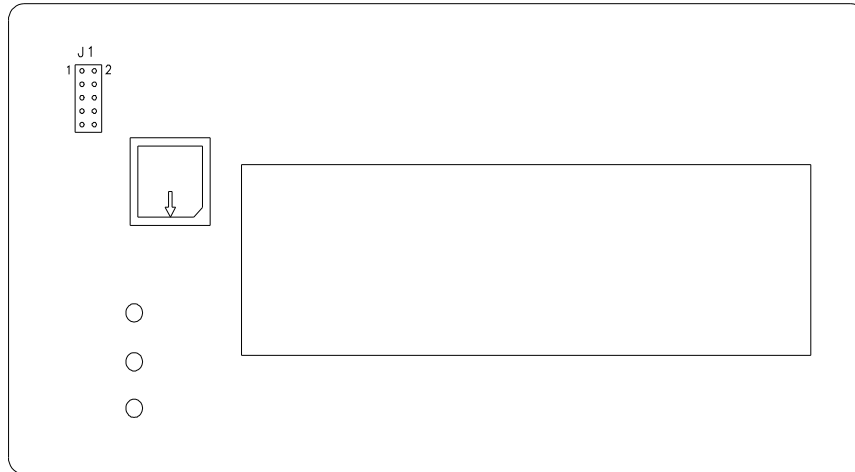

(Use chip removal tool p / n. 351156 for square I.C.'s)

FRONT PANEL BOARD. Upgradeable software I.C.'s include U1.
Align angled corners of chip with socket and arrow denotes pin #1 or dimple on chip.

Front Panel Diagnostic Descriptions

Diagnostic Numbers	Descriptions
1	Front panel initialization
2	TCB Ophys initialization
5	Attempting Serial Host Initialization
6	Initializing Verifier
7	Executing Protected Mode Imaging Code
8	Checking Flash Disk Module
9	Attempting to read in scalable fonts.
10	Initializing Font Scaler
11	Attempting to load code pages
12	Attempting to read in logos
13	Attempting to read in care symbols
14	Waiting for Machine Definition from TCB
15	Attempting to create test pattern
16	Attempting to create strobe tables
17	Attempting to read in formats
18	Protected Mode Imaging Code initialization complete
19	Serial Communications Activated
0	Power up complete

Appendix C

Printhead Life Extension

NOTE: This section was written specifically for the 636 / 656 – but the information is useful and applicable for the 676 series printers.

Matching stock and ink widths

If your customer is running multiple media and multiple widths on their AVERY DENNISON machine, Great! They are taking advantage of one the most compelling features of our printers: multimedia capability. Our printers can also reduce the width of the ink to only that area being printed. However, we run into printhead problems when customers combine both these features.

The edge of the narrower stock not covered by the ink will gouge the printhead and cause dots to be out.

Here, the customer will have much shorter printhead life because of the edge of the narrower, uncovered stock.

WRONG!

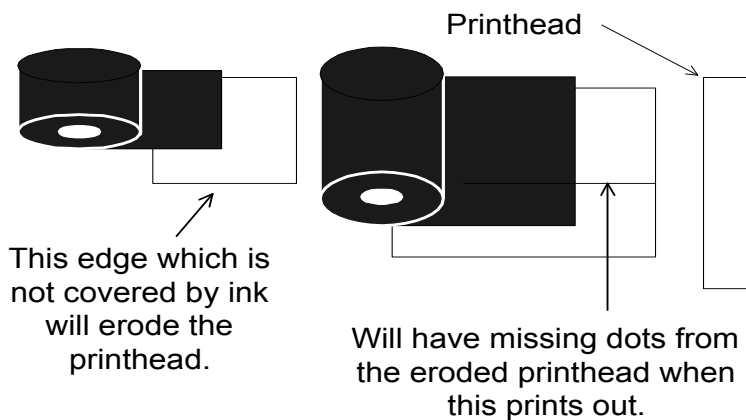

The solution is to make sure that the narrower stocks have at **least 1/8"** of ink coverage over the edge. The widest stock does not need full ink coverage.

RIGHT!

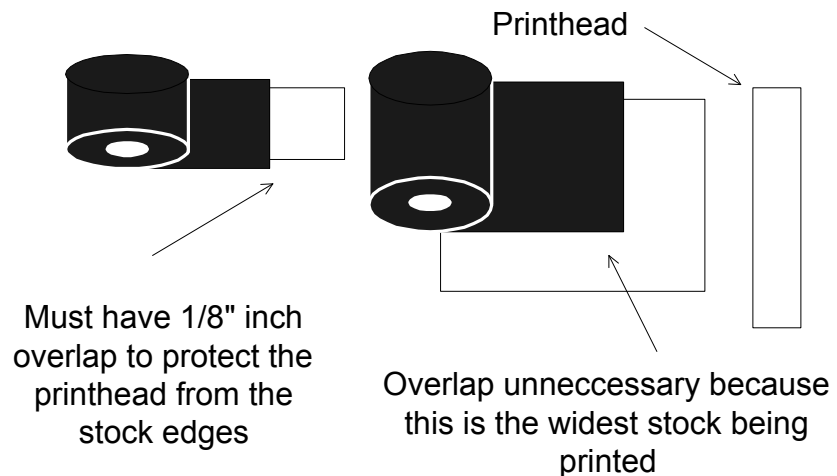

Printhead Fail Modes

Symptoms, Causes, Solutions

Symptom #1: A dot is leaving a line in the print direction. The dot appears to be dragging or failed on, sometimes in the print area, and sometimes not. If in a barcode, the verifier will halt the printer.

Cause: Paper dust or dirt on the printhead causing the ink to print without printhead firing. The dot is NOT failed on. The printhead is DIRTY.

If not addressed immediately: the line will go from black or gray to white and the dot will fail. The printhead will be damaged.

Solution: Immediately stop the printer and clean the printhead in the machine.

If problem continues: Remove the printhead and clean with hard pressure.



Symptom #2: Edges of barcode and text do not appear crisp and sharp.

Cause: Strobe is too high. Printhead is dirty.

Solution: Reduce front panel strobe one increment at a time until fuzzy printing goes away.

If problem continues: Clean the printhead as described below.

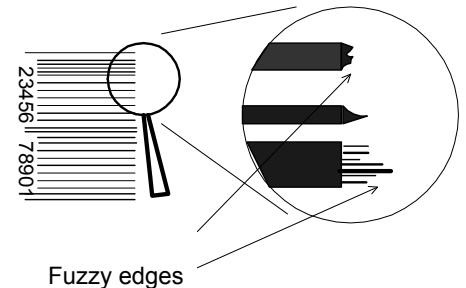

Symptom #3: While printing along fine early in the printhead's life (< 300,000 inches), a dot suddenly appears missing. The verifier will halt the machine if the missing dot is in a barcode.

Cause: Most likely, the printhead failed from static.

Solution: Replace the printhead.

If problem continues: Check that the machine has all the static upgrades. Double check the connections and wires.

Printhead Cleaning Procedure

Printhead performance and life are influenced by proper handling and cleaning.

- Dirt on the printhead that causes problems is often too small to see.
- Exercise care in handling printheads, as they are very susceptible to static. Use the wrist grounding strap and anti-static gloves when handling.
- It is OK to scrub the printhead HARD to clean it. Use rubbing alcohol and the “loop side” or “wool side” of Velcro, followed by drying with rough, brown paper towels.
- If the printhead doesn't work, take it out and clean it again.
- For maximum printhead life, clean the printhead after every roll change of ink or every 20,000 inches.

In Machine Cleaning Procedure

1. Stop the machine after the last batch has printed to avoid losing data.
2. Turn the machine off.
3. Open the printhead carriage assembly.
4. Soak a small amount of rubbing alcohol on a cotton swab and apply to the printhead.
5. Scrub the printhead several times with hard force using the “wool side” of Velcro.
6. Dry the printhead with a dry, brown paper towel.
7. Shut the printhead carriage assembly and resume printing.
8. If a problem continues, remove the printhead and clean it.

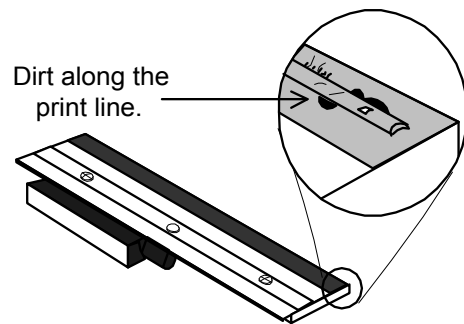

Printhead cleaning when removed from the printer

1. Remove the printhead.
2. Place the printhead upside down on the edge of a clean table with the connector pug over the edge of the table.
3. Soak a small amount of rubbing alcohol a cotton swab and apply to the print line.
4. Scrub the printhead several times using HARD pressure with the “loop side” of Velcro.
5. Dry with a dry, brown paper towel.
6. Replace the printhead.

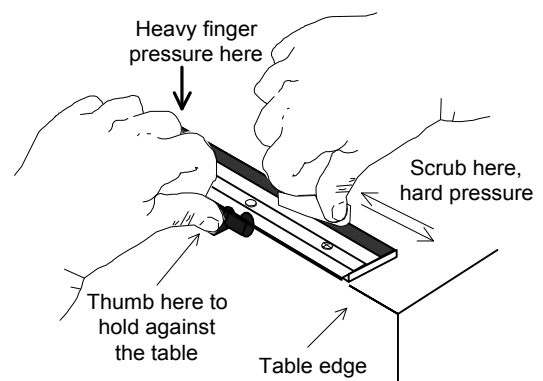

Printhead Installation and Removal Procedures

Printhead removal procedure

1) Loosen (2) 6-32 Phillips screws visible through holes in the upper print head holder. Slide the head toward unwind end of printer.

NOTE: Screws are fitted with washers.

2) Place your hand (with static gloves on) underneath the print line of the print head and pull down guiding screws through keyhole slots. This will remove the print head assembly from the mount plate. You may need to "help" the print head out by pushing on the heat sink with your left hand.

3) Remove the two print head mount screws located on the top of the print head with a Phillips head screwdriver.

4) Remove the old printhead carefully from the heat sink.

Printhead installation procedure

1) Place the new print head onto the heat sink.

2) Replace the two print head mount screws. Be sure that the head is resting flat on the heat sink before tightening these screws.

3) Replace the print head assembly in the printer, sliding screw / washer (Paragraph 1 - Printhead removal procedure) into the holes in the mount plate. Make sure that the screw / washer slides all the way to the front of the holder. Tighten screws.

4) Reconnect the print head cable connectors, making sure that the connectors are seated tightly.

NOTE: If the cable is not connected correctly, the print head will be destroyed when the machine is powered on. Check to see that the cable is tight by observing from underneath the print head. The cable's connectors should be inside of the connectors located on the print head.

Electrical Assembly Drawings

Machine Wiring

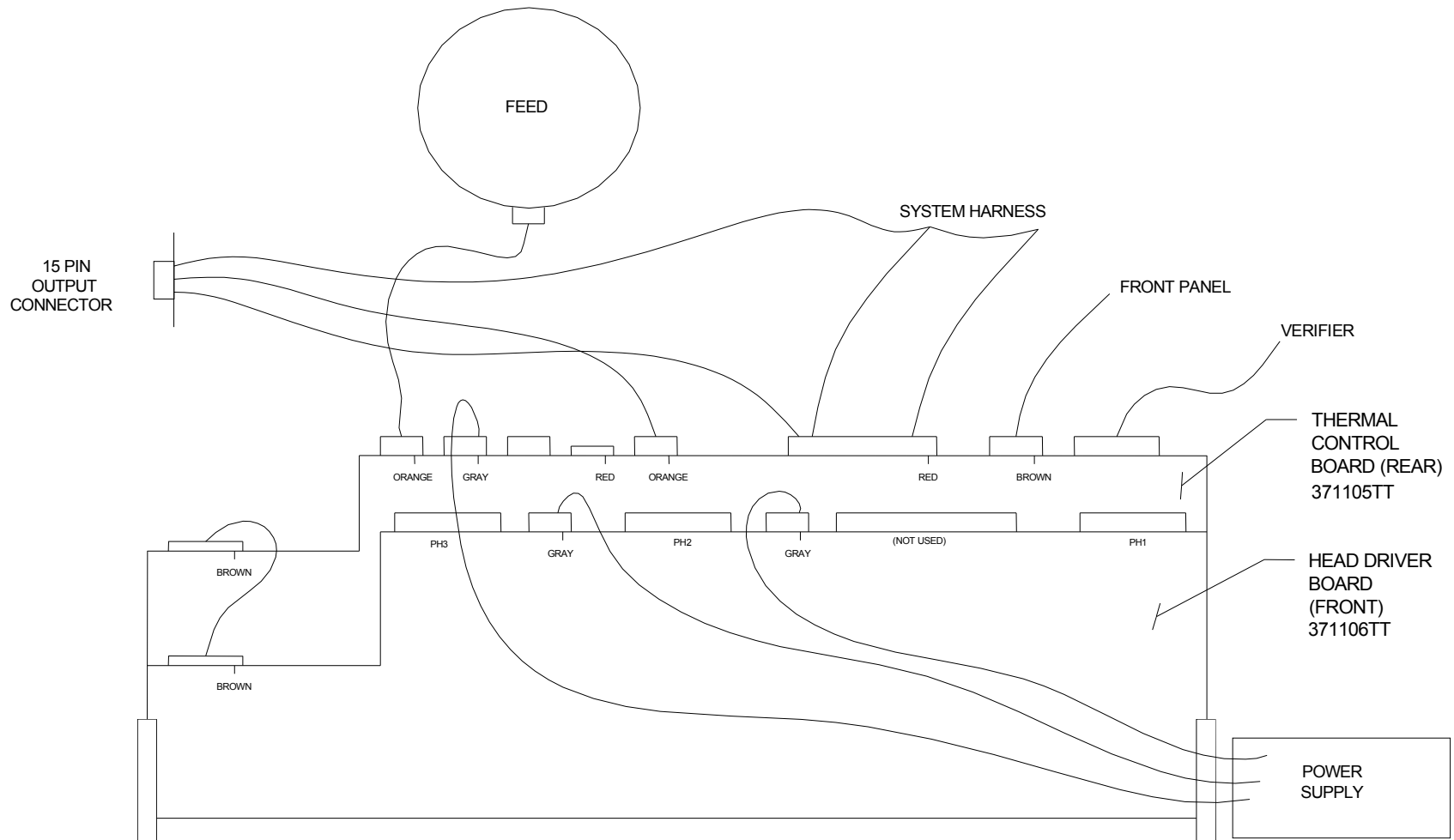

Electrical System Schematic

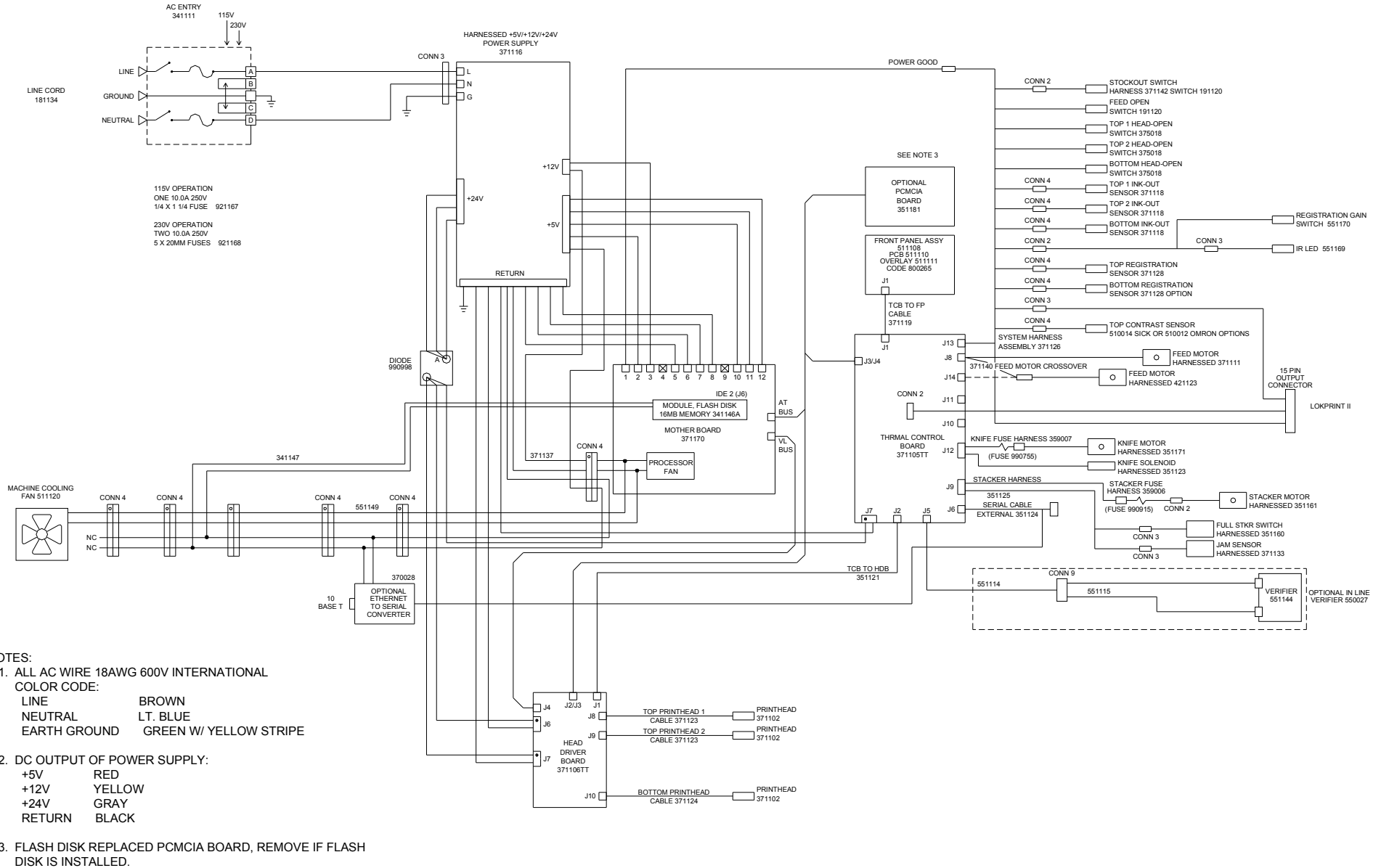

Motherboard Power Connectors

The power supply connector on any PC / XT or PC / AT compatible motherboard is made up of dual six-pin male connectors. Two female connectors from the power supply plug directly onto these male connectors. The following diagrams illustrates the proper method of attaching the connectors.

Ensure that all of the black wires are located next to each other in the center of the two connectors (as shown in the diagram below), and that the clamps on the back side of the connectors are secured along the PCB header. All pins should be covered.

Warning: Connecting the power supply incorrectly may cause irreversible (unwarranted) damage! Ensure that the power is turned off before connecting the power supply. Make certain that the 115 / 230VAC fuse drawer is in the correct position

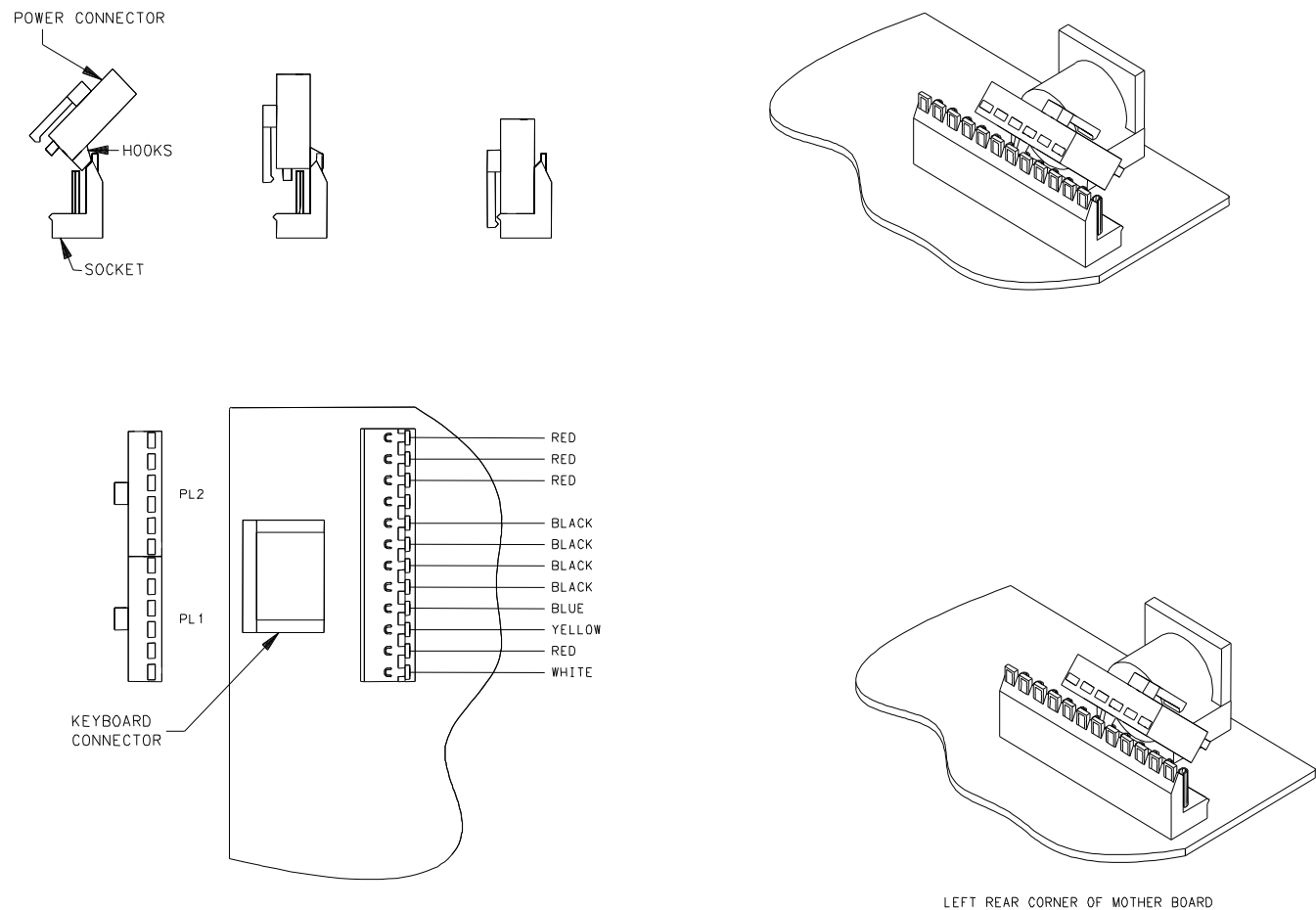

Mechanical Assembly Drawings

Unwind Assembly Drawing

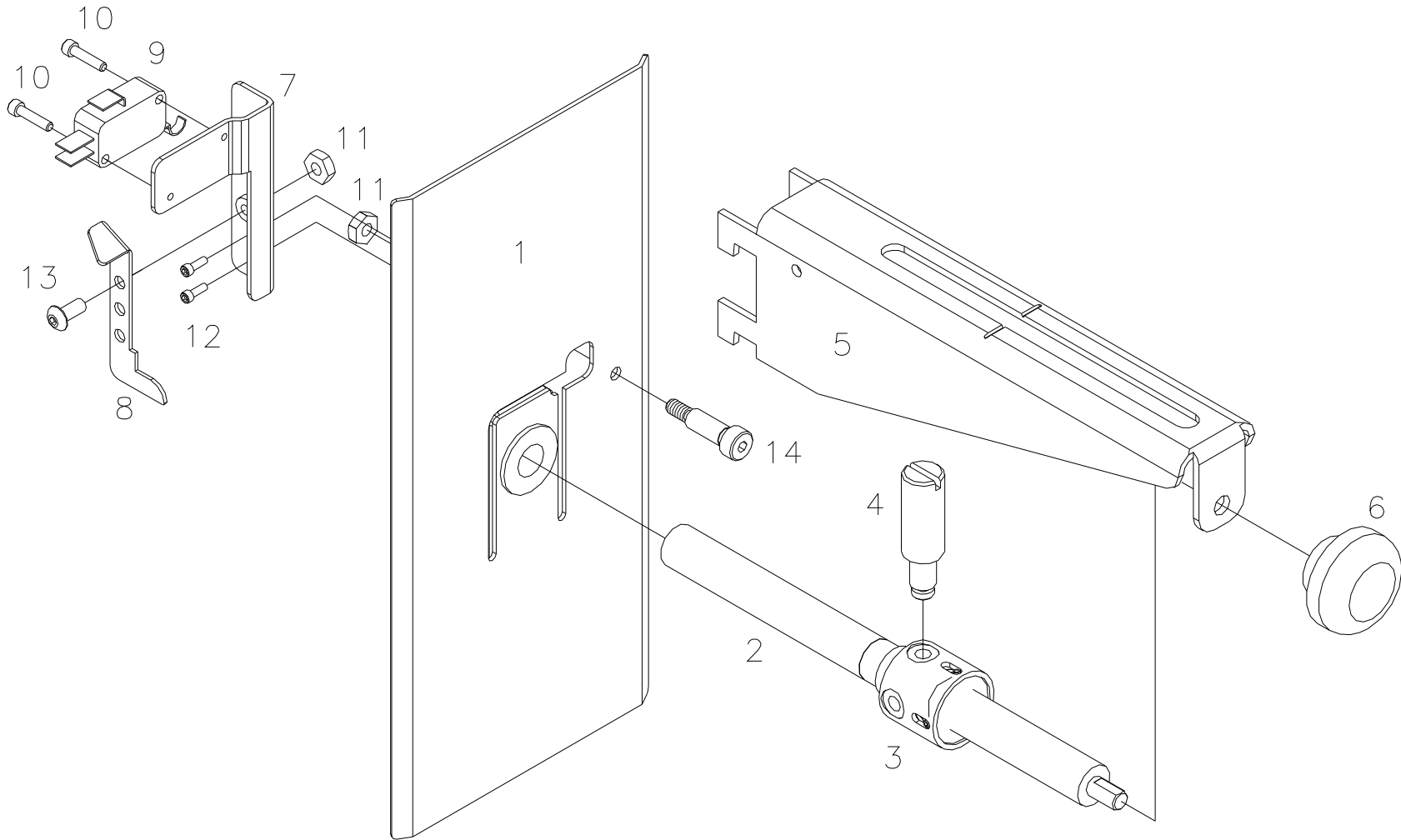

Unwind Parts List

Item	Part #	Description	Qty
1	373012	Web guide, Rear	1
2	373009	Lead screw, Tape unwind	1
3	373093	Assy, Unwind pressure, LKP	1
4	373010	Rod, Web guide, Outer	1
5	353002	Bracket, Unwind	1
6	105023	Impression Adj, Knob / SS Kit	1
7	373014	Bracket, Sensor mount	1
8	373013	Bracket, Stock out	1
9	191120	Micro switch	1
10	989973	4-40 x 1/2 Cap screw	2
11	990069	8-32 Hex nut	2
12	990000	2-56 x 1/4 Cap screw	2
13	990065	8-32 x 3/8 Button head screw	1
14	989995	3/15 x 5/8" Shld. Screw	1
15	371142	Stock out switch, Harness (*NS)	1
16	990513	Small wire tie (*NS)	1

(*NS) = Not Shown

Web Guide Assembly Drawing

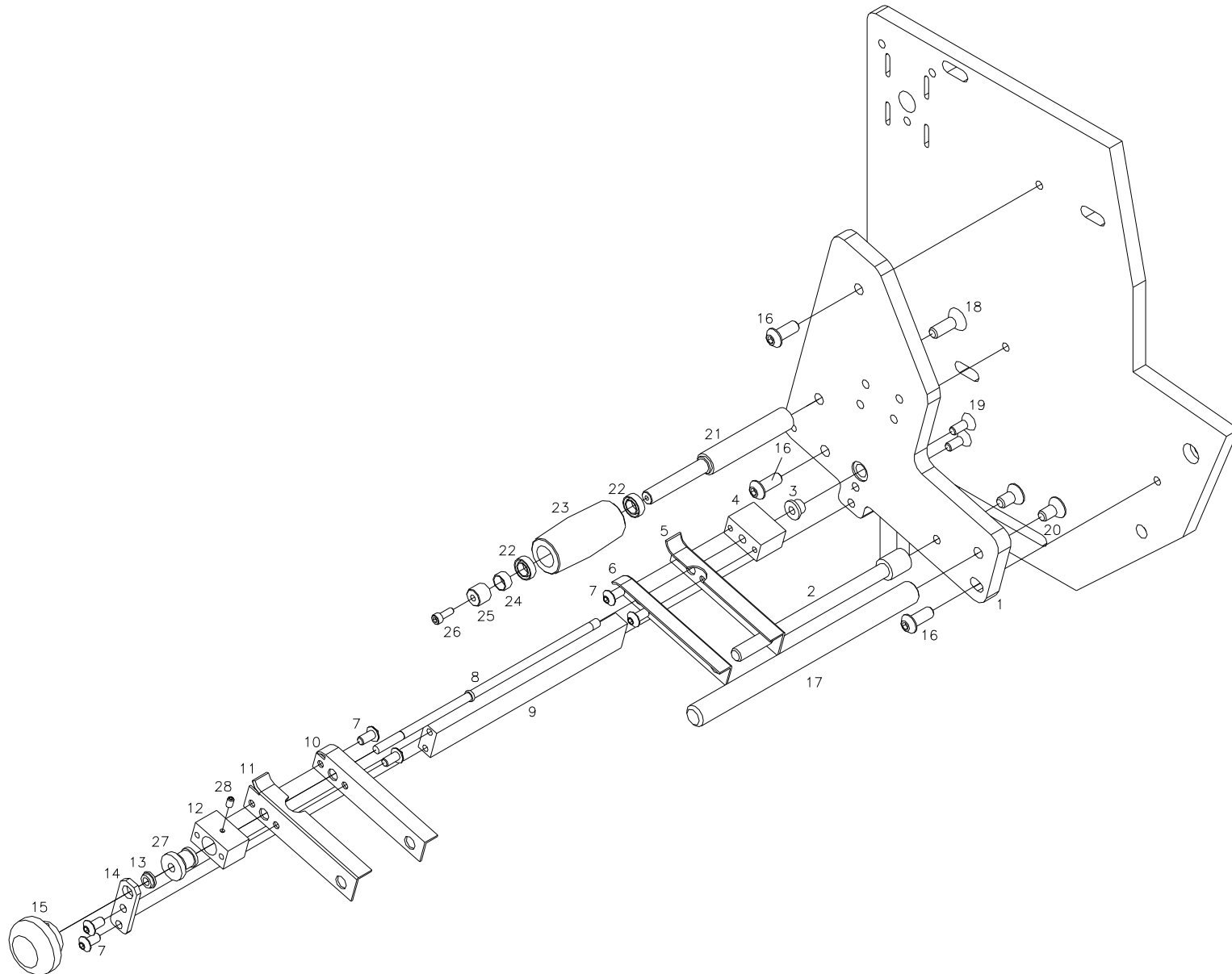

Web Guide Parts List

Item	Part #	Description	Qty
1	374046	Frame, Web guide	1
2	374113	Shaft, Ink turn bar	1
3	999099	3/16 x 5/16 x 1/4" Fl. Bushing	1
4	374111	R.H. Thread guide adj. Block	1
5	374104	Back (Top) Web guide	1
6	374103	Back (Bottom) Web guide	1
7	990090	10-32 x 3/8" Button head screw	6
8	374106	Shaft, Web guide adjust	1
9	374105	Bracket, Web adjust rod	1
10	374101	Front (Bottom) Web guide	1
11	374102	Front (Top) Web guide	1
12	374112	L.H. Thread, Guide adjust block	1
13	999100	3/16 x 5/16 x 1/8" Fl. Bushing	1
14	194013	Bracket, Web guide adjust	1

Item	Part #	Description	Qty
15	105023	Knob / SS	1
16	990166	1/4-20 x 5/8" Button head screw	3
17	194020	Web turn shaft	1
18	990133	1/4-20 x 3/4" Flat head screw	1
19	990196	10-32 x 1/2" Flat head screw	2
20	990416	1/4-20 x 1/2" Flat head screw	2
21	374110	Shaft, Spindle	1
22	343048	Bearing, Ball spindle	2
23	344063	Roller, Convex	1
24	344062	Spring, Compression	1
25	343101	Bearing, Retainer spindle	1
26	990016	6-32 x 3/8" Cap screw	1
27	554005	Adapter, Web guide	1
28	990025	6-32 x 1/4" Set screw	1

Drive Assembly Drawing

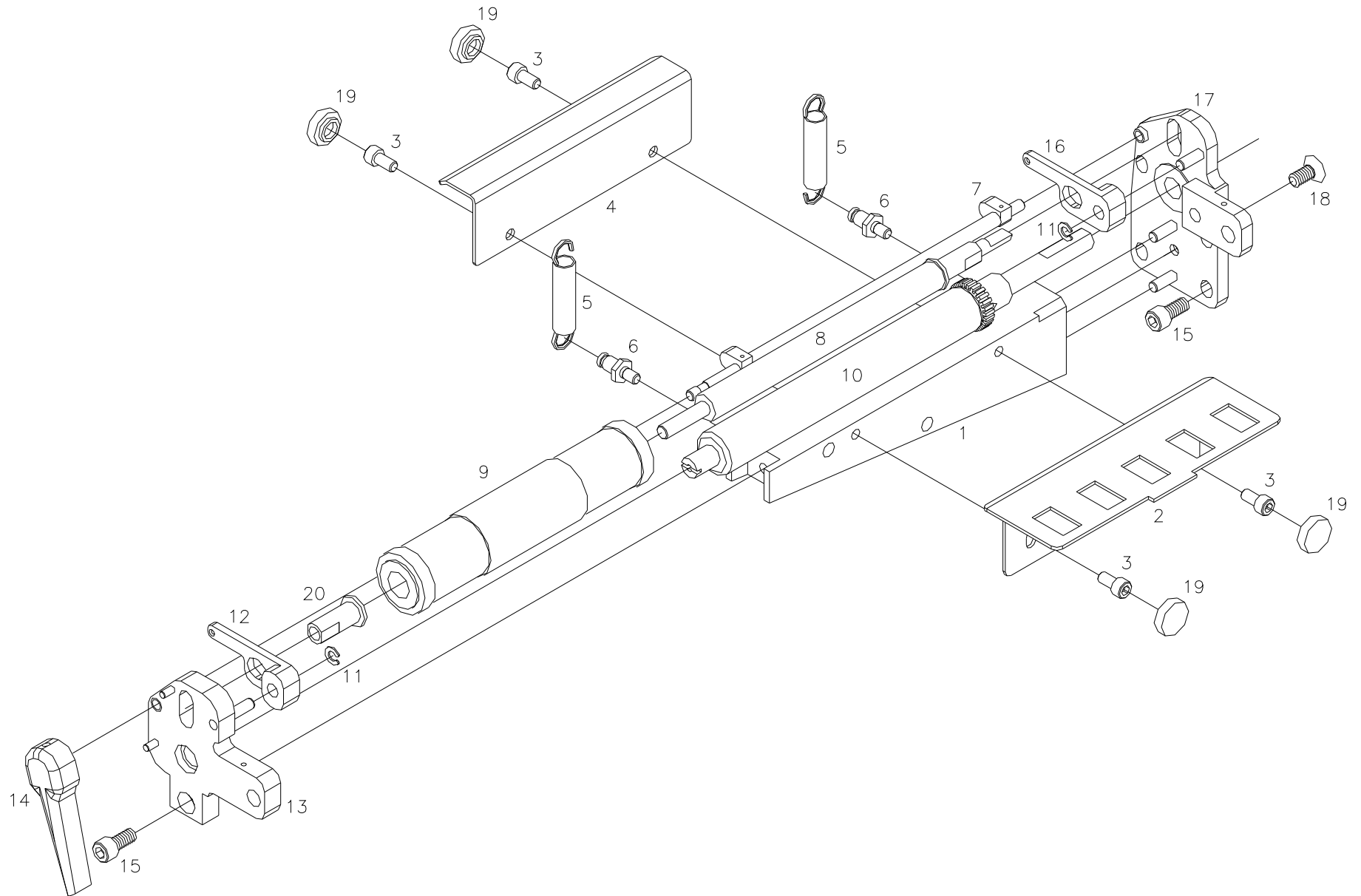

Drive Parts List

Item	Part #	Description	Qty
1	355018	Support, Knife / Drive / Print	1
2	354004	Bridge blade, Lower	1
3	990086	10-32 x 3/8 Cap screw	4
4	374044	Bridge plate, Web	1
5	991170A	Extension spring	2
6	514003	Pin, Spring anchor	2
7	514094	Lift cam assembly	1
8	514001	Shaft, Idler roller	1
9	374034	Tape roll idler, Molded	1
10	354094	Roller, Drive assembly	1
11	990325	3/16 "E" Ring	2
12	514009K	Spring lever, Front	1
13	374087	Assembly, Outer drive support	1
14	374047	Feed knob / SS	1
15	990120	1/4-20 x 1/2 Cap screw	5
16	514010K	Spring lever, Rear	1
17	374088	Assembly, Read drive support	1
18	990416	1/4-20 x 1/2 F.H. Screw	1
19	990313	#10 Thumb cap	4
20	514002	Sleeve, Idler shaft	1

Top - Printhead Assembly Drawing

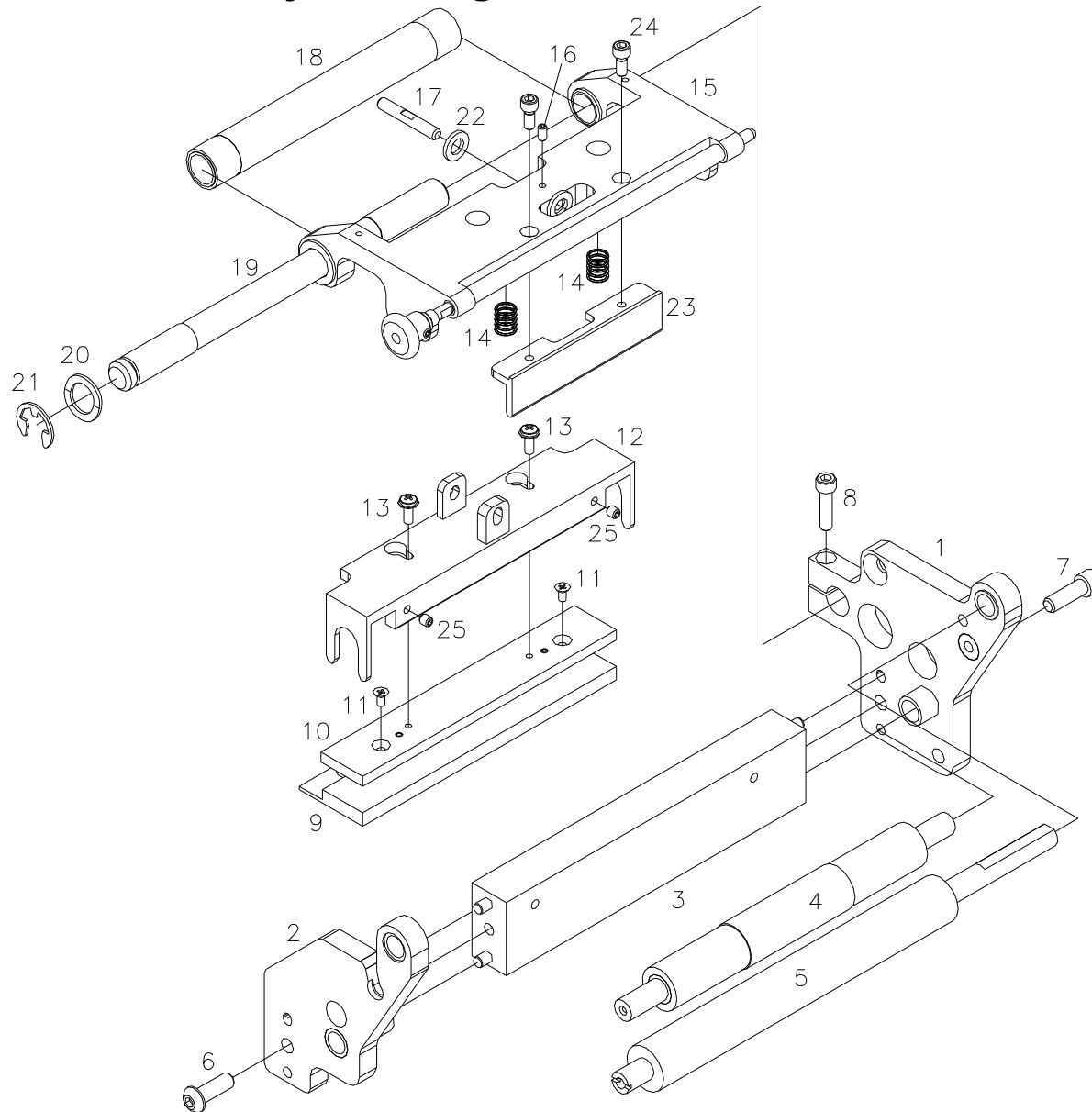

Top - Printhead Parts List

Item	Part #	Description	Qty
1	375076	Assy, Rear support, LKP	1
2	375077	Assy, Front support, LKP	1
3	375085	Support Beam, Print assembly	1
4	375054	Roller, 2-1/4" Cutdown (LKP)	1
5	356020	Roller, Molded (Ink)	1
6	990135	1/4-20 x 3/4 Button head screw	1
7	990122	1/4-20 x 3/4 Cap screw	1
8	990083	10-32 x 3/4 Cap screw	1
9	371102	300 DPI Convex head	1
10	375081	Assembly, Printhead mount	1
11	989543	3mm x 6mm Flat head screw	2
12	375049	Bracket, Head mount	1
13	991141	6-32 x 3/8 Sems screw	2
14	991142	Pressure spring	2
15	375082K	Assy, Printhead holder (Kit)	1
16	990025	6-32 x 1/4 Knurled point set screw	1
17	375056	Pin, Head holder	1
18	376032	Assembly, Ink turn roller	1
19	375014	Shaft, Head mount	1
20	990497	1/2" Wave Washer	1
21	990328	1/2" "E" Snap ring	1
22	990273	#10 Belleville washer	2
23	375060	Bracket, Peel blade (LKP)	1
24	990051	8-32 x 3/8 Cap screw	2
25	990058	8-32 x 1/4 Knurled cup point	2

Bottom – Printhead Parts List

Item	Part #	Description	Qty
1	356020	Roller, Molded (ink)	1
2	991142	Pressure spring	2
3	990135	1/4-20 x 3/4 Button head screw	1
4	375014	Shaft, Head mount	1
5	990497	1/2" Wave washer	1
6	375085	Support beam, Print assy	1
7	371102	300 dpi Convex head	1
8	375081	Assy, Plate print head mount	1
9	990058	8-32 x 1/4 Knurled cup point	2
10	989543	3mm x 6mm Flat head screw	2
11	990122	1/4-20 x 3/4 Cap screw	1
12	375049	Bracket, Head mount	1
13	990328	E-ring, 1/2"	1
14	990083	10-32 x 3/4 Cap screw	1
15	375078K	Assy, Print head holder	1
16	991141	6-32 x 3/8 Sems screw	2
17	376032	Assy, Ink turn roller	1
18	375054	Roller, 2 1/4" Cutdown (LKP)	1
19	375056	Pin, Head holder	1
20	990025	6-32 x 1/4 Knurled cup point	1
21	990273	Washer, #10 Belleville	2
22	375080	Assy, Support rear print module	1
23	375079	Assy, Support front print module	1
24	375060	Bracket, Peel blade (LKP)	1
25	990051	8-32 x 3/8 Cap screw	2

Ink Unwind / Rewind Assembly Drawing

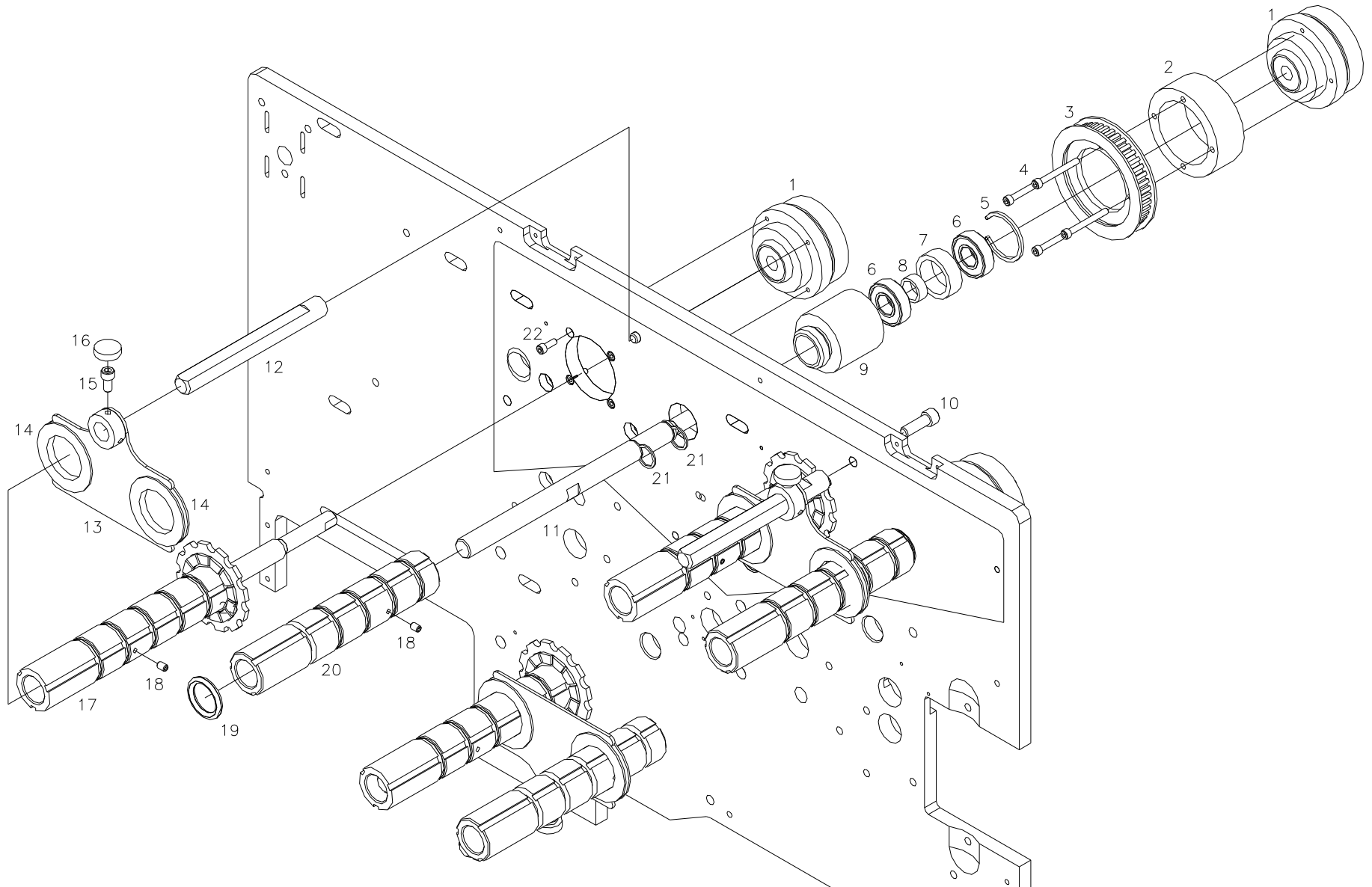

Ink Unwind / Rewind Parts List

Item	Part #	Description	2/0	2/1	1/1
			Qty	Qty	Qty
1	356201	Magnetic clutch	4	6	4
2	356202	Collar, Sprocket mount	2	3	2
3	376022	Sprocket, Altered	2	3	2
4	991086	6-32 x 1 1/4 Cap screw	8	12	8
5	991018	Internal snap ring	2	3	2
6	999002	Bearing	4	6	4
7	376025	Bearing spacer	2	3	2
8	376023	Bearing spacer	2	3	2
9	376016	Bearing housing	2	3	2
10	990122	1/4-20 x 3/4 Cap screw	2	3	2
11	356203	Shaft, Rewind	2	3	2
12	356016	Shaft, Foil bracket	2	3	2
13	376002	Ink guide	2	3	2
14	376003	Collar, Foil guide	4	6	4
15	990080	10-32 x 3/8 Cap screw	2	3	2
16	990313	#10 Thumb Cap	2	3	2
17	376096	Assembly, Arbor unwind	2	3	2
18	991084	8-32 x 1/4 Knurled cup point	4	6	4
19	990355	"O" Ring, Foil 3/4"	10	15	10
20	356204K	Assy, Rewind arbor w/ Bushings	2	3	2
21	991089	Collar, 1/2" Retaining ring	4	6	4
22	990016	6-32 x 3/8 Cap screw	8	12	8
23	376035	Shaft, Unwind	2	3	2

Web Tension Guide Assembly Drawing

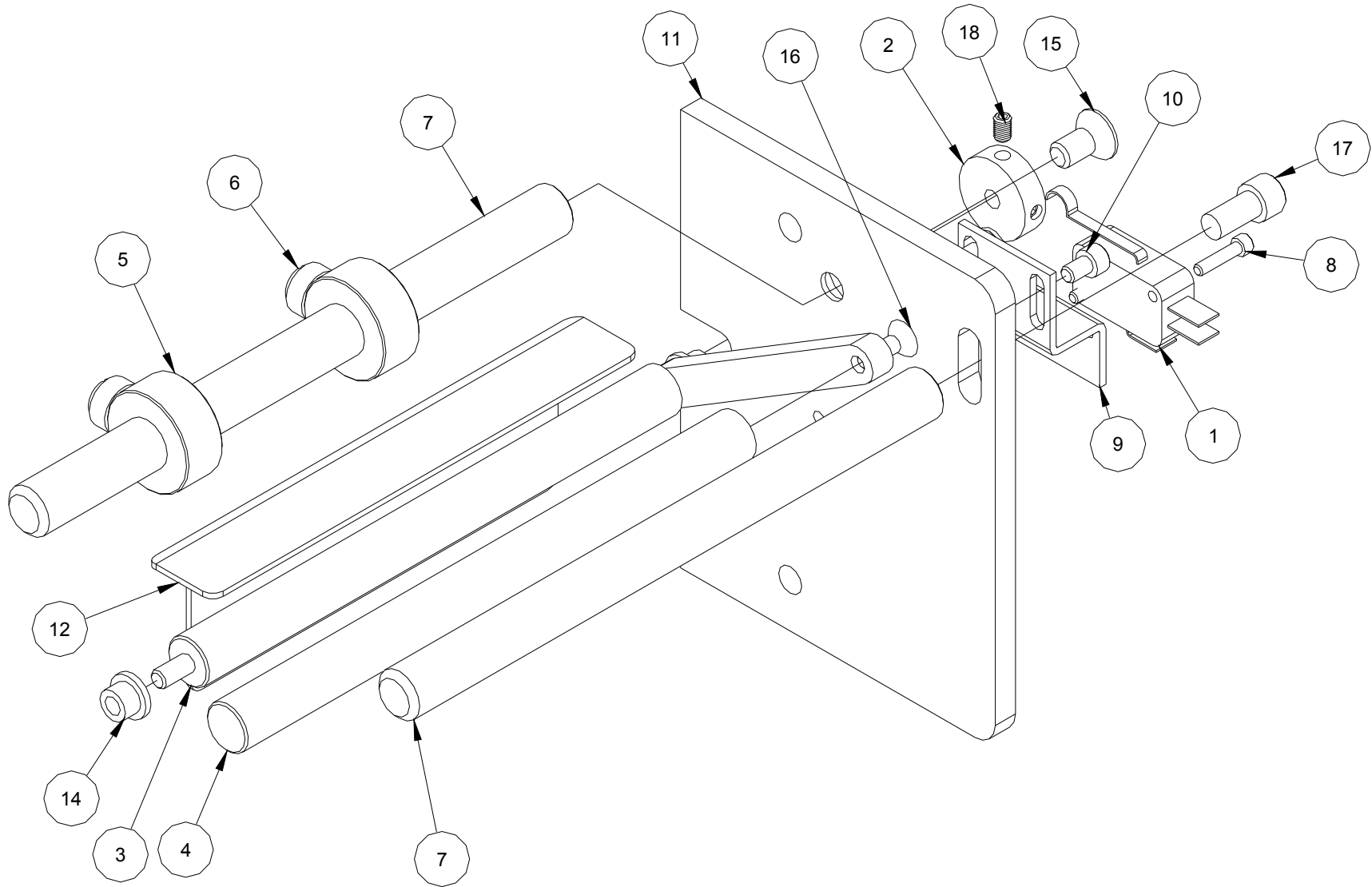

Web Tension Guide Parts List

Item	Part #	Description	Qty
1	191120	Stock out micro switch	1
2	564088	Bracket, Roller	1
3	564087	Shaft, Support	1
4	564089	Shaft, Roller	1
5	990374	1/2 Collar	2
6	990484	1/4-20 x 1/2 Nylon slotted screw	2
7	194020	Web turn shaft	2
8	989973	4-40 x 1/2" Socket hd cap screw	2
9	563006	Bracket, Sensor	1
10	990050	8-32 x 1/4" Socket hd cap screw	2
11	563001	Bracket, Guide mount	1
12	564097	Bracket, Bridge blade	1
13	561165	Harness, Web tension switch	1
14	999099	3/16 x 5/16 x 1/4" FL. Bushing	2
15	990416	1/4-20 x 1/2" Flat hd cap screw	1
16	990056	8-32 x 1/2" Flat hd cap screw	1
17	990120	1/4-20 x 1/2" Socket hd cap screw	1
18	990058	8-32 Set screw	2

Drive Belt Routing Drawing

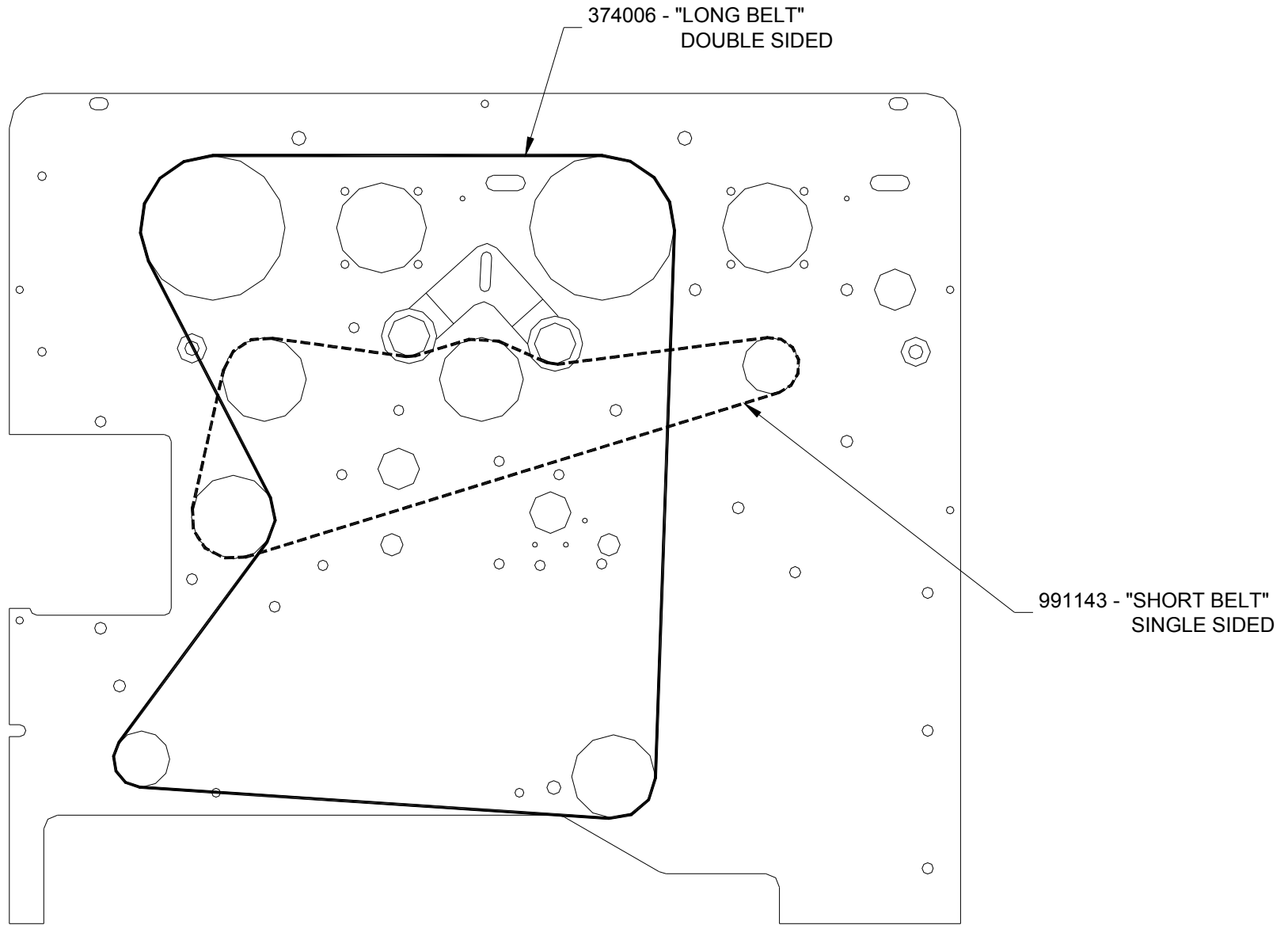

Free Manuals Download Website

<http://myh66.com>

<http://usermanuals.us>

<http://www.somanuals.com>

<http://www.4manuals.cc>

<http://www.manual-lib.com>

<http://www.404manual.com>

<http://www.luxmanual.com>

<http://aubethermostatmanual.com>

Golf course search by state

<http://golfingnear.com>

Email search by domain

<http://emailbydomain.com>

Auto manuals search

<http://auto.somanuals.com>

TV manuals search

<http://tv.somanuals.com>