

Use & Care Guide

Model: 7116572

Char-Broil® Natural Gas Conversion Kit

**This Natural Gas Conversion Kit can be used ONLY with
Dual Fuel™ grills.**



If you have questions or need assistance during assembly, please call 1-800-241-7548 (USA) or 1-800-387-6057 (Canada)
To insure your satisfaction and for follow-up service, register your grill online at www.grillregistration.com

 **DANGER** 

If you smell gas:

1. Shut off gas to the appliance.
2. Extinguish any open flame.
3. Open lid.
4. If odor continues, keep away from the appliance and immediately call your gas supplier or your fire department.

 **WARNING** 

1. Do not store or use gasoline or other flammable liquids or vapors in the vicinity of this or any other appliance.
2. An LP Tank not connected for use shall not be stored in the vicinity of this or any other appliance.

Call the Grill Information Center for Help and Parts
Missing Parts? Assembly Questions? Operation Problems?
Before returning grill to store, call **1-800-241-7548**

 **WARNING** 

Do not attempt to repair or alter this conversion kit for any assumed defect. Any modification to this assembly will void your warranty and create the risk of a gas leak and fire. Use only authorized replacement parts supplied by manufacturer.

To Installer/Assembler: Leave these instructions with consumer.

To Consumer: Keep this manual for future reference.

 **CAUTION** 

Some parts may contain sharp edges, especially as noted in these instructions.
Wear protective gloves if necessary.

 **CAUTION** 

For residential use only. Do not use for commercial cooking.

 **WARNING** 

CALIFORNIA PROPOSITION 65

1. Combustion by-products produced when using this product contain chemicals known to the State of California to cause cancer, birth defects, and other reproductive harm.
2. This product contains chemicals, including lead and lead compounds, known to the State of California to cause cancer, birth defects or other reproductive harm.

Wash your hands after handling this product.

Safety Symbols

The symbols and boxes shown below explain what each heading means. Read and follow all of the messages found throughout the manual.

 **DANGER** 

DANGER: Indicates an imminently hazardous situation which, if not avoided, will result in death or serious injury.

 **WARNING** 

WARNING: Be alert to the possibility of serious bodily injury if the instructions are not followed. Be sure to read and carefully follow all of the messages.

 **CAUTION** 

CAUTION: Indicates a potentially hazardous situation which, if not avoided, may result in minor or moderate injury.

 **WARNING** 

- Read and follow all Safety, Assembly, and Use and Care Instructions in this Guide before assembling and cooking with this grill.
- Failure to follow all instructions in this Use and Care Guide may lead to fire or explosion, which could result in property damage, personal injury or death.

TABLE OF CONTENTS

Warning & Cautions	2
Table Of Contents	3
Use and Care	3-4
Parts List/ Parts Diagram	4
Grill Matrix	5
Section A	5-7
Section B	8-9
Section C	10-12
Section D	13-15
Section E	15-18
Section F	18-20
Section G	20-22
Troubleshooting	22

USE & CARE

Natural Gas Connections and Service Regulators Above 1/2 psi.

Prior to 1998, all residential gas service regulators were set with an outlet pressure of 7 inches water column.

In the 1998 edition of NFPA 54, the National Fuel Gas Code, a change was made allowing service regulators of 2 and 5 psi.

With this change it was also required that an in line regulator be connected between the service regulator and the appliance regulator if the 2 or 5 psi system is used. This additional regulator is not supplied with the product.

It is possible for a consumer, making the connection themselves, or a plumber, not checking, to tap into a 2 or 5 psi line. If a pressure of 2 psi or greater is supplied to the appliance regulator on certain grills it will shut down and not deliver any gas to the grill. The included quick disconnect socket and hose should not be used at pressures above 1/2 psi.

If the quick disconnect socket, hose, and grill are properly connected and still not getting gas, delivery pressure needs to be verified. If pressure is greater than 1/2 psi, make sure that an in line regulator is present.

Once the grill has been over-pressured, the regulator may or may not have been damaged. The best practice is to replace the regulator.



WARNING



Do not use hard metal piping of any kind to connect this type of grill to natural gas source. Use only hose specified by manufacturer. Using hard metal piping or convoluted metal tubing is an unsafe practice. Movement of the grill can cause breakage of metal pipe.

CONNECTING YOUR GRILL TO THE NATURAL GAS SOURCE:

1. A professionally-installed shut-off valve between the supply piping and the socket is recommended, but not required, by the National Fuel Gas Code. Socket connection must be made outdoors.
2. Coat the gas supply pipe nipple with gas resistant pipe dope or approved teflon tape. Screw socket onto gas supply pipe (house gas source) as shown in Figure A below, and wrench-tighten.

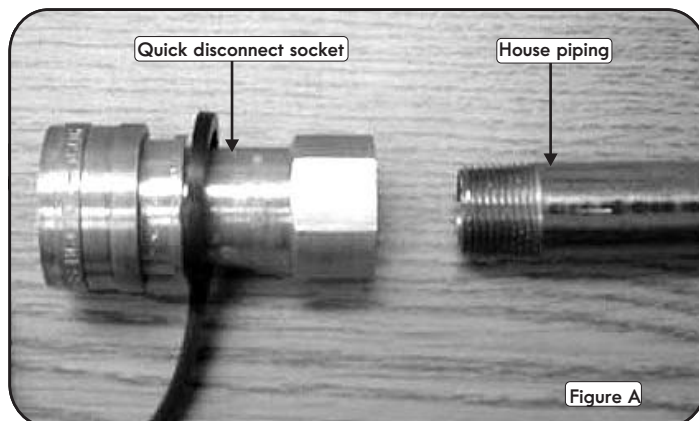

3. Pull back the sleeve on the quick disconnect socket and insert the unattached end of the gas hose into the socket. Release the sleeve and continue pushing the hose into the socket until the sleeve snaps into the locked position. See Figure B.

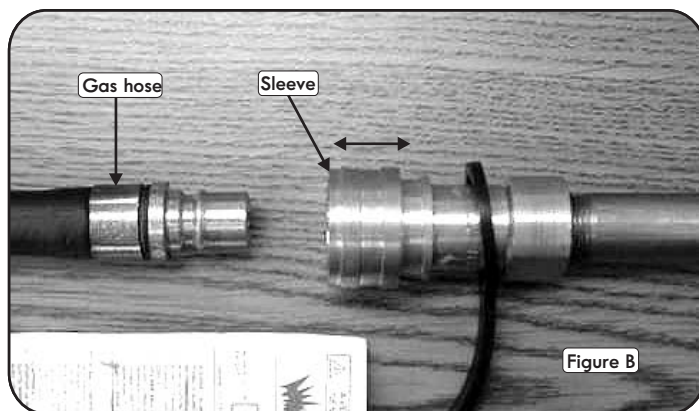

4. When the quick disconnect socket and the gas hose are connected, a valve in the socket opens automatically to permit full gas flow. When the gas hose is disconnected, the valve in the socket instantly and positively shuts off the flow of gas. Because the valve in the socket positively shuts off the flow of gas, the grill can be disconnected from the gas source by disconnecting the gas hose from the quick disconnect socket. The socket should be left attached to the gas source (house piping). Figure C shows properly connected hose and socket.

USE AND CARE CON'T.

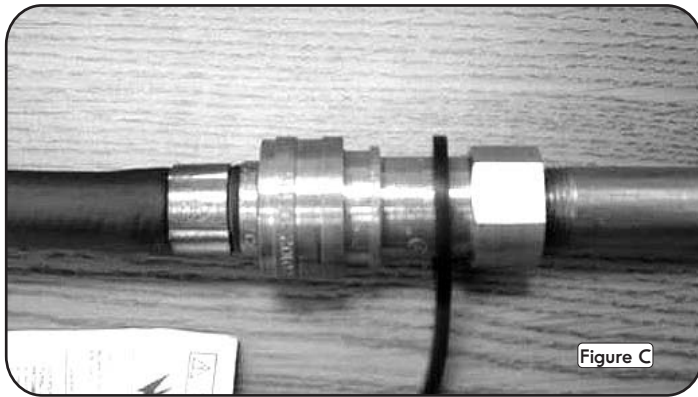

With proper assembly, the gas hose cannot be removed without pushing the quick disconnect sleeve back. To disconnect, push sleeve back and pull plug out of sleeve (this automatically shuts off gas).

Please Note: Hose and assembly are C.S.A. listed for natural gas, manufactured gas, mixed gas and for liquefied petroleum and for LP Gas-Air mixtures on basis of 0.64 specific gravity for 1000 BTU's per cubic foot of gas at 0.3 in. water column pressure drop. Only ANSI Z21.54 approved hoses should be used with this grill.

The appliance and its individual shut off valve must be disconnected from the gas supply piping system during any pressure testing on that system at test pressures in excess of 1/2 psig (3.5kPa).

The appliance must be isolated from the gas supply piping system by closing its individual manual shutoff valve during any pressure testing of the gas supply piping system at test pressures equal to or less than 1/2 psi (3.5kPa).

PARTS LIST

Key	Qty.	Description	Part No.
A	6	Main & Sideburner Natural Gas Bezel (Large Bezel)	3499856
B	1	Rotisserie Burner Natural Gas Bezel (Small Bezel)	3498841
C	1	Orifice Driving Tool	80004378
D	1	10 ft., 3/8" Natural Gas Hose	3496263
E	1	Rotisserie Burner Natural Gas Orifice (Red Dot-1.45MM)	80007768
F	3	Main Burner Natural Gas Orifice (Blue Dot-#57)	3498451
G	1	Searing Burner Natural Gas Orifice (Green Dot-1.65MM)	3498837
H	2	Sideburner & Rotisserie Burner Natural Gas Orifice (Yellow Dot-#53)	3499765

Note: Illustrations are not to scale.

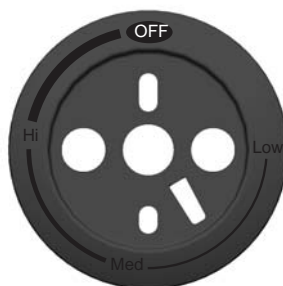

A

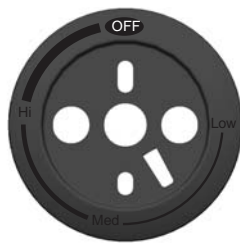

B



C



D



1.45mm
Red Dot

E



#57
Blue Dot

F



1.65mm
Green Dot

G



#53
Yellow Dot

H

Tools required for assembly:

Orifice Driving Tool - Provided

Adjustable Wrench - Not Provided

Standard #2 Phillips Screwdriver - Not Provided

NOTE: Magnetic tip screwdrivers are recommended, but not required.

Model 415.16135110



For Conversion Use Sections:

A, B, F

Parts Required:

5- Large Bezels

1 -10' Hose

1-Orifice Driving Tool

Model 415.16649011



For Conversion Use Sections:

A, B, D, E

Parts Required:

6 -Large Bezels

1 -Small Bezel

1 - 10' Hose

1 -Orifice Driving Tool

1 -Orifice (1.45MM Red Dot)

Model 415.16138110

415.16167210

415.16164210



For Conversion Use Sections:

A, B, F

Parts Required:

5 -Large Bezels

1 - 10' Hose

1 -Orifice Driving Tool

Model 415.16139110

415.16139111



For Conversion Use Sections:

A, C, D, G

Parts Required:

5 -Large Bezels

1 -Small Bezel

1 - 10' Hose

1 -Orifice Driving Tool

3 - #57 Orifice (Blue Dot)

2 - #53 Orifice (Yellow Dot)

1 -1.65MM (Green Dot)

Section A

A1

First, make sure all Control Knobs are in the OFF position, LP tank valve is closed, and Tank is disconnected from Regulator and removed from Grill.

Next, open Lid and remove Warming Rack, Cooking Grates, and Heat Diffusers.

Your Grill may differ from illustrations shown. This manual covers a variety of grills styles, use pictures as reference only.

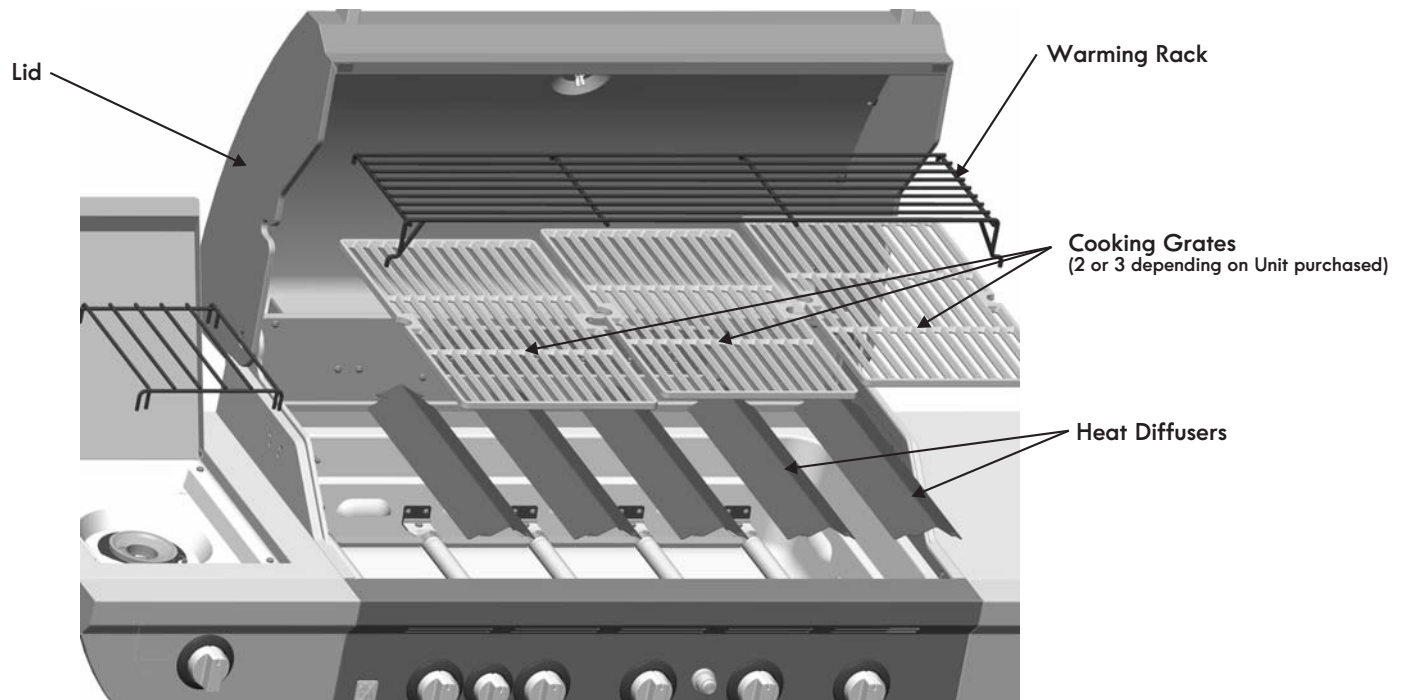

A2

Using a wrench (not provided) remove LP Regulator Hose Assembly from Manifold Connection. Save removed LP Regulator Hose assembly for converting back to LP Tank Gas. Your LP Regulator hose will be located under the Sideburner Shelf.

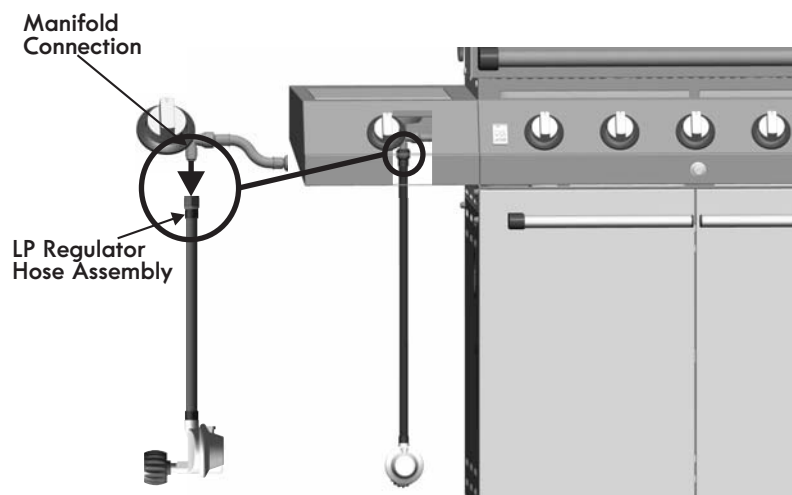

A3

Position Natural Gas Hose Assembly behind cart up to Manifold Connection.

Secure the Natural Gas Hose Assembly, to Manifold Connection, using a wrench (not provided).

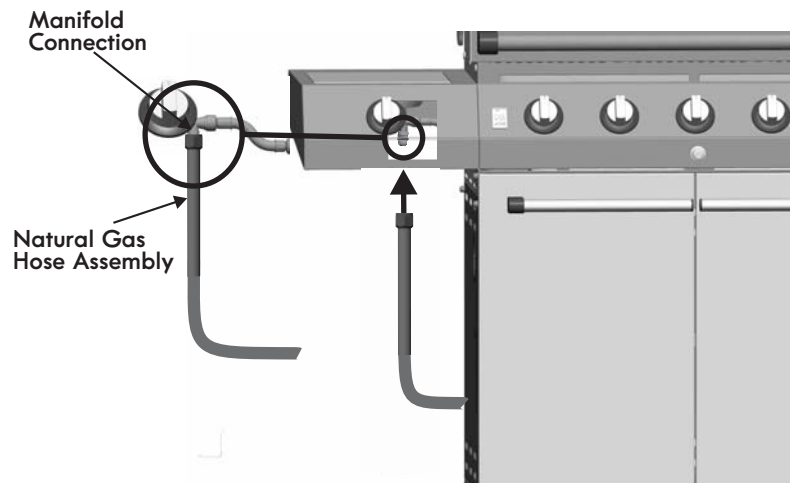

A4

Leak Testing Natural Gas Hose

Turn all grill knobs to OFF.

Brush soapy solution onto areas where bubbles are shown in picture.

If "growing" bubbles appear, there is a leak. Retighten connections. If leak cannot be stopped do not try to repair. Call Sears for replacement parts.

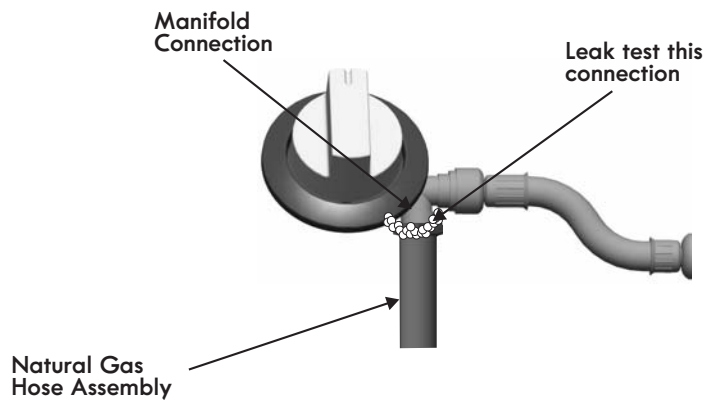

Section B

B1

Remove Hitch Pins and remove Carryover Tubes.

Remove Hitch Pins at back of Burners to detach Burners from Burner Brackets.

Lift back of Burner while sliding Burner out of Firebox, disengaging burners from Valves.

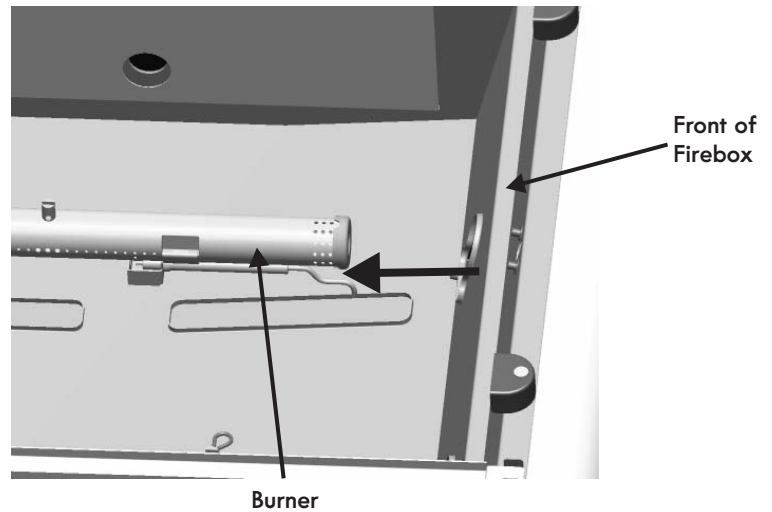
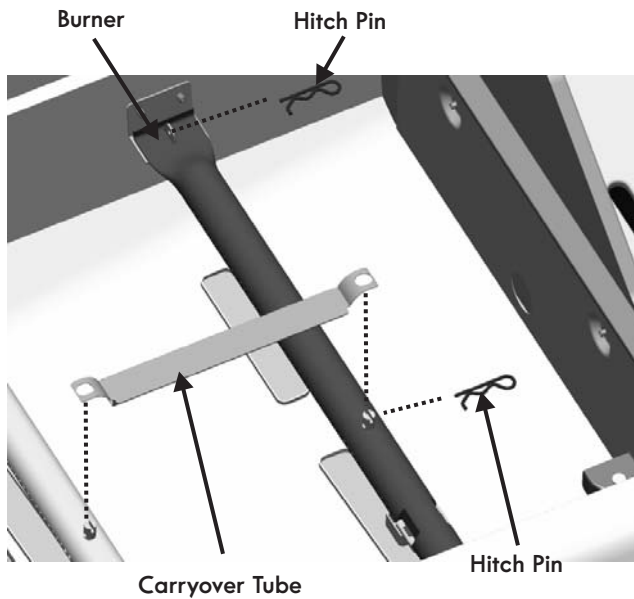

B2

Insert Orifice Driving Tool into Firebox Burner openings and unscrew Orifices from ends of Valves. Save removed orifices for converting back to LP Tank Gas. These grill valves are designed to work with Natural Gas once Orifices are removed unless otherwise noted.

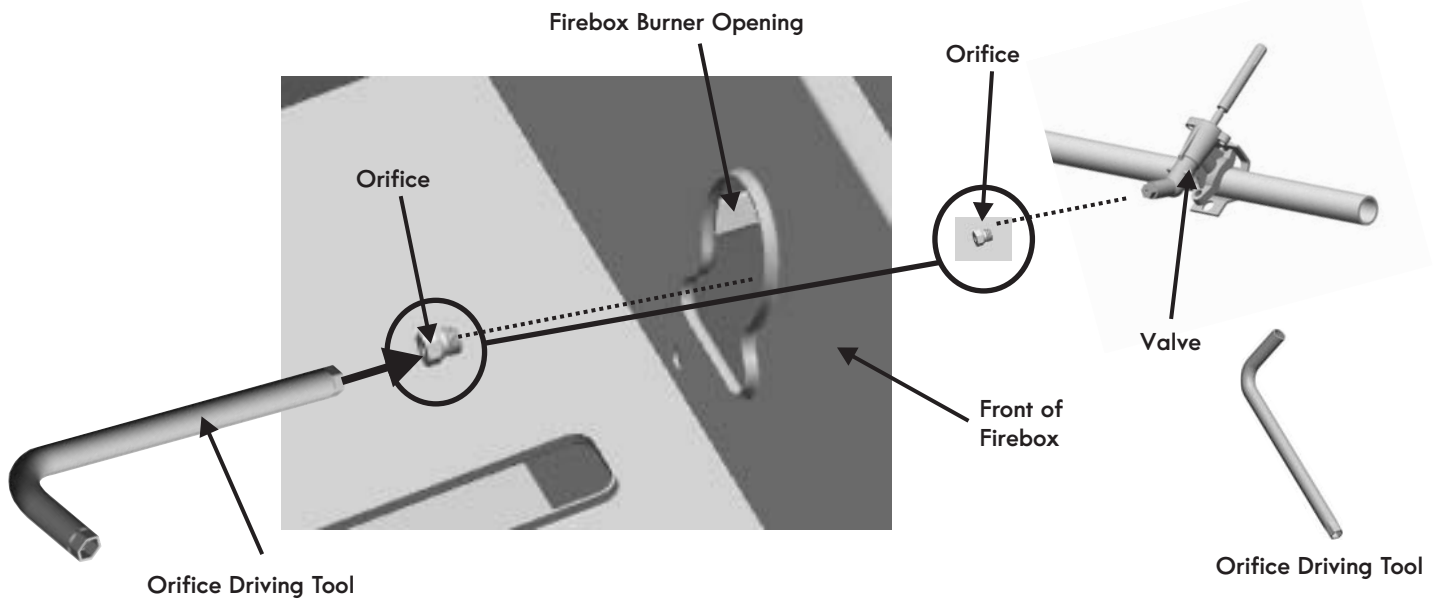

Section B Con't.

B3



WARNING



Bezels must be replaced one at a time. Removing more than one bezel at a time may cause misalignment of manifold.

Pull the Tube Burner Control Knob off of Valve Stem.

Remove two Screws and two Washers that secure Bezel to the Control Panel. Save removed Bezel for converting back to LP Tank Gas.

Install new Natural Gas Bezel provided with Kit (see illustration below) in place of old Bezel onto Control Panel, and secure using previously removed Screws and Washers. Assure proper alignment with control knob before fully tightening. Note: New bezels will change the rotation for the control knob to properly control ignition and flames for your grill.

Press Control Knob back onto Valve Stem. Make adjustments needed to Bezel for free movement of Control Knob

Repeat for each Bezel.

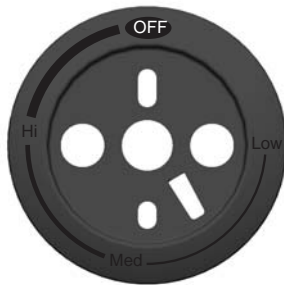

Large Bezel

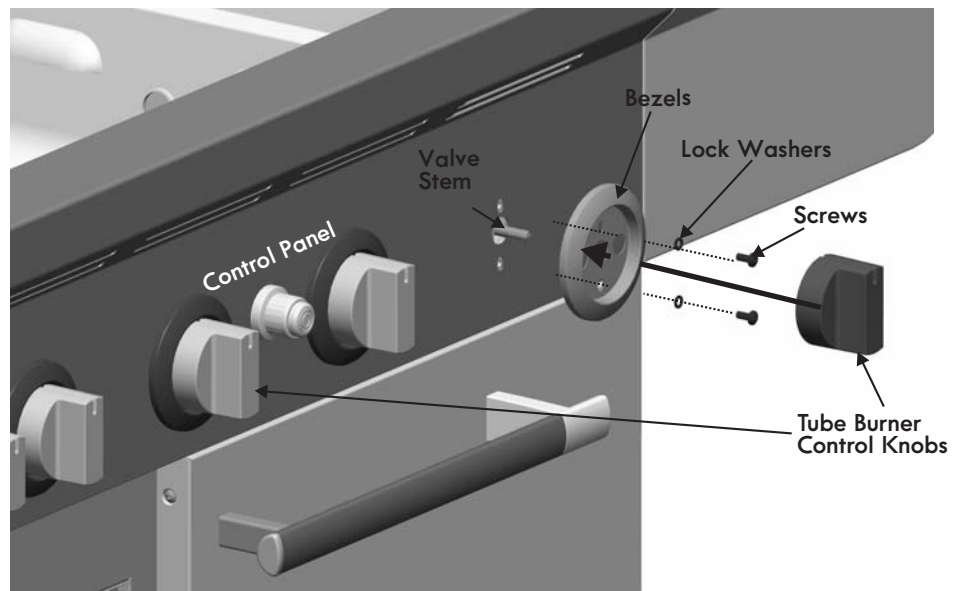

B4

Reinstall Tube Burners

Insert Tube Burners into Firebox Burner holes over Valves with Ignitor Assembly downward, making sure Tube Burner engages Valve properly. See diagram below.

Secure Tube Burners to Burner Brackets with previously removed Hitch Pins. Replace Carryover tubes and secure with Hitch Pins previously removed. Reference illustration B1.

Correct
burner-to-valve
engagement



Incorrect
burner-to-valve
engagement



Tube Burner

Section C

C1

Remove Hitch Pins and remove Carryover Tubes.

Remove Hitch Pins at back of Burners to detach Burners from Burner Brackets.

Lift back of Burner while sliding Burner out of Firebox, disengaging burners from Valves.

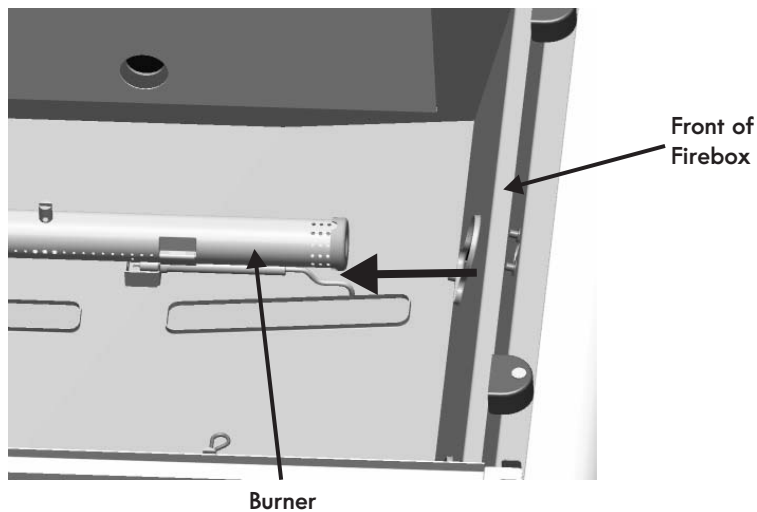
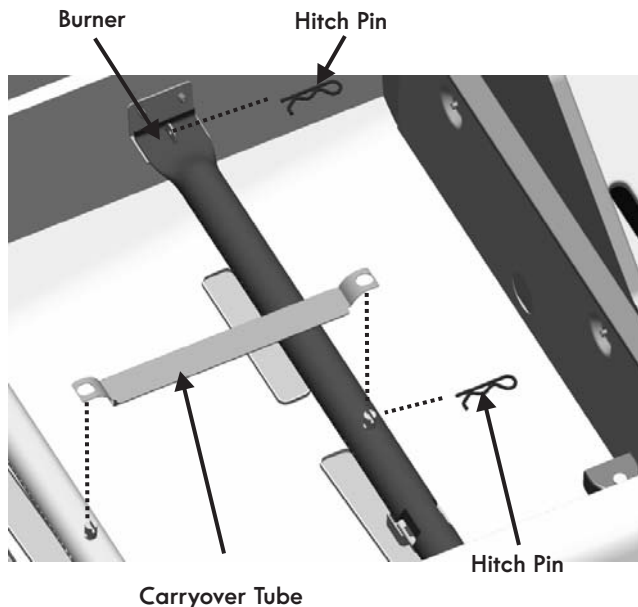

C2

Insert Orifice Driving Tool into Firebox Burner openings and unscrew Orifices from ends of Valves. Save removed orifices for converting back to LP Tank Gas. Do not mix with other Orifices removed from grill.

Replace with Natural Gas Orifice #57 (Blue Dot) and secure tightly to Valve.

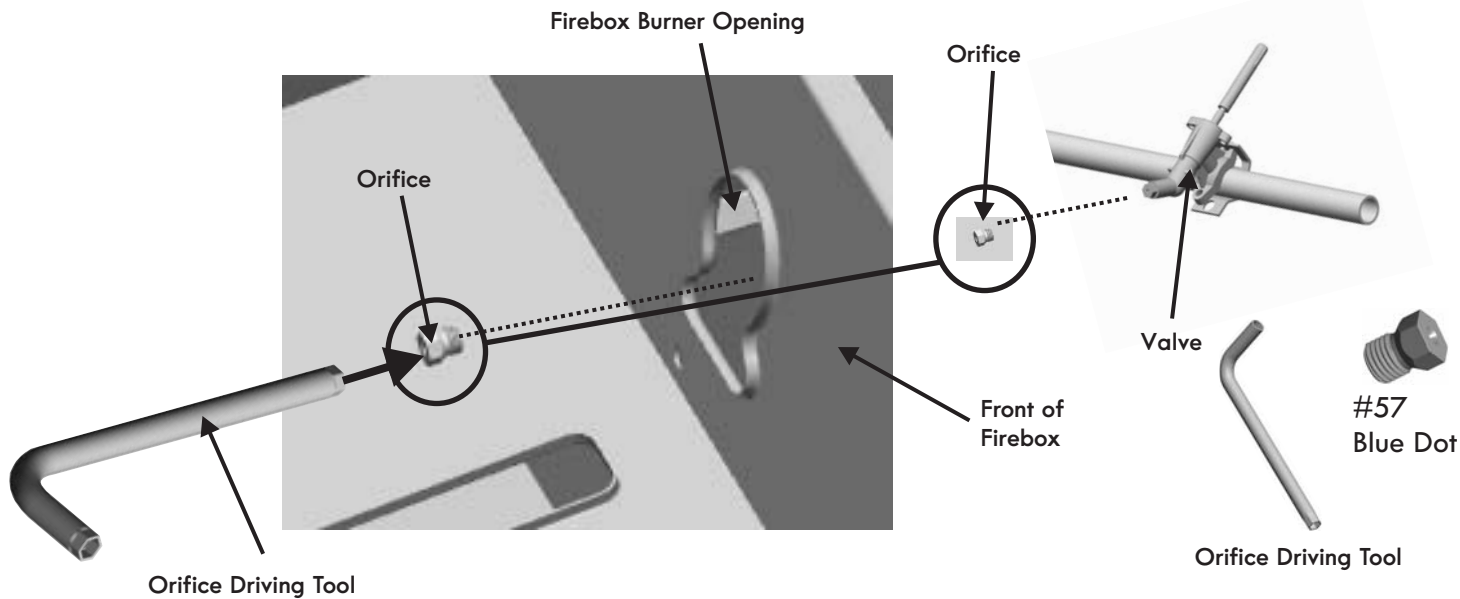

Section C Con't.

C3

Remove two Screws, two Lock Washers and two Flat Washers at the back of Searing Burner.

Slide Searing Burner back and up to remove Burner.

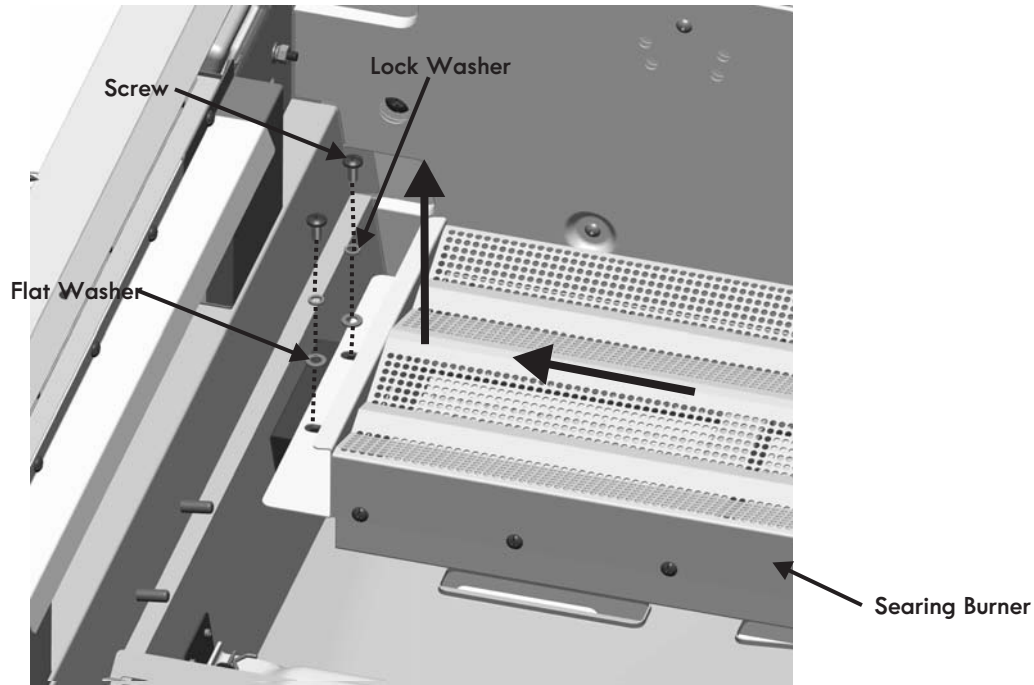

C4

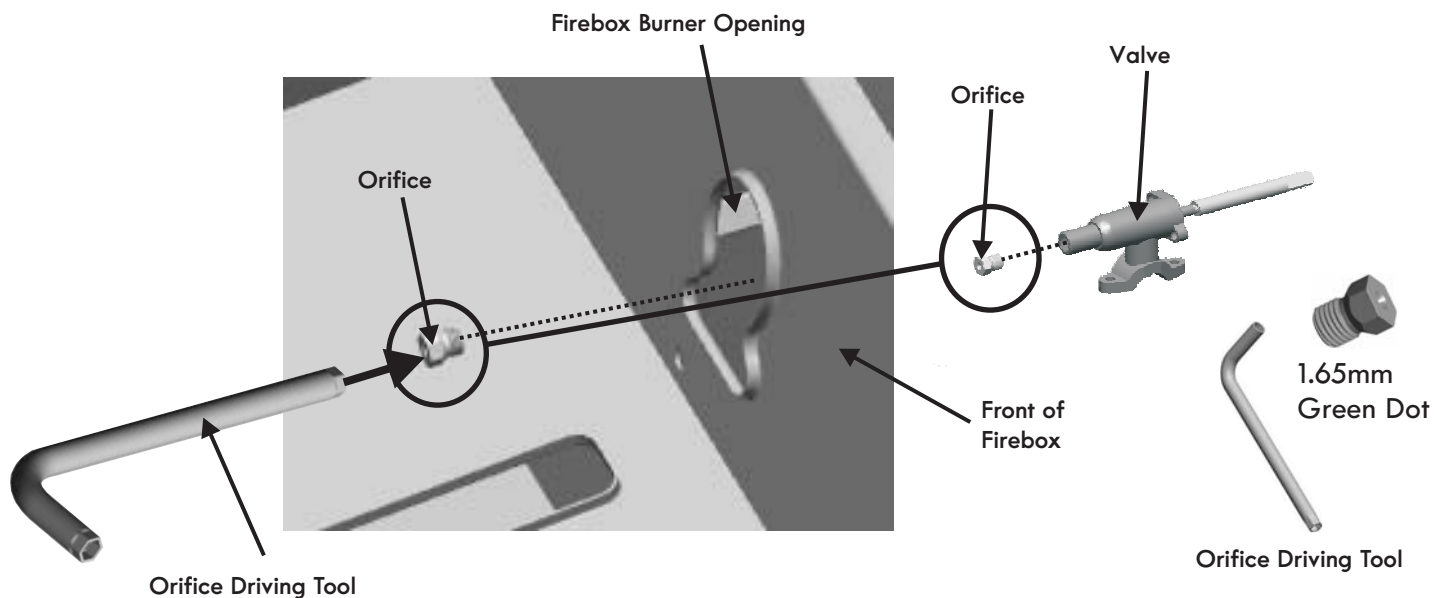

Insert Orifice Driving Tool into Firebox Burner openings and unscrew Orifice from end of Valve. Save removed orifice for converting back to LP Tank Gas. Do not mix with Orifices removed from Main Burners.

Replace with Natural Gas Orifice 1.65 (Green Dot) and secure tightly to Valve.



Section C Con't.

C5

 **WARNING** 
Bezels must be replaced one at a time. Removing more than one bezel at a time may cause misalignment of manifold.

Pull the Tube Burner Control Knob off of Valve Stem.

Remove two Screws and two Washers that secure Bezel to the Control Panel. Save removed Bezel for converting back to LP Tank Gas.

Install new Natural Gas Bezel provided with Kit (see illustration below) in place of old Bezel onto Control Panel, and secure using previously removed Screws and Washers. Assure proper alignment with control knob before fully tightening. Note: New bezels will change the rotation for the control knob to properly control ignition and flames for your grill.

Press Control Knob back onto Valve Stem. Make adjustments needed to Bezel for free movement of Control Knob

Repeat for each Bezel.

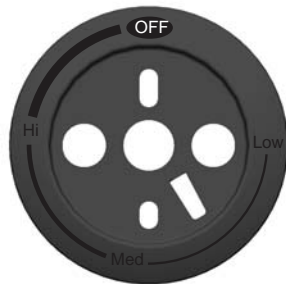

Large Bezel

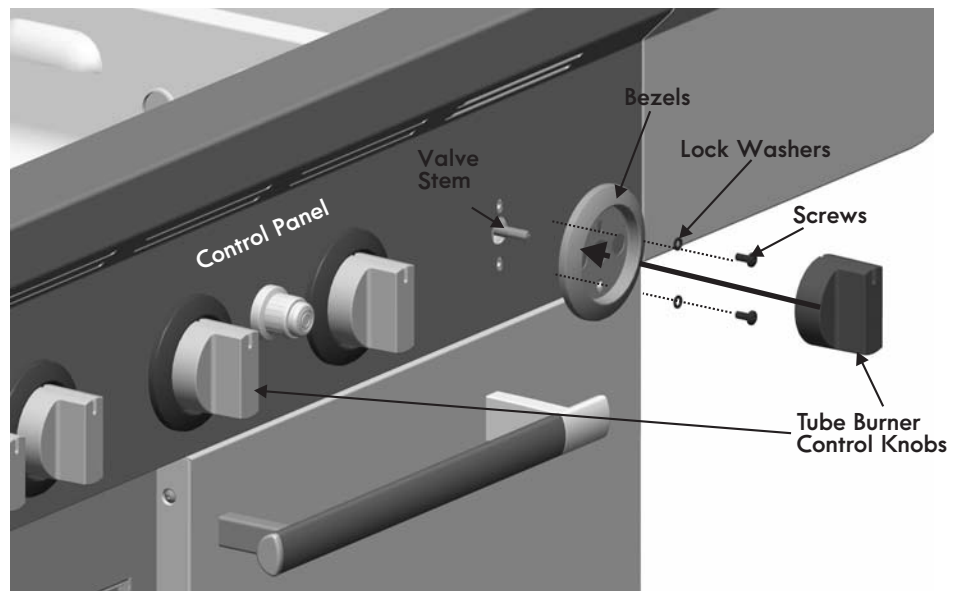

C6

Reinstall Tube Burners

Insert Tube Burners into Firebox Burner holes over Valves with Ignitor Assembly downward, making sure Tube Burner engages Valve properly. See illustration below.

Secure Tube Burners to Burner Brackets with previously removed Hitch Pins. Replace Carryover tubes and secure with Hitch Pins previously removed. Reference illustration C1.

Reinstall Searing Burner with previously removed Screws, Lock Washers and Flat Washers. Reference illustration C3.

Make sure Searing Burner engages Valve properly. See illustration below.

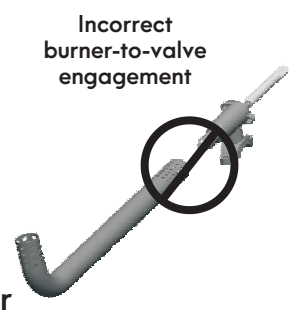
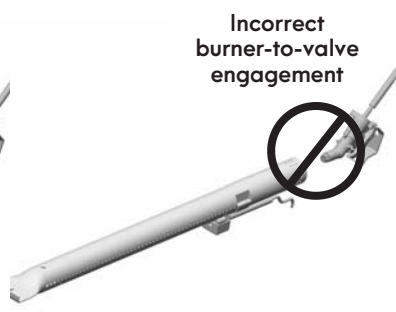
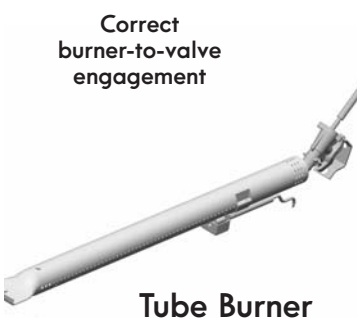

Section D

D1

Remove Screws, Washers, and Nuts that secure Rotisserie Cover to back of grill Firebox.

Remove Rotisserie Cover.

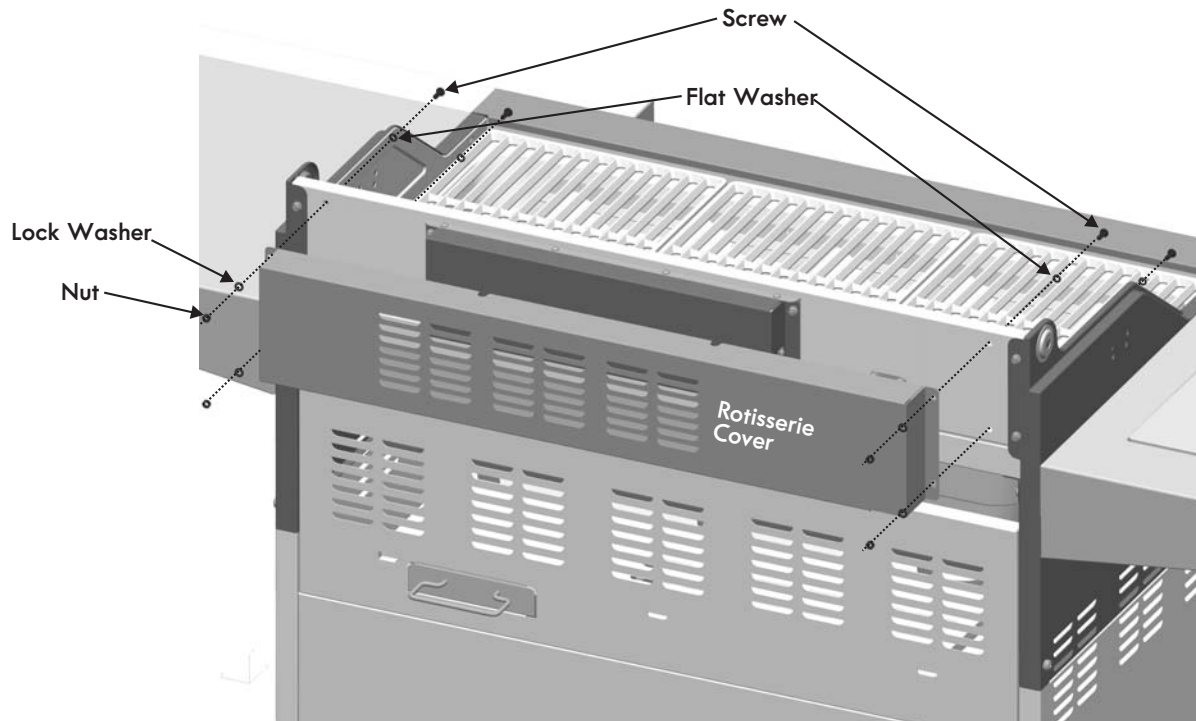

D2

Using a wrench (not provided) remove Securing Nut from Rotisserie Connector. Slide Rotisserie Connector out from Rotisserie Burner Tube

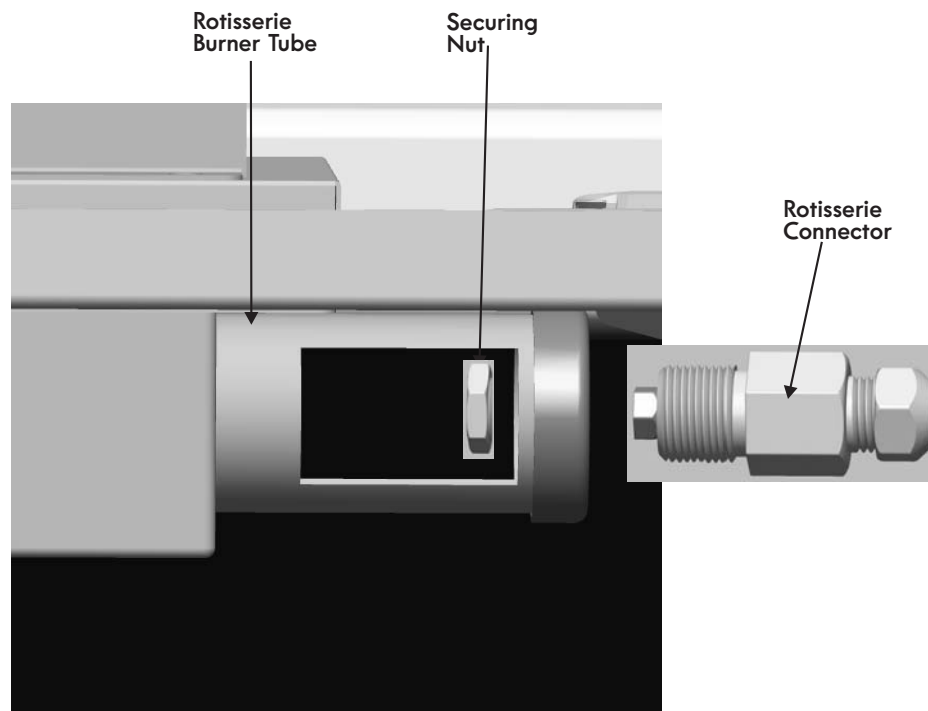

Section D Con't.

D3

Using Orifice Driving Tool provided with Kit, unscrew Orifice from Rotisserie Connector. Save Orifice for converting back to LP Tank Gas. Do not mix with Orifices removed from Main Burners.

For Grill Model 415.16649011 replace with Natural Gas Orifice 1.45mm (Red Dot) and secure tightly to Rotisserie Connector.

For Grill Model 415.16139110 replace with Natural Gas Orifice #53 (Yellow Dot) and secure tightly to Rotisserie Connector.

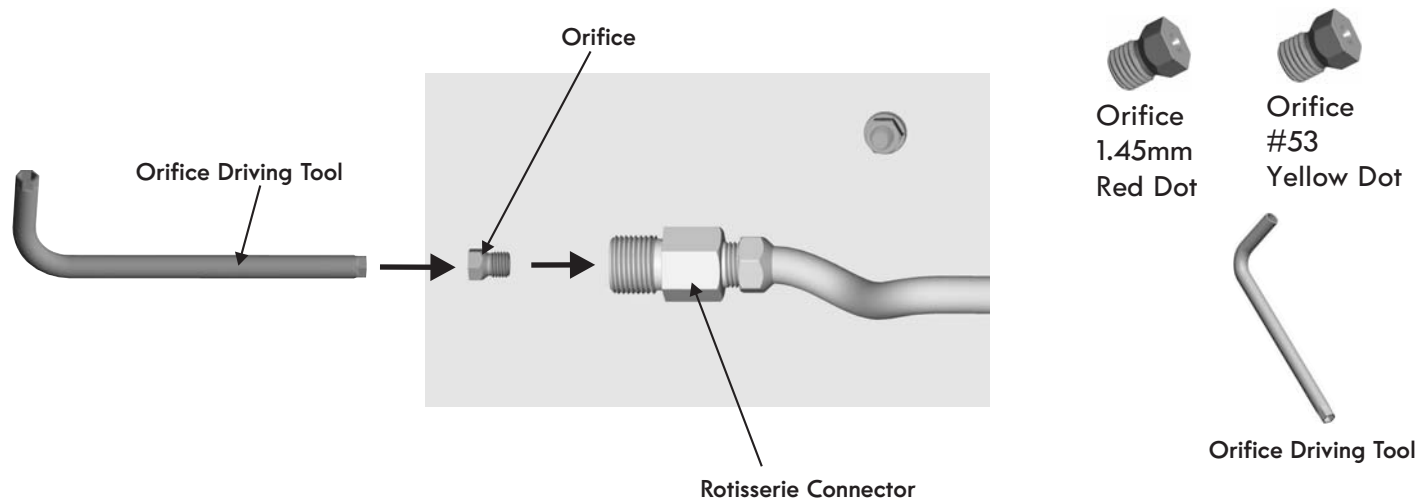

D4

Reinstall Rotisserie Burner

Insert Rotisserie Connector through end of Rotisserie Burner Tube and tighten flush against Burner Tube End Cap using previously removed Securing Nut. Rotisserie Connector with Orifice should engage in Rotisserie Burner Tube. Reference illustration Below.

Replace Rotisserie Cover. Reference illustration D1.

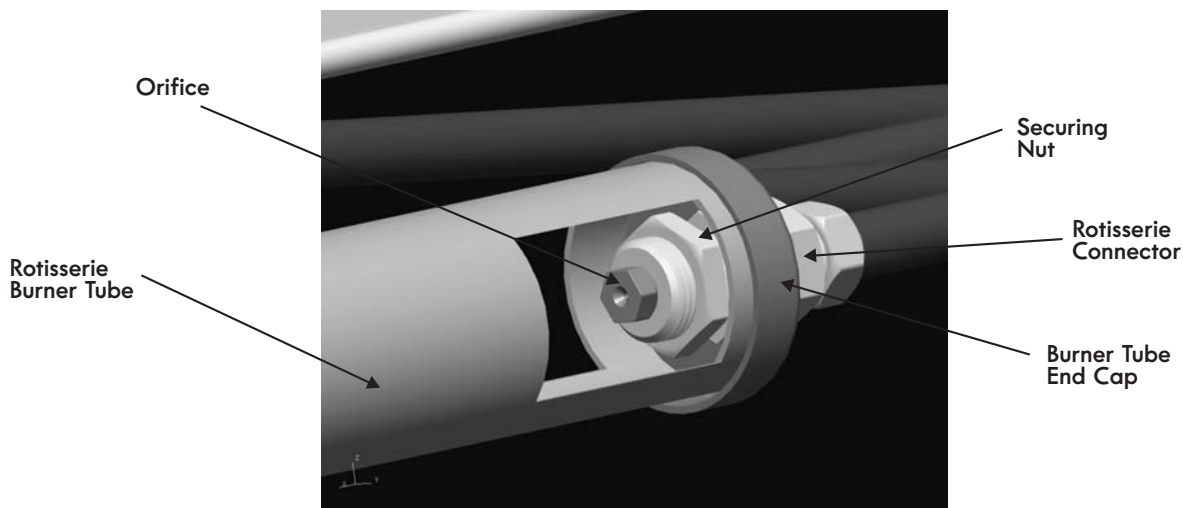

Section D Con't.

D5

Pull the Rotisserie Control Knob off of Valve Stem.

Remove screws and washers that secure Bezel to the Control Panel. Save removed Bezel for converting back to LP Tank Gas.

Install new Natural Gas Bezel provided with Kit (see illustration below) in place of old Bezel onto Control Panel, and secure using previously removed screws and washers. Assure proper alignment with control knob before fully tightening. Note: New bezel will change the rotation for the control knob to properly control ignition and flames for your grill.

Press Control Knob back onto Valve Stem. Make adjustments needed to Bezel for free movement of Control Knob.

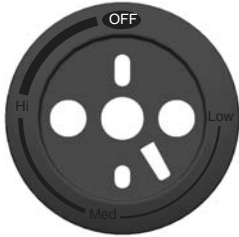

Small Bezel

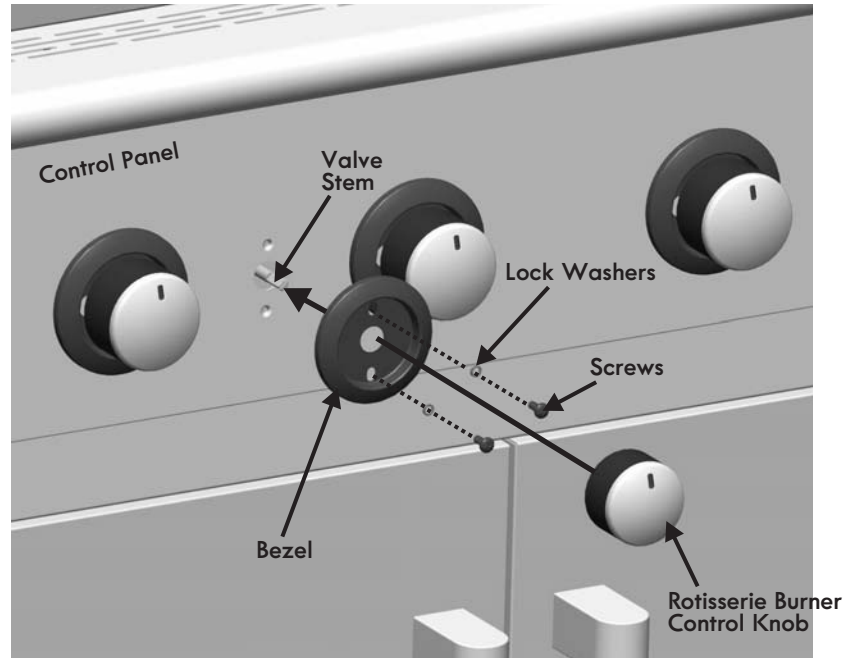

Section E

E1

Open Sideburner Lid and remove the Sideburner Cooking Grate.

Remove Screw from Sideburner Electrode. See illustration below.

Slide Sideburner Electrode out of Collector Box.

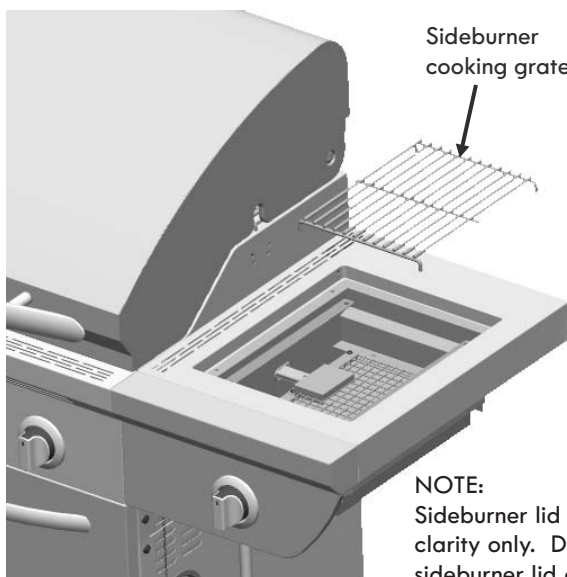

Sideburner cooking grate

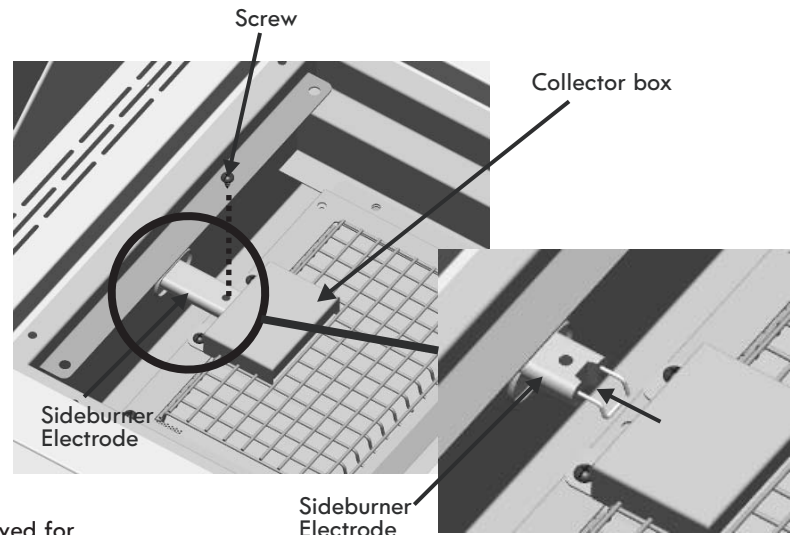

NOTE:
Sideburner lid shown removed for clarity only. Do not remove sideburner lid during conversion.

Sideburner Electrode

Section E Con't.

E2

Remove two Screws at the back of Sideburner.

Remove Sideburner from Shelf.

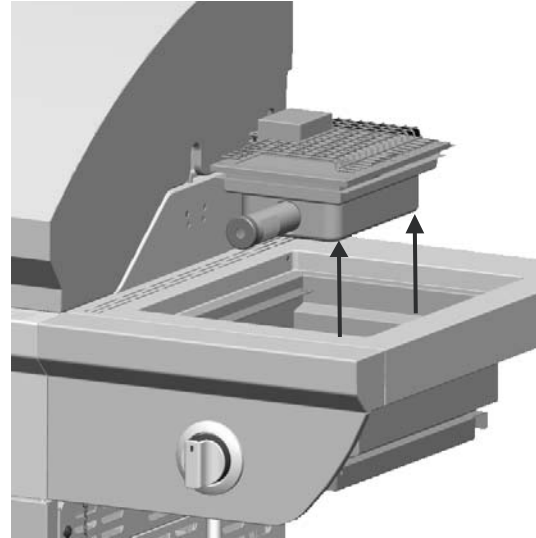
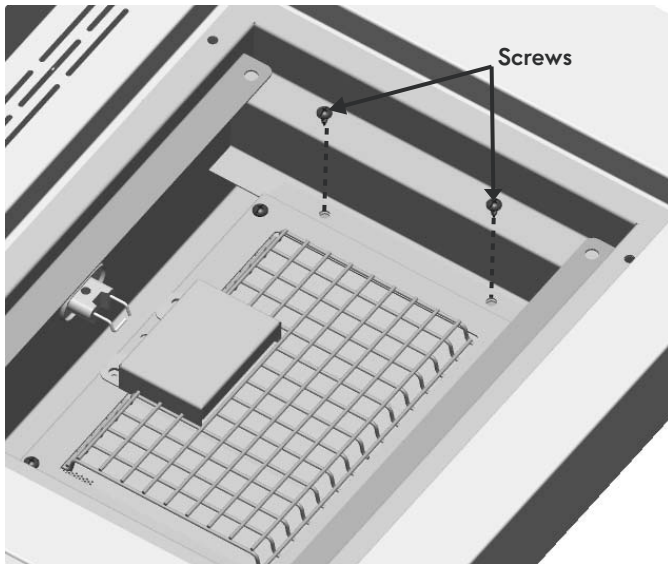

E3

From inside the Shelf unscrew Orifice from end of Sideburner valve using the Orifice Driving Tool provided with kit. Save Orifice for converting back to LP Tank Gas. Do not mix with Orifices removed from Tube Burners.

DO NOT replace the Orifice. This valve is designed to work with Natural Gas once Orifice is removed.

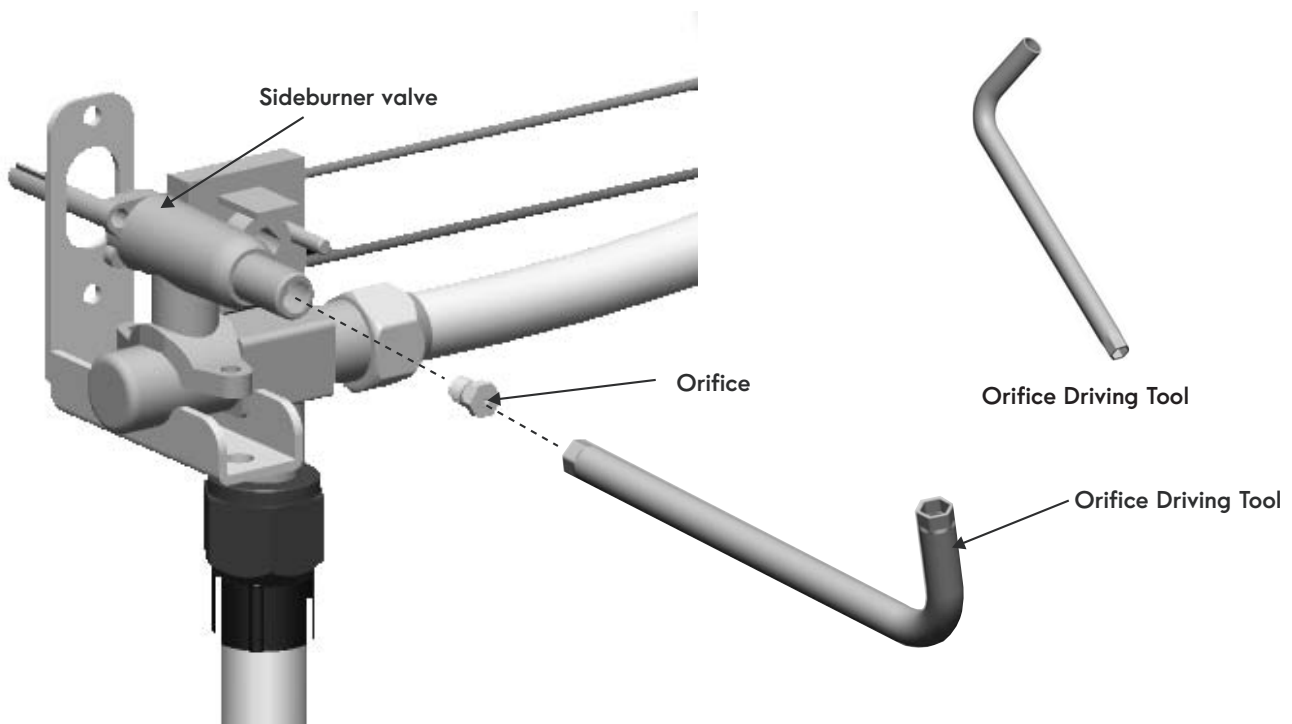

Section E Con't.

E4

Pull the Sideburner Control Knob off of Valve Stem. Remove the existing Bezel by removing the two Screws and two Washers securing Bezel to Shelf fascia. Save removed Bezel for converting back to LP Tank Gas.

Install new Natural Gas Bezel (see illustration below) and press Control Knob back onto Valve Stem.

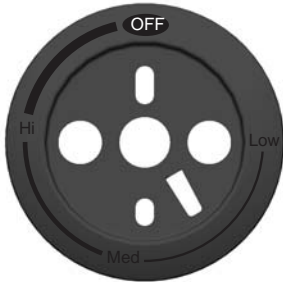

Large Bezel

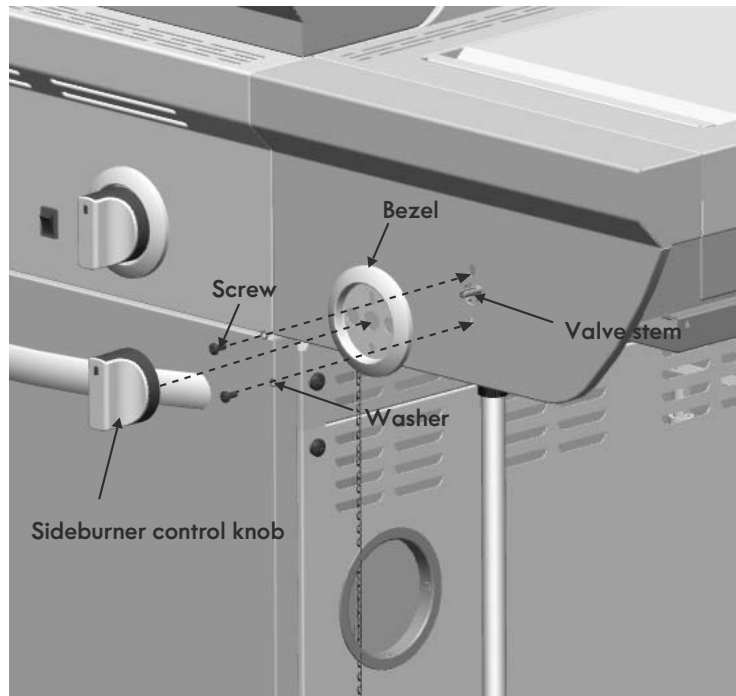

E5

Return sideburner to shelf. Make sure burner engages sideburner valve.

Secure burner to shelf bracket with two screws.

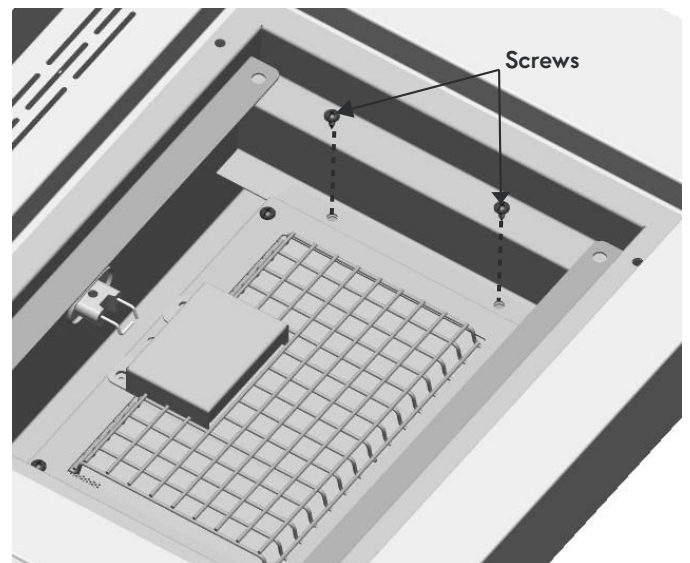
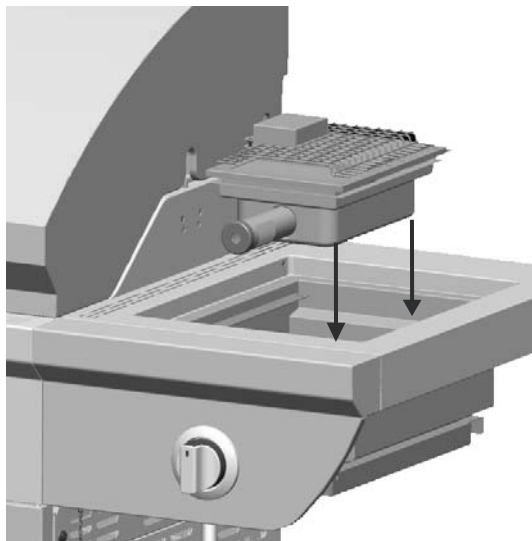

Section E Con't.

E6

Slide Sideburner Electrode into Collector Box.

Secure Sideburner Electrode to Sideburner with Screw.

Replace Sideburner Cooking Grate.

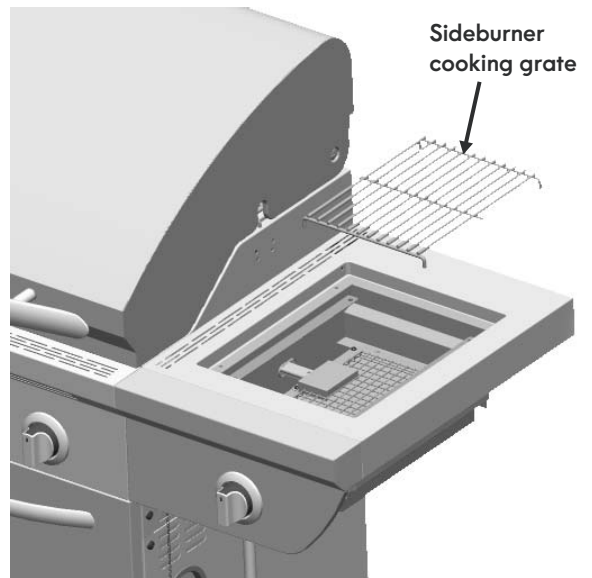
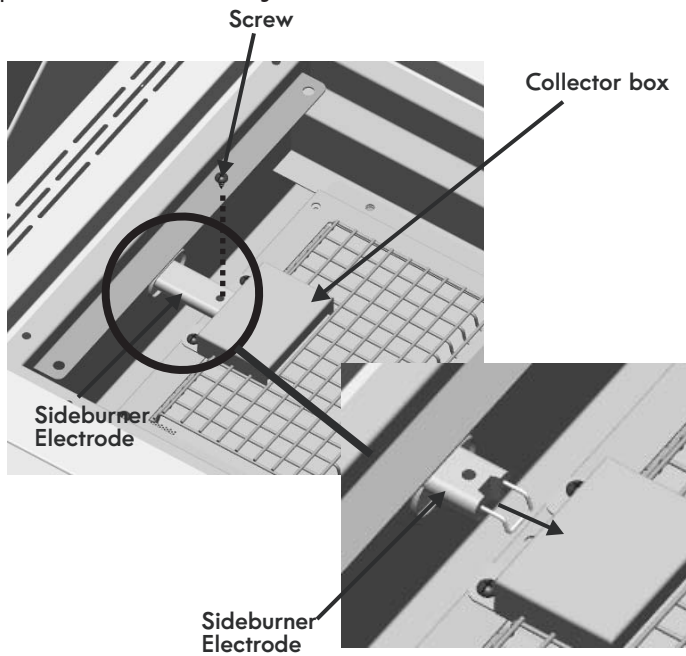

Reinstall Heat Diffusers, Cooking Grates and Warming Rack, reference illustration Section A1. for reinstallation.

Section F

F1

Open Sideburner Lid and remove the Sideburner Grate.

From beneath Sideburner Shelf, remove Wingnut.

Remove Sideburner from Shelf.

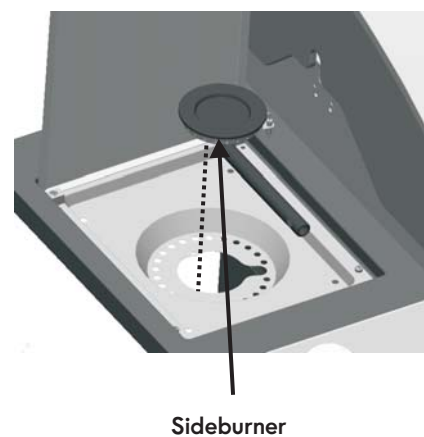
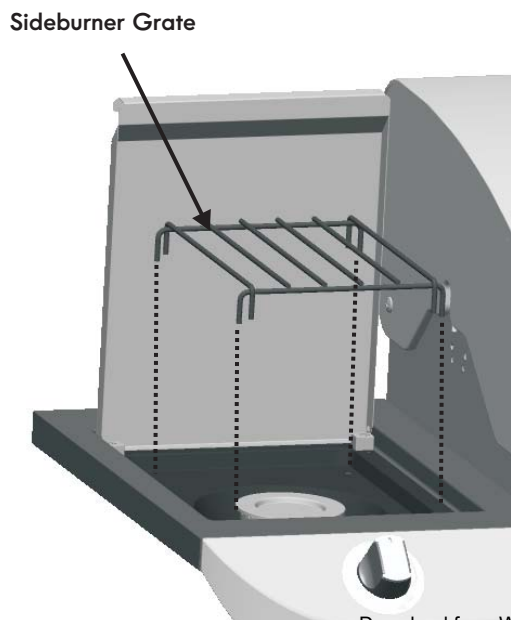

Section F Con't.

F2

Using the provided Orifice Driving Tool, unscrew the Orifice from the end of the Sideburner Valve. Save removed Orifice and Orifice Driving Tool for converting back to LP.

DO NOT replace the Orifice. This Valve is designed to work with Natural Gas once Orifice is removed.

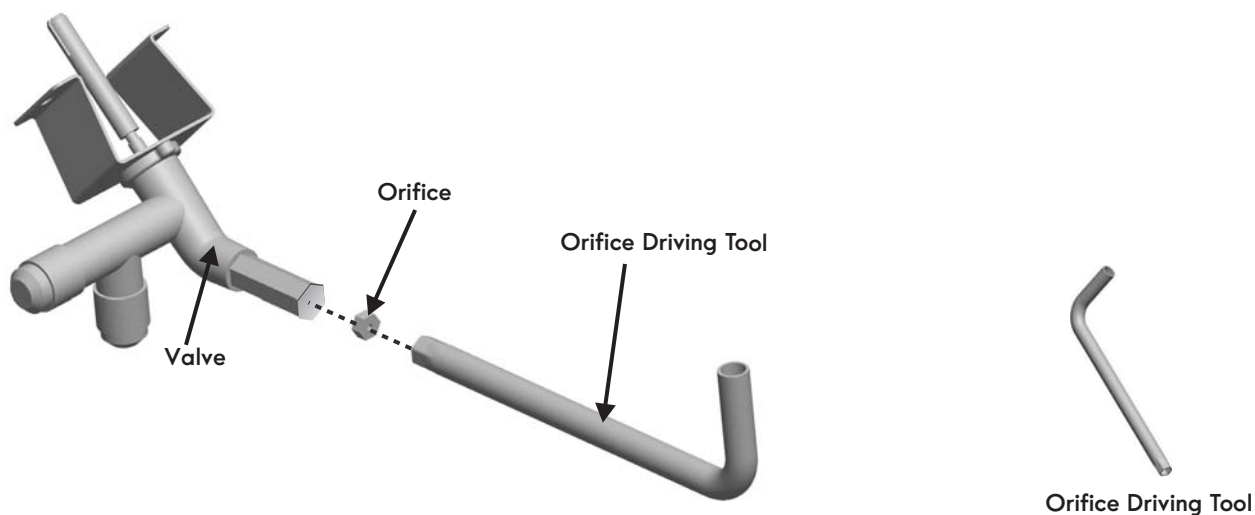

F3

Pull the Sideburner Control Knob off of Valve Stem. Remove the existing Bezel by removing the two Screws and two Washers securing bezel to Shelf fascia. Save removed Bezel for converting back to LP Tank Gas.

Install new Natural Gas Bezel (see illustration below) and press Control Knob back onto Valve Stem.

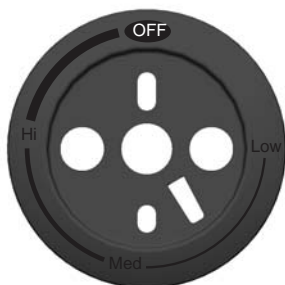

Large Bezel

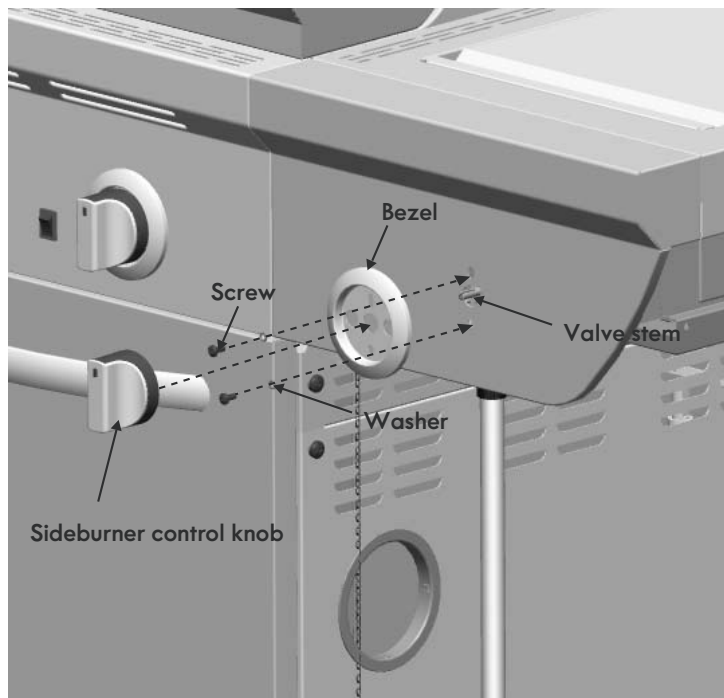

Section F Con't.

F4

Return Sideburner to Shelf. Make sure Burner engages Sideburner Valve. See illustration below for correct burner-to-valve engagement.

Secure Burner to Shelf with Wingnut.

Place Sideburner Grate onto Sideburner Pan.

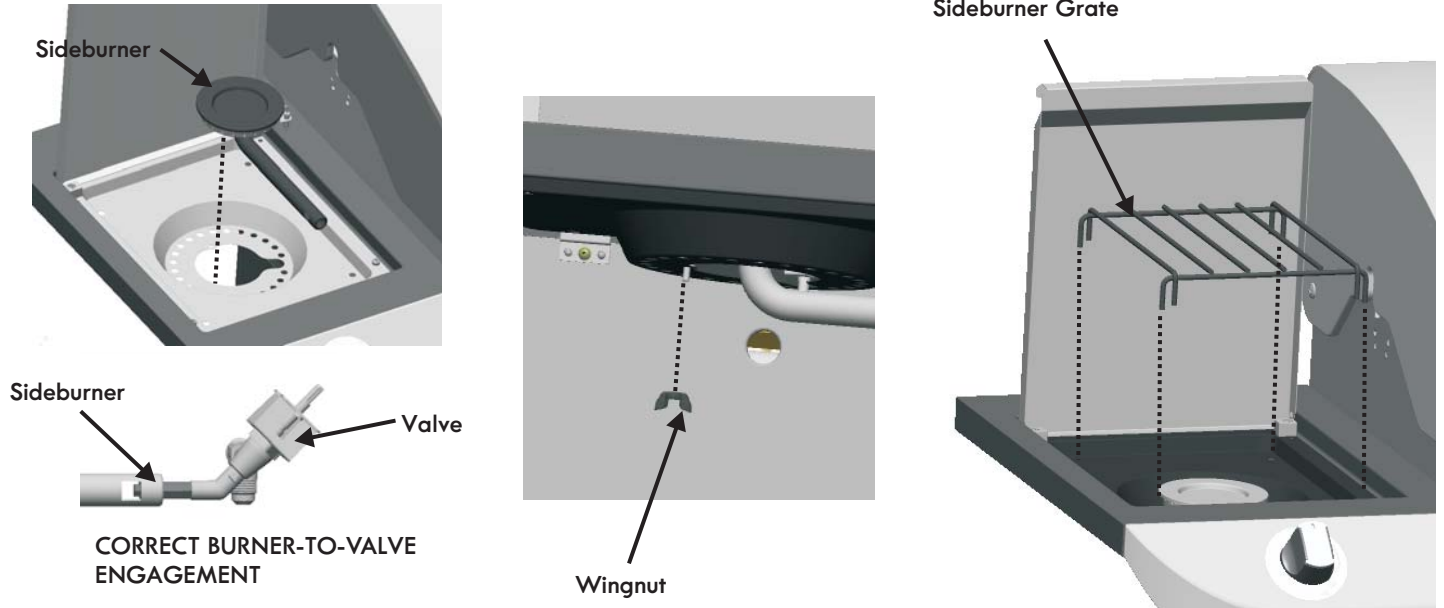

Reinstall Heat Diffusers, Cooking Grates and Warming Rack, reference illustration Section A1. for reinstallation.

Section G

G1

Open Sideburner Lid and remove the Sideburner Grate.

Open Top Drawer below Sideburner. DO NOT REMOVE DRAWER.

Disconnect Ignitor Wire from Electrode.

From beneath Sideburner Shelf, remove two Washers and two Screws.

Remove Sideburner from Shelf.

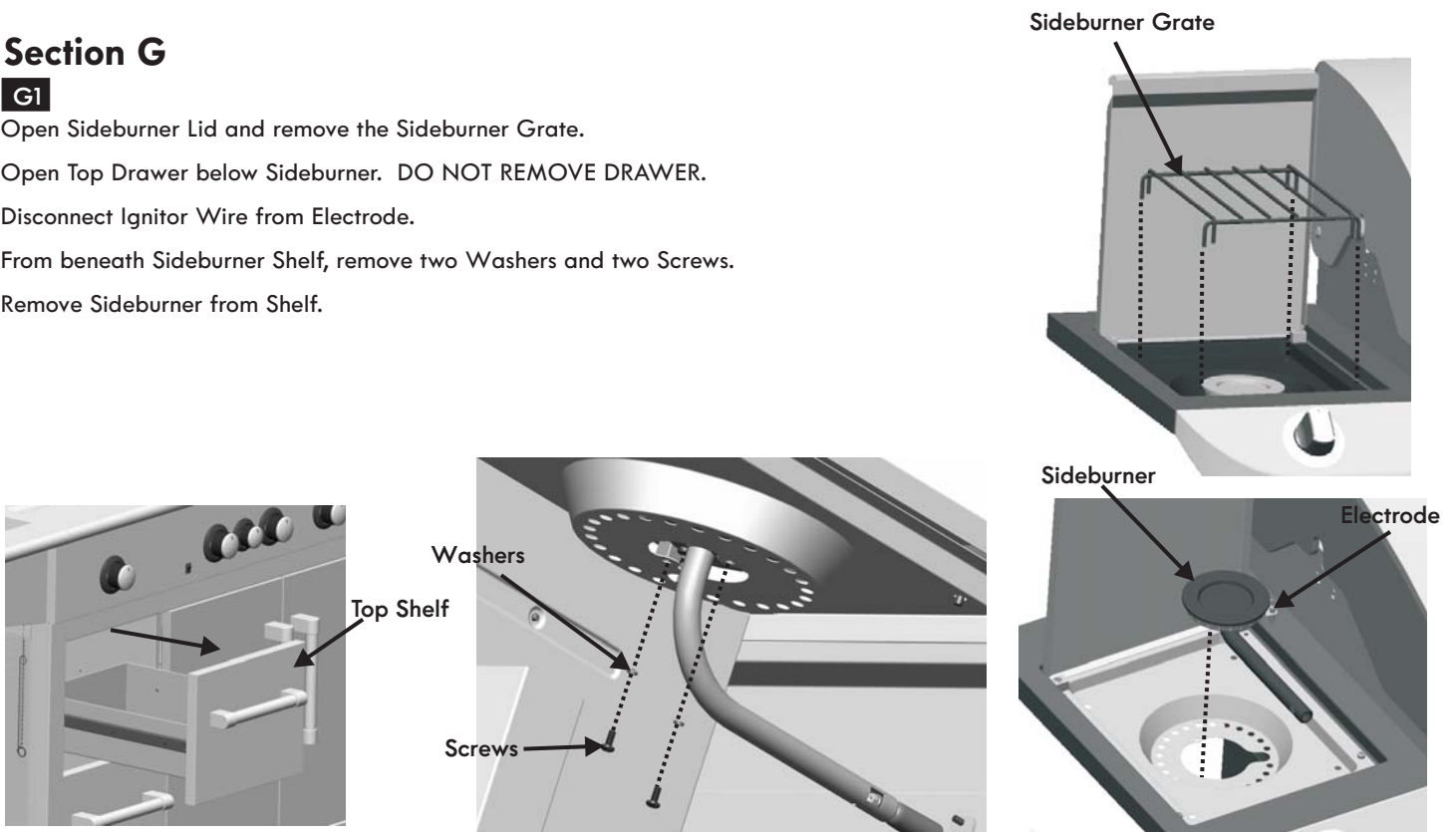

Section G Con't.

G2

Using the provided Orifice Driving Tool, unscrew the Orifice from the end of the Sideburner Valve. Save removed Orifice and Orifice Driving Tool for converting back to LP.

Replace Orifice with Natural Gas Orifice # 53 (Yellow Dot) and secure tightly to Sideburner Valve.

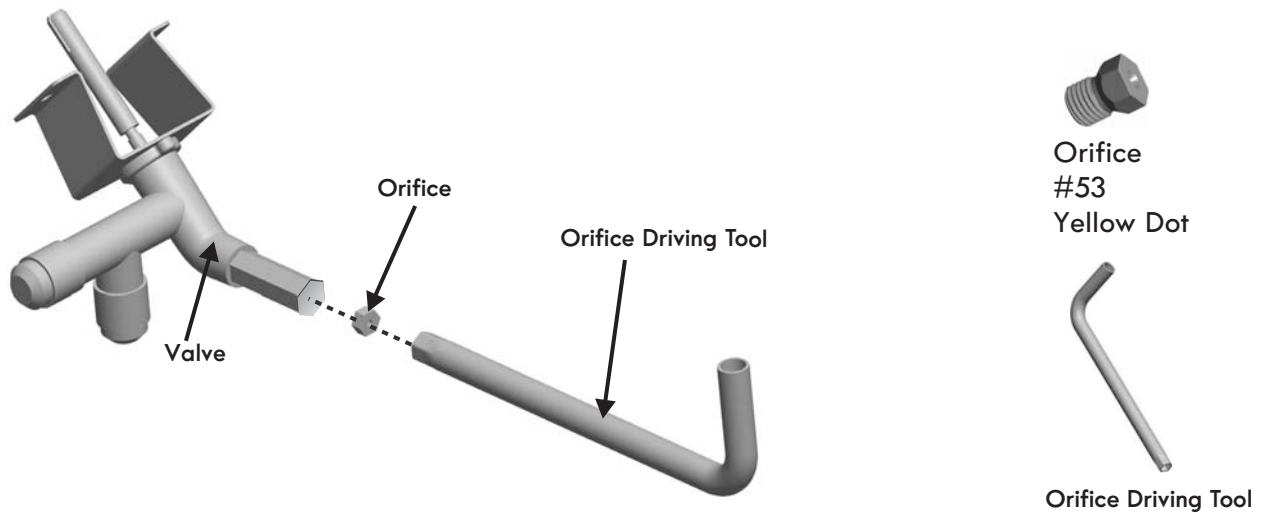

G3

Pull the Sideburner Control Knob off of Valve Stem. Remove the existing Bezel by removing the two Screws and two Washers securing bezel to Shelf fascia. Save removed Bezel for converting back to LP Tank Gas.

Install new Natural Gas Bezel (see illustration below) and press Control Knob back onto Valve Stem.

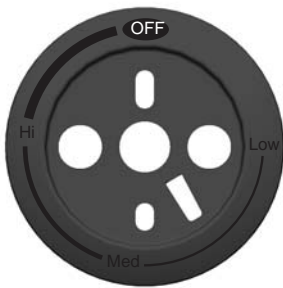

Large Bezel

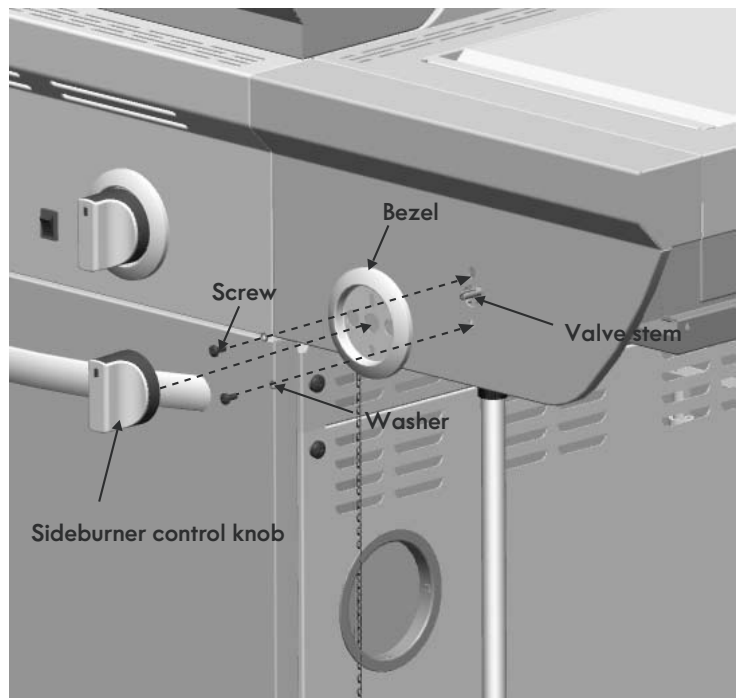

Section G Con't.

G4

Return Sideburner to Shelf. Make sure Burner engages Sideburner Valve. See illustration below for correct burner-to-valve engagement.

Secure Burner to Shelf with two Washers and two Screws.

Reconnect Ignitor wire to Electrode.

Place Sideburner Grate onto Sideburner Pan.

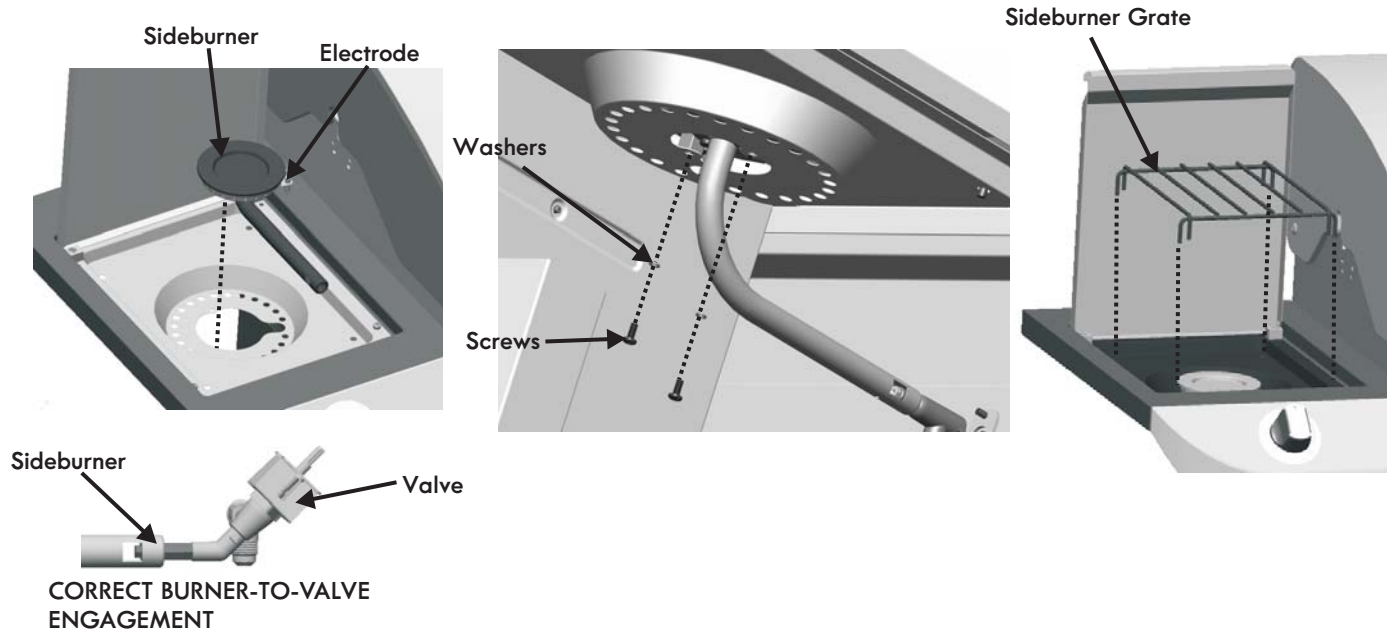

Reinstall Heat Diffusers, Cooking Grates and Warming Rack, reference illustration Section A1. for reinstallation.

TROUBLESHOOTING

EMERGENCIES: If a gas leak cannot be stopped, or a fire occurs due to gas leakage, call the fire department.

Emergencies	Possible Cause	Prevention/Solution
Gas leaking from cracked/cut/burned hose.	<ul style="list-style-type: none"> Damaged hose. 	<ul style="list-style-type: none"> Turn off gas at source. If anything but burned, replace parts. If burned, discontinue use of product until a plumber has investigated cause and corrections are made.

Troubleshooting

Problem	Possible Cause	Prevention/Solution
Burner(s) will not light using ignitor.	GAS ISSUES: <ul style="list-style-type: none"> No gas flow. 	<ul style="list-style-type: none"> Make sure gas hose is properly connected to grill. If hose is properly connected, make sure gas source is turned on.
Burner(s) will not match light.	<ul style="list-style-type: none"> See "GAS ISSUES:" . Match will not reach. Improper method of match-lighting. 	<ul style="list-style-type: none"> Use long-stem match (fireplace match). See "Match-Lighting" section of Grill Use and Care.
Flames blow out.	<ul style="list-style-type: none"> Natural gas valve not fully open. Inadequate gas pressure. 	<ul style="list-style-type: none"> Open Natural Gas Valve to full open position. Call gas company.

This page is intentionally blank

Get it fixed, at your home or ours!

Your Home

For troubleshooting, product manuals and expert advice:



www.managemylife.com

For repair – **in your home** – of **all** major brand appliances, lawn and garden equipment, or heating and cooling systems, **no matter who made it, no matter who sold it!**

For the replacement parts, accessories and owner's manuals that you need to do-it-yourself.

For Sears professional installation of home appliances and items like garage door openers and water heaters.

1-800-4-MY-HOME[®] (1-800-469-4663)

Call anytime, day or night (U.S.A. and Canada)

www.sears.com www.sears.ca

Our Home

For repair of carry-in items like vacuums, lawn equipment, and electronics, call anytime for the location of your nearest

Sears Parts & Repair Service Center

1-800-488-1222 (U.S.A.)

www.sears.com

1-800-469-4663 (Canada)

www.sears.ca

To purchase a protection agreement on a product serviced by Sears:

1-800-827-6655 (U.S.A.)

1-800-361-6665 (Canada)

Para pedir servicio de reparación a domicilio, y para ordenar piezas:

1-888-SU-HOGAR[®]

(1-888-784-6427)

www.sears.com

Au Canada pour service en français:

1-800-LE-FOYER^{MC}

(1-800-533-6937)

www.sears.ca

The Sears logo, featuring the word "Sears" in a large, stylized, serif font with a shadow effect.

Free Manuals Download Website

<http://myh66.com>

<http://usermanuals.us>

<http://www.somanuals.com>

<http://www.4manuals.cc>

<http://www.manual-lib.com>

<http://www.404manual.com>

<http://www.luxmanual.com>

<http://aubethermostatmanual.com>

Golf course search by state

<http://golfingnear.com>

Email search by domain

<http://emailbydomain.com>

Auto manuals search

<http://auto.somanuals.com>

TV manuals search

<http://tv.somanuals.com>