

CHICAGO

Electric[®] Power Tools

3/4 HP DIRTY WATER SUBMERSIBLE PUMP WITH FLOAT

Model 94649

ASSEMBLY AND OPERATING INSTRUCTIONS



Due to continuing improvements, the product shown above may differ slightly from the actual product.



3491 Mission Oaks Blvd., Camarillo, CA 93011
Visit our Web site at <http://www.harborfreight.com>

Copyright © 2006 by Harbor Freight Tools[®]. All rights reserved. No portion of this manual or any artwork contained herein may be reproduced in any shape or form without the express written consent of Harbor Freight Tools.

For technical questions and replacement parts, please call 1-800-444-3353

Specifications

Motor	120 V, 60 Hz, 7 Amp	Min. Water Level	4"
Pump Cord	18 Ft. - 3 Prong Plug	Operating Temp.	95° F
Discharge Size	1-1/2"	Min. Switch Level	3"
Discharge Fittings	1-1/2", 1-1/4" and 1"	Dimensions	6" Dia. x 13-1/2" H
Delivery Height	26.6 Ft.	Housing Material	PP Plastic
Flow Rate	3300 GPH	Pump Weight	10.4 lb.
Horsepower	3/4 HP	Motor Drive	Magnetic Drive
Max. Particle Size	1"		

Warning: The pump should not be submerged in water deeper than the length of the power cord, which is 18 feet long.

Save This Manual

You will need the manual for the safety warnings and precautions, assembly instructions, operating and maintenance procedures, parts list and diagram. Keep your invoice with this manual. Write the invoice number on the inside of the front cover. Keep the manual and invoice in a safe and dry place for future reference.

Safety Warnings and Precautions

WARNING: When using tool, basic safety precautions should always be followed to reduce the risk of personal injury and damage to equipment.

Read all instructions before using this tool!

1. **Avoid pump damage.** Do not operate dry. Never lift or transport the pump by the power cable or float switch cable.
2. **Do not pump certain liquids.** Do not pump gasoline, hydrocarbons, fuel oil, kerosene, fats, salt or waste water, or chemical agents. Do not pump hot liquids.
3. **Avoid fire or explosion.** Do not pump in close proximity to flammable or explosive materials.
4. **Avoid working alone.** If an accident happens, an assistant can bring help.
5. **Avoid electrical shock.** If the submersible pump is to be installed in a location where a breakdown or fault could cause injury to persons, or damage to objects, the power source must utilize a Ground Fault Circuit Interrupter (GFCI). This device will immediately shut down power in case of a short circuit. This device must be tested periodically. No persons should be in contact with the water being pumped.
6. **Keep children away.** Children must never be allowed in the work area. Do not let them handle machines, tools, or extension cords.
7. **Store idle equipment.** When not in use, tools must be stored in a dry location to inhibit rust. Always lock up tools and keep out of reach of children.

8. **Dress properly.** Do not wear loose clothing or jewelry as they can be caught in moving parts. Protective, electrically nonconductive clothes and nonskid footwear are recommended when working. Wear restrictive hair covering to contain long hair.
9. **Use eye and ear protection.** Always wear ANSI approved impact safety goggles.
10. **Do not overreach.** Keep proper footing and balance at all times. Do not reach over or across electrical cables or frames.
11. **Stay alert.** Watch what you are doing, use common sense. Do not operate any tool when you are tired.
12. **Check for damaged parts.** Before using any tool, any part that appears damaged should be carefully checked to determine that it will operate properly and perform its intended function. Check for alignment and binding of moving parts; any broken parts or mounting fixtures; and any other condition that may affect proper operation. Any part that is damaged should be properly repaired or replaced by a qualified technician. Do not use the tool if any switch does not turn On and Off properly.
13. **Replacement parts and accessories.** When servicing, use only identical replacement parts. Use of any other parts will void the warranty. Only use accessories intended for use with this tool. Approved accessories are available from Harbor Freight Tools.
14. **Use proper power outlet.** This pump has a three prong plug. The third prong (round) is the ground. Plug the pump cord only into a three-prong, Ground Fault Circuit Interrupter receptacle. Cutting off the ground prong will result in a safety hazard and void the warranty.
15. **Using Extension Cords.** An extension cord up to 50 feet must have a wire size of 18 AWG; up to 100 feet must have a wire size of 16 AWG. Do not submerge extension cords or make contact with water. **Note: Do not make the extension cord connection underwater.**
16. **Use the right tool for the job.** Do not attempt to force a small tool or attachment to do the work of a larger industrial tool. There are certain applications for which this tool was designed. Do not modify this tool and do not use this tool for a purpose for which it was not intended.
17. **Do not operate tool if under the influence of alcohol or drugs.** Read warning labels on prescriptions to determine if your judgment or reflexes are impaired while taking drugs. If there is any doubt, do not operate the tool.
18. **Pacemaker safety warning.** People with pacemakers should consult with their physician(s) before using this product; operation of equipment in close proximity to a heart pacemaker could cause interference or failure of the pacemaker.

Warning: The warnings, cautions, and instructions discussed in this instruction manual cannot cover all possible conditions and situations that may occur. It must be understood by the operator that common sense and caution are factors which cannot be built into this product, but must be supplied by the operator.

Unpacking

When unpacking, check to make sure all parts are included. Refer to the parts list and assembly diagram on page 7 and 8. If any parts are missing or broken, please call Harbor Freight Tools at the number on the cover of this manual.

Operation

1. Connect drain hose to the Universal Adapter (47) discharge fitting. This hose should be long enough to drain away from the reservoir being pumped. See installation examples on the next page.
2. If the pump needs to be lowered into a pool or other deep reservoir, attach a rope to the pump handle and lower into position. Never suspend the pump from the power cord or discharge pipe.

The pump should rest on a flat, level, and solid foundation. Never operate on earth, clay, sand, or gravel surfaces. Keep the pump inlet opening clear of debris. If the drain piping runs in excess of 10 feet, it is recommended to use a check valve (not included) to prevent back flow. To avoid air locks in the pump, drill an 1/8 inch hole in the piping, between the check valve and the pump. Refer to the illustration on the next page.

Warning: Never use the line cord to carry the pump. Do not run the pump dry. It will increase wear to the unit and cause possible seal damage.

3. Connect the Power Cable to the Ground Fault Interrupter receptacle to begin pumping.

Caution: The Float Switch must be floating in water for the pump to operate. It is meant to shut off intermittently. Do not attempt to manipulate the switch to keep the pump running continuously. Doing so will damage the pump.

Warning: Never allow the power cord or extension cord connection (if used) to come in contact with ground water.

Note: Performance of this pump may vary depending on variations in local line voltage. Extension cord usage may also affect tool performance.

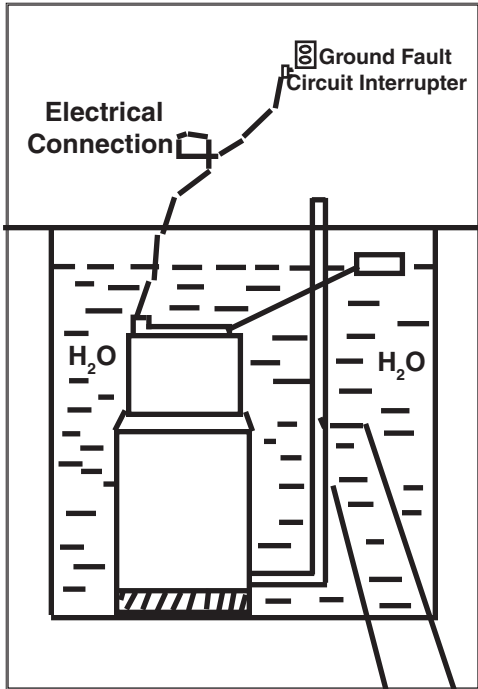

1/8" HOLE
Recommended
Check Valve

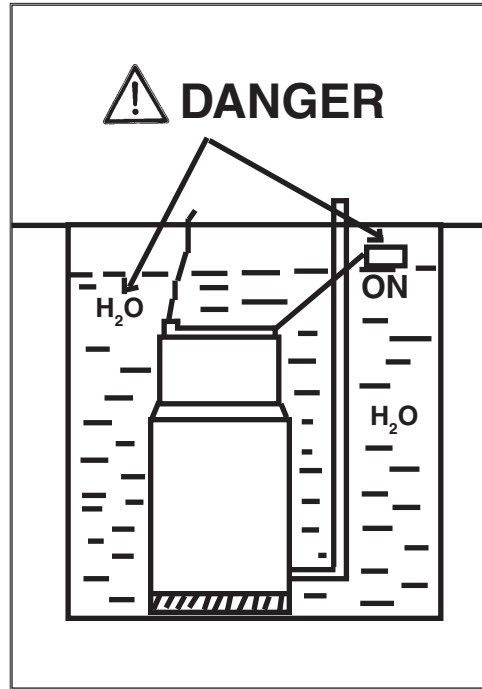

⚠ DANGER Never Touch Float (1)
or Water During Pump Operation

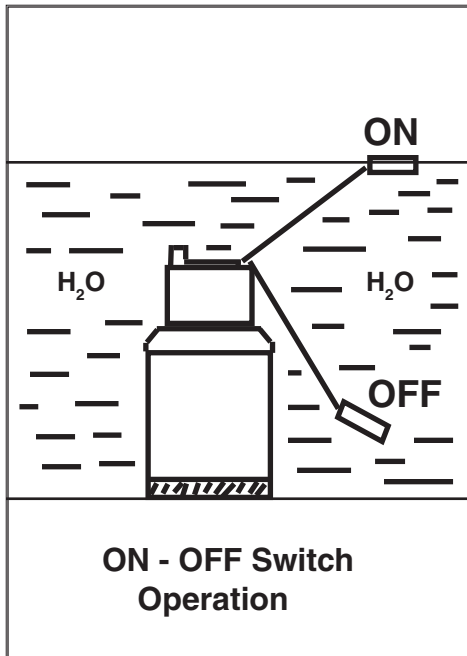

**ON - OFF Switch
Operation**

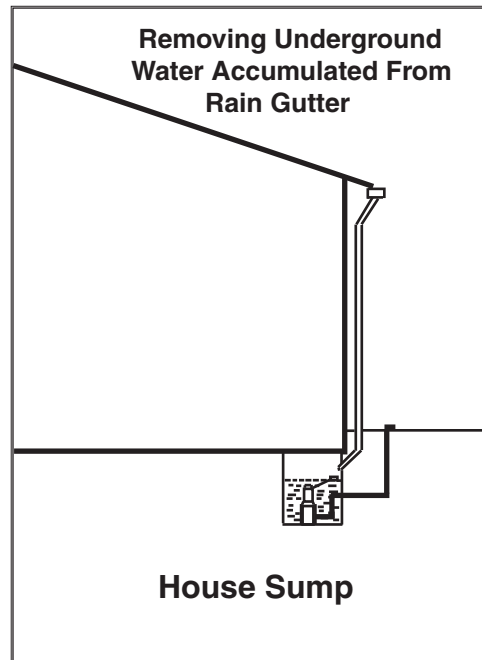

**Removing Underground
Water Accumulated From
Rain Gutter**

House Sump

Troubleshooting

SYMPTOM	CAUSE	SOLUTION
The pump will not start	No power Impeller blocked Thermal protection shutdown Entangled Float Switch	Check power source; Reset GFCI Free impeller (see Maint.) Allow pump to cool down; auto restart Check Float Switch
The pump operates but pumps little or no water	Pump submerged too deep Discharge pipe bent Suction grid clogged Air locked in suction base Optional check valve stuck or installed backwards	Reduce submersion depth Free bends from pipe Clean suction grid Turn off pump for 10 seconds Examine check valve
Excessive noise or vibration	Worn bearings Debris in impeller	Have a qualified technician repair Clean out impeller inlet
Pump starts and stops too frequently	Water temperature too high Defective or entangled Float Switch Water backflow	Never use pump in water over 95 degrees F. Replace or reposition switch Install a check valve at the outlet

Maintenance

Warning: Disconnect power before performing any maintenance.

1. Periodically clean the suction section of the pump, removing any foreign particles. Run in clean water to flush out system.
2. To remove particles stuck on the impeller, remove the screws (19) on the Base Cover (17), and pull Base (18) off.
3. Any other maintenance must be done by a qualified technician.

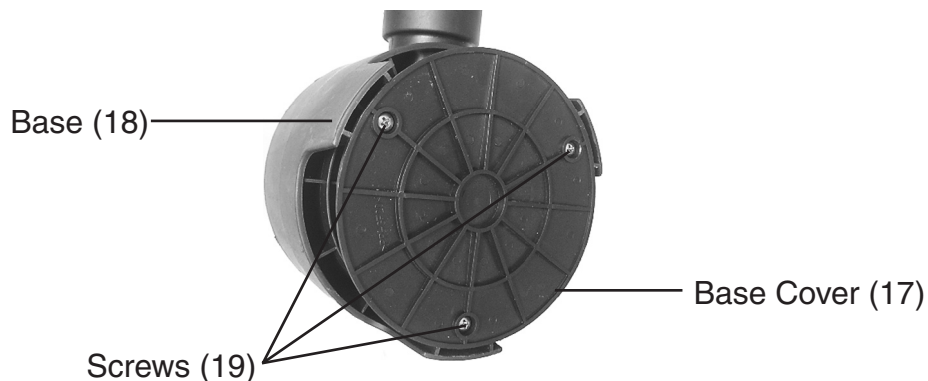

Parts List

Part	Description	Q'ty
1	Float Switch	1
2	Power cable & plug	1
3	Nut	2
4	Plastic handle	1
6	Washer	3
7	Screw	3
8	Outer pump housing	1
9	Screw	1
10	O-ring	2
11	Rear housing motor	2
12	Cord Jacket	1
13	Cord clip	1
14	Cord clip	1
15	Screw	1
16	Condenser	2
17	Base cover	1
18	Base	1
19	Screw	3
20	Nut	1
21	Impeller	1
22	Adjustable washer	1
23	Seal washer	1
24	Locating ring	1

Part	Description	Q'ty
25	Screw	6
26	Press ring	1
27	O-ring	1
28	Skeleton seal	3
29	Front cover	1
30	Front bushing	1
31	Bearing	1
32	Rotor	1
33	Under washer	2
34	Stator	1
35	Spring washer	1
36	Screw	1
37	Earthing wire	1
38	Rear cover	1
39	Washer	1
40	Valve bush	1
41	Ball	1
42	O-ring	1
43	Nut	1
44	O-ring	8
45	Washer	6
46	Screw	5
47	Universal Adapter	1

NOTE: Some parts are listed and shown for illustration purposes only and are not available individually as replacement parts.

Assembly Drawing

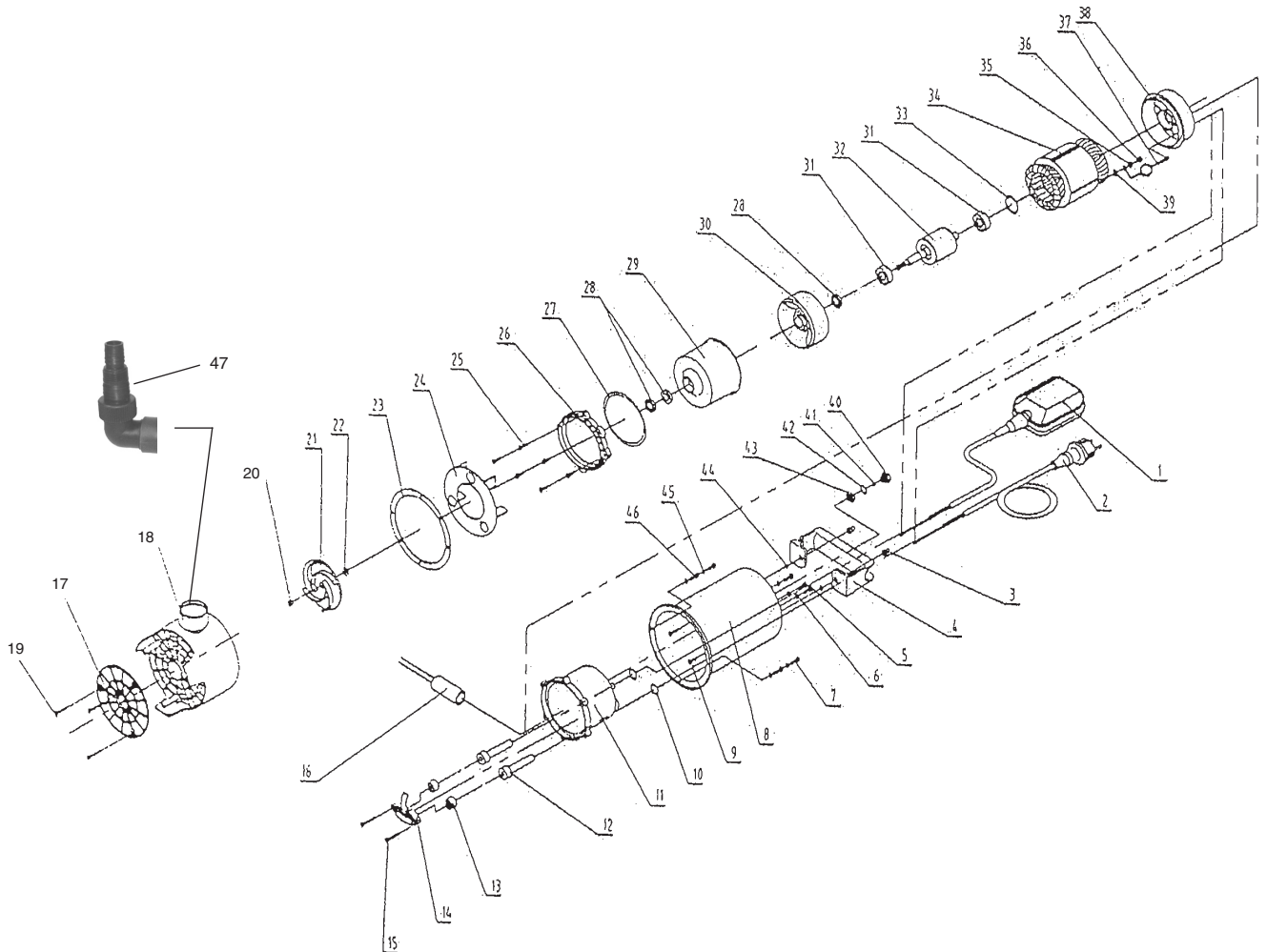

PLEASE READ THE FOLLOWING CAREFULLY

THE MANUFACTURER AND/OR DISTRIBUTOR HAS PROVIDED THE PARTS DIAGRAM IN THIS MANUAL AS A REFERENCE TOOL ONLY. NEITHER THE MANUFACTURER NOR DISTRIBUTOR MAKES ANY REPRESENTATION OR WARRANTY OF ANY KIND TO THE BUYER THAT HE OR SHE IS QUALIFIED TO MAKE ANY REPAIRS TO THE PRODUCT OR THAT HE OR SHE IS QUALIFIED TO REPLACE ANY PARTS OF THE PRODUCT. IN FACT, THE MANUFACTURER AND/OR DISTRIBUTOR EXPRESSLY STATES THAT ALL REPAIRS AND PARTS REPLACEMENTS SHOULD BE UNDERTAKEN BY CERTIFIED AND LICENSED TECHNICIANS AND NOT BY THE BUYER. THE BUYER ASSUMES ALL RISK AND LIABILITY ARISING OUT OF HIS OR HER REPAIRS TO THE ORIGINAL PRODUCT OR REPLACEMENT PARTS THERETO, OR ARISING OUT OF HIS OR HER INSTALLATION OF REPLACEMENT PARTS THERETO.

WARRANTY



CHICAGO
Electric Power Tools

LIMITED 90 DAY WARRANTY

Harbor Freight Tools Co. makes every effort to assure that its products meet high quality and durability standards, and warrants to the original purchaser that this product is free from defects in materials and workmanship for the period of ninety days from the date of purchase. This warranty does not apply to damage due directly or indirectly, to misuse, abuse, negligence or accidents, repairs or alterations outside our facilities, or to lack of maintenance. We shall in no event be liable for death, injuries to persons or property, or for incidental, contingent, special or consequential damages arising from the use of our product. Some states do not allow the exclusion or limitation of incidental or consequential damages, so the above limitation of exclusion may not apply to you. THIS WARRANTY IS EXPRESSLY IN LIEU OF ALL OTHER WARRANTIES, EXPRESS OR IMPLIED, INCLUDING THE WARRANTIES OF MERCHANTABILITY AND FITNESS.

To take advantage of this warranty, the product or part must be returned to us with transportation charges prepaid. Proof of purchase date and an explanation of the complaint must accompany the merchandise. If our inspection verifies the defect, we will either repair or replace the product at our election or we may elect to refund the purchase price if we cannot readily and quickly provide you with a replacement. We will return repaired products at our expense, but if we determine there is no defect, or that the defect resulted from causes not within the scope of our warranty, then you must bear the cost of returning the product.

This warranty gives you specific legal rights and you may also have other rights which vary from state to state.

3491 Mission Oaks Blvd. • PO Box 6009 • Camarillo, CA 93011 • (800) 444-3353

Free Manuals Download Website

<http://myh66.com>

<http://usermanuals.us>

<http://www.somanuals.com>

<http://www.4manuals.cc>

<http://www.manual-lib.com>

<http://www.404manual.com>

<http://www.luxmanual.com>

<http://aubethermostatmanual.com>

Golf course search by state

<http://golfingnear.com>

Email search by domain

<http://emailbydomain.com>

Auto manuals search

<http://auto.somanuals.com>

TV manuals search

<http://tv.somanuals.com>