

Bowflex® TreadClimber® Assembly Guide and Owner's Manual



Special Edition Includes:

**Dr. Ellington Darden's Six Week Fat
Loss-Body Leanness Program:
"Fast Fat Loss Now!"**

TC1000 • TC3000 • TC5000

BOWFLEX
TreadClimber

Preface

CONGRATULATIONS on your commitment to improving your health and fitness! By choosing Bowflex® TreadClimber® exercise machine as your key to success, you will be using the best tool available to help you shed pounds, increase cardiovascular efficiency, and most importantly, look and feel GREAT!

The Bowflex® TreadClimber® machine is an innovative blend of the best features from the three most effective aerobic workout machines available: elliptical, stair climber, and treadmill, which means your results on the TreadClimber® machine will outperform those you can get using any other single aerobic fitness machine!

This three-in-one versatility uniquely targets your muscles and provides you the means to achieve optimum fitness and tone while minimizing the impact of typical workout stressors on your body. Instead of pounding your joints and tendons while jogging, running or cycling, the TreadClimber® machine burns fat while you maintain a walking pace throughout the length of your workout.

This Assembly Guide and Owner's Manual contains Bowflex® TreadClimber® machine workout combinations to build the best calorie-burning, cardiovascular fitness routines for you, and a specialized health program "Fast Fat Loss Now!" by Dr. Ellington Darden.

Combine TreadClimber® workout results with "Fast Fat Loss Now!" to build lifetime health habits and become the healthiest, leanest, fittest YOU ever!

Please take your time to read through the entire Assembly Guide and Owner's Manual before attempting to use your Bowflex® TreadClimber® machine. It's important to understand how to assemble and use the machine and how to best perform each exercise before you actually do so.

With all of the health and fitness choices available today, we understand that finding the best workout equipment can be confusing. Everyone at Nautilus, Inc. would like to congratulate you and thank you for selecting a product into which we have put years of research, innovation, and ingenuity. We are proud to offer you the Bowflex® TreadClimber® machine.

How to Use This Manual

Regular use of the TreadClimber® exercise system is an effective way to develop aerobic fitness while conditioning the major muscles of the lower body. To get the best results and keep your machine in peak operating condition, carefully read and follow the guidelines presented in this manual.



WARNING

THIS SYMBOL APPEARING THROUGHOUT THIS MANUAL MEANS PAY ATTENTION! BE ALERT! YOUR SAFETY IS INVOLVED!

Consult Your Physician Before Starting Any Exercise Program.

Only he or she can determine the exercise program that is appropriate for your particular age and condition. If you have not been exercising or are pregnant or have a heart condition or any physical limitation, failure to consult your physician before engaging in physical exercise, such as using the Bowflex® TreadClimber® exercise machine, could result in serious injury or death. If while using the Bowflex® TreadClimber® exercise machine you have any pain or tightness in your chest, an irregular heart beat, shortness of breath, feel faint, light-headed or dizzy or have any pain or discomfort, STOP and consult your physician immediately.

Table of Contents

Before You Start

TreadClimber® Features	1
TreadClimber® Specifications	2
Important Safety Precautions	3
Emergency Stop Procedures	5
Care of Your TreadClimber® Machine	6

Assembly Guide

Before You Assemble	9
TreadClimber® Parts Reference Guide	10
Hardware and Tool List	13
Assembling Your TreadClimber® Machine	14
Calibration Process (TC3000 and TC5000 only)	24
TreadClimber® Satisfaction Guarantee	27
TreadClimber® Warranty Information	28

Getting Started

Before You Start	32
Select Your Workout Level	33
Adjusting Workout Level Settings	34
Pausing or Stopping	35
TC5000 Features	36
TC3000 Features	39
TC1000 Features	39
Setting English or Metric Measurement Units (TC3000 and TC5000 only)	40
Walking Belts Adjustment	41

TreadClimber® Workout Instructions

Determining Your Fitness Level	42
Treadmill Workout	44
Stair-Stepper Workout	46
TreadClimber® Workout	47

Fat Loss-Body Leanness Program

“Fast Fat Loss Now!” By Dr. Ellington Darden	51
--	----

Repairs/Maintenance

Contacting Customer Service	60
Ordering Replacement Parts	60
TC5000/TC3000 Diagnostics	61
Parts	62
Important Contact Numbers	65

TreadClimber® Features

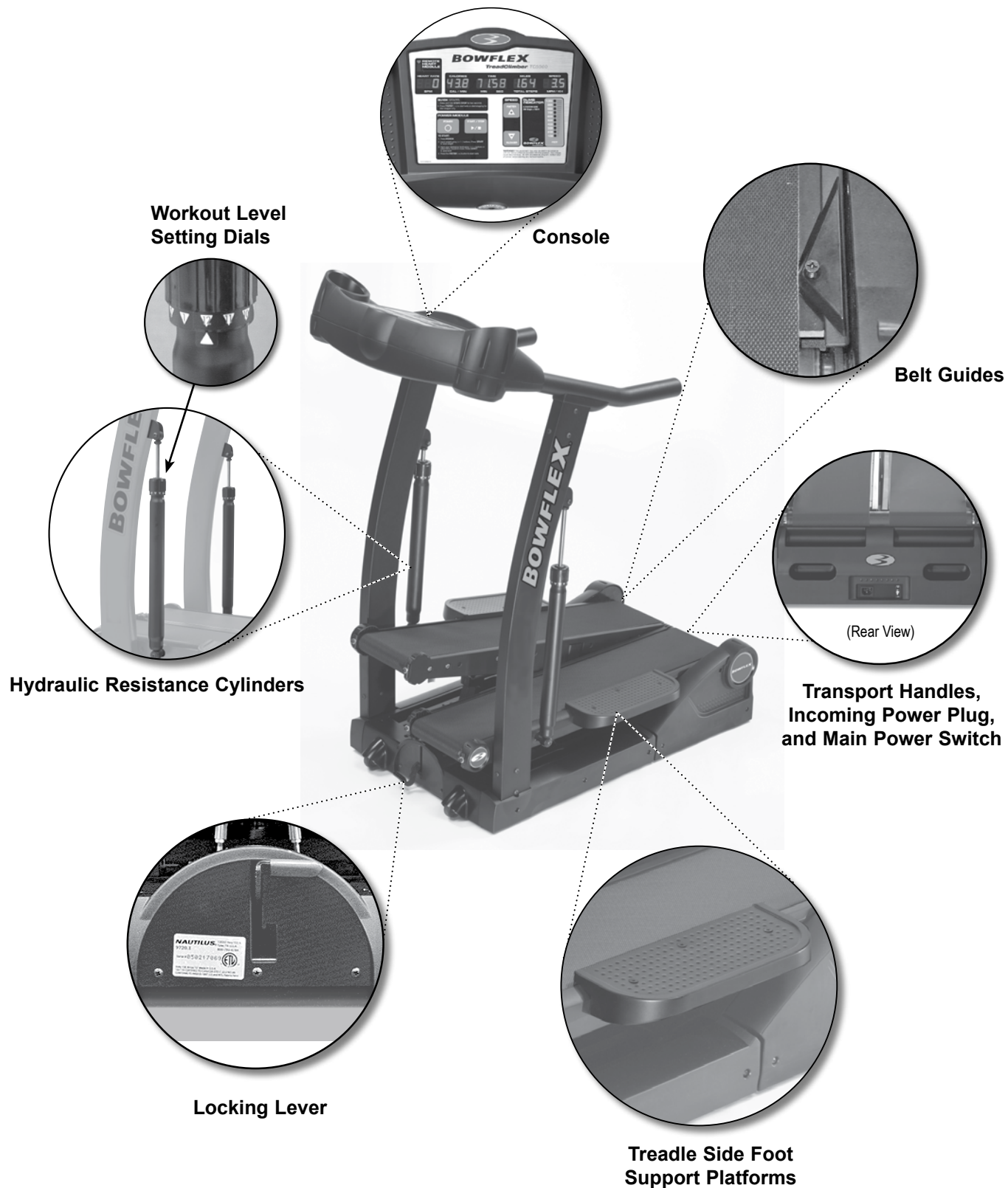

TreadClimber® Specifications

Throughout this manual, all references to the left or right side, and to the front or back, are made as if you were on the TreadClimber® machine, ready to exercise. For example, the power cord is plugged into the incoming power plug at the back of the base.

The dimensions and general specifications for the Bowflex® TreadClimber® exercise machine are as follows:

Physical Dimensions

Length	46 inches (117 cm)
Width	28.5 inches (72.5 cm)
Height	55.25 inches (140.5 cm)
Weight	185 pounds (84 kg)
Shipping Weight	220 pounds (100 kg)

System Capacities

Maximum Weight Capacity	300 lbs (136 kgs)
Speed	
TC1000	0.5 to 3.8 MPH (0.8 to 6.1KPH)
TC3000 and TC5000	0.7 to 4.0 MPH (1.1 to 6.4 KPH)
Workout Resistance Levels	1 to 12
Warranty Length	See the Warranty section for full information per machine type

Component Specifications

Belt	7.75 in x 38.5 in (19.5 cm x 98 cm)
Motor	0.5 hp continuous duty
Treadmill Incline	10% Grade
Frame	Powder-coated steel
Operational Voltage	95 to 130 VAC 50 - 60 Hz
Operational Current	10A Max
Breaker	12A

Always use a 15A circuit with no loads. A short 14 gauge, 3 wire extension cord is permissible.

Regulatory Approvals



Patent Information

U.S. and International Patents Pending



TC1000



TC3000



TC5000

Important Safety Precautions

SAVE THESE INSTRUCTIONS

The following definition applies to the word “Warning” found throughout this manual:

WARNING – Used to call attention to POTENTIAL hazards that could result in personal injury or loss of life.

READ ALL INSTRUCTIONS BEFORE USING THE MACHINE

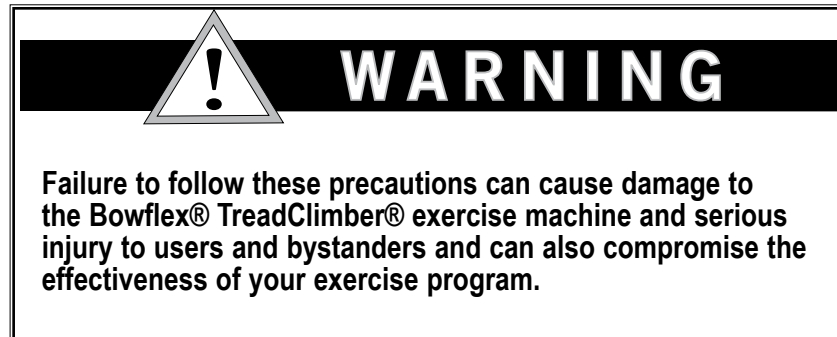

1. Read, understand and carefully follow all warnings, instructions, and procedures on the Bowflex® TreadClimber® exercise machine, and in the Assembly Guide and Owner's Manual before using the TreadClimber® machine. Pay particular attention to and test the Emergency Stop Procedures on Page 5 before use.
2. CONSULT YOUR PHYSICIAN BEFORE STARTING ANY EXERCISE PROGRAM. Only he or she can determine the exercise program that is appropriate for your particular age and condition. If you have not been exercising or are pregnant or have a heart condition or any physical limitation, failure to consult your physician before engaging in physical exercise, such as using the Bowflex® TreadClimber®, could result in serious injury or death. If while using the Bowflex® TreadClimber you have any pain or tightness in your chest, an irregular heart beat, shortness of breath, feel faint, light-headed or dizzy or have any pain or discomfort, STOP and consult your physician immediately.
3. Parents and others in charge of children should be aware that children, because of their natural play instinct and fondness for experimenting, may be tempted to situations and behavior for which the equipment is not intended, with resulting damage to the equipment and injury to the children or others. Children's access to the equipment should therefore be controlled, and they should be instructed about the potential for personal injury and damage if they play with the equipment
4. Inspect the TreadClimber® machine for incorrect, worn, or loose components and then correct, replace, or tighten prior to use. The machine can only be safely used when it is regularly inspected for damage or wear. Inoperable components should be replaced immediately or the equipment taken out of use until it is repaired
5. Be careful when mounting or dismounting the TreadClimber® machine. Do not stand on the Plastic Frame or Drive Covers but always step directly onto the Side Foot Support Platforms. Never step onto the treadles at a high belt speed. Start your workout slowly and gradually increase to your desired workout speed.
6. The maximum speed of the TreadClimber® machine is 4 MPH (6.4 KPH). Do not attempt to run on the TreadClimber® machine, but keep your highest speed at a brisk walk.
7. Do not wear any loose or dangling clothing or jewelry while using the Bowflex® TreadClimber® exercise machine. Always keep your hands, feet, clothing, etc. clear from beneath the treadles and from all moving parts. Never use your TreadClimber® machine with the Plastic Drive or Frame Covers removed.
8. Always wear rubber-soled athletic shoes on the TreadClimber® machine. Never use the TreadClimber® machine barefooted or wearing only socks.
9. Keep your foot centered on each treadle—do not allow your feet to cross in front of your body as you increase speeds.

Important Safety Precautions

10. Keep your hands on the support handlebars and stand as close to the front of the machine as is comfortable in order to remain in balance on the treadles.
11. Never convert from or into treadmill mode while the belts are in motion or the machine is powered up. Turn off power, unplug cord from wall outlet, line up the treadles, and then lock or release the treadle locking lever.
12. Never adjust the Hydraulic Cylinder Workout Settings while belts are in motion. Step completely off of the TreadClimber® machine, stop the belts, and turn the power off prior to adjusting.
13. Maximum user weight for the Bowflex® TreadClimber® exercise machine is 300 pounds (136 kg). For your safety, do not use or allow others to use the Bowflex® TreadClimber® exercise machine if they weigh in excess of 300 pounds (136 kg).
14. Make certain that observers stand clear of the Bowflex® TreadClimber® exercise machine when it is in use. Extra care must be taken when disabled persons or pets are nearby.
15. Never allow children to use the Bowflex® TreadClimber® exercise machine unsupervised. To do so could result in injury. Before children are allowed to use the equipment, their mental and physical development should be taken into account through consultation with their doctor, who must approve any exercise program before a child attempts it. Children should be controlled and instructed on the correct use of the equipment.
16. This equipment is under no circumstances suitable as a children's toy.
17. For safety and security, when the TreadClimber® machine is not in use, always lock the treadles and remove the Safety Key.
18. Locate the TreadClimber® machine on a clean, hard, level surface, free from debris, or other objects that may hamper your ability to move freely. Always use a rubber mat beneath the TreadClimber® machine to ground it, to prevent static electricity discharge and to protect your flooring.
19. Do not use your TreadClimber® machine outdoors, on dirt floors, or in any damp or wet location.
20. Keep the surface of the TreadClimber® machine dry and free from dust or moisture.
21. Use only parts, attachments or accessories that are provided with the TreadClimber® machine.
22. Always connect the power cord to a circuit capable of handling 10 amperes with no other loads. Keep all cords away from heated surfaces.
23. Always unplug the power cord from the wall outlet before removing or installing parts to avoid the risk of electrocution, shock or mechanical injury.
24. Position the power cord alongside the Bowflex® TreadClimber® exercise machine, out of your way when you dismount the machine. Take care to avoid stepping on the power plug. Check cord and plug placement before beginning your workout.
25. Always be gentle when plugging in and unplugging the power cord from the machine base.
26. Never use the power cord if it has a damaged cord or plug, has been immersed in water, or is not working properly. Contact a TreadClimber® Representative to arrange for replacement of a damaged cord.
27. Never drop or insert any object into any opening on the machine.
28. Do not operate where aerosol (spray) products are being used.
29. Do NOT attempt to move the TreadClimber® machine without help, or from the front of the unit. Doing so could cause injury to you or damage the machine.
30. The TreadClimber® machine is intended for individual consumer use only, and is not meant for use by institutions.
31. The warning labels affixed to the TreadClimber® machine contain important information about your safety. Always read and follow the Warning and Safety labels. Do not remove these labels. If at any time the warning labels become loose, unreadable or dislodged, replacements are available by calling a Nautilus Representative.

Emergency Stop Procedures

Your TreadClimber® machine is equipped with a SAFETY KEY that can protect you from serious injury and inhibit children from playing with and/or being injured on the TreadClimber® machine. If the Safety Key is not fully inserted into the safety keyhole, the TreadClimber® machine will NOT power up.

ALWAYS ATTACH THE SAFETY KEY CLIP TO YOUR CLOTHING DURING YOUR WORKOUT.

Always remove the Safety Key from the TreadClimber® machine when not in use to prevent children or other persons from using the machine unsupervised.



Safety Key with Clip



WARNING

REMOVE THE SAFETY KEY WHILE USING THE TREADCLIMBER® MACHINE ONLY IN AN EMERGENCY. WHEN THE KEY IS REMOVED, THE TREADCLIMBER® MACHINE WILL STOP INSTANTLY, WHICH COULD CAUSE SOMEBODY USING THE MACHINE TO LOSE BALANCE OR FALL.

This feature is meant to prevent serious harm and, used properly, is an excellent way to protect your safety during your workout.

Care of your TreadClimber® Exercise Machine

ATTENTION

The Bowflex® TreadClimber® machine's safety and integrity can only be maintained when it is regularly examined for damage and immediately repaired.

It is the sole responsibility of the owner to ensure that regular maintenance is performed. Worn or damaged components still under warranty must be replaced immediately and the TreadClimber® machine shall remain unused until the required repair is made. Only manufacturer-supplied or approved components shall be used to maintain and repair the TreadClimber® machine.

ALWAYS UNPLUG YOUR TREADCLIMBER MACHINE FROM THE OUTLET BEFORE CLEANING OR SERVICING THE UNIT.

Helpful Hints

Read all maintenance instructions thoroughly before beginning work. In some cases, an assistant is required to perform the necessary tasks. All references to the right or left side, and to the front or back are made as if you were on the TreadClimber® machine ready to exercise.

Initial Service

Upon receiving your TreadClimber® machine, use a soft, clean towel to wipe off the dust that may have accumulated during shipping. Your new machine will require minor assembly. Refer to the **Assembly Guide** section of this manual for details.

Accessories

For best performance, we recommend your TreadClimber® machine be placed on a rubber machine (treadmill) mat. Along with reducing noise, a rubber mat will help keep dust and debris away from your TreadClimber® machine's motor and belts, and will reduce static electricity, which could otherwise cause a sudden charge to the TreadClimber® machine's electronic components.

The Bowflex® TreadClimber® Machine Mat is a professional-quality machine mat designed specifically to fit under your Bowflex® TreadClimber® fitness machine and provide added stability. In addition to protecting your floors from scratches and perspiration, the machine mat reduces your TreadClimber® motor's exposure to dust and debris. And it gives your workout area a clean, finished look.

For more information on this accessory and other Bowflex products available from Nautilus, Inc. check out: www.nautilus.com or www.treadclimber.com.

Cleaning

General cleaning of the TreadClimber® machine will prolong the life of your machine and improve performance.

Keep the unit clean by dusting regularly. Be sure to dust the exposed part of the deck on either side of the walking belts and also the side rails.

Clean the top of the belt with a damp, soapy cloth and wipe carefully and thoroughly with a dry cloth. Be careful to keep liquid away from inside the base frame and beneath the belts.

Care of your TreadClimber® Exercise Machine

Walking Belt and Deck Lubrication

The TreadClimber® machine is equipped with a pre-lubricated, low maintenance deck and belt system. Belt friction may affect the function and life of the TreadClimber® machine. For the best results from your TreadClimber® machine, lubricate the treadles periodically with a *silicone lubricant*, using the following instructions:

1. Unplug the TreadClimber® machine completely from the wall outlet, and remove the power cord from the incoming power plug.

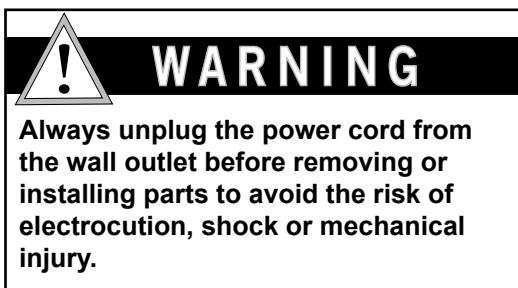

2. While the TreadClimber® machine's treadle surfaces are still warm (not hot), apply a very thin layer of silicone lubricant directly onto the treadle beneath each belt—gently lift each side of the belt and apply a few drops of the lubricant.

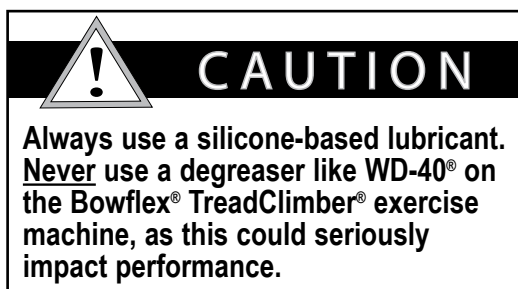

3. Plug the TreadClimber® machine back into the machine base and then into wall outlet.
4. Stand to one side of your TreadClimber® machine on the rubber mat.
5. Turn on your TreadClimber® machine, and start the belts at the slowest speed. Let the belts run for approximately 15 seconds.
6. Turn off your TreadClimber® machine.
7. Take care to wipe up any excess lubricant from the treadles and your rubber floor mat. We also recommend a periodic inspection of the

treadle surfaces under the belts. If the decks appear worn, contact a TreadClimber® Representative at 1-800-NAUTILUS (1-800-628-8458).

NOTE: To reduce the possibility of slipping, be sure the treadle area is free from grease or oil. Wipe off any excess oil from the machine surfaces.

Use the following timetable as a guide to lubricate the decks:

- Light user (fewer than 3 hours/week): annually
- Medium user (3-5 hours/week): every 6 months
- Heavy user (more than 5 hours/week): every three months

We recommend that you use the following:

- Lube-N-Walk® Treadmill Lubrication Kit, available from JAD Fitness, Inc. (800-877-3486 or www.jadfitness.com) or your local specialty fitness dealer.
- 8300 Silicone Spray, available at most Hardware and Auto Parts stores.

Inspecting

1. Visually inspect the TreadClimber® machine every time you use it for wear, damage, or loose parts.
2. Inspect the frame for any rust, bubbling, or paint chips during the weekly cleaning. The salt in perspiration can damage the unpainted surfaces.
3. Inspect the belts for excessive wear during lubrication. Adjust the belt tension if necessary.

Care of your TreadClimber® Exercise Machine

Determining Hours Used (TC3000 and TC5000 models only)

To determine the number of hours you have used your TreadClimber® machine:

1. With the TreadClimber® Main Power Switch turned on, stand on the side foot support platforms.
2. Remove and re-insert the **SAFETY KEY**.
3. The total whole hours used will be displayed in the **TIME** display window. No fractions of, or partial hours will be displayed.
4. The software version will also be displayed in the **MILES** display window.
5. The display will only be visible for 3-5 seconds. Repeat removing and re-inserting the **SAFETY KEY** to view the display again.

Storing Your TreadClimber® Machine

The TreadClimber® machine weighs 185 pounds when fully assembled, and should never be moved or lifted without taking some precautionary care.

There are two handles for lifting on the back of the base and two wheels on either side of the front of the base beneath the console.

The TreadClimber® machine requires 90 pounds of force to lift the base to achieve the 30 degree angle necessary to roll it on the front wheels. As this is a considerable amount of force, it is highly recommended that you do not attempt to ever lift or move the TreadClimber® machine without help.

When lifted properly, your TreadClimber® machine can be rolled on the wheels for storage and/or cleaning. Failure to follow precautions could result in physical injury to you, or damage to the machine, or both.

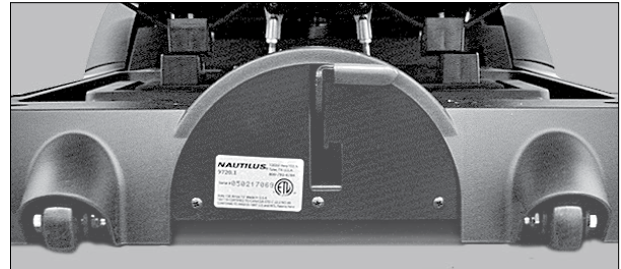

TreadClimber® Base – Front Wheels



TreadClimber® Base – Rear Lift Handles



WARNING

Do not use the uprights, arms, or console to lift or move the TreadClimber® machine. Doing so could cause physical injury to you, and could damage or destroy the TreadClimber® machine.

Assembly Guide

Before You Assemble

Basic Assembly Principals

Here are few basic assembly tips that can make assembly of your Bowflex® TreadClimber® exercise machine quick and easy.

1. You can make the assembly process go faster by gathering the pieces you need for each step prior to starting the step.
2. As a general rule, and for all bolts and locknuts on your Bowflex® TreadClimber® exercise machine, turning toward the right will tighten, turning towards the left will loosen. An easy way to remember this is by remembering the expression, “Lefty loosey, righty tighty.”
3. All of the tools needed for assembly of your Bowflex® TreadClimber® exercise machine have been included. You may find the use of a utility knife or scissors beneficial during the unpacking and assembly process.

Select Your Workout Area

Select where you are going to put your Bowflex® TreadClimber® exercise machine carefully. The best place for your TreadClimber® machine is on a hard, level surface. You will need at least two feet on each side and in front of your TreadClimber® machine, and at least three feet behind it for dismount.

Make sure that the location you choose has a grounded, 3-prong power outlet within reach of the TreadClimber® machine power cord, preferably to the right side of the machine where you will be less likely to step on the cord during dismount.

NOTE: The TreadClimber® machine is designed to plug into a grounded, non-GFI outlets only. To determine if your outlet or circuit breaker is GFI, look for a test and reset button on them. If they have the test and reset button it is a GFI outlet or circuit breaker.

Further, if you ever perform any repairs on your TreadClimber® machine that require you to lay it on its side, you will need at least five feet to one side of your workout area.

Machine Mat

The Bowflex® TreadClimber® Machine Mat is an optional accessory for the TreadClimber® machine that helps keep your workout area free from debris and dust. The rubber machine floor mat provides a non-slip surface for you to use when mounting and dismounting the TreadClimber® machine and limits static discharge when you touch the machine—greatly reducing the possibility of display or running errors. Further, a rubberized mat will protect your flooring when you are performing repairs or maintenance on the TreadClimber® machine.

Put your Bowflex® TreadClimber® Machine Mat in place in your selected workout area before you start assembly to protect your floors and your TreadClimber® machine from damage.

Positioning Your TreadClimber® Machine

Take great care when moving your TreadClimber® machine into place prior to assembly.

There are two handles for lifting on the back of the base and two wheels on either side of the front of the base beneath the console. The TreadClimber® machine requires 90 pounds of force to raise the base the 30 degrees necessary to roll it on the front wheels for storage or cleaning. As this is a considerable amount of force, it is highly recommended that you do not attempt to ever lift or move the TreadClimber® machine without help.

When you assemble the TreadClimber® machine, you will need at least two people to set the base in place, place the treadles, and lift the handlebar assembly.



**TreadClimber® Base -
Rear Lift Handles**

TreadClimber® Parts Reference Guide

Box 1 contains:

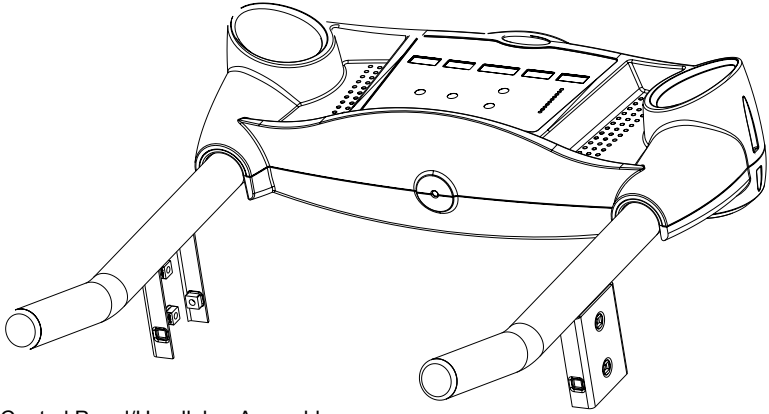
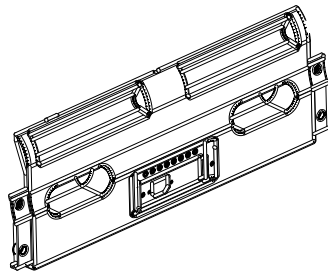
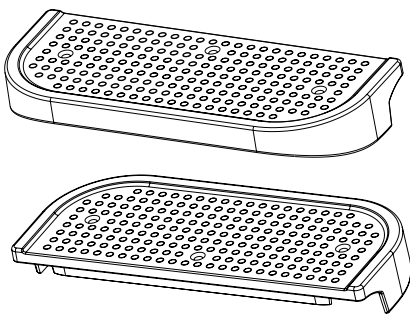
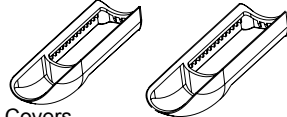
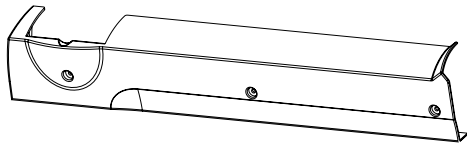
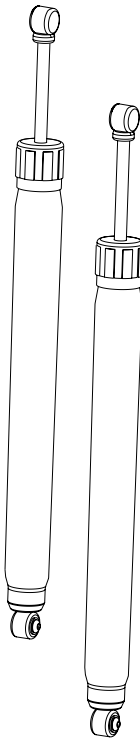
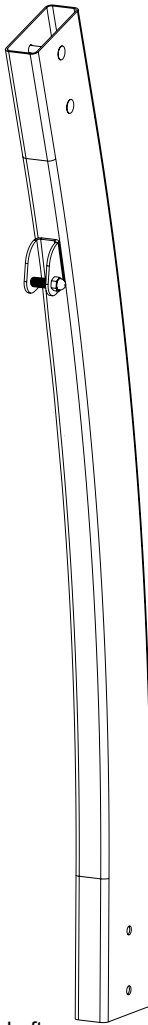
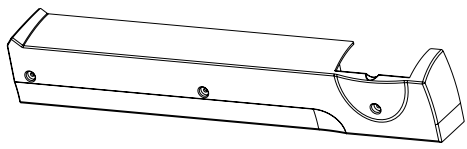
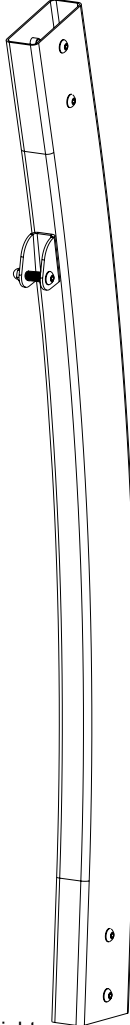
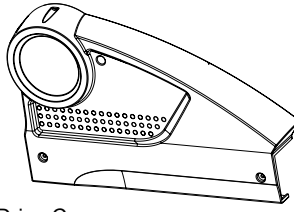
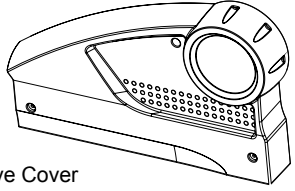
 <p>Qty: 1 Descr: Control Panel/Handlebar Assembly</p>	 <p>Qty: 1 Descr: Rear Cover</p>	
 <p>Qty: 2 Descr: Left and Right Side Foot Support Platform</p>	 <p>Qty: 2 Descr: Plastic Upright Junction Covers</p>	
 <p>Qty: 1 Descr: Left Side Plastic Frame Cover</p>	 <p>Qty: 2 Descr: Left & Right Hydraulic Cylinder</p>	 <p>Qty: 1 Descr: Left Upright Support</p>
 <p>Qty: 1 Descr: Right Side Plastic Frame Cover</p>	 <p>Qty: 1 Descr: Right Upright Support</p>	
 <p>Qty: 1 Descr: Right Side Plastic Drive Cover</p>		
 <p>Qty: 1 Descr: Left Side Plastic Drive Cover</p>		

TreadClimber® Parts Reference Guide



BOX 1 also contains:

Qty: 1

Descr: OWNER'S MANUAL BAG contains the following:

- The Bowflex® TreadClimber® Assembly Guide and Owner's Manual
- (1) Drive Belt
- Power Cord
- (2) Treadle Decals
- (2) Drive Cover Decals
- TreadClimber® Safety Key *Note: TC1000 Safety Key plugged into console.
- Heart Rate Monitor Chest Strap (TC5000 Only)
- (1) #2 Phillips Screw Driver

Qty: 1

Descr: ASSEMBLY HARDWARE BAG contains the following:

- (1) #2 Phillips Screwdriver
- (1) 3/16" Hex Key
- (1) 5/32" Hex Key
- (1) 9/16" Open End Wrench
- (6) 1/4" x 1" Flat Head Screw
- (2) 5/16" Flat Washers
- (14) 5/16" x 1" Button Head Screw
- (2) 5/16" x 1 1/2" Button Head Screw
- (12) 5/16" Flat Washers SAE (smaller O.D.)
- (2) 5/16" Acorn Nut
- (1) 3/8" x 3 3/4" Shoulder Bolt
- (1) 5/16" Nylock Nut
- (4) 3/8" Cosmetic Plugs
- (16) #10 Phillips Head Screws

NOTE: Occasionally extra parts are included.

**If there are any missing parts when you unpack your TreadClimber® machine, please call a TreadClimber® Representative at
1-800-NAUTILUS (1-800-628-8458).**

TreadClimber® Parts Reference Guide

Box 2 contains the TreadClimber® treadles.

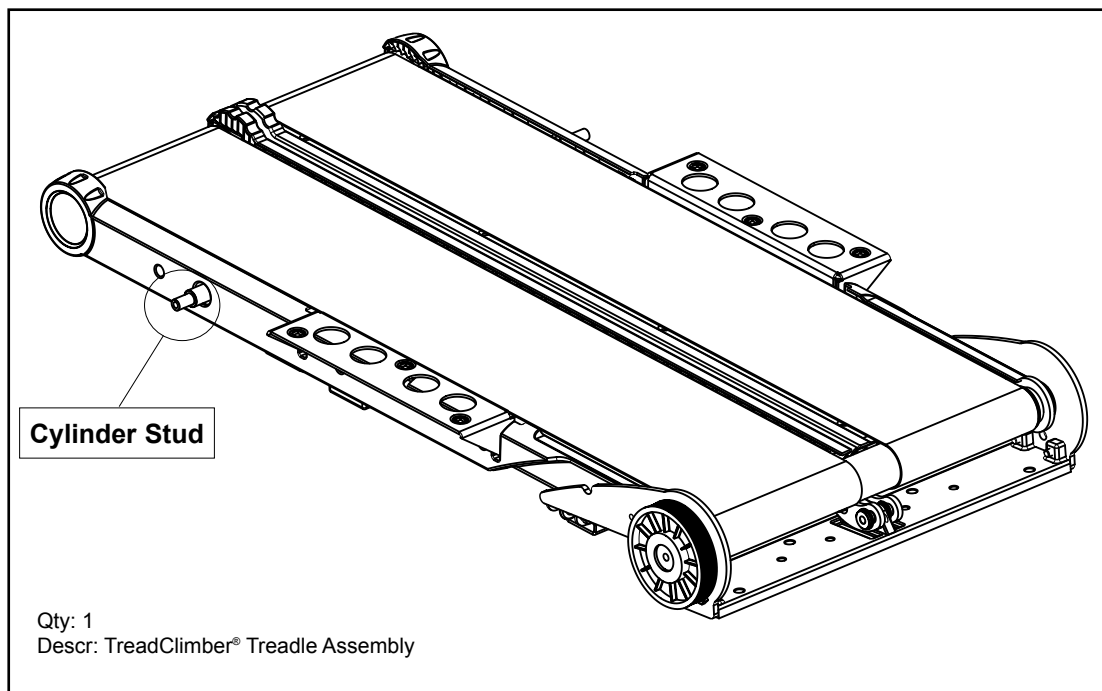



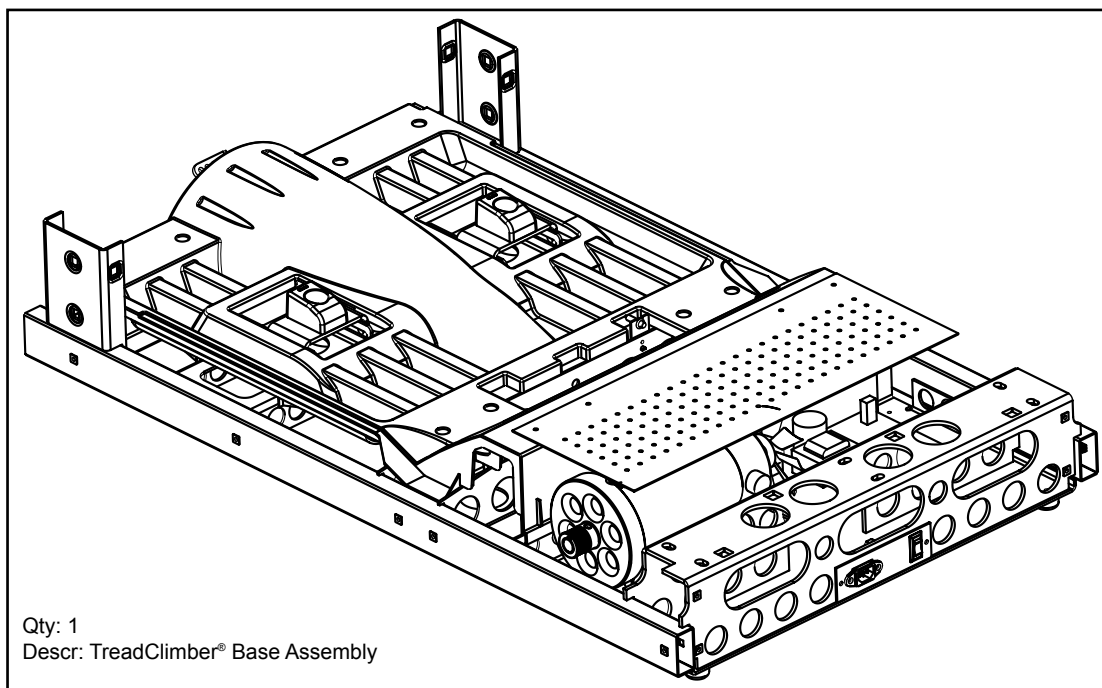

Box 3 contains the TreadClimber® base.





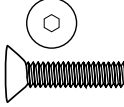
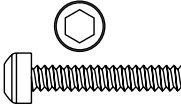
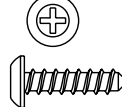
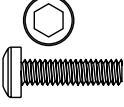
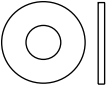

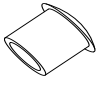
TreadClimber® Hardware and Tool List

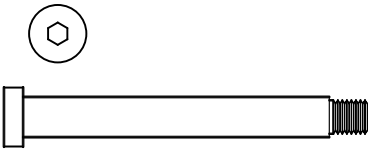
NOTE: IMAGES BELOW ARE NOT TO SCALE

Hardware:

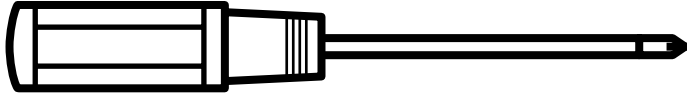
 Qty: 6 Descr: 1/4" x 1" Flat Head Screw	 Qty: 2 Descr: 5/16" x 1 1/2" Button Head Screw	 Qty: 16 Descr: #10 Phillips Head Screw
 Qty: 14 Descr: 5/16" x 1" Button Head Screw	 Qty: 2 Descr: 5/16" Flat Washer	 Qty: 12 Descr: 5/16" Flat Washer SAE
 Qty: 4 Descr: 3/8" Cosmetic Plugs	 Qty: 1 Descr: 5/16" Nylock Nut	 Qty: 2 Descr: 5/16" Acorn Nut
 Qty: 1 Descr: 3/8" x 3 3/4" Shoulder Bolt		

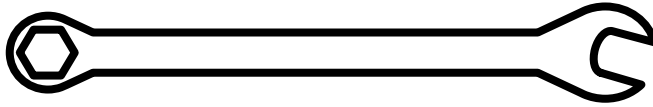
Tools:

 Qty: 1 Descr: #2 Phillips Screwdriver	 Qty: 1 Descr: 3/16" Hex Key
 Qty: 1 Descr: 9/16" Open End Wrench	 Qty: 1 Descr: 5/32" Hex Key

Parts:

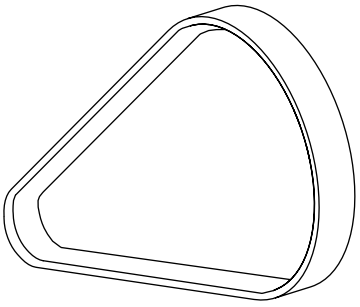
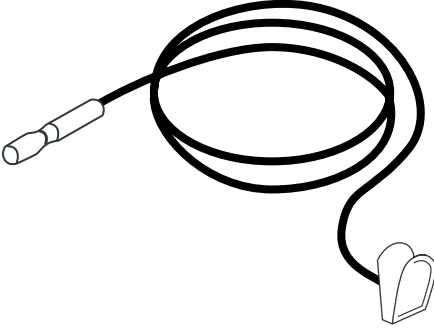
 Qty: 1 Descr: Drive Belt	 Qty: 1 Descr: Safety Key with Clip (Models TC3000 & TC5000 only.)
--	--

Assembly Guide

Assembly Instructions

Step 1: PLACING TREADLES ON BASE

Locate the following for this step:

PARTS:

- TreadClimber® Base Assembly
- TreadClimber® Treadle Assembly

HARDWARE:

- Four (4) 3/8" x 1-1/4" Hex Bolts

TOOLS:

- 9/16" Open End Wrench (included)
- Scissors or other cutting tool

1-1 Place the latch lever on the base in the unlocked position (see Figure 1-1).

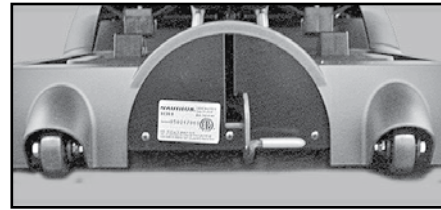

Figure 1-1

1-2 Cut the wire ties on the teeter assembly and extend the teeter to the center of the treadles (see Figure 1-2).

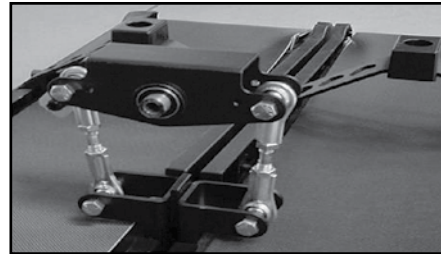

Figure 1-2

1-3 With the help of another, carefully rotate the treadle assembly so the teeter is hanging downward above the base. Slowly lower treadle assembly onto base. Make sure teeter mechanism passes freely through hole in the center of base (see Figure 1-3). Carefully align roller casting so it lays flush on the base (see Figure 1-4). For TC3000 and TC5000 models verify that the step sensor is properly aligned (see Figure 1-3). For all TreadClimber® machines center the treadles, using the orange

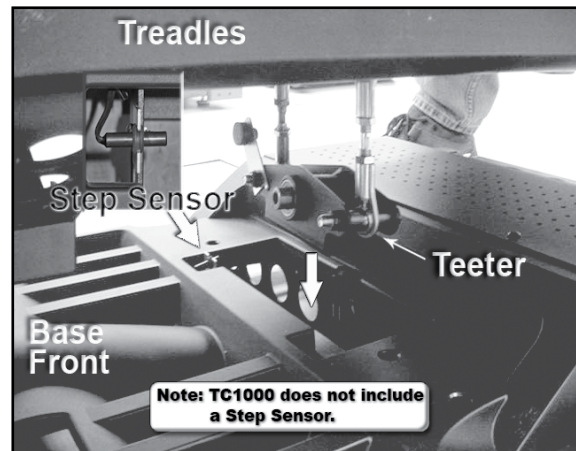

Figure 1-3

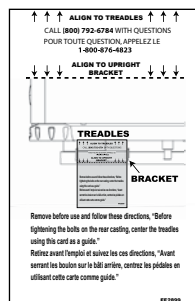

Illustration 1-A

treadle alignment card (see Illustration 1-A), before proceeding.

1-4 Using the 9/16" open end wrench, tighten the (4) 3/8" x 1-1/4" hex bolts on the rear roller casting to bring the casting and base snugly together (see Figure 1-5).

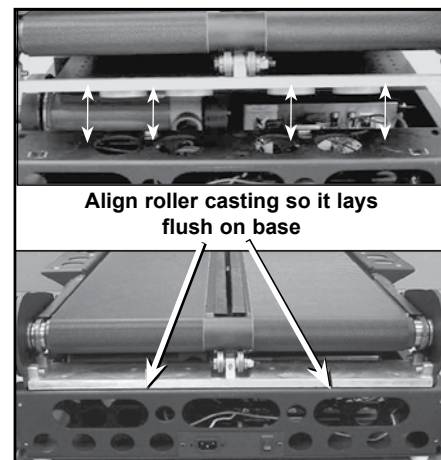

Figure 1-4



Figure 1-5

Assembly Guide

Step 2: CONNECTING SPEED PICKUP WIRE

Locate the following for this step:

PARTS:

- TreadClimber® Base & Treadle Assembly from Step 1.

2-1 Connect the speed pickup wire from base assembly and left rear roller casting (see Figure 2-1 & 2-2).



NOTE: Speed pickup needs to be about 1/8" from the pulley and the red speed pickup cap is flush to the left drive bracket/roller casting.

Speed pickup wire from base.

Speed pickup wire from left rear roller casting.

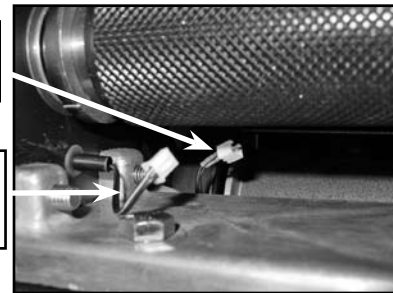

Figure 2-1



Figure 2-2

Step 3: ATTACHING TEETER

Locate the following for this step:

PARTS:

- TreadClimber® Base & Treadle Assembly from Step 2.

HARDWARE:

- One (1) 3/8" x 3-3/4" Shoulder Bolt
- One (1) 5/16" Nylock Nut

TOOLS:

- 3/16" Hex Key (included)
- 9/16" Open End Wrench (included)
- Scissors or other cutting tool

3-1 Carefully set unit up on its right side. This will have the pulley side up and expose underneath side of unit (see Figure 3-1).

3-2 Using the 3/8" x 3-3/4" shoulder bolt and 5/16" nylock nut attach the teeter assembly to base frame (see Figure 3-2). Tighten using the 3/16" hex key and 9/16" open end wrench (see Figure 3-3).

3-3 Cut wire tie from teeter stop brackets.



NOTE: Manipulation of the teeter and or treadles may need to occur to line up all the holes.



Figure 3-1



Figure 3-2

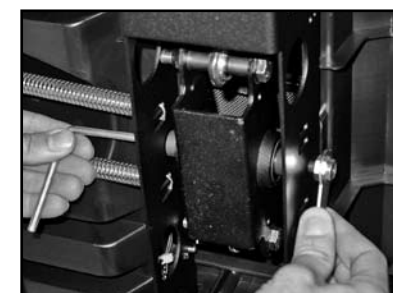

Figure 3-3

Assembly Guide

Step 4: INSTALLING DRIVE BELT

Locate the following for this step:

PARTS:

- TreadClimber® Base & Treadle Assembly from Step 3.
- One (1) Drive Belt

TOOLS:

- 3/16" Hex Key (included)

4-1 Place drive belt over roller pulley and motor pulley (see Figure 4-1).

4-2 Make sure belt is seated into grooves and installed exactly as shown (see Figure 4-2).

4-3 Using (1) 3/16" hex key completely remove motor shipping bolt from motor pan (see Figure 4-3) and retain the bolt after removing.



NOTE: Removing shipping bolt will create spring-loaded tension to drive belt and make it tight.

4-4 Carefully lay unit back over to the upright position.

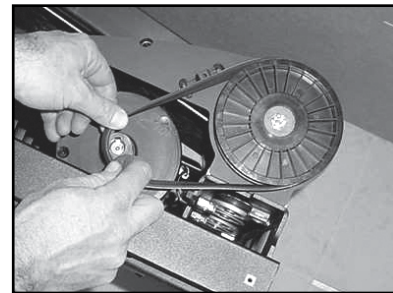

Figure 4-1

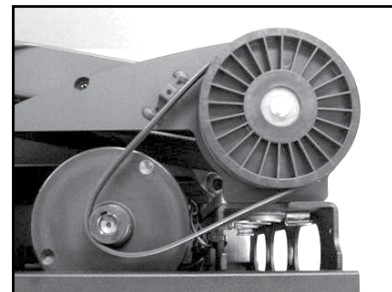

Figure 4-2

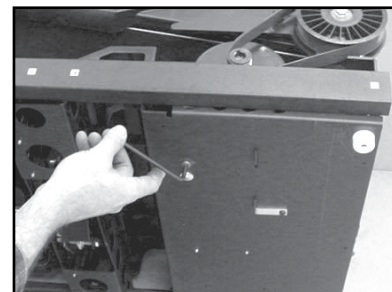

Figure 4-3

Step 5: LOCKING THE TREADLES

Locate the following for this step:

PARTS:

- TreadClimber® Base & Treadle Assembly from Step 4.

5-1 Line up the treadles until they are parallel with each other.

5-2 Move the locking lever downward and to the left and then upward into the 'locked' position with your foot (see Figure 5-1). You may need to gently rock the treadles up and down with your hand until you hear a 'click' to lock the treadles.



NOTE: Locking lever must be all the way to the top of the front plate. If not fully engaged the treadles may unlock during workout.

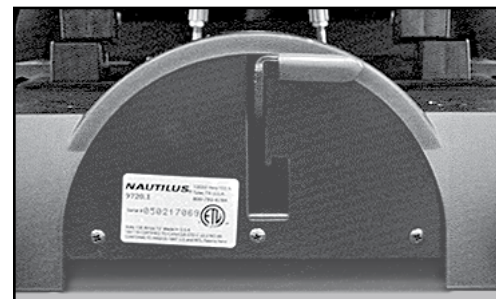

Figure 5-1
Lever in locked position

Assembly Guide

Step 6: INSTALLING THE UPRIGHTS

Locate the following for this step:

PARTS:

- TreadClimber® Base & Treadle Assembly from Step 5.
- One (1) Left Upright Support & Hydraulic Cylinder
- One (1) Right Upright Support & Hydraulic Cylinder

HARDWARE:

- Two (2) 5/16" x 1" Button Head Screws

6-1 On the base assembly screw a 5/16" x 1" button head screw half way in on the outside of both the right and left lower upright bracket (see Figure 6-1).

6-2 Place the left upright onto the left upright bracket (see Figure 6-2), so it rests on the button head screw (see Figure 6-3). Make sure the cylinder bracket is at the top and pointing to rear.

6-3 Repeat this process on the right side.

Figure 6-1



Figure 6-2



Figure 6-3

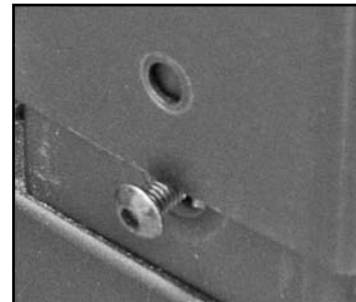

Step 7: INSTALLING THE UPRIGHT JUNCTION COVERS AND COSMETIC PLUGS

Locate the following for this step:

PARTS:

- TreadClimber® Base & Treadle Assembly from Step 6.
- Two (2) Plastic Upright Junction Covers

HARDWARE:

- Four (4) Cosmetic Plugs

7-1 Place the plastic upright junction covers onto the top of left upright support (see Figure 7-1).

7-2 Insert the cosmetic plugs (2 per side) into the holes on the top, inside and outside of the left upright support (see Figure 7-2).

7-3 Repeat this process on the right side.

Figure 7-1

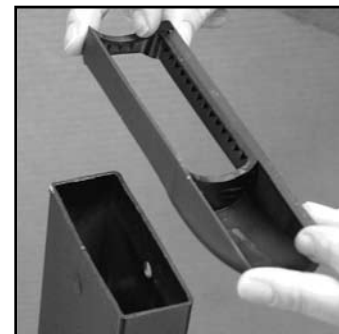

Figure 7-2



Assembly Guide

Step 8: INSTALLING THE CONSOLE/ HANDLEBAR ASSEMBLY

Locate the following for this step:

PARTS:

- TreadClimber® Base & Treadle Assembly from Step 7.
- Console/Handlebar Assembly

HARDWARE:

- Six (6) 5/16" x 1" Button Head Screws
- Six (6) 5/16" Flat Washers SAE

TOOLS:

- 3/16" Hex Key (included)

8-1 With the help of another person, carefully lift the console/handlebar assembly above the tops of the upright supports. Feed the cable down the top of the right upright support (see Figure 8-1 & 8-1A). Make sure cable extends through the bottom of the right upright.

8-2 Slide the brackets on the console/handlebar assembly into the tops of the upright supports—both sides at the same time. Be careful when sliding the console/handlebar assembly onto the uprights to avoid damaging the electrical cable.

8-3 Attach the upright using (6) 5/16" x 1" button head screws and (6) 5/16" flat washers SAE (3 per upright). Tighten with the provided 3/16" hex key (see Figure 8-2).

8-4 Pull out the wire connector at the bottom of the right upright support. Firmly connect the electrical cable at the bottom of the right upright support to the cable on the right side of the base upright bracket (see Figure 8-3).



Figure 8-1



Figure 8-1A

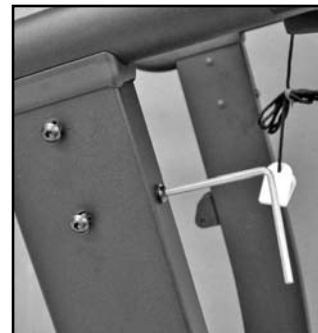

Figure 8-2

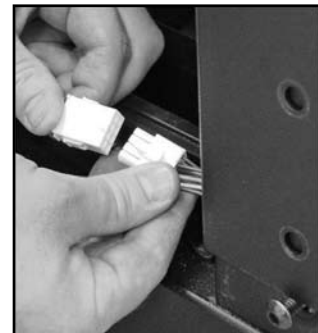

Figure 8-3

Assembly Guide

Step 9: SECURING THE CONSOLE/ HANDLEBAR ASSEMBLY

Locate the following for this step:

PARTS:

- TreadClimber® Base & Treadle Assembly from Step 8.

HARDWARE:

- Six (6) 5/16" x 1" Button Head Screws
NOTE: Two (2) of the 5/16" x 1" Button Head screws are already inserted into the bottom of the right and left upright supports.
- Six (6) 5/16" flat washer SAE

TOOLS:

- 3/16" Hex Key (included)

9-1 With the help of another person, carefully lift the upright and remove the 5/16" x 1" button head screw at the base of the support on the right side. Carefully lower the upright on to the upright bracket base, without damaging the electrical cable. Repeat on the left side.

9-2 Attach the upright using (6) 5/16" x 1" button head screws and (6) 5/16" flat washers SAE (3 per upright). Tighten with the provided 3/16" hex key (see Figure 9-1). Repeat this process on the remaining bracket.

Figure 9-1



NOTE: Tighten the front (2) screws first (1 per upright) and then the (4) side screws (two per outward side of upright). Tightening in this order will result in a tighter fit.

Assembly Guide

Step 10: ATTACHING THE HYDRAULIC CYLINDERS

Locate the following for this step:

PARTS:

- TreadClimber® Base & Treadle Assembly from Step 9.

HARDWARE:

- Two (2) 5/16" x 1-1/2" Button Head Screws
- Two (2) 5/16" Acorn Nuts
- Two (2) 5/16" x 1" Button Head Screws
- Two (2) 5/16" Flat Washers

TOOLS:

- 3/16" Hex Key (included)
- 9/16" Open End Wrench (included)

10-1 First bolt the dial end of the cylinders to the uprights using (1) 5/16" x 1-1/2" button head screw and (1) 5/16" acorn nut, per side. Tighten with the provided 9/16" open end wrench and 3/16" hex key (see Figure 10-1).

10-2 Make sure that the white arrows located on the Workout Level Setting Dials at the top of the Hydraulic Cylinders face the rear of the machine where you can easily see them during your workout.

10-3 Starting on the right side, pull the cylinder down and place the eyelet on the Cylinder Stud protruding from the treadles. Attach the hydraulic cylinder using (1) 5/16" x 1" button head screws and (1) 5/16" flat washers (see Figure 10-2).

10-4 Repeat this process on the left side.



Figure 10-1

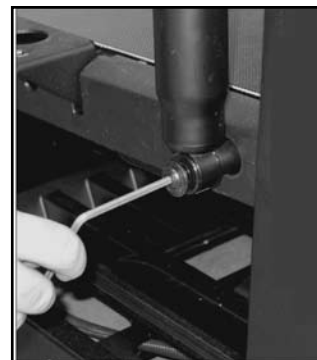

Figure 10-2



NOTE: If having difficulty placing hydraulic cylinder(s) on treadle stud, loosen lower upright screws, place cylinder on the stud and retighten the upright screws.

Step 11: INSPECTING ASSEMBLY

11-1 Remove the protective plastic film from the console face. Inspect all attachments you have made thus far and tighten all bolts securely before proceeding to Step 12.

Assembly Guide

Step 12: MOUNTING THE FRAME COVERS

Locate the following for this step:

PARTS:

- TreadClimber® Base & Treadle Assembly from Step 11.
- Left Plastic Frame Cover
- Right Plastic Frame Cover

HARDWARE:

- Six (6) #10 Phillips Head screws

TOOLS:

- #2 Phillips Head Screwdriver (included)

12-1 Using the provided #2 Phillips screwdriver, mount the left and right Plastic Frame Covers to the sides of the base frame using (6) #10 Phillips head screws (3 per side—see Figures 12-1 & 12-2).

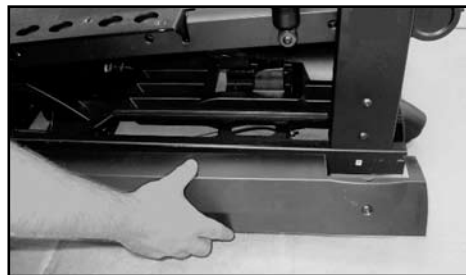

Figure 12-1

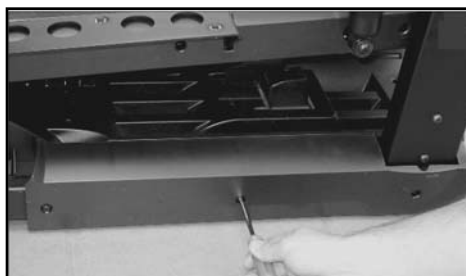

Figure 12-2

Step 13: MOUNTING THE REAR COVER

Locate the following for this step:

PARTS:

- TreadClimber® Base & Treadle Assembly from Step 12.
- Rear Cover

HARDWARE:

- Four (4) #10 Phillips Head Screws

TOOLS:

- #2 Phillips Head Screwdriver (included)

13-1 Using the provided #2 Phillips screwdriver, mount the rear cover to the back of frame (see Figure 13-1) using (4) #10 Phillips head screws (2 per side—see Figure 13-2).



Figure 13-1



Figure 13-2

Assembly Guide

Step 14: MOUNTING THE DRIVE COVERS

Locate the following for this step:

PARTS:

- TreadClimber® Base & Treadle Assembly from Step 13.
- Left side Plastic Drive Cover
- Right side Plastic Drive Cover

HARDWARE:

- Six (6) #10 Phillips Head Screws

TOOLS:

- #2 Phillips Head Screwdriver (included)

14-1 Using the #2 Phillips screwdriver, mount the left and right plastic drive covers to the sides of the base using (6) #10 Phillips head screws (3 per side—see Figure 14-1).

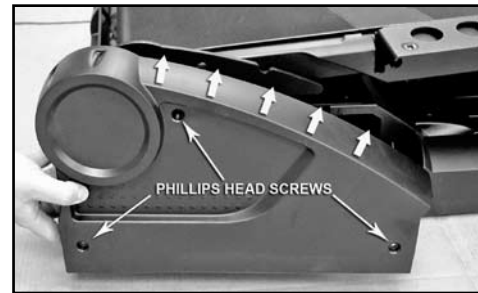

Figure 14-1

Step 15: ATTACHING THE SIDE FOOT SUPPORT PLATFORMS

Locate the following for this step:

PARTS:

- TreadClimber® Base & Treadle Assembly from Step 14.
- Left side Foot Support Platform
- Right side Foot Support Platform

HARDWARE:

- Six (6) 1/4" X 1" Flat Head Screws

TOOLS:

- 5/16" Hex Key (included)

15-1 Using the 5/16" hex key mount the side foot support platforms to each treadle with three (3) 1/4" x 1" flat head screws (3 per side—see Figure 15-1 & 15-2).



Figure 15-1

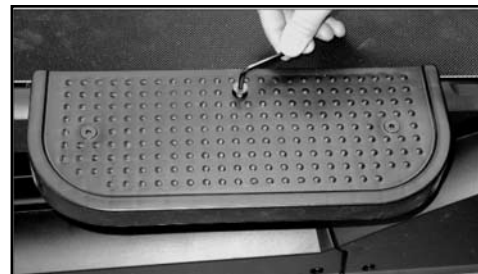

Figure 15-2



NOTE: Make sure that the walking belts on either side do not get trapped under the Side Foot Support Platforms when you mount them. You may need to adjust the position of the platforms if the belts rub against the Side Foot Support Platforms.

Assembly Guide

Step 16: AFFIX TreadClimber® DECALS

Locate the following for this step:

PARTS:

- TreadClimber® Base & Treadle Assembly from Step 15.

HARDWARE:

- Two (2) Treadle Decals
- Two (2) Drive Cover Decals

16-1 There are four places on the Bowflex® TreadClimber® exercise machine where you will need to affix the enclosed TreadClimber® Decals (see Figure 16-1 and Illustration 16-A). Clean the application surface with a wet cloth and dry thoroughly before affixing decal. Position the decal above the application surface to center it before removing from the sticky backing and pressing onto the base surface.

16-2 Gently wipe the affixed decal with your hand or a cloth to remove air bubbles.

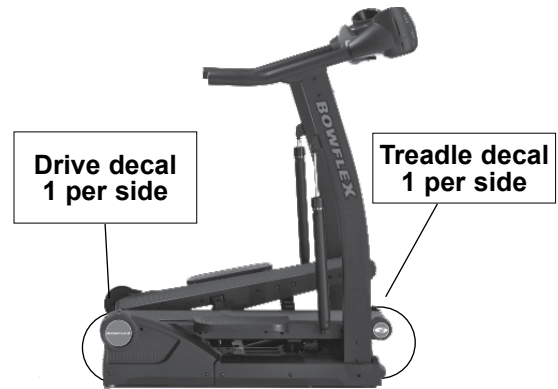

Figure 16-1

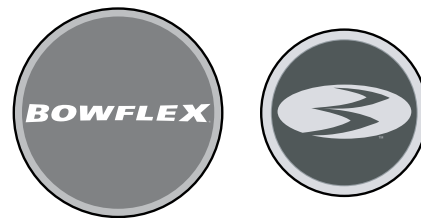

Illustration 16-A:
TreadClimber® Drive and
Treadle Decals

Step 17: INSPECTING ASSEMBLY

17-1 Now that you have assembled your Bowflex® TreadClimber® exercise machine, it is VERY IMPORTANT to tighten all screws and bolts and visually inspect the TreadClimber® machine. Make sure that your TreadClimber® machine has been assembled correctly and securely, and that there are no loose, uncovered or unattached parts prior to use.



Failure to visually check and test assembly before use can cause damage to the TreadClimber® machine and serious injury to users and bystanders and can also compromise the effectiveness of your exercise program.

Step 18 – ATTACHING THE POWER CORD

18-1 Make sure that the Main Power Switch is in the 'Off' position, then carefully insert the power cord into the Incoming Power Plug at the rear of the base unit (Figure 18-1). Always plug into the base before plugging into the wall outlet.



Figure 18-1

NOTE: Your TreadClimber® machine plugs into any standard grounded (three-prong) wall outlet and feeds into an incoming power plug on the back of the base. NEVER remove the grounding prong from the power plug and never use a two-prong adapter without grounding wire!

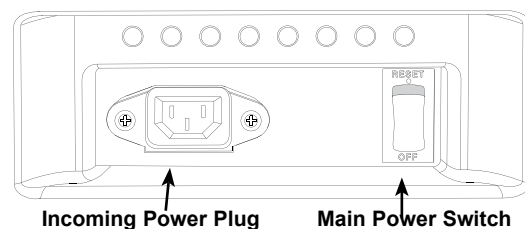

Assembly Guide

Step 19: CALIBRATION PROCESS (TC3000 and TC5000 only)



WARNING

Failure to calibrate your machine prior to use could result in machine failure and could cause injury.

During the entire calibration process, stand on the side foot support platforms or rubber mat only, do not stand on the walking belts!

DO NOT STEP ON THE BELTS DURING THIS ENTIRE PROCESS.

Owners of the TC3000 or TC5000 will need to calibrate the TreadClimber® machine before they can begin exercising. Owners of the TC1000 do not need to complete this step.

Calibrating the TC3000 and TC5000 is an important part of troubleshooting maintenance.

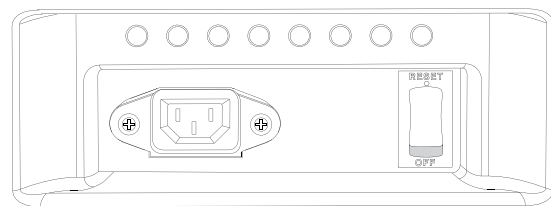

Figure 19-1
Main Power Switch "On"

NOTE: You will also need to re-calibrate your machine in the event of a power outage or if you have replaced a TreadClimber® component, such as a belt, or motor.

19-1 Plug power cord into wall outlet.

19-2 Turn on Main Power Switch (see Figure 19-1).

19-3 Stand on the side foot support platforms or rubber floor mat, **DO NOT STAND ON THE BELTS.**

19-4 Insert the Safety Key, press and hold down the POWER button, then very quickly press and hold down the SLOWER button. Continue to hold down the POWER and SLOWER buttons (see Figure 19-2 for the TC5000 and Figure 19-3 for the TC3000).

NOTE: If the Safety Key is not fully inserted into the safety keyhole, the TreadClimber® machine will **NOT** power up.

19-5 At this point you should see the numbers start to decrease on the console.

19-6 While continuing to hold down the POWER and SLOWER buttons, remove and re-insert the Safety Key.

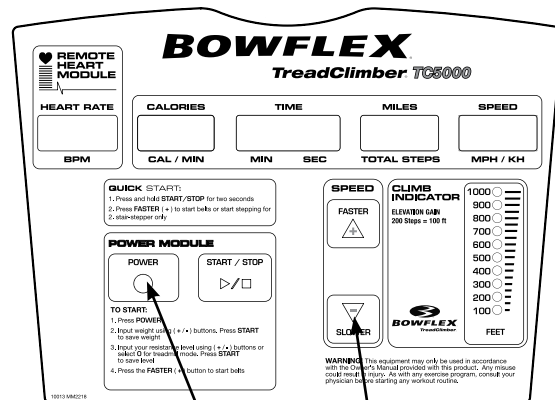

Figure 19-2
TC5000 Power & Slower Buttons

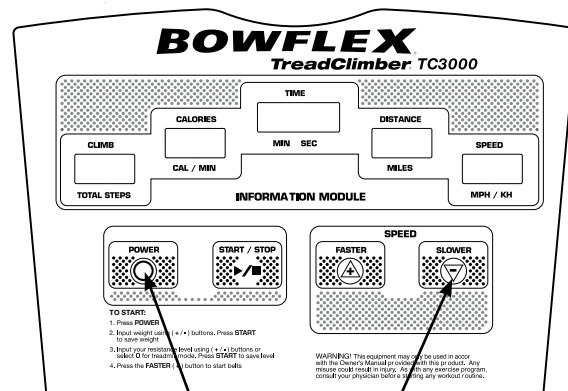

Figure 19-3
TC3000 Power & Slower Buttons

Assembly Guide

19-7 Release the POWER and SLOWER buttons.

The TIME display will read “CAL”, “PrSS”, “Strt”.

19-8 Press the START/STOP button. This will start the calibration procedure.

19-9 During the calibration procedure, the belts will start and stop and the displays will show various numbers that relate to calibration—DO NOT INTERRUPT CALIBRATION.

19-10 When calibration has completed “CAL” “PASS” will show in the TIME display.

19-11 Remove and re-insert the Safety Key to clear the displays.

When the Bowflex® TreadClimber® exercise machine has completed calibration, you may begin your workout.



NOTE: During calibration 100 FT LED on TC5000 signifies belt speed sensor, 1000 FT LED is step sensor. During calibration, some models of the TC3000 will show the step sensor in the DISTANCE window as a heart and the speed sensor in the SPEED window as a heart.

Explanation of Calibration Display Messages (for information only):

During calibration, the TIME display will show you text messages updating you as to the status of calibration. When there is no text message in the TIME display window, the other displays will show the following:

HEART RATE (TC5000 Only) – will show the status of the motor control relay.

- “ON” signifies the power relay is on and energizing the motor.
- “OFF” signifies the motor control relay is off and not energizing the motor.

CALORIES/CAL PER MIN – will show the version number of the software.

TIME – will show either a text message regarding auto-calibration (“dOnE”, “Strt”, etc.) or the actual Pulse Width Modulation (PWM) number (a number that provides digital information about base unit functions to the console) if START/STOP, FASTER or SLOWER is pressed during calibration.

MILES/TOTAL STEPS (DISTANCE/MILES for TC3000) – will show the calibration of the total step count.

SPEED – will display the actual belt speed during the calibration function.

Bowflex® TreadClimber® 100% Satisfaction Guarantee

We want you to know that your TreadClimber® machine is a superior product. Your satisfaction is guaranteed. If, for any reason, you are not 100% satisfied with your TreadClimber® machine, please follow the instructions below to return your merchandise and receive a refund of the purchase price, less shipping and handling.

1. Call a TreadClimber® Representative at 1-800-NAUTILUS (1-800-628-8458) for a Return Authorization Number. Return Authorization will be granted if:
 - a. You purchased your Bowflex® TreadClimber® exercise machine directly from Nautilus, Inc.; and
 - b. You are calling within 30 days of the delivery date of your merchandise.

At the time of your Return Authorization Call, the TreadClimber® Representative will also give you the address where you will send your return.

2. All returned merchandise must be properly packaged in the original boxes and in good condition.



NOTE: You are responsible for return shipping and for any damage or loss to merchandise that occurs during return shipment. We highly recommend that you insure your shipment.

3. Please mark all boxes clearly with:

- Return Authorization Number
- Your Name
- Your Address
- Your Phone Number

Boxes without this information clearly marked on the outside may be refused.

4. Please make copies of your original invoice and put one in each box of merchandise. Nautilus, Inc. must receive your shipment within two weeks from the date the TreadClimber® Representative issued you your Return Authorization Number.

Refunds may be denied or delayed if these instructions are not completely followed.

This TreadClimber® Satisfaction Guarantee applies only to merchandise purchased by consumers directly from Nautilus, Inc. This guarantee does not apply to sales made by dealers or distributors.

Warranty

What Does This Warranty Cover?

Nautilus, Inc. warrants to the original purchaser of the Bowflex® TreadClimber® home fitness machine that the TreadClimber® machine is free from defects in materials and workmanship, when used for the purpose intended, under normal conditions, provided it receives proper care and maintenance as set forth herein. This warranty is extended only to the original purchaser and is not transferable or applicable to any other person.

This warranty is good only for TreadClimber® products sold and used in the United States or Canada and does not extend to any territories or countries outside the United States and Canada. Unauthorized tampering with or opening the unit will void the warranty. Do not attempt to make any repair yourself to the motor.

Additionally, this warranty will not cover any commercial use of the TreadClimber® machine. This includes gyms, corporations, clubs and any public or privately incorporated agency that has a TreadClimber® machine for use by its members, employees or affiliates.

How Long Does Warranty Coverage Last?

TC1000

Residential

- 1 Year on Motor
- 1 Year on Electronics
- 1 Year on all Other Parts
- 1 Year on Hydraulic Resistance Cylinders

Commercial

This warranty is void if TreadClimber® machine is used in a Commercial Environment.

TC3000

Residential

- 3 Years on Motor
- 2 Years on Electronics
- 2 Years on all Other Parts
- 1 Year on Hydraulic Resistance Cylinders

Commercial

This warranty is void if TreadClimber® machine is used in a Commercial Environment.

TC5000

Residential

- 5 Years on Motor
- 3 Years on Electronics
- 3 Years on all Other Parts
- 2 Years on Hydraulic Resistance Cylinders

Commercial

This warranty is void if TreadClimber® machine is used in a Commercial Environment.

These warranties cover all defects in material or workmanship of the TC1000, TC3000 or TC5000. Warranties do not cover commercial use or misuse and abuse by the consumer.

To make this warranty effective, you must completely fill out the TreadClimber® Warranty Registration Card within 30 days of the purchase of your TreadClimber® machine, and return it to the address on the Warranty Registration Card.

Warranty

Warranty Does Not Cover

- A Bowflex® TreadClimber® exercise machine purchased for commercial or institutional use.
- Damage due to use by persons who weigh more than 300 pounds (136 Kilograms).
- Damage due to abuse, accident, failure to follow instructions or warnings in the Owner's Manual, misuse, mishandling, accident or Acts of God (such as floods, tornadoes, hurricanes, power surges, etc.).
- Damage due to normal wear and tear.

Exclusions

THIS WARRANTY AND THE REMEDIES SET FORTH HEREIN ARE EXCLUSIVE AND IN LIEU OF ALL OTHER WARRANTIES, ORAL OR WRITTEN, EXPRESS OR IMPLIED. NAUTILUS, INC. SPECIFICALLY DISCLAIMS AND EXCLUDES ANY AND ALL OTHER WARRANTIES, WHETHER EXPRESS, IMPLIED OR STATUTORY, INCLUDING, WITHOUT LIMITATION, WARRANTIES OF MERCHANTABILITY AND FITNESS FOR A PARTICULAR PURPOSE, AND ANY IMPLIED WARRANTIES ARISING FROM THE COURSE OF DEALING OR USAGE OF TRADE. NO NAUTILUS, INC. AGENT OR EMPLOYEE IS AUTHORIZED TO MAKE ANY MODIFICATION, EXTENSION OR ADDITION TO THIS WARRANTY.

What Nautilus, Inc. Will Do

During your Warranty Coverage Period, Nautilus, Inc. will repair any TreadClimber® machine that proves to be defective in materials or workmanship. In the event repair is not possible, Nautilus, Inc. will either replace your TreadClimber® machine or refund your purchase price, less shipping and handling.

Nautilus, Inc. reserves the right to substitute material of equal or better quality if identical materials are not available at the time of service under this Warranty. The replacement of the product under the terms of the Warranty in no way extends the Warranty period.

Limitation of Remedies

THE PURCHASER'S EXCLUSIVE REMEDY IS LIMITED TO REPAIR OR REPLACEMENT OF ANY COMPONENT DEEMED BY NAUTILUS, INC. TO BE DEFECTIVE UNDER THE TERMS AND CONDITIONS STATED HEREIN. EXCEPT AS PROHIBITED BY LAW. IN NO EVENT WILL NAUTILUS, INC. BE LIABLE FOR ANY SPECIAL, CONSEQUENTIAL, INCIDENTAL, INDIRECT OR ECONOMIC DAMAGES, REGARDLESS OF THE THEORY OF LIABILITY (INCLUDING, WITHOUT LIMITATION, PRODUCT LIABILITY, NEGLIGENCE OR OTHER TORT) OR FOR ANY LOST REVENUE, PROFIT, DATA, PRIVACY OR FOR ANY PUNITIVE DAMAGES ARISING OUT OF OR RELATED TO THE USE OF THE TREADCLIMBER® EVEN IF NAUTILUS, INC. HAS BEEN ADVISED OF THE POSSIBILITY OF SUCH DAMAGES. THIS EXCLUSION AND LIMITATION SHALL APPLY EVEN IF ANY REMEDY FAILS OF ITS ESSENTIAL PURPOSE. SOME STATES DO NOT ALLOW THE EXCLUSION OR LIMITATION OF CONSEQUENTIAL OR INCIDENTAL TYPE DAMAGES SO THE ABOVE LIMITATION MAY NOT APPLY TO YOU.

How to Get Service

Return the defective part *at your expense* to the address given you by a Bowflex® TreadClimber® Representative at 1-800-NAUTILUS (1-800-628-8458).

Always include an explanation of the problem with service shipments.

For information, contact a TreadClimber® Representative at 1-800-NAUTILUS (1-800-628-8458). Adequate protective packaging of the defective parts or unit and cost of shipping to the above address are your responsibility.

The required part or unit will be returned to you *at the company's expense*.

How State Law Applies

This warranty gives you specific legal rights, and you may also have other rights, which vary from state to state.

After Your Warranty Expires

Once your warranty has expired, Nautilus, Inc. will still assist you with replacements or repairs to parts and labor, but you will be charged for these services. Call a TreadClimber® Representative at 1-800-NAUTILUS (1-800-628-8458) for information on post-warranty parts and services.

Bowflex® TreadClimber® Warranty Registration Card

IMPORTANT! MAIL WITHIN 30 DAYS OF PURCHASE

PLEASE PRINT CLEARLY – THANK YOU

1. Mr. 2. Mrs. 3. Ms. 4. Miss

Customer ID from Invoice

Name:

Address: Apt. #:

City: State: Zip:

Phone number: -

E-Mail address:

Is this your primary address? Yes No

Place of purchase:

Date of purchase:

Purchaser date of birth:

Gender: Male Female

Marital status: Married Single

Including yourself, total number of people living in your household: (Examples: 01, 02, 03 ...)

Would you like to receive additional information on healthy lifestyle products? Yes No

Which best describes your family income:

- Under \$15,000 \$25,000 – \$34,999 \$50,000 – \$74,999 \$100,000 – \$149,999
 \$15,000 – \$24,999 \$35,000 – \$49,999 \$75,000 – \$99,999 Over \$150,000

What other types of exercise equipment do you own?

Did you receive this item as a gift? Yes No

Name of original purchaser:

Original purchaser customer ID number:

Thanks for filling out this questionnaire. Your answers are important to us. Please check here if you would prefer not to obtain information on new and interesting opportunities from other exciting companies.

What Is Covered

Nautilus, Inc. warrants to the original purchaser of the TreadClimber® home fitness machine that the TreadClimber® machine is free from defects in materials or workmanship, with the exceptions stated below. This warranty is not transferable or applicable to any person other than the original purchaser and is only applicable for products sold and used in the United States or Canada. Unauthorized tampering with or opening the unit will void the warranty.

TreadClimber® TC5000

- 5 years on Motor
- 3 years on Electronics
- 3 years on all Other Parts
- 2 years on Hydraulic Resistance Cylinders

TreadClimber® TC3000

- 3 years on Motor
- 2 years on Electronics
- 2 years on all Other Parts
- 1 year on Hydraulic Resistance Cylinders

TreadClimber® TC1000

- 1 year on Motor
- 1 year on Electronics
- 1 year on all Other Parts
- 1 year on Hydraulic Resistance Cylinders

Warranties Do Not Cover

- A TreadClimber® machine purchased for commercial or institutional use.
- Damage due to use by persons who weigh more than 300 pounds.
- Damage due to abuse, accident, failure to follow instructions or warnings in the Owner's Manual, misuse, mishandling, accident or Acts of God (such as floods or power surges).
- Damage due to normal wear and tear.

What We Will Do

During your Warranty Coverage Period, Nautilus, Inc. will repair any TreadClimber® machine that proves to be defective in

materials or workmanship. In the event repair is not possible, Nautilus, Inc. will either replace your TreadClimber® machine or refund your purchase price, less shipping and handling

How To Get Service

Return the defective part, at your expense, to the address given to you by a TreadClimber® Representative at 1-800-NAUTILUS (1-800-628-8458). Include an explanation of the problem. Adequate protective packaging of the defective parts or unit and cost of shipping are your responsibility. The repaired part or unit will be returned to you at the company's expense.

How State Law Applies

This warranty gives you specific legal rights, and you may also have other rights which vary from state to state.

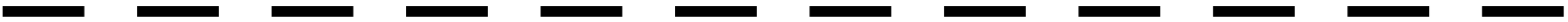

Please fold over and tape before mailing

Please fold over and tape before mailing

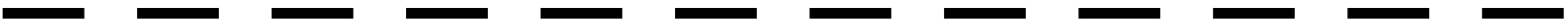

Place
Stamp
Here

BOWFLEX® TREADCLIMBER®
16400 S.E. Nautilus Drive
Vancouver, WA 98683

Getting Started

Before You Start

1. Make sure you have calibrated your machine (TC3000 or TC5000 only) as outlined in Step 19 of the Assembly Guide before using your Bowflex® TreadClimber® exercise machine for the first time.
2. Determine your workout mode (treadmill, stair-stepper or TreadClimber® mode).

NOTE: If you are working out in treadmill mode, you must lock the treadles by following the locking procedure in the Locking the Treadles section in this manual.

3. Adjust the Workout Level Settings on the Hydraulic Cylinders following the procedure in the Adjusting Workout Level Settings section on Page 33.

Do not stand on the machine while adjusting hydraulic resistance settings.

4. If you are using the Heart Rate Monitor (TC5000 only), thoroughly follow the heart rate transmitter chest-strap directions in the Remote Heart Module section in this manual.
5. Plug the power cord into the base of the machine and into a grounded AC wall outlet. Always plug into the machine before plugging into the wall outlet.

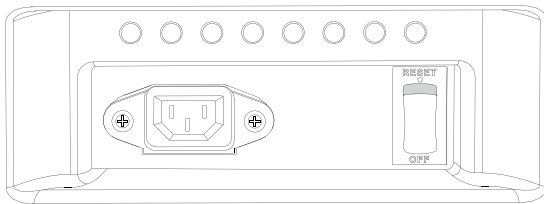

Main Power Switch “Off”

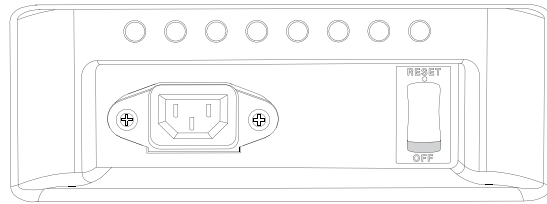

Main Power Switch “On”

NOTE: The TreadClimber® machine may be equipped with an external circuit breaker.

6. Main Power Switch.

- Power is switched on using the Main Power Switch near the incoming power cord plug.
- Power is supplied to the motor and console only when the unit is plugged in and the Main Power Switch is turned on.

NOTE (TC3000 and TC5000): The console will not light up until you turn on the console by pressing the POWER Button (START/STOP Button for the TC1000).

- Position the power cord along the side of the TreadClimber® machine, making sure that it is out of your way when you dismount the machine. Always take care when securing the power plug to prevent stepping on it and always check the placement of the cord and plug before beginning your workout.

7. Straddle the belts and stand on the Side Foot Support Platforms. Insert the Safety Key into the Safety Keyhole and clip the Safety Key cord to your clothing.

- The console will NOT power up if the Safety Key is not properly inserted into the Safety Keyhole.
- In the event of an emergency, you may need to pull the Safety Key out while the TreadClimber® machine is in motion. Be aware that this will cut all power to the console and the belts will stop quickly (brace yourself—this is an abrupt stop).
- You should always wear the Safety Key clip attached to your clothing during workouts to be prepared to stop the belts quickly, if ever necessary.



**Safety Key and Cord
(TC5000 & TC3000)**

Getting Started

8. Begin your workout using the appropriate instructions for your selected workout mode.

NOTE: Resistance and weight settings are what your Bowflex® TreadClimber® exercise machine uses to calculate your calories burned (TC3000 and TC5000). If your Workout Level or weight changes, you must remember to change your settings on the console to insure accurate calorie burn calculation.

Select Your Workout Level

CONSULT YOUR PHYSICIAN BEFORE STARTING ANY EXERCISE PROGRAM. Only he or she can determine the exercise program that is appropriate for your particular age and condition. If you have not been exercising or are pregnant or have a heart condition or any physical limitation, failure to consult your physician before engaging in physical exercise, such as using the Bowflex® TreadClimber® exercise machine, could result in serious injury or death. If while using the Bowflex® TreadClimber® exercise machine you have any pain or tightness in your chest, an irregular heart beat, shortness of breath, feel faint, light-headed or dizzy or have any pain or discomfort, STOP and consult your physician immediately.

Your TreadClimber® machine uses Hydraulic Resistance Cylinders to absorb your steps and cushion your joints—reducing your overall fatigue and eliminating muscle strain.

Workout Level Settings range from 1 to 12. Workout Level 1 is the easiest workout and Level 12 is the most difficult workout.

Your personal setting will depend on four factors:

- Your weight
- Your fitness level
- The average speed of the belts during your workout
- How deep you want to step

To increase your overall calorie burn, raise your belt speed or raise your Workout Level Setting one or two levels above your suggested level. Raising your Workout Level allows you to take deeper steps, helping your abdominal, gluteus, quadriceps and lower back muscles to work harder, burning more calories, particularly at higher belt speeds.

The following suggested Workout Level Guide is based on average fitness levels and a belt speed of 2 MPH (3.2 KPH) or slower. You should always assess whether that setting is right for you based on your individual needs and fitness level and adjust your Workout Level Settings accordingly.

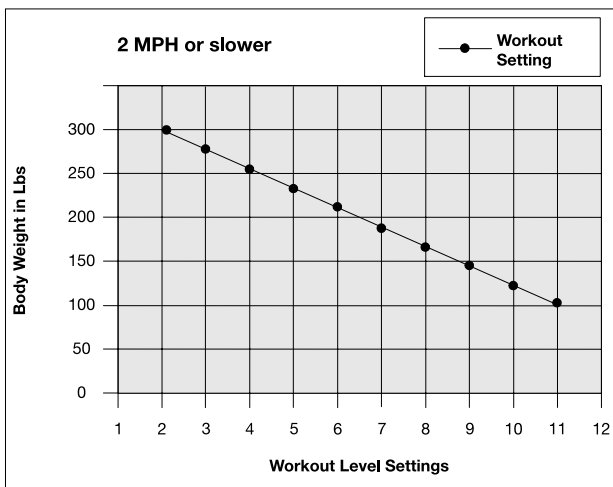

Workout Level Guide



Hydraulic Cylinders

As your endurance levels increase, you may find that your Workout Level has risen, however, you need to always select a low enough setting that you don't "Bottom out".

NOTE: "Bottoming out" happens when the treadle is not adequately supporting your weight (Refer to Workout Level Guide diagram). When this is the case, the treadles may bump against the base if you use too much force on your down-ward step. Use a low enough Workout Level Setting to support your weight for the entirety of your step.

Getting Started



Adjusting Workout Level Settings

If you wish to change your Workout Level Settings during a workout, you must get off the machine before changing the settings. Workout Level Settings are dials located at the top of the Hydraulic Cylinders. Use the dial to line up your desired level with the white arrow.

Remember, setting 1 offers the minimum depth of change of the treadles while setting 12 offers the greatest depth of treadle movement.



Resistance Arrow

NOTE: Although the Workout Level Dial can move continuously in either direction, it is recommended that you only rotate the dial clockwise to setting 12 and counterclockwise to setting 1.

Workout Level Settings may be adjusted incrementally if that best suits your body weight, fitness level and workout preferences (i.e. you may set the Resistance Arrow midway between Levels 2 and 3).

Always verify that the Workout Level Settings are correct for your unique physical needs, and adjust your settings whenever needed to keep the TreadClimber® machine best attuned to your fitness requirements.

Because the Workout Levels are specific to your body weight, you should not need to change them very frequently. Any time you change the Workout Level Dial Settings, you need to also input that Workout Level into the console during setup so that the CALORIE display accurately reflects calories burned (TC3000 or TC5000 only).

NOTE: Actual Workout Level Settings are changed manually, using the Workout Level dials located on each Hydraulic Cylinder, but you will also need to input your Workout Level into the console for calorie burn calculations.

If your actual Workout Level Setting is incremental, input your level as the nearest whole number.

Getting Started

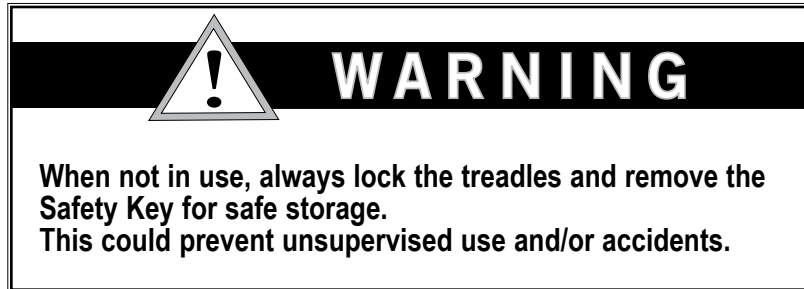

Pausing or Stopping

Pausing or Stopping the TC3000 and TC5000

1. Step off of the belts onto the Side Foot Support Platforms on either side of the treadles.
2. Press START/STOP to stop the belts and console displays, (if you are in stair-stepper mode, pressing START/STOP will stop the console displays).

Belts will slow down to a complete stop. Final workout information will be displayed in the display windows: HEART RATE (TC5000 only), TIME, TOTAL CALORIES BURNED, TOTAL STEPS and TOTAL DISTANCE/MILES.

Windows that display multiple workout information (such as CALORIES/CAL PER MIN) will toggle between their final results every 6 seconds until the workout is resumed or the console is turned off.

3. You may restart your workout by pushing the START/STOP button again.

If you do not push START/STOP again to resume your workout within 5 minutes, your Bowflex® TreadClimber® exercise machine will automatically power off the console. Workout information will be cleared when power to the console is shut off.

4. You may shut off power to the console manually by pushing the POWER button. If this is done during the workout, the console will turn off and the belt will slow to a complete stop. All information from your workout will be cleared.
5. Turn off the Main Power Switch at the base of the machine.
6. Lock the treadles and remove the Safety Key for safe storage when not in use.

NOTE: In case of emergency, you may shut off power by pulling out the Safety Key but this will abruptly stop the belts as well as clearing all workout information from the display windows.

Pausing or Stopping the TC1000

1. Step off the treadles onto the side foot support platforms.
2. Press START/STOP to slow the belts to a stop.
3. If you wish to reset your workout numbers, press the RESET button. RESET only works when the belts are not moving.
4. Make sure to turn off the base power switch and unplug the TreadClimber® machine when you have finished your workout.
5. Lock the treadles and remove the Safety Key for safe storage when not in use.

Getting Started

TC5000 Features

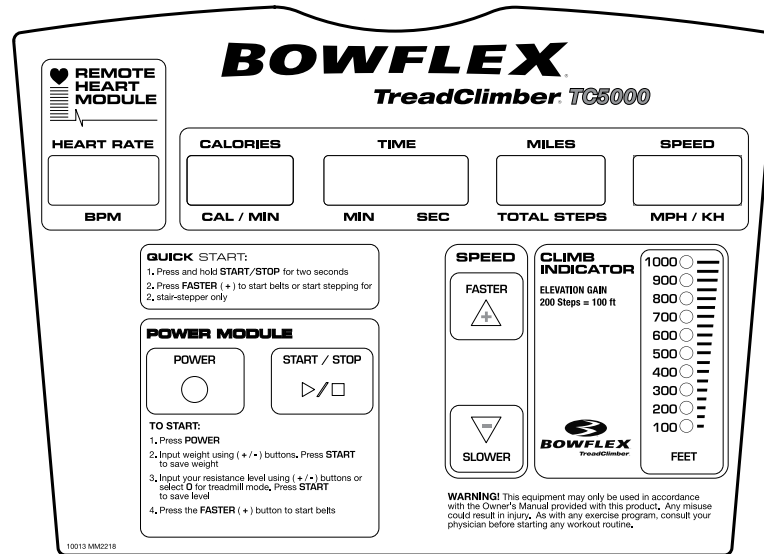

TC5000 Displays

- **HEART RATE/BEATS PER MIN** – Displays your heart rate in beats per minute when you are correctly wearing and using the TreadClimber® heart rate transmitter chest-strap or a TreadClimber® compatible heart rate transmitter chest-strap.
- **CALORIES/CALORIES PER MINUTE** – This screen will toggle between total calories burned (whole number) and calories per minute (includes one decimal place—e.g. 15.5).
- **TIME** – Counts up in minutes and seconds the total time of your workout (e.g. 24:22 minutes).
- **MILES/TOTAL STEPS** – This is the miles (or kilometers) displayed to one decimal point (e.g. 0.8) and Total Steps Taken for the entire length of your workout, displayed as a whole number.
- **SPEED** – Displays your climbing rate in miles (MPH) or kilometers (KPH) per hour to one decimal point (e.g. 3.2 MPH). When unit is used in stair stepper mode, SPEED display will show Steps per Minute.
- **CLIMB INDICATOR** – This display shows the total height of your workout in feet (200 Steps Taken = 100 feet). After 1000 feet, this display starts over again at 100 feet.

Quick Start

QUICK START – The TC5000 has a Quick Start function for your TreadClimber® machine or treadmill workouts that will bypass having to verify your weight and Workout Level Settings. Make sure you lock the treadles following the Locking the Treadles instructions on Page 43 before starting a treadmill workout.

NOTE: Quick Start always reverts to the last workout mode used. If you are not going to use TreadClimber® machine in the same mode as your last usage, you cannot use the Quick Start function.

1. Push and hold the **START/STOP** button for two seconds—this will revert weight and Workout Level to the last numbers saved. (Note: The console will NOT power up if the Safety Key is not properly inserted into the Safety Keyhole.)
2. Press the **FASTER** button to start the belts at 0.7 MPH (1.1 KPH), or start stepping for a stair-stepper workout.
3. Once the belts have started, you may step onto the treadles at any time.
4. Press **FASTER** again to increase belt speed (for treadmill and TreadClimber® modes).

Getting Started

Remote Heart Module (TC5000 Only)

The Remote Heart Module and Heart Rate Transmitter are features on the TC5000 only. You may use the TC5000 Heart Rate Transmitter or any other Heart Rate Transmitter that is compatible with the TreadClimber® TC5000 to help keep yourself within your target fat-burning heart rate zone during your workout.

NOTE: A Heart Rate Strap with a non-replaceable battery is included. It will work with Polar® watches. To promote contact it should be wet with perspiration, gel or saliva. To promote maximum life, it must be rinsed with clean water and dried after each use. A one year life is expected, replacement part T41 is available from Polar® or Nautilus, Inc.

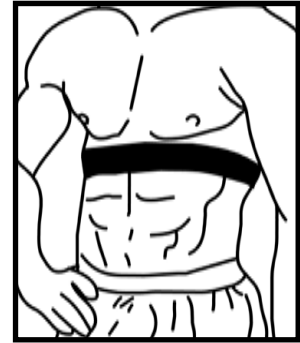

How to Use Your Chest Strap: Using the Bowflex® TreadClimber® heart rate transmitter chest strap, you can monitor your heart rate at any time during your workout:



1. The heart rate transmitter is attached to a chest strap to keep your hands free during your workout.

Attach the transmitter to the elastic chest strap.

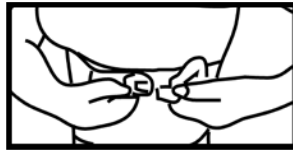

2. Adjust the strap length to fit snugly and comfortably against your skin. Secure the strap around your chest, just below the chest muscles, and buckle it.

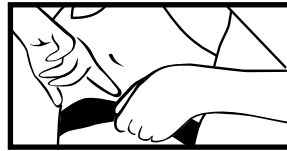

3. Lift the transmitter off your chest and moisten the two grooved electrode areas on the back.



4. Check that the wet electrode areas are firmly against your skin.

5. The transmitter will send your heart rate to the TreadClimber® machine's receiver and your Beats Per Minute (BPM) will be displayed in the HEART RATE display within a matter of several seconds.
6. Always remove the transmitter before cleaning the chest strap. Clean the chest strap regularly with mild soap and water and thoroughly dry it. Residual sweat and moisture keep the transmitter active and drain the battery in the transmitter.

NOTE: Do not use abrasives or chemicals such as steel wool or alcohol for cleaning, as they can damage the electrodes permanently.

Replacement chest straps are available by calling your TreadClimber® Representative at 1-800-NAUTILUS (1-800-628-8458).



ATTENTION

Never immerse the Heart Rate Transmitter in water—doing so could permanently damage the monitor and cause it to malfunction.

If the Heart Rate Transmitter is not sending a signal to your console, check to make certain that the metal electrodes on the chest strap are connecting with your skin. You may need to lightly wet the circles so they adhere.

If no signal appears or you need further information, please call a TreadClimber® Representative at 1-800-NAUTILUS (1-800-628-8458).

Getting Started

Information About Heart Rate Calculations

Your maximum heart rate generally declines with age from about 220 Beats Per Minute (BPM) in childhood to about 160 BPM at age 60. This fall in heart rate is fairly linear, decreasing by approximately one BPM per year. There is no strong evidence to suggest that training influences the decline in maximum heart rate. It should be remembered that individuals of the same age might have quite different maximum heart rates. It is more accurate to calculate this value by undergoing a stress test than by using an age-related formula.

On the other hand, your resting heart rate is greatly influenced by endurance training. The typical adult has a resting heart rate of about 72 BPM whereas highly trained runners may have readings of 40 BPM or lower.

The heart rates below are based on average fitness of persons of the age indicated. You may be more or less fit, and your actual maximum heart rate and zones may be correspondingly higher or lower. You should therefore consult your physician for the maximum heart rate that is right for you and the heart rates that you can safely exercise at.

The best way to burn fat during exercise is to start slowly with a less intense exercise and gradually increase your intensity until your heart rate during exercise is between 60 – 85% of your maximum heart rate, and continue at that pace, keeping your heart rate in that target zone for over 20 minutes.

The longer you maintain your target heart rate, the more fat your body will burn.

The graph below is merely a guideline, showing the generally suggested target heart rate for persons your age. As noted above, your optimal target rate may be higher or lower, depending on your fitness. Consult your physician for your individual target heart rate.

Using the graph below as a guideline, raise and lower the intensity of your workout to keep within the suggested target heart rate for your age.

FAT-BURNING TARGET HEART RATE

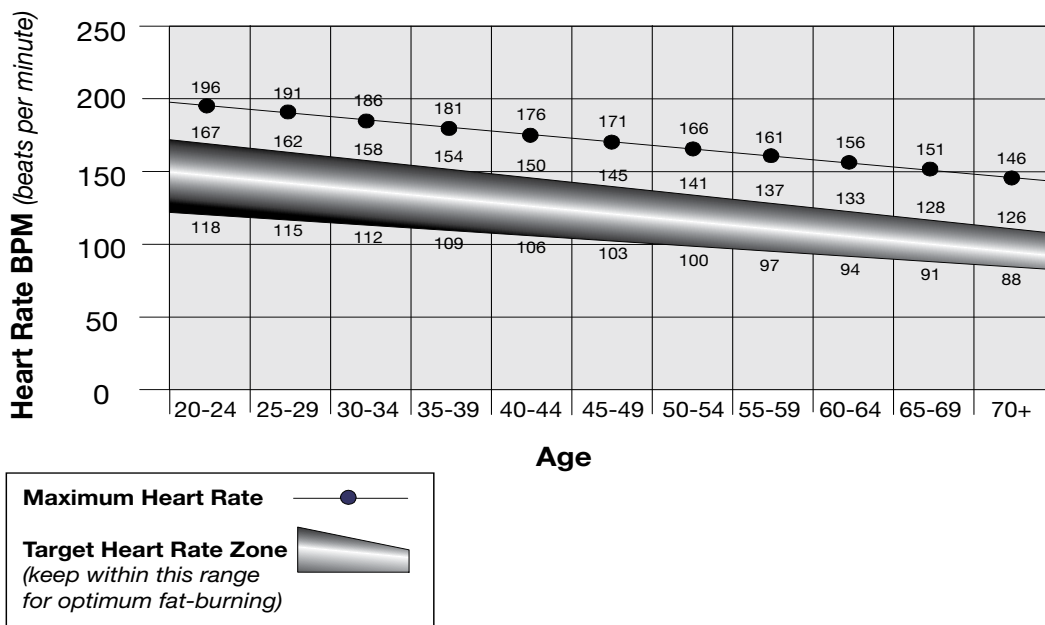

NOTE: As with all exercises and fitness regimens, always use your best judgment when increasing intensity or endurance.

Getting Started

TC3000 Features

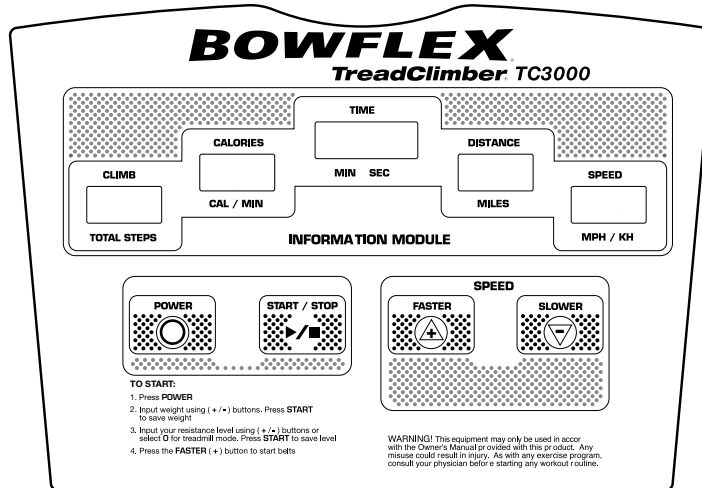

TC3000 Displays

- CLIMB/TOTAL STEPS – This displays the total steps you have taken since starting your workout.
- CALORIES/CALORIES PER MINUTE: This screen toggles between the total calories burned (whole number) and calories per minute (to one decimal place).
- TIME – Counts up the total time of your workout in minutes and seconds (e.g. 24:22 minutes).
- DISTANCE – The total distance you have traveled in miles (to one decimal point, e.g. 3.4 Miles) for this workout.
- SPEED/MPH/KH – Displays your climbing rate in miles or kilometers per hour (e.g. 3.2 MPH).

TC1000 Features

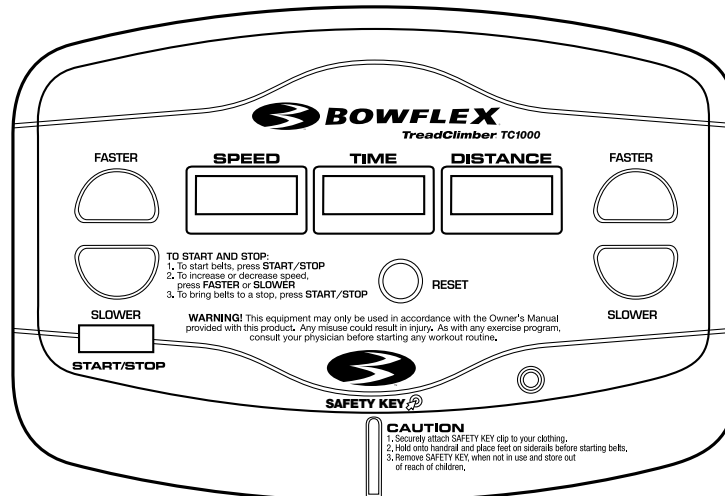

TC1000 Displays

- SPEED – Displays the Speed of your workout in MPH (e.g. 2.4 MPH).
- TIME – Counts up the total time of your workout in minutes and seconds (e.g. 24:22 minutes).
- DISTANCE – The total distance you have traveled in Miles (to one decimal point, e.g. 3.4 Miles) for this workout.
- RESET – This button resets all values in the Displays to zero after you have Paused or Stopped your workout.

Getting Started

Setting English or Metric Measurement Units (TC3000 and TC5000)

You can configure the TC5000 and TC3000 Consoles to display in Miles or Kilometers:

1. Turn the Main Power Switch on the Bowflex® TreadClimber® base to 'On'.
2. Remove the Safety Key.
3. Press and hold the START/STOP button.
4. Insert the Safety Key while holding down the START/STOP button.
5. Console will power up and show "EngL" text in the TIME display.
6. Continue to hold the START/STOP button and the console will toggle between "EngL" and "MET" every three seconds.



English Measurement Display



Metric Measurement Display

7. Release the START/STOP button when desired measurement unit type is displayed.
8. Remove and re-insert the Safety Key to clear the TIME display.

The below is an example of how weight will display in both English Standard and Metric

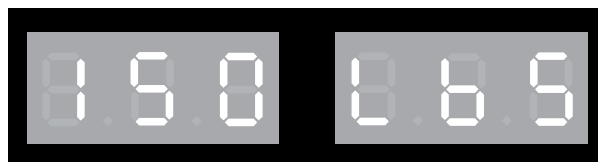

English Measurement—150 Pounds



Metric Measurement—68 Kilograms

Getting Started

Walking Belt Adjustment

If either of the walking belts seem to be tracking excessively to one side or the other, adjustments can be made at the front roller of each treadle.

Misalignment Test and Resolution

Visual Test – Standing beside the unit, set the speed at 2 mph. Standing in front of the unit you will see adjustment bolts on each end of each front roller. If the belt is tracking too far to the right, tighten the right adjustment bolt on that roller using the provided hex key in full turn increments to realign belt. If the belt seems to be tracking too far to the left, do the same thing on the left adjustment bolt for that roller.

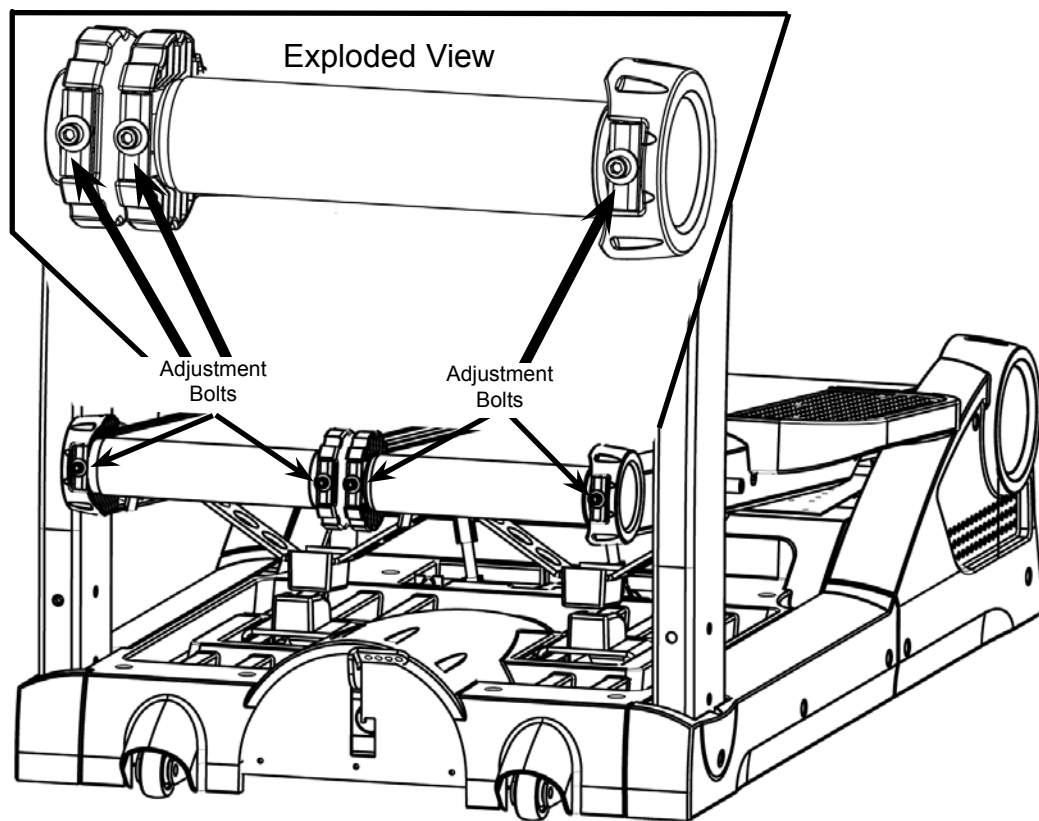

Walking Belt Alignment

NOTE: Belts should not be so tight that you cannot get your hand snugly under them when machine is turned off and unplugged.

Workout Instructions

Determining Your Fitness Level

Endurance is an important way to determine your fitness level. Before you begin exercising on your Bowflex® TreadClimber® exercise machine, you will want to benchmark your current endurance level, based on how well you feel after you take these quick tests on your TreadClimber® machine. To do these tests, you'll need to use your TreadClimber® machine in all exercise modes (TreadClimber®, treadmill and stair-stepper modes).

CONSULT YOUR PHYSICIAN BEFORE TAKING THESE TESTS. Only he or she can determine whether they may not be appropriate for your particular age and condition. If you have not been exercising or are pregnant or have a heart condition or any physical limitation, failure to consult your physician before engaging in physical exercise, such as these three tests, could result in serious injury or death. If while taking the tests, you have any pain or tightness in your chest, an irregular heart beat, shortness of breath, feel faint, light-headed or dizzy or have any pain or discomfort, STOP and consult your physician.

These three quick tests should help you determine at what level you should start training:

Test 1

1. Start a TreadClimber® workout (belts and treadles engaged) at 0.7 MPH (0.5 for TC1000), using the easiest Workout Level Setting for your weight (see the Workout Level Settings table on Page 33), and gradually increase your speed for the next 30 seconds until you reach 2 MPH or until you feel that you are at your personal maximum exertion.
2. Continue for another 15 seconds at that speed, then step off the treadles onto the Side Foot Support Platforms and press START/STOP to stop the belts.
3. Once the belts have stopped, breathe in and out slowly a few times, and then review your level of exertion based on the below scale:

RATE OF PERCEIVED EXERTION SCALE	
1.	Sluggish – heart rate not raised
2.	Comfortable – strolling rather than exercising
3.	Alert and moving – not exerting yourself
4.	Heart rate up – feel activated
5.	Moderate exercise – feel aerobic and warmed up
6.	Invigorated and healthy but could tire out soon
7.	Breathing heavier – pushing yourself
8.	Panting hard – feeling muscle burn
9.	Sharp increase in exertion – almost at maximum effort
10.	Maximum effort – could collapse if pace continued

Based on the above scale:

- Beginner Level perceives exertion at 8, 9 or 10
- Intermediate Level perceives their exertion at 4, 5, 6 or 7
- Advanced Level perceives exertion at 1, 2 or 3

Workout Instructions

Test 2

1. Change over to Treadmill mode (see Locking the Treadles section in this manual) and begin a workout at 0.7 MPH (0.5 for TC1000), gradually increasing your speed for the next 30 seconds, raising speed until you reach 2 MPH or until you feel that you are at your personal maximum exertion.
2. Continue for another 15 seconds at that speed, then step off the treadles onto the Side Foot Support Platforms and press START/STOP to stop the belts.
3. Once the belts have stopped, breathe in and out slowly a few times, and then review your level of exertion based on the Perceived Exertion Scale listed under Test 1 of the Workout Instructions section of this manual.

Test 3

1. Change over to the Stair-Stepper mode using the easiest workout resistance for your weight (see the Workout Level Guide table in the Select Your Workout Level section of this manual), and gradually increase your rate of stepping for the next 30 seconds, taking steps at a moderate depth and height while stepping more quickly until you feel that you are at your personal maximum exertion.
2. Continue for another 15 seconds at that speed and then stop stepping and step off the treadles and onto the Side Foot Support Platforms.
3. Breathe in and out slowly a few times, and then review your level of exertion based on the Perceived Exertion Scale listed under Test 1 of the Workout Instructions section of this manual.

Assessment

After finishing all endurance tests, add the totals of your perceived exertion for Tests 1, 2 and 3 together and divide by three. If your score is:

8 - 10: use the BEGINNER LEVEL workouts on Page 50.

4 - 7: use the INTERMEDIATE LEVEL workouts on Page 50.

1 - 3: use the ADVANCED LEVEL workouts on Page 50.

If at any time you wish to raise your endurance, you should retest your Perceived Exertion Level.

If you follow our workout program, you should see a marked improvement in your endurance after just a few workouts on your Bowflex® TreadClimber® exercise machine.

Workout Instructions

Treadmill Workout

Treadles

Each Bowflex® TreadClimber® treadle is a separate treadmill with its own belt, however both treadles are driven by the same axle and motor. This assures that each belt travels at the same speed. Further, the treadles are interconnected, which provides a balanced relationship between the left and right sides during the workout to give the most cushioned effect to your joints.

Locking the Treadles for Treadmill Workout

You may lock the right and left treadles together to get a treadmill workout at a 10% incline. This incline will increase your overall calorie burn at a slower speed when compared to a standard treadmill.

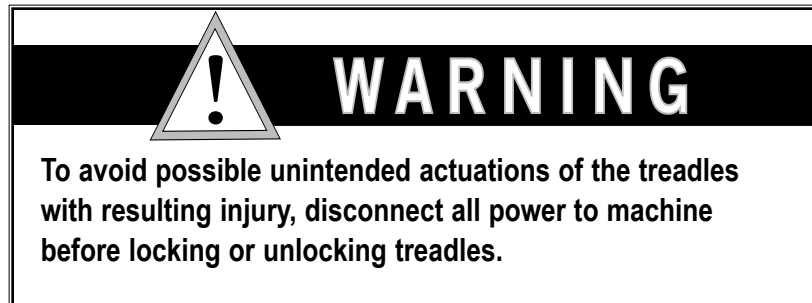

The TreadClimber® machine is equipped with a treadle-locking lever that can be manipulated with your foot.

1. Turn off all power to the TreadClimber® machine and unplug the power cord from the wall outlet.
2. Stand on the ground in front of the TreadClimber® machine and move the treadles together until they line up next to each other.
3. Move the locking lever downward and to the left and then upward into the 'locked' position with your foot. You may need to gently rock the treadles up and down with your hand to lock the treadles - you will hear a 'click'.

NOTE: Locking lever must be all the way to the top of the front plate. If not fully engaged the treadles may unlock during workout.

4. Insert power cord into the wall outlet and turn on the Main Power Switch. Follow the Starting a Treadmill Workout instructions for your model on Page 45 to work out in treadmill mode.



Lever in locked position for treadmill mode



Lever in unlocked position for TreadClimber® mode

5. To release the treadles, turn off the Main Power switch and push the lever downward and to the right with your foot.

NOTE: You will not need to manually change the Workout Level Settings on the Hydraulic Cylinders for a treadmill workout.

Workout Instructions

Starting a Treadmill Workout (TC3000 and TC5000)

1. Make sure you have locked the treadles, following the guidelines in the Locking the Treadles section in this manual.
2. Push POWER to turn on the Console. The console will NOT power up if the Safety Key is not properly inserted into the Safety Keyhole.

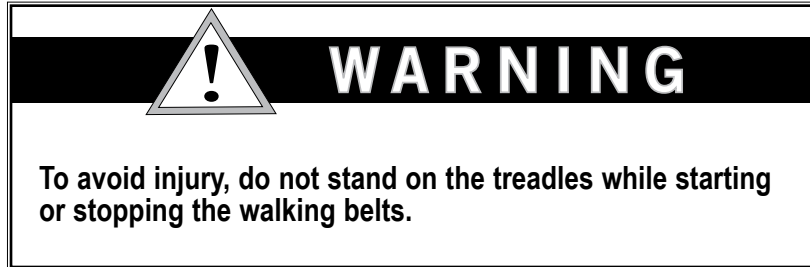

3. Input your weight. For first time use, follow the weight-input instructions for Starting a Bowflex® TreadClimber® Workout on Page 47.
4. When your weight is displayed accurately, push START/STOP one time.
5. Input a Workout Level Setting of 0 for treadmill workout once you have locked the treadles. Remember to change your Workout Level Setting to 0 every time you work out in treadmill mode in order to insure that the CALORIE display accurately shows your calories burned.
6. When your Workout Level is displayed accurately, push START/STOP once again. This will start the clock counting your workout TIME.
7. Press FASTER to start the belts. Starting belt speed is 0.7 mph.
8. Once the belts have started, you may step onto the treadles at any time.

NOTE: If you are new to the TreadClimber® machine, make sure to start your workout at a slower speed, gradually increasing belt speed as your endurance and fitness levels increase.

9. Press FASTER or SLOWER to increase or decrease belt speed as needed.

Starting a Treadmill Workout (TC1000)

1. Make sure you have locked the treadles, following the guidelines in the Locking the Treadles section in this manual.
2. Push START/STOP to start the walking belts (the console will NOT power up if the Safety Key is not properly inserted into the Safety Keyhole)—TIME starts counting as soon as you start the belts. Starting belt speed is 0.5 mph.
3. Once the belts have started, you may step onto the treadles at any time.

NOTE: If you are new to the TreadClimber® machine, make sure to start your workout at a slower speed, gradually increasing belt speed as your endurance and fitness levels increase.

4. Press FASTER or SLOWER to increase or decrease belt speed as needed.

Workout Instructions

Stair-Stepper Workout

Starting a Stair-Stepper Workout (TC3000 and TC5000)

1. Push POWER to turn on the Console (the console will NOT power up if the Safety Key is not properly inserted into the Safety Keyhole).
2. Input your weight. For first time use, follow the weight-input instructions for Starting a Bowflex® TreadClimber® Workout on Page 47.
3. When your weight is displayed accurately, push START/STOP one time.
4. Input your Workout Level Setting. For first time use, follow the Workout Level-input instructions for Starting a Bowflex® TreadClimber® Workout on Page 47.
5. When your Workout Level is displayed accurately, push START/STOP once again. This will start the clock counting your workout TIME.
6. Do not press the FASTER button to start the belts. Instead, start stepping for your stair-stepper workout.

The console will calculate your calories burned for a stair-stepper workout, and the MILES/TOTAL STEPS will show total steps taken.

NOTE: Miles/Total Steps display will toggle between miles and total steps every 6 seconds.

Starting a Stair-Stepper Workout (TC1000)

1. DO NOT press START/STOP.
2. Begin stepping, however, remember that the TIME, SPEED and DISTANCE displays will not display your workout information.

Workout Instructions

Bowflex® TreadClimber® Workout

A TreadClimber® workout combines stair-stepping with moving belts and gently supported resistance, providing you a workout that burns calories faster than almost any cardiovascular exercise machine you have ever experienced. While you may use your TreadClimber® machine in treadmill and stair-stepping modes in addition to the TreadClimber® mode, you will experience the best calorie and fat-burning when working out in TreadClimber® mode.

Starting a TreadClimber® Workout (TC3000 and TC5000)

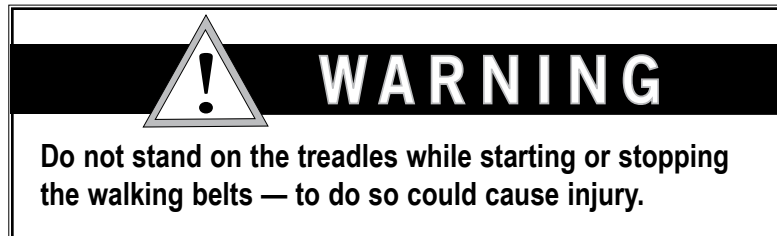

1. Push POWER to turn on the Console. The console will NOT power up if the Safety Key is not properly inserted into the Safety Keyhole.
2. Input your weight.
FOR FIRST TIME USE: A default weight of 150 lbs will show in the digital displays.

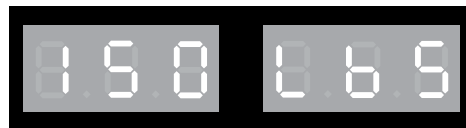

Display: 150 lbs

Use the FASTER or SLOWER buttons to increase or decrease to your actual weight. The TreadClimber® machine will remember the last weight you input and display that weight upon startup the next time you exercise.

3. When your weight is displayed accurately, push START/STOP one time.
4. Input your Workout Level Setting.
FOR FIRST TIME USE: A default workout level of 6 will show in the digital displays.



Display: Workout Level 12

Use the FASTER or SLOWER buttons to change the digital display setting to your actual workout level setting.

NOTE: Actual Workout Level Settings are changed manually, using the Workout Level dials located on each Hydraulic Cylinder, but you will also need to input your Workout Level into the console for calorie burn calculations (see Page 33).

5. When your Workout Level is displayed accurately, push START/STOP once again. This will start the clock counting your workout TIME.

NOTE: Your TreadClimber® machine uses your Workout Level and weight settings to calculate your calories burned. If your Workout Level or weight changes, you must remember to change your settings on the console to insure accurate calorie burn calculation.

Workout Instructions

6. Press FASTER to start the belts. Starting belt speed is 0.7 MPH (1.1 KPH).

NOTE: Belts may take two to three seconds to start.

7. Once the belts have started, you may step onto the treadles at any time.

NOTE: If you are new to the Bowflex® TreadClimber® machine, make sure to start your workout at a slower speed, gradually increasing belt speed as your endurance and fitness levels increase.

8. Press FASTER or SLOWER to increase or decrease belt speed as needed.

Starting a TreadClimber® Workout (TC1000)

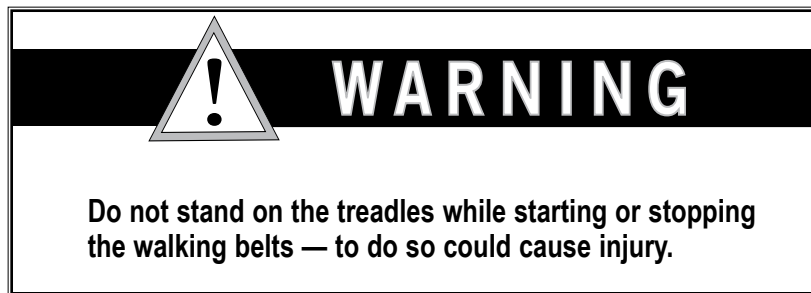

1. Push START/STOP to start the walking belts—TIME starts counting as soon as you start the belts.

NOTE: The console will NOT power up if the Safety Key is not properly inserted into the Safety Keyhole.

2. Once the belts have started, you may step onto the treadles at any time.
3. Press FASTER to increase your speed. Starting belt speed is 0.5 MPH (0.8 KPH).

NOTE: If you are new to the TreadClimber® machine, make sure to start your workout at a slower speed, gradually increasing belt speed as your endurance and fitness levels increase.

4. Press FASTER or SLOWER to increase or decrease belt speed as needed.

Workout Instructions

Preliminary TreadClimber® Workout

First 4 Weeks

Based on your Perceived Exertion Level (see the Determining Your Fitness Level section at the beginning of the Workout Instructions section of this manual), follow the Preliminary Workout guidelines to ease yourself into a weekly Bowflex® TreadClimber® regimen. This regimen may include varying stair-stepper, treadmill and TreadClimber® modes (combination elliptical, stair-stepping and treadmill) workouts or any one of those workouts that suits your own unique and ever-changing exercise-regimen needs.

Remember to always use your own, best personal judgment and the advice of your physician or health care professional to determine how intense and how long your daily workout should be.

Warming Up

Before you begin any workout, you should prepare your body for increased activity by slowly raising your heart rate.

Stair-stepping is one way to warm up your body slowly without fatiguing. Follow the directions in the Stair-Stepper Workout section in this manual to begin a stair-stepper warm-up. When you are ready to begin your TreadClimber® workout, all you will need to do is:

- a) Step off the treadles onto the Side Foot Support Platforms
- b) Engage the belts by pressing the FASTER button (START/STOP for the TC1000)

Beginning Your Workout

Interval Training and Steady State are two types of workouts that you may perform on the TreadClimber® machine while in TreadClimber® mode (stepping and using the belts at the same time). You may also wish to combine Interval Training with Steady State Training to get a varied workout.

Interval Training involves adjusting your speed for specific lengths of time to raise and lower your heart rate and calorie burn. Interval training varies the intensity of your workout during one exercise session. Alternating high-intensity training with low-intensity rest periods will boost your metabolism and help you continue to burn calories even after your workout is over.

Interval training also helps prevent the injuries often associated with repetitive endurance exercise, and allows you to increase your training intensity without over-training or burning out.

Try varying your belt speed or rate of stepping from fast speeds to slower recovery speeds to begin building your own Interval Training regimen.

Steady State workout involves performing one exercise at the same speed and intensity for a long period of time. While there are risks to repetitive workouts, the TreadClimber® machine is designed to cushion your joints and muscles from those stress injuries. Further, repetitive workouts can help you build your endurance, stamina and strength while continuing to hone and improve the tone and lean muscle mass in your long muscles.

Workout Instructions

Beginner Level	Intermediate Level	Advanced Level
Week 1	Week 1	Week 1
<ul style="list-style-type: none"> • 3 x per week – treadmill workout with treadles locked at 2 MPH pace for 30 minutes <p>Once this has become easier, retest your Fitness Level to determine if you are ready to progress to Week 2 – your perceived exertion should have improved at least one point.</p>	<ul style="list-style-type: none"> • 3 x per week, perform a TreadClimber® workout at steady, constant pace for 30 minutes 	<ul style="list-style-type: none"> • 2 days interval training – 30 minutes • 1 day steady pace – 30 minutes <p>Increase workout level setting during training weeks, if needed, to maximize TreadClimber® fitness benefits.</p>
Week 2	Week 2	Week 2
<ul style="list-style-type: none"> • 3 x per week, perform a TreadClimber® workout at steady, constant pace – 30 minutes <p>Once this has become easier, retest your Fitness Level to determine if you are ready to progress to Week 3 – your perceived exertion should have improved at least one point.</p>	<ul style="list-style-type: none"> • 2 days steady pace – 30 minutes • 1 day interval training – 30 minutes <p>Increase your workout levels during training weeks, if needed, to maximize TreadClimber® fitness benefits.</p>	Use Weeks 1 as a guide to help you begin building your own long-term fitness routine, adjusting your interval speeds, resistance, step depth, etc. in order to maximize TreadClimber® benefits.
Week 3	Week 3	
<ul style="list-style-type: none"> • 2 days steady pace – 30 minutes • 1 day interval training – 30 minutes <p>Increase workout level setting.</p>	Use Weeks 1 and 2 as a guide to help you begin building your own long-term fitness routine, adjusting your interval speeds, resistance, step depth, etc. in order to maximize TreadClimber® benefits.	
Week 4		
<ul style="list-style-type: none"> • 2 days interval training – 30 minutes • 1 day steady pace – 30 minutes <p>Increase workout levels 1-2 levels during training weeks, if needed, to maximize fitness benefits.</p>		
Week 5		
Use Weeks 1, 2, 3 and 4 as a guide to help you begin building your own long-term fitness routine, adjusting your interval speeds, resistance, step depth, etc. in order to maximize TreadClimber® benefits.		

Fast Fat Loss Now!



The Bowflex® TreadClimber® Body Leanness Program

By Dr. Ellington Darden



BOWFLEX
TreadClimber™

Body Leanness Program

The following dietary program was created for use with the Bowflex® TreadClimber® exercise machine by Dr. Ellington Darden. Please consult your physician or health care professional before beginning any fitness or dietary program.

Introduction

The TreadClimber® Body Leanness Program

This program is scientifically designed for maximum fat loss over six weeks. It is important that you practice every aspect of the plan to achieve optimum results.

The program separates into three two-week stages. During each stage you will exercise,

control the number and quality of calories you consume and drink plenty of ice-cold water.

Before starting the exercise routine, you must be familiar with your TreadClimber® machine. You should experiment with finding the proper amount of resistance and speed to use during your workouts to remain in your target fat-burning heart-rate zone.



WARNING

Before beginning this program, consult your physician or health care professional and show them this plan.

Only your physician or health care professional can determine if this course is appropriate for your particular age and condition.

If you choose to use this program, you assume all risks, known and unknown, inherent to exercise and workout programs, diet programs, and physical changes or injuries that may result from the use of such programs.

Nautilus, Inc., its subsidiaries and affiliated companies, will not accept any responsibility or liability resulting from your use of the Body Leanness Program. In addition, if you have not already done so, we suggest having a physician or health care professional review the warning for additional contraindications.

If you experience any light-headedness, dizziness, or shortness of breath while exercising, stop the movement and consult a physician or health care professional.

Make sure you read your TreadClimber® Owner's Manual before attempting a workout.

There are a few people who should not try this program: children and teenagers; pregnant women; women who are breast feeding; diabetics; individuals with certain types of heart, liver, or kidney disease; and those suffering from certain types of arthritis. This list is not all-inclusive. Some people should follow the course only with their physician or health care professional's specific guidance.

Play it safe and always consult a physician or health care professional.

Body Leanness Program

Eating Guidelines

You will be following a reduced-calorie nutrition program which is divided into three two-week segments. The program is a proven method for achieving maximum fat loss over a six-week period. It consists of a carbohydrate-rich, descending-calorie eating plan and a super-hydration routine.

Follow a Carbohydrate-Rich, Descending-Calorie Eating Plan:

Approximately 60 percent of your daily calories should be from carbohydrates. The other 40 percent will be equally divided between proteins and fats. The 60:20:20 ratio of carbohydrates, proteins, and fats is ideal for maximum fat loss.

Keep Menus Simple and Food Substitutions to a Minimum:

Research has established that successful dieters prefer the same foods each day for breakfast and lunch. They like variety, however, for dinner. Detailed menus and food choices are included later in this manual.

If you must vary from the menu items, try to stay within the 60:20:20 ratio of carbohydrates, proteins and fats.

For Example			
Daily Amount	Carbohydrate 60%	Protein 20%	Fat 20%
Calories			
2000	1200	400	400
1900	1140	380	380
1800	1080	360	360
1700	1020	340	340
1600	960	320	320
1500	900	300	300
1400	840	280	280
1300	780	260	260
1200	720	240	240
1100	660	220	220
1000	600	200	200

Super-hydrate Your System

Drinking plenty of water is essential to the success of this program. Drinking the recommended amount of water can seem like a challenge at first. Stick with it. Carry a large sports bottle or similar item with you throughout the day. After several weeks, you will find that you actually thirst for more and more water, and the amounts recommended are easily reached.

Super-hydration aids fat loss in a number of ways. First, the kidneys are unable to function without adequate water. When they do not work to capacity some of their load is dumped onto the liver.

This diverts the liver from its primary function, which is to metabolize stored fat into usable energy. Because it's performing the chores of the water-depleted kidneys, the liver metabolizes less fat.

Second, overeating can be averted through water intake, as water can keep the stomach feeling full and satisfied between meals.

Third, ice-cold water requires calories to warm it to core body temperature. In fact, 1 gallon of ice cold water generates 123 calories of heat energy.

You'll be drinking from 1 to 1 5/8 gallons of water each day on the following super-hydration schedule:

Week 1 = drink 4.0 32-oz. bottles of ice-cold water per day.

Week 2 = drink 4.5 32-oz. bottles of ice-cold water per day.

Week 3 = drink 5.0 32-oz. bottles of ice-cold water per day.

Week 4 = drink 5.5 32-oz. bottles of ice-cold water per day.

Week 5 = drink 6.0 32-oz. bottles of ice-cold water per day.

Week 6 = drink 6.5 32-oz. bottles of ice-cold water per day.

Don't be surprised if you have to make more than a dozen trips to the rest room, especially during the first week of the program. Remember, your body is an adaptive system and it will soon accommodate the increased water consumption.



NOTE: Although it is doubtful that you could ever drink too much water, a few ailments can be negatively affected by large amounts of fluid. For example, anyone with a kidney disorder or anyone who takes diuretics, should consult a physician or health care professional before going on the recommended water-drinking schedule. If you have any doubts about the recommendations, play it safe and check with your physician or health care professional.

Body Leanness Program

The Eating Plan

The menus in the Body Leanness Program eating plan are designed for maximum fat-loss effectiveness and nutritional value. For best results, follow them exactly.

Every attempt has been made to utilize current popular brand names and accurate calorie counts, which are listed in the menus. But, as you probably realize, products are sometimes changed or discontinued. If a listed item is not available in your area, you'll need to substitute a similar product. Become an informed label-reader at your supermarket. Ask questions about any products you don't understand. Supermarket managers are usually helpful. If they don't have an answer to your question, they will get it for you.

Each day you will choose a limited selection of foods for breakfast and lunch. Most people can consume the same basic breakfast and lunch for months with little modification. Variety during your evening meal, however, will make daily eating interesting and enjoyable. Additionally, the eating plan includes a mid-afternoon and late-night snack to keep your energy high and your hunger low.

Begin Week 1 on Monday and continue through Sunday. Week 2 is a repeat of Week 1.

The following is the eating plan for the next six weeks (calories for each food are in parentheses), with a Shopping List on Page 51.

Week 1 & 2:

Men – 1500 calories per day.

Women – 1200 calories per day.

Week 3 & 4:

Men – 1400 calories per day.

Women – 1100 calories per day.

Week 5 & 6:

Men – 1300 calories per day.

Women – 1000 calories per day.

You'll always have a 300-calorie breakfast, a 300-calorie lunch, and a 300-calorie dinner (women), or 500-calorie dinner (men). With each two-week descend, only your snack calories will change: from 400 to 300 to 200 calories per day (men), or 300 to 200 to 100 calories per day (women). For each of your five daily meals, you'll have at least three choices.

Everything has been simplified so even the most kitchen-challenged man or woman can succeed. Very little cooking is required. All you need to do is read the menus, select your food choices, and follow the directions. It's as simple as that.

If you find that you wish to vary from the outlined menu items, try to stay within the 60:20:20 ratio of carbohydrates, proteins, and fats.

Body Leanness Program

The Eating Plan

Breakfast = 300 calories.

Choice of bagel, cereal or shake:

Bagel:

1 plain bagel, Sarah Lee® (frozen) (210)
3/4 ounce light cream cheese (45)
1/2 cup orange juice, fresh or frozen (55)
Non-caloric beverage: any beverage without calories, caffeine or sodium, such as decaffeinated coffee or tea.

Cereal:

1.5 ounces (42 grams) serving equals approximately 165 calories.
Choice of one: Kellogg's® Low Fat Granola, General Mills® Honey Nut Clusters or General Mills® Basic 4
1/2 cup skim milk (45)
3/4 cup orange juice (82)
Non-caloric beverage

Shake (choice of one):

Banana – Orange
1 large banana (8 3/4 inches long) (100)
1/2 cup orange juice (55)
1/2 cup skim milk (45)
2 tablespoons wheat germ (66)
1 teaspoon safflower oil (42)
2 ice cubes (optional)
Place ingredients in blender. Blend until smooth.

Chocolate or Vanilla
1 packet Carnation® Instant Breakfast, Champion UltraMet®, or another diet shake powder that contains the appropriate calories (100)

1 cup skim milk (90)
1/2 large banana (8 3/4 inches long) (50)
1 teaspoon safflower oil (42)
1 teaspoon Carnation® Malted Milk powder (20)
2 ice cubes (optional)
Place ingredients in blender. Blend until smooth.

Lunch = 300 calories.

Choice of one of three meals:

Sandwich:

2 slices whole wheat bread (140)
2 teaspoons Promise® Ultra Vegetable Oil Spread (24)
2 ounces white meat (about 8 thin slices), chicken or turkey (80)
1 ounce fat-free cheese (1 1/2 slices) (50)
[Optional: Add to bread 1 teaspoon Dijon mustard (0)]
Non-caloric beverage

Soup (choice of one):

Healthy Choice® Hearty Chicken, 15-ounce can (260), or Campbell's® Healthy Request Hearty Vegetable Beef, 16-ounce can (260)
1/2 slice whole wheat bread (35)
Non-caloric beverage

Chef Salad:

2 cups lettuce, chopped (20)
2 ounces white meat, chicken or turkey (80)
2 ounces fat-free cheese (100)
4 slices tomato, chopped (28)
1 tablespoon Italian, fat-free dressing (6)
1 slice whole wheat bread (70)
Non-caloric beverage

Mid-Afternoon Snack:

Men = 200 calories for Weeks 1 & 2; 150 calories for Weeks 3 & 4; 100 calories for Weeks 5 & 6.

Women = 150 calories for Weeks 1 & 2; 100 calories for Weeks 3 & 4; 50 calories for Weeks 5 & 6.

1 large banana (8 3/4 inches long) (100)
1 apple (3-inch diameter) (100)
1/2 cantaloupe (5-inch diameter) (94)
5 dried prunes (100)
1 ounce (2 small 1/2 ounce boxes) raisins (82)
1 cup light, nonfat, flavored yogurt (100)

Body Leanness Program

Dinner = 500 or 300 calories.

Men = 500 calories, Women = 300 calories

Choice of one of three meals:

Tuna Salad Dinner

In a large bowl, mix the following:

1 6-ounce can chunk light tuna in water (180)
1 tablespoon Hellmann's® Light, Reduced-Calorie Mayonnaise (50)
2 tablespoons sweet pickle relish (40)
1/4 cup whole kernel corn, canned, no salt added (30)
Non-caloric beverage

Men add:

1/2 cup sliced white potatoes, canned (45)
2 slices whole wheat bread (140)

Steak Dinner

3 ounces lean sirloin, broiled (176)
1/2 cup sweet peas, canned, no salt added (60)
1/2 cup beets, canned (35)
1/2 cup skim milk (45)
Non-caloric beverage

Men add:

2 slices whole wheat bread (140)
1 teaspoon Promise® Ultra Vegetable Oil Spread (12)
1/2 cup skim milk (45)

Frozen Microwave Dinner

Choose one of five recommended meals:

Glazed Chicken Dinner, Lean Cuisine® (230)

1/2 cup skim milk (45)
Non-caloric beverage

Men add:

2 slices whole wheat bread (140)
2 teaspoons Promise® Ultra Vegetable Oil Spread (24)
1/2 cup skim milk (45)

Lasagna with Meat Sauce, Lean Cuisine® (240)

1/2 cup skim milk (45)
Non-caloric beverage

Men add:

2 slices whole—wheat bread (140)
2 teaspoons Promise® Ultra Vegetable Oil Spread (24)
1/2 cup skim milk (45)

Macaroni and Cheese, Weight Watchers® (260)

1/2 cup skim milk (45)
Non-caloric beverage

Men add:

2 slices whole—wheat bread (140)
2 teaspoons Promise® Ultra Vegetable Oil Spread (24)
1/2 cup skim milk (45)

Broccoli & Cheddar Cheese Sauce over Baked Potato, Lean Cuisine® Lunch Express (250)

1/2 cup skim milk (45)
Non-caloric beverage

Men add:

2 slices whole-wheat bread (140)
2 teaspoons Promise® Ultra Vegetable Oil Spread (24)
1/2 cup skim milk (45)

Country Inn Roast Turkey Classic, Healthy Choice® (250)

1/2 cup skim milk (45)
Non-caloric beverage

Men add:

2 slices whole-wheat bread (140)
2 teaspoons Promise® Ultra Vegetable Oil Spread (24)
1/2 cup skim milk (45)

Late-Night Snack

Men = 200 calories for Weeks 1 & 2; 150 calories for Weeks 3 & 4; 100 calories for Weeks 5 & 6.

Women = 150 calories for Weeks 1 & 2; 100 calories for Weeks 3 & 4; 50 calories for Weeks 5 & 6.

Mid-Afternoon Snacks on Page 39, plus the following:

1/2 cup low-fat frozen yogurt (100)
2 cups light, microwave popcorn (100)

Body Leanness Program

Shopping List

Quantities for listed items will depend on your specific selections. Review your choices and adjust the shopping list accordingly. It may be helpful for you to photocopy this list each week before doing your shopping.

Staples

Orange juice, skim milk, whole-wheat bread, Promise® Ultra Vegetable Oil Spread, Italian fat-free dressing, Dijon mustard, safflower oil, non-caloric beverages (tea, decaffeinated coffee, diet soft drinks, water).

Grains

Bagels, Sarah Lee® (frozen)

Cereals — 1.5 ounce serving equals approximately 165 calories; Kellogg's® Low-Fat Granola (without raisins), General Mills® Honey Nut Clusters, General Mills® Basic 4.

Wheat germ, malted milk powder, popcorn (microwave light).

Fruits

Bananas, large (8 3/4 inches long), apples (3-inch diameter), cantaloupes (5-inch diameter), dried prunes, raisins.

Vegetables

Lettuce, tomatoes, whole kernel corn (canned no salt added), sweet peas, (canned no salt added), sliced white potatoes (canned), cut beets (canned).

Dairy

Yogurt (light nonfat), cream cheese (light), cheese (fat-free), low-fat frozen yogurt, Carnation® Instant Breakfast packets, Champion UltraMet® Packets.

Meat, Poultry, Fish and Entrees

Chicken (thin sliced), turkey (thin sliced), tuna (canned in water), sirloin steak (lean).

Canned soup

Healthy Choice® Hearty Chicken, Campbell's® Healthy Request Hearty Vegetable Beef.

Frozen microwave dinners or entrees:

Lean Cuisine® Glazed Chicken Dinner, Lean Cuisine® Lasagna with Meat Sauce, Lean Cuisine® Lunch Express Broccoli & Cheddar Cheese over Potato, Weight Watchers® Macaroni and Cheese, Healthy Choice® Grilled Turkey Breast.

Body Leanness Program

Questions & Answers

Q. I often get headaches when I eat only 1000 calories a day. What should I do?

A. Your headaches may be caused by going longer than three hours between meals or snacks. Try spacing your meals and snacks where there are fewer hours between them.

Some people who are used to drinking regular coffee with caffeine notice headaches when they stop consuming coffee for several days. If this is the case with you, you might want to ease off the coffee more gradually.

Q. I don't like red meat. I notice that the Lean Cuisine® Lasagna with Meat Sauce contains beef. What can I substitute for it?

A. Lean Cuisine® has many other frozen dinners that you may substitute for Lasagna with Meat Sauce. Try to find one that contains the same calories, with approximately 15 to 20 percent of the calories coming from fat. Some of the Lean Cuisine® dinners actually have too little fat for my nutritional requirements.

Q. May I have dinner for lunch and lunch for dinner?

A. Yes.

Q. I tend to get a headache when I drink cold water. Can I drink water without it being chilled?

A. Yes, but you won't get the 123 calories or more thermogenic effect from warming the cold water to core body temperature. Try a more gradual drinking of the cold water. You may have been consuming it too quickly.

Q. Is it possible to drink too much water?

A. Certainly. To do so, however, you'd probably have to drink four or five times as much per day as I'm recommending. There are a few ailments that can be negatively affected by large amounts of fluid. If you feel you have a problem, check with your doctor before starting the program.

Q. Is bottled water better than tap water?

A. Research shows that bottled water is not always higher quality water than tap water. The decision to drink bottled water or not is usually one of taste. If you dislike the taste of your tap water, then drink your favorite bottled water. But first you might want to try a twist of lemon or lime added to the water from your tap. Some people say it makes a significant difference in the taste.

Q. I'm a middle-aged woman who gets black and blue marks on my legs when I diet. Am I doing anything wrong?

A. I doubt you are doing anything wrong. Such black and blue marks are usually the result of an increased level of estrogen circulating in your body, which weakens the walls of the capillaries and causes them to break under the slightest pressure. When this happens, blood escapes and a bruise occurs. Estrogen is broken down in the liver, and so is fat. When you are dieting, your liver breaks down the fat, leaving a lot more estrogen in the bloodstream.

It may be helpful to supplement your diet with a little extra vitamin C each day to help toughen the walls of the capillaries.

Body Leanness Program

Q. I'm a 40-year-old woman with a teenage son and daughter. My husband and I both want to lose 10 pounds and the children would also like to lose some weight. Can I put the whole family on the program?

A. It would be great if you could, but you cannot. The number of calories per day is the problem. Teenagers require significantly more calories each day than 1500, which is the highest level. Check with a registered dietician (RD) for appropriate recommendations.

Q. What happens after six weeks? How do I continue the program if I need to lose more weight?

A. You should repeat the program for as long as it takes you to reach your goal. There are, however, a few guidelines and modifications to apply.

Repeat the eating plan exactly as before: Men, go back to 1500 calories a day for two weeks. Women, go back to 1200 calories a day for two weeks. Then, descend your calories in the same manner.

Keep your super-hydration schedule at the highest level. In other words, sip 1 5/8 gallons of ice-cold water each day.

Q. I'm pleased that I lost the fat I wanted to lose. What do I do to maintain my new body weight?

A. Once you've lost your excessive fat, your next task is to maintain that status. The following section shows the adjustments you need to make to your current practices.

Maintaining Your Lean Body

Adhere to a carbohydrate-rich, moderate-calorie eating plan.

Instead of eating from 1000 to 1500 calories a day, you'll be consuming from 1600 to 2400 calories per day. Maybe you can eat even more after your new body weight has stabilized. Trial-and-error experimentation is a must. Women should start with 1600 calories, and men with 2000 calories per day. Note what happens after a week. If your body weight keeps going down, raise the calories by 100 or 200; depending on how much weight you lost during the last week.

Soon, you should reach a level where your body weight stabilizes. That level is your daily calorie requirement. Naturally, you'll be able to consume other foods than those listed in the Body Leanness Program eating plan. By then, however, you should know the value of being a smart shopper and a wise eater. Read labels. Compare nutritional information. Be conscious of the ideal 60:20:20 ratio for carbohydrates, proteins, and fats.

Eat smaller meals more frequently.

You've been limiting your five meals per day to 300 calories if you're a woman, or 500 calories if you're a man. You may now up the calories by 100. What happens if during a single meal you eat more than 400 calories if you're a woman, or 600 calories if you're a man? Don't panic. Simply understand that you will sometimes backslide. Learn to anticipate these urges and take corrective action.

Drink at least 1 gallon of cold water each day.

You should realize by now the benefits of consuming plenty of water each day. Make your water bottle a permanent part of your lifestyle.

Repairs/Maintenance

The following information contained in the Repairs/Maintenance section is provided as a tool to make owning your TreadClimber® machine an exceptional experience.

Contacting Customer Service

TreadClimber® Representatives are able to assist you with service questions and ordering replacement parts. Contact them at: 1-800-NAUTILUS (1-800-628-8458).

Ordering Replacement Parts

Call a Bowflex® TreadClimber® Representative at 1-800-NAUTILUS (1-800-628-8458) to order replacement parts and get assistance with your specific replacement or service requirements.

Refer to the TreadClimber® Parts Reference Guide, and Hardware and Tool List in the Assembly Guide section of this manual, or the Parts exploded views in the Repairs/Maintenance section of this manual when ordering parts.

Routine Maintenance

For general routine maintenance and cleaning see the Care of Your TreadClimber® Exercise Machine section of this manual.

ATTENTION

The Bowflex® TreadClimber® machine's safety and integrity can only be maintained when it is regularly examined for damage and immediately repaired.

It is the sole responsibility of the owner to ensure that regular maintenance is performed. Worn or damaged components still under warranty must be replaced immediately and the TreadClimber® machine shall remain unused until the required repair is made. Only manufacturer-supplied or approved components shall be used to maintain and repair the TreadClimber® machine.

ALWAYS UNPLUG YOUR TREADCLIMBER MACHINE FROM THE OUTLET BEFORE CLEANING OR SERVICING THE UNIT.

Repairs/Maintenance

ATTENTION

Never attempt to make any diagnostic repairs on your own – always call a Bowflex® TreadClimber® Representative at 1-800-NAUTILUS (1-800-628-8458) and allow them to guide you through the diagnostic process.

WARNING

To avoid electrical shock or burn, disconnect power cord and wait five minutes before servicing this machine!

TC5000 and TC3000 Diagnostics

How to access the TC5000/TC3000 LED Board

It is possible that you will need to be able to locate the Lower LED Board during a service call to a TreadClimber® Representative at 1-800-NAUTILUS (1-800-628-8458).

The TC5000 Lower LED Board is located behind the right Plastic Drive Cover. Remove the right Plastic Drive Cover by using a #2 Phillips head screwdriver to unscrew the (3) #10 Phillips head screws attaching the Drive Cover to the base. Gently pull the right Plastic Drive Cover from the base of the unit, carefully setting the Drive Cover and the screws aside until you have completed your diagnostics with a TreadClimber® Representative.

Once you remove the Drive Cover, you will see the LED board.

A TreadClimber® Representative at 1-800-NAUTILUS (1-800-628-8458) will help you locate the Lower LED Board lights and guide you through basic diagnostic maintenance from this point—never attempt to repair or diagnose the TreadClimber® Machine without making a call to a TreadClimber® Representative.

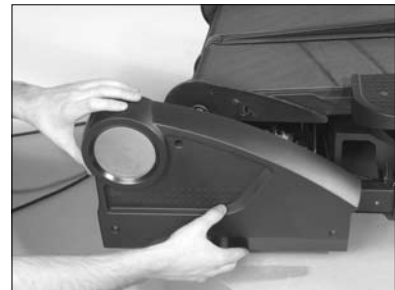

Removing the Right Plastic Drive Cover



Lower LED Board

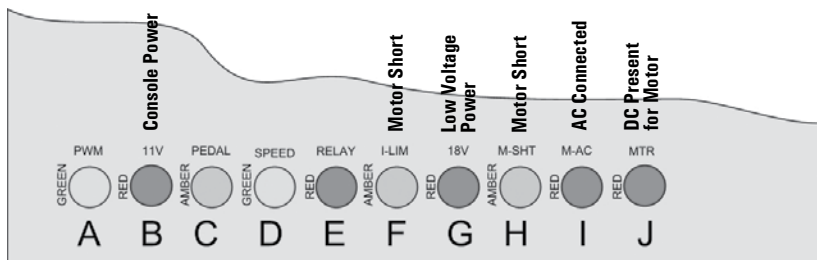

Lower LED Board Lights

Parts

Ordering Replacement Parts

Call a Bowflex® TreadClimber® Representative at 1-800-NAUTILUS (1-800-628-8458) to order replacement parts and get assistance with your specific replacement or service requirements.

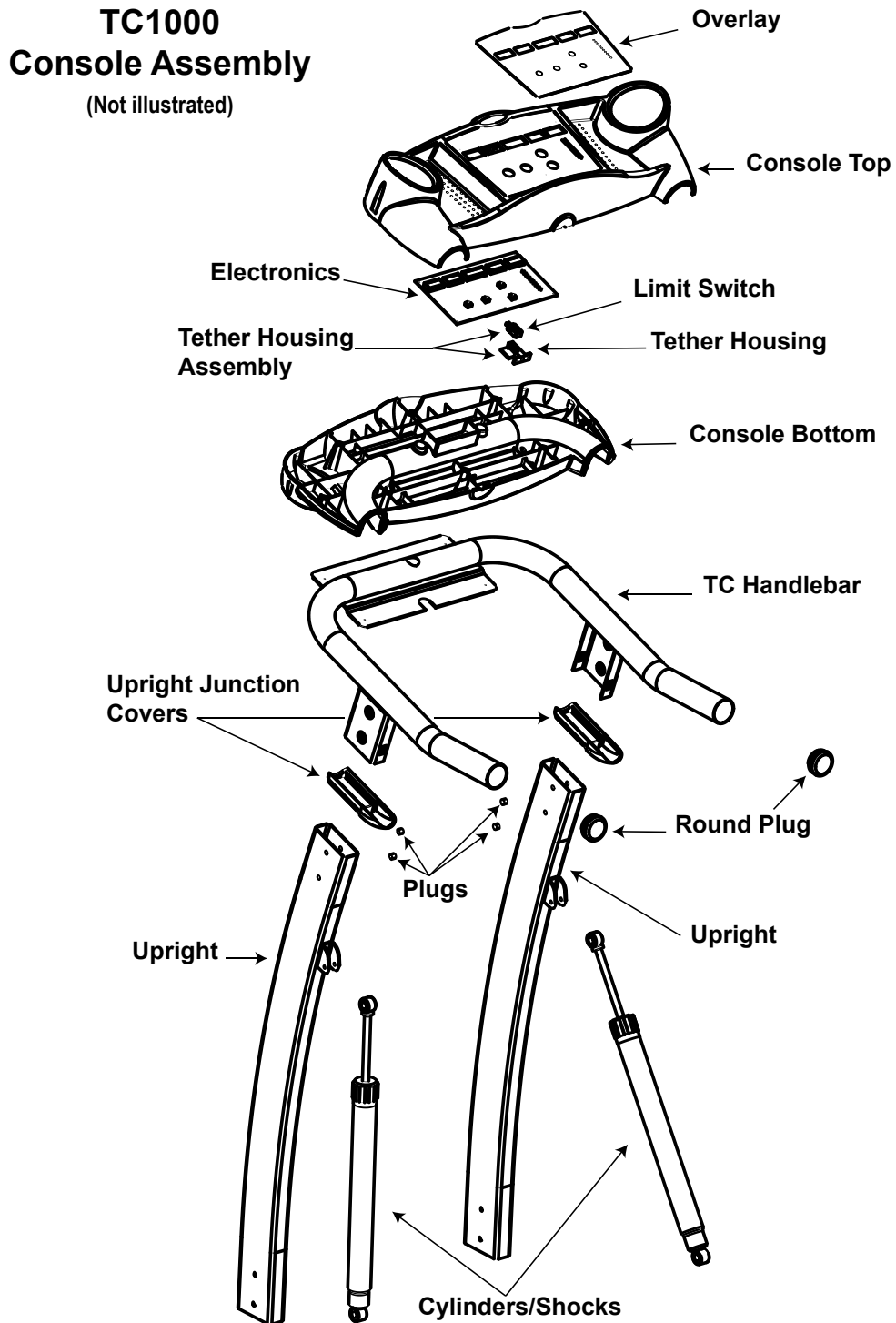

Parts

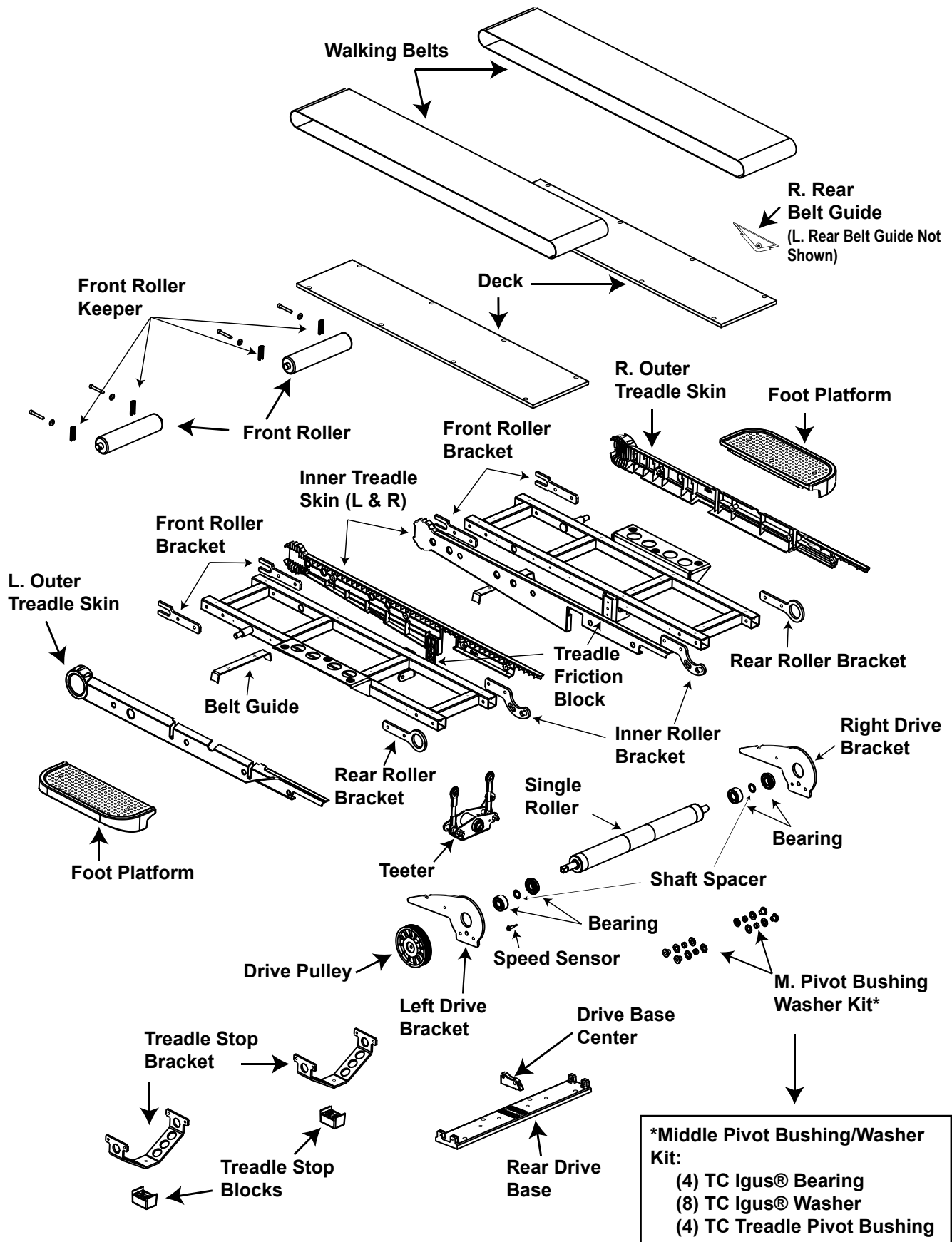

Parts

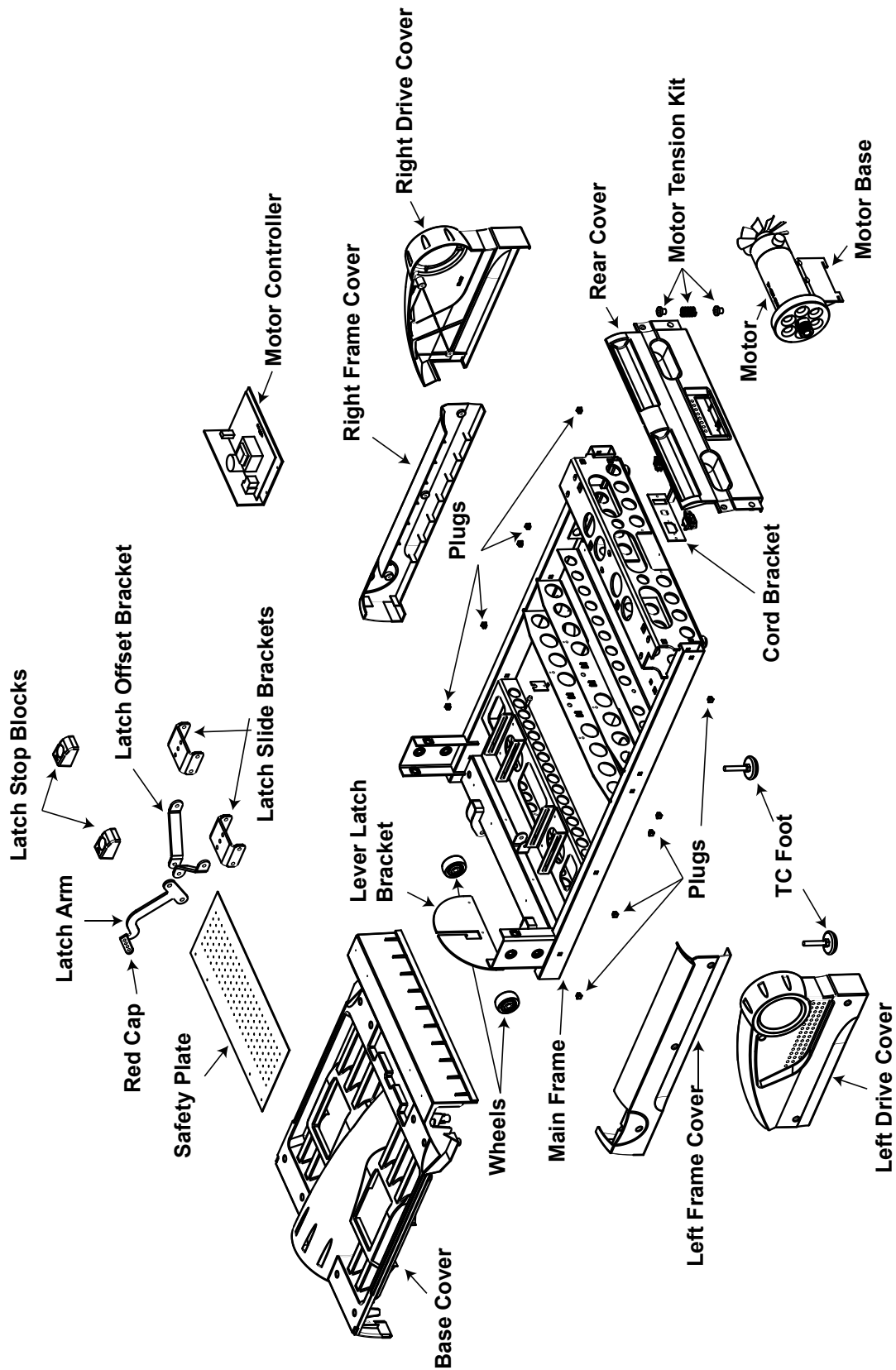

IMPORTANT CONTACT NUMBERS

If you need assistance, please have both the serial number of your machine and the date of purchase available when you contact the appropriate Nautilus office listed below.

OFFICES IN THE UNITED STATES:

- TECHNICAL/CUSTOMER SERVICE
Nautilus, Inc.
World Headquarters
16400 SE Nautilus Drive
Vancouver, Washington, USA 98683
Phone: 800-NAUTILUS (800-628-8458)
Email: customerservice@nautilus.com
Fax: 800-523-1049
- CORPORATE HEADQUARTERS
Nautilus, Inc.
World Headquarters
16400 SE Nautilus Drive
Vancouver, Washington, USA 98683
Phone: 800-NAUTILUS (800-628-8458)

For technical assistance and a list of distributors in your area, please call or fax one of the following numbers.

INTERNATIONAL CUSTOMER SERVICE:

- INTERNATIONAL OFFICE
Nautilus International S.A.
Rue Jean Prouvé 6
1762 Givisiez / Switzerland
Tel: + 41-26-460-77-77
Fax: + 41-26-460-77-70
Email: technics@nautilus.com

INTERNATIONAL OFFICES:

- SWITZERLAND OFFICE
Nautilus Switzerland S.A.
Tel: + 41-26-460-77-66
Fax: + 41-26-460-77-60
- GERMANY and AUSTRIA OFFICE
Nautilus GmbH
Tel: +49-2204-610-27
Fax: +49-2204-628-90
- ITALY OFFICE
Nautilus Italy s.r.l.
Tel: +39-031-51-10-86
Fax: +39-031-34-24-97
- UNITED KINGDOM OFFICE
Nautilus UK Ltd.
Tel: +44-1908-267-345
Fax: +44-1908-267-346
- CHINA OFFICE
Nautilus Representative Office
Tel: +86-21-523-707-00
Fax: +86-21-523-707-09



BOWFLEX
TreadClimber

Customer Service
1.800.NAUTILUS
(800.628.8458)

www.BowflexTreadClimber.com

©2006. Nautilus, Inc. All Rights Reserved. Nautilus, Inc., World Headquarters, 16400 S.E. Nautilus Drive, Vancouver, Washington, USA 98683. TreadClimber, Bowflex, and the Bowflex Logo are either registered trademarks or trademarks of Nautilus, Inc. All marks not listed above are either registered trademarks or trademarks of their respective companies.

Printed in China.

P/N: FF2922 Rev. C (05/06)

Free Manuals Download Website

<http://myh66.com>

<http://usermanuals.us>

<http://www.somanuals.com>

<http://www.4manuals.cc>

<http://www.manual-lib.com>

<http://www.404manual.com>

<http://www.luxmanual.com>

<http://aubethermostatmanual.com>

Golf course search by state

<http://golfingnear.com>

Email search by domain

<http://emailbydomain.com>

Auto manuals search

<http://auto.somanuals.com>

TV manuals search

<http://tv.somanuals.com>