

## Air-Cooled Condensing Units

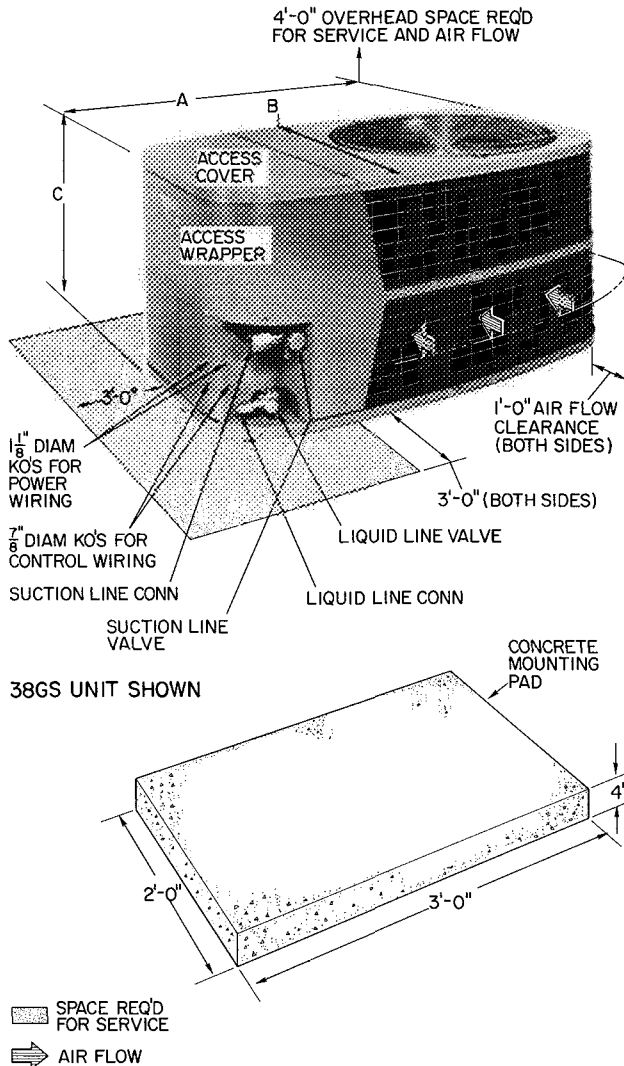

**Fig. 1 – Dimensions, Connections and Mounting Pad  
38GS,CC,CE Unit**

**Table 1 – Installation Data**

	38GS	014	018	024	030	036	042	048	060†
<b>COND UNIT</b>	38CC	—	—	—	030	036	042	048	060†
	38CE	—	—	—	002*	003	004	045	005
<b>OPER WT (lb)</b>		130	135	142	149	158	191	193	200
<b>UNIT DIM. (ft-in.)</b>									
Length	A	2-10 <sup>3</sup> / <sub>4</sub>							
Width	B	1-10							
Height	C	1-4	1-4	1-4	1-4	1-4	2-0	2-0	2-0
<b>REFRIG CONN. (in.)</b>		Compatible Fittings							
Suction (ODF)		5/8	5/8	5/8	3/4*	3/4	3/4	3/4†	3/4†
Liquid (ODF)		3/8							

\*5/8-in suction connection on 38CE002

†38CE045,005 and 38GS,CC060 are factory supplied with 3/4- to 1 1/8-in suction valve adapter (field installed) for 1 1/8-in suction line

### TRANSPORTATION DAMAGE

File claim with shipping company if shipment is damaged or incomplete.

**Unpackaging Unit** – Move condensing unit to final location. Open carton at end marked “compressor end.” Slide unit from carton taking special care to not damage service valves or grilles.

### PRELIMINARY SURVEY

Consult local building codes and National Electrical Code (NEC) for special installation requirements.

When installing unit, allow sufficient space for air flow clearance, wiring, refrigerant piping and servicing unit. Position unit so water from roof or eaves does not flow directly on top of unit.

Install unit on a solid, level mounting pad. Unit can be attached to pad with a mastic adhesive or by drilling holes in base pan for 1/4-in. mounting bolts. Do not block base pan water drainage holes.

**38GS,CC,CE Condensing Units Connected to Carrier Matched Evaporators with Carrier Accessory Tubing** – Check system refrigerant charge when tubing lengths are above or below 25 feet. See Refrigerant Charging (page 10) for details.

**38GS,CC,CE Condensing Units Connected to Non-Carrier Evaporators** – Check refrigerant charge when condensing unit is added to a system in which other than a Carrier approved evaporator is being used or where the evaporator has been previously installed. Field-supplied refrigerant piping must be in accordance with Field-Supplied Piping Data, Table 3.

Where indicated on Table 3 for 38GS,CE units, install a liquid line filter-drier and accessory crankcase heater on condensing unit. (Filter-drier is factory supplied on CE045,005 units.) Accessory start capacitor and relay also required on 38GS units, but not normally required on 38CE units. See Compressor Service (page 7). All above items are standard or not required for 38CC units.

Use an evaporator coil with a bleed-type expansion device. If coil does not have a bleed-type expansion device it may be necessary to add an accessory start capacitor and relay to condensing unit. This would require removing compressor start thermistor (PTC device) on units so equipped.

Table 2 – Accessories

PART NUMBER	DESCRIPTION						USAGE					
HH01AD040 HH93AZ040 HH51AR001	Low-Voltage Control – Honeywell Deluxe Thermostat Thermostat Subbase Comfort Control Center (Use with HH01AD040)						38GS,CC,CE					
HH07AT070, HH07AT074 HH93AZ076	Low-Voltage Control – Honeywell Thermostat Thermostat Subbase (with Automatic Changeover)											
HH01AD042 HH93AZ042	Low-Voltage Control – Honeywell Thermostat Thermostat Subbase											
HH01YA092 HH93YZ094	Low-Voltage Control – Grayson Thermostat Thermostat Subbase											
32LT900301 (200-3 Ph) 32LT900601 (460-3 Ph)	Solid State Head Pressure Control									38CC – (Fan motor suitable for 32LT)		
38GS900102	Indoor Fan Relays (Six HH61KJ210)									38GS,CC,CE		
38GS900212	40VA Low-Voltage Control Transformers (24 v – Six 38GS900091)						38GS,CC,CE					
38GS900112	Crankcase Heaters (Six 38GS900131)						38GS (except 38GS014), 38CE					
38GS900292	Crankcase Heaters (Six 38GS900281)						38GS014					
38GS900172	Start Capacitor and Relay Package (Six 38GS900041)						38GS (except 38GS042), 38CE					
38GS900182	Start Capacitor and Relay Package (Six 38GS900051)						38GS042					
<b>Tubing Packages</b>												
		Liquid			Suction*		UNIT					
	Lgth (ft)	OD (in.)	Tube End OD (in.)	OD (in.)	Tube End OD (in.)		38GS	38CC	38CE			
					Evap	Cond						
38GC900031	10	3/8	3/8	5/8	3/4†	5/8	014,018,024	–	002			
38GC900071	10	3/8	3/8	3/4	3/4	3/4	030,036,042,048	030,036,042,048	003,004,045,005			
38GC900041	18	3/8	3/8	5/8	3/4†	5/8	014,018,024	–	002			
38GC900081	18	3/8	3/8	3/4	3/4	3/4	030,036,042,048	030,036,042,048	003,004,045,005			
38GS900221	25	3/8	3/8	5/8	3/4†	5/8	014,018,024	–	002			
38GC900091	25	3/8	3/8	3/4	3/4	3/4	030,036,042,048	030,036,042,048	003,004,045,005			
38GC900061	35	5/16	3/8	5/8	3/4†	5/8	014,018,024	–	002			
38GC900101	35	3/8	3/8	3/4	3/4	3/4	030,036,042,048	030,036,042,048	003,004,045,005			
38GC900191	50	1/4	3/8	5/8	3/4†	5/8	014,018,024	–	002			
38GC900111	50	3/8	3/8	3/4	3/4	3/4	030,036,042,048	030,036,042,048	003,004,045,005			

\*All suction lines have a 90° bend at one end

†For 5/8-in. evaporator connection, cut off 3/4-in. end

**PIPING CONNECTIONS**

Condensing units can be connected to evaporator sections using Carrier accessory tubing package or field-supplied tubing of refrigerant grade. (Accessory tubing not available for 38GS060, 38CC060.) See Table 2 for accessory tubing sizes and Table 3 for recommended field-supplied tubing sizes. Where evaporator is 20 ft or more below condensing unit, reduce liquid line size one diameter (min 1/4-in. OD).

A capacity reduction will result if accessory tubing is used in 38CE045,005 systems. For example, when a 25 ft accessory tubing package is used, there will be a capacity reduction of 3 3/4% on 38CE045 and 5% on 38CE005 systems. For maximum capacity from these systems, use tubing sizes shown in Table 3.

When other than 25 ft of interconnecting tubing is used, follow special requirements described in Refrigerant Charging. Do not use less

than 10 ft of liquid line. Do not cut 5/16-in. or 1/4-in. liquid line. Bend or coil to fit.

Do not use damaged or contaminated tubing. If accessory tubing package or evaporator section has been open for more than 15 seconds per connection, evacuate or purge evaporator coil and tubing system (use field-supplied refrigerant, not unit refrigerant). Always evacuate or purge if field-supplied tubing is used.

**Before Connecting Unit Piping,** consider the following:

**38CE045,005 AND 38CC UNITS** – A filter-drier package is shipped with these units. Included with filter-drier are 2 short length tubing assemblies that are equipped with flare and/or Compatible Fittings. Use tubing assemblies to install filter-drier into system liquid line at evaporator or condensing unit. See Fig. 2. Connect tubing assembly A (90° assembly) to evaporator or condensing unit liquid line Compatible Fitting. Complete the filter-drier installation as shown.

**Table 3 – Field-Supplied Piping Data**

COND UNIT	REFRIG CONTROL	MAX COND UNIT HT (ft)		REFRIGERANT LINE LENGTH (ft)									
		Above Evap	Below Evap	25-50		51-75		76-100		101-125		126-150	
				Suct	Liq	Suct	Liq	Suct	Liq	Suct	Liq		
38GS014, 38GS018	TXV	90	90										
	Cap. Tube or AccuRater™	150	50	5/8	3/8	5/8	3/8	5/8	3/8	5/8	3/8	5/8	3/8
38GS024	TXV	90	90										
	Cap. Tube or AccuRater	150	50	5/8	3/8	5/8	3/8	5/8	3/8	5/8	3/8	5/8	3/8
38GS030, 38CC030, 38CE002	TXV	90	90										
	Cap. Tube or AccuRater	150	50	3/4	3/8	3/4	3/8	3/4	3/8	3/4	3/8	3/4	3/8
38GS036, 38CC036, 38CE003	TXV	90	90										
	Cap. Tube or AccuRater	150	50	3/4	3/8	3/4	3/8	3/4	3/8	3/4	3/8	3/4	3/8
38GS042, 38CC042, 38CE004	TXV	90	90										
	Cap. Tube or AccuRater	150	50	3/4	3/8	3/4	3/8	3/4	3/8	3/4	3/8	3/4	3/8
38GS048, 38CC048	TXV	90	90										
	Cap. Tube or AccuRater	150	50	3/4	3/8	3/4	3/8	3/4	3/8	3/4	3/8	1 1/8	3/8
38CE045	TXV	90	90										
	Cap. Tube or AccuRater	150	50	1 1/8	3/8	1 1/8	3/8	1 1/8	3/8	1 1/8	3/8	1 1/8	3/8
38GS060, 38CC060, 38CE005	TXV	90	90										
	Cap. Tube or AccuRater	150	50	1 1/8	3/8	1 1/8	3/8	1 1/8	3/8	1 1/8	3/8	1 1/8	3/8

Cranks case heater and liquid line filter-drier required on 38GS and 38CE units. Accessory start capacitor with relay also required on 38GS unit, but not normally required on 38CE units. See Compressor Service. Reduce liquid line diameter by 1/8-in. OD (min 1/4-in. OD) when evaporator is 20 ft or more below condensing unit.

**Cap. Tube** – Capillary Tube  
**TXV** – Thermal Expansion Valve

**NOTES**  
 1 The following system modifications are required: adjust refrigerant charge on systems with over 25 ft separation

between condensing unit and evaporator (See Refrigerant Charging). Adjust system oil charge as described in Note 2.

2 Oil charge adjustment: add 1% of nominal oil charge in system (Table 7) for each 10 ft of refrigerant line length above 50 feet. For example, a system that has a 50-oz oil charge with 150 ft of interconnecting piping requires 5 oz of additional oil as shown below:

$$150 \text{ ft} - 50 \text{ ft} = 100 \text{ ft}$$

$$100 \text{ ft} \div 10 \text{ ft} = 10 \text{ ft}$$

$$10 \times 1\% = 10\% (10)$$

$$10 \times 50 \text{ oz} = 5 \text{ oz}$$

3 Do not permit condensing unit to short cycle, particularly on applications with long vertical line lengths. Correct short cycling condition immediately.

**Connection Procedure** – When making tubing connections, be sure to provide clearance at unit for electrical connections.

Connect refrigerant liquid and suction lines to condensing unit, Fig. 1. Unit Compatible Fittings permit 2 methods of refrigerant line connection: mechanical (quick connect) or sweat connection. Make suction line connection first.

**38CE045,005, 38GS060 AND 38CC060 UNITS** – Remove suction line adapter taped to compressor suction line. Connect 3/4-in. end of adapter to unit suction line Compatible Fitting. Sweat connect refrigerant suction line to 1 1/8-in. end of adapter. Connect liquid refrigerant line to unit.

**MECHANICAL CONNECTION** (Mate one set of connections at a time.)

1. Loosen nut on Compatible Fitting one turn. Do not remove.
2. Remove plug and be sure O-ring is in the groove inside the Compatible Fitting.
3. Cut tubing to correct length.
4. Use gage on tag attached to service valve to mark tube end for correct insertion depth. Insert tube into Compatible Fitting until it bottoms. (Tube should be inserted at least as far as mark on tubing.)
5. Tighten nut until it *bottoms* on back coupling flange.

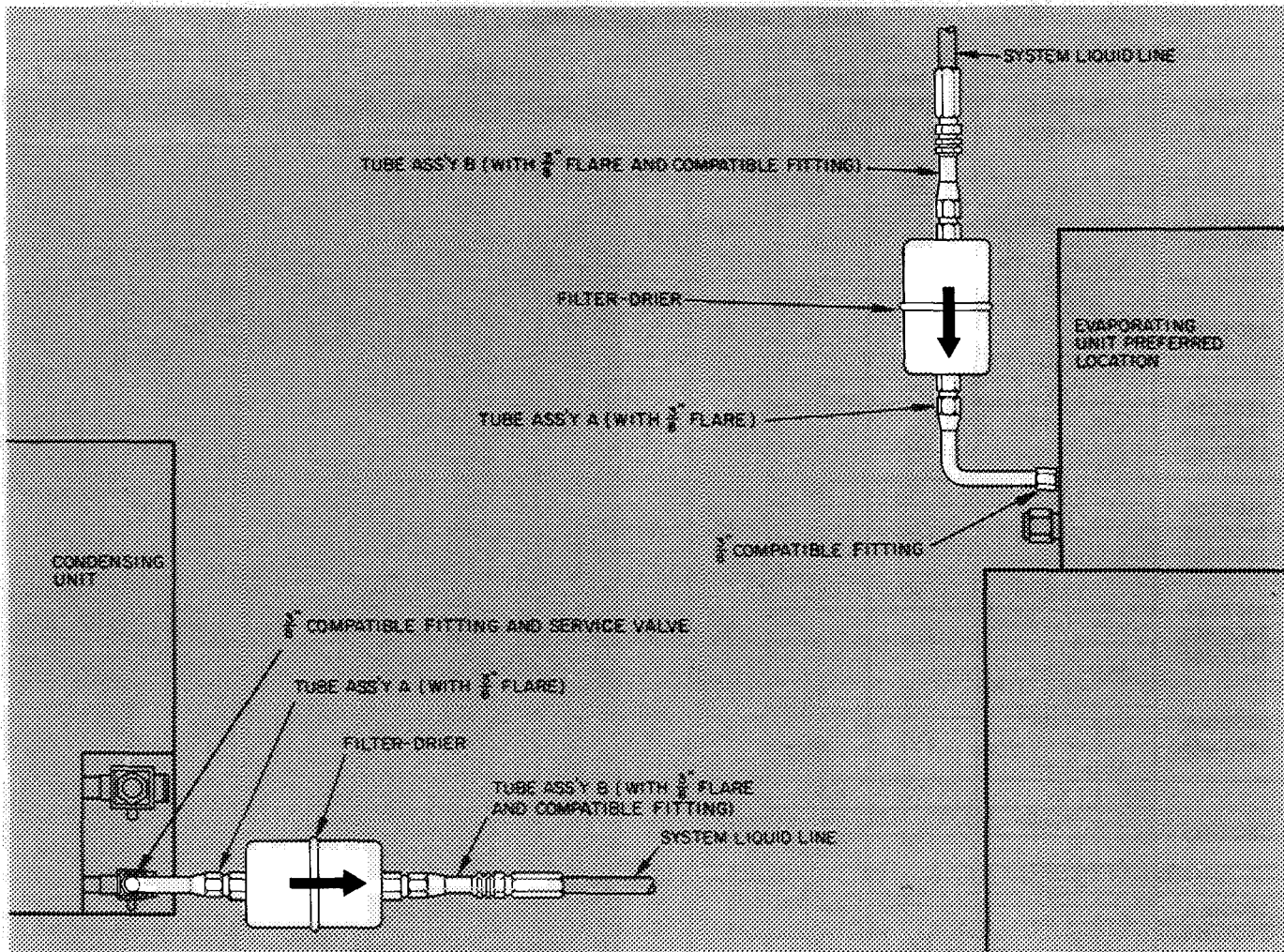

Fig. 2 – Filter-Drier Assembly Installation (38CC, 38CE045 and 005)

SWEAT CONNECTION (Use refrigerant grade tubing.)

1. Remove locking nut, rubber O-ring and Schrader core from valve.
2. Cut tubing to correct length.
3. Insert tube into Compatible Fitting. Wrap top and bottom of service valves in wet cloth to prevent damage by heat. Solder with low temperature (450 F) silver alloy solder.
4. Replace Schrader core.
5. Evacuate or purge system with field-supplied refrigerant.

### ELECTRICAL DATA AND WIRING

Field wiring must comply with local and national fire, safety and electrical codes. Voltage to unit must be within  $\pm 10\%$  of voltage indicated on nameplate. Contact local power company for correction of improper line voltage.

Operation of unit on improper line voltage constitutes abuse and is not covered by Carrier Warranty.

When making electrical connections, provide clearance at unit for refrigerant piping connections. See Table 4 for recommended wire and fuse sizes.

**Install a Branch Circuit Fused Disconnect** of adequate size to handle unit starting current. Locate disconnect within sight of and readily accessible from the unit, per section 440-14 of National Electrical Code (NEC).

**Bring Line Power Leads Into Unit** – Extend leads from fused disconnect thru hole provided in service embossment (Fig. 1) and thru 7/8-in. hole into control box.

**Connect Ground Lead to a Ground Lug in Control Box** for safety. Connect power wiring. See Fig. 3. Splice line power leads to red and violet pigtailed on 38GS,CE units or to yellow pigtailed (3) on 38CC units. Use wire nuts supplied with unit. Tape each connection. Wire nuts are suitable for copper or aluminum wire since they contain joint compound.

**Control Power** (24 v) wiring is brought thru hole in service embossment and spliced to yellow pigtailed on all units. See Fig. 4.

*Furnace or fan-coil transformer must be used as 24-v supply for system as shown in Fig. 4 (At least a 40-va transformer is recommended.)* Current 38GS048,060 and 38CC048,060 units are equipped with a low-voltage transformer used to power contactor thru unit control circuit. This transformer must not be used for powering the indoor thermostat control circuit.

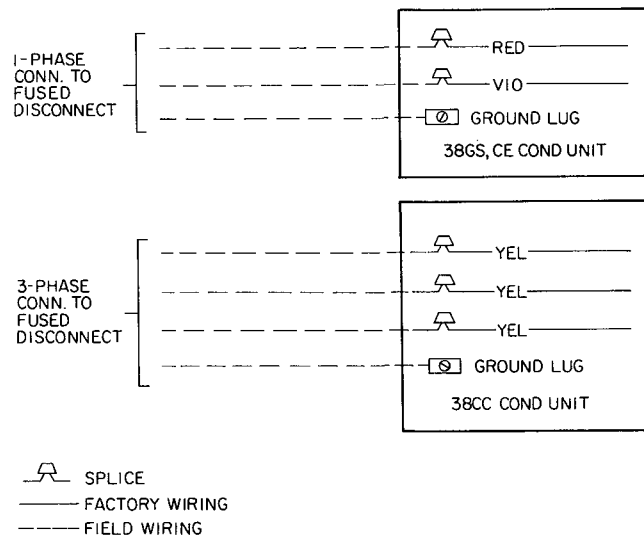
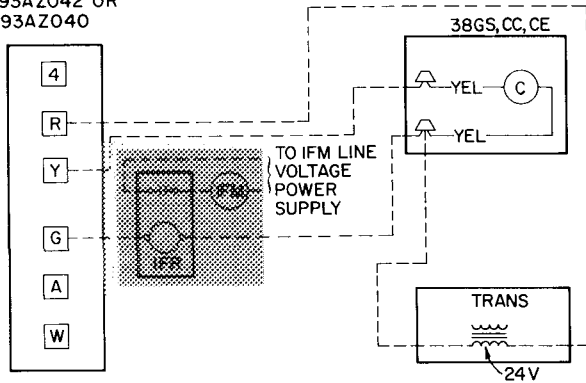

Fig. 3 – Line Power Connections

THERMOSTAT SUBBASE  
HH93AZ042 OR  
HH93AZ040



ARRANGEMENT A-  
(COOLING ONLY)

THERMOSTAT SUBBASE  
HH93AZ042 OR  
HH93AZ040

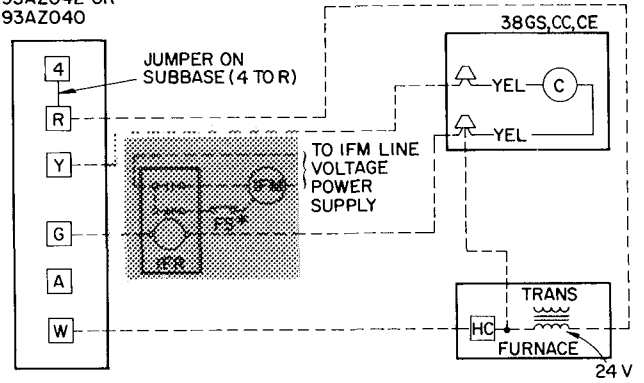

ARRANGEMENT B-  
ONE TRANSFORMER  
(COOLING AND ONE-STAGE HEATING)

\*CONNECT FS TO LOW-SPEED INDOOR FAN TERMINAL WHEN 2-SPEED FAN IS USED

THERMOSTAT SUBBASE  
HH93AZ076

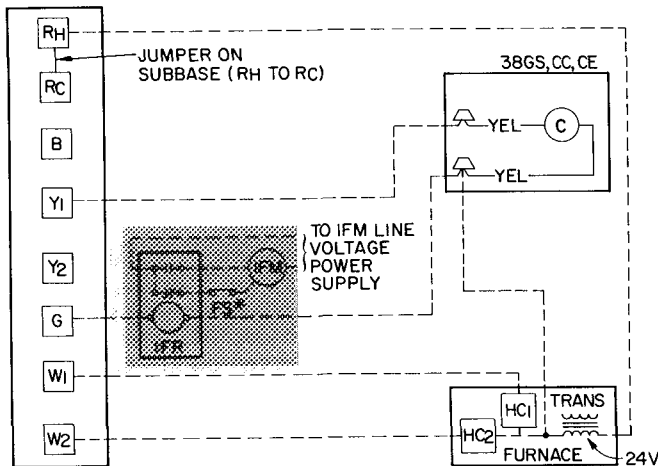

ARRANGEMENT C-  
ONE TRANSFORMER  
(COOLING AND 2-STAGE HEATING)

\*CONNECT FS TO LOW-SPEED INDOOR FAN TERMINAL WHEN 2-SPEED FAN IS USED

IFR, FS and IFM are located in furnace on heating-cooling applications. If accessory IFR is required for cooling only applications, locate (IFR) in fan coil

- C — Control Relay (10 va) or Contactor
- FS — Fan Switch
- HC — Heating Control
- IFM — Indoor Fan Motor
- IFR — Indoor Fan Relay
- Trans — Transformer

- Field Splice
- Field Wiring
- Factory Wiring

Fig. 4 – Control Circuit Connections

Table 4 – Electrical Data

MODEL 38GS	V/PH	OPER* VOLTS		COMPR		FAN	BRANCH CIRCUIT		
		Max	Min	LRA	FLA	FLA	Wire Size† (AWG)	Max Ft Wire†	Fuse‡ Amps
014---	208/1	229	187	42	9.2	2.4	14	40	20
014---	230/1	253	207	42	7.7	2.1	14	33	20
018---	208/1	229	187	60	14.0	2.4	12	28	30
018210				65	10.3	2.4	12	37	20
018---	230/1	253	207	51	12.0	2.1	12	36	25
018310				65	10.3	2.1	14	19	25
024---	208/1	229	187	72	16.0	2.4	10	40	35
024210				80	18.2	2.4	10	35	40
024---	230/1	253	207	62	14.2	2.1	12	31	30
024310				72	14.2	2.1	12	31	30
030---	208/1	229	187	93	22.7	2.4	8	45	50
030210				99	22.5	2.4	8	45	50
030---	230/1	253	207	86	21.4	2.1	10	34	30
030310				88	19.8	2.1	10	36	45
036---	208/1	229	187	106	23.5	2.4	8	44	55
036210				112	28.5	2.4	8	36	65
036---	230/1	253	207	102	22.2	2.1	10	33	50
036310				100	22.2	2.1	10	33	50
042---	230/1	253	207	111	28.0	2.1	8	41	65
048---	230/1	253	207	100	27.9	2.1	8	42	55
060---	230/1	253	207	135	33.5	2.1	6	54	75
<b>38CC</b>									
030---	200/230/3	253	180	70/60	13.0/11.5	2.0/2.0	12	49	30/25
036---	200/230/3	253	180	80/70	14.0/12.6	2.0/2.0	12	45	30/30
036---	460/3	506	414	35	6.5	1.0	14	91	15
042---	200/3	220	180	92	17.0	2.0	10	49	35
042---	230/3	253	207	92	15.8	2.0	10	58	35
042---	460/3	506	414	46	7.8	1.0	14	100	15
048---	200/3	220	180	90	18.6	2.0	10	46	40
048---	230/3	253	207	78.5	16.1	2.0	10	60	35
048---	460/3	506	414	39.3	8.3	1.0	14	100	20
060---	200/3	220	180	110	23.0	2.0	8	67	50
060---	230/3	253	207	100	20.5	2.0	10	47	45
060---	460/3	506	414	50	10.3	1.0	14	74	20
<b>38CE</b>									
002---	230/1	253	207	65	10.3	2.1	12	42	25
003---	230/1	253	207	82	16.8	2.1	10	42	35
004---	230/1	253	207	88	19.8	2.1	10	36	45
045---	230/1	253	207	88	23.9	2.1	10	31	55
005---	230/1	253	207	100	27.9	2.1	8	42	60

**FLA** – Full Load Amps      **LRA** – Locked Rotor Amps  
 --- Electrical data shown applicable to all units for which complete model number is not shown  
 \*Permissible limits of the voltage range at which the units will operate satisfactorily

†Copper wire sizes Aluminum field wiring may be used when splice-connected to copper pigtails from unit with factory-supplied wire nuts Use latest National Electrical Code for aluminum wire sizing  
 ‡Maximum dual element fuse size  
 NOTE Control circuit voltage is 24 volts on all units

**START-UP INSTRUCTIONS**

If unit is equipped with crankcase heater, energize heater a minimum of 24 hours before starting unit To energize heater only, set thermostat at “Off” position and close electrical disconnect to condensing unit.

Units with Time Guard® circuit or solid state time-delay may not start for approximately 4 to 5 minutes after thermostat closes. See compressor controls, pages 7 and 8.

**Start Procedure**

1. Backseat (open) liquid and suction line service valves.

**CAUTION:** Do not overtighten service valves. Do not exceed 6 ft-lb torque when tightening.

2. Set thermostat selector switch at “Off.”
  3. Set room thermostat at desired temperature.
  4. Close electrical disconnects energizing entire system.
  5. Set room thermostat at “Cool” and fan switch as desired (“Fan”) (“Auto.”).
- Check system refrigerant charge. See Refrigerant Charging.

Motors and controls will operate satisfactorily in a range from 10% above to 10% below nominal unit voltage (Table 4).

Do not connect charging hoses to capillary-controlled system during initial start procedure. (Loss of charge from this procedure may result in capacity reduction.) If necessary to add manifold gages for servicing, refer to Carrier Standard Service Techniques Manual, Chapter 1, pages 1-5, Fig. 8, for bypass method of returning charge to system. (A charging hose valve must be used to accomplish bypass of refrigerant on all units.)

Table 5 – Service Data

COND UNIT	R-22 CHG* (lb-oz)	CONDENSER FAN		
		Rpm	Diam (in.)	Cfm
38GS014	3- 0	1060	17½	2600
38GS018	3- 0			2600
38GS024	3- 0			2600
38GS030	3- 2			2600
38GS036	3-14			2600
38GS042	4-12			2800
38GS048	5- 3			2800
38GS060	5- 3			2800
38CC030	3- 2	1060	17½	2600
38CC036	3-14			2600
38CC042	3-12			2800
38CC048	5- 3			2800
38CC060	5- 3			2800
38CE002	4- 7	1070/870	17½	2600/2100
38CE003	4-11			2600/2100
38CE004	5- 2			2800/2300
38CE045	5- 6	975/800	17½	2700/2200
38CE005	5-11			2700/2200

\*Factory refrigerant charge adequate for complete system when connected to Carrier approved evaporators that are the same size as condensing unit, with 25 ft of tubing

### COMPRESSOR SERVICE

**Unit Single-Phase Compressors of the Split Capacitor (PSC) Type** require an equalized system pressure to start. When supply voltage is within 10% limit and compressor does not start, give compressor a temporary capacitance boost. See Carrier Standard Service Techniques Manual, Chapter 2, for details. Use a 130-mfd start capacitor. Connect wires with insulated probes to each capacitor terminal. Touch probes to each side of run capacitor or to compressor motor terminals R and S. Start compressor; *pull probes away after 3 seconds. Discharge start capacitor.* Run compressor for 10 minutes, then shut off and allow system pressure to equalize. Try restarting without boost capacitor. If after 2 attempts (without boost capacitor) the compressor does not start, add an accessory start capacitor relay package.

**Unit Single-Phase Compressors That are Equipped With a Compressor Start Thermistor (PTC device):** if compressor will not start, check the thermistor with an ohmmeter as described below. (If evaporator coil does not have a bleed-type expansion device, it may be necessary to remove PTC device and replace with accessory start capacitor and relay.)

### CHECKING START THERMISTOR

1. Shut off all power to unit and wait 5 minutes for thermistor to cool to outdoor temperature.
2. Measure resistance of thermistor with ohmmeter. Normal resistance readings are 50 to 90 ohms at 75 F outdoor temperature.
3. If ohmmeter resistance reading is 0 or much higher than 90 ohms the thermistor is defective and must be replaced.

If start thermistor is good and compressor will not start, disconnect the thermistor from starting circuit and give compressor a temporary capacitance boost as described above. Run compressor for 10 minutes, then shut off and allow system pressure to equalize. Reconnect start thermistor and try restarting compressor without boost capacitor. If after 2 attempts the compressor does not start, remove thermistor and add an accessory start capacitor relay package.

**38CC Units** – Compressor start capacitor and relay or thermistor (PTC) are not required on 3-phase 38CC units.

**Safety Devices** – Refer to Table 6 for particular safety controls that each unit is equipped with.

Table 6 – Compressor Safety Controls

SAFETY CONTROLS	CONDENSING UNITS		
	38GS	38CC	38CE
INTERNAL CURRENT-TEMP SENSITIVE OVERLOAD	014,018 024,030 036,042,048	030,036, 042,048	002,003, 004,045, 005
INTERNAL THERMO (Pilot Duty)	060	060	—
LOW-PRESS. SWITCH	—	030,036, 042,048, 060	Accessory
HIGH-PRESS. SWITCH	—	030,036, 042,048, 060	—
CRANKCASE HEATER	Accessory	030,036, 042,048, 060	Accessory
OUTDOOR FAN THERMOSTAT	—	—	002,003, 004,045,005
TIME GUARD®	—	030,036, 042	—
CPCS	060	048,060	—
SOLID STATE TIMER	—	—	045,005

CPCS – Compressor Protection Control System

### UNIT PROTECTION

**Internal Current And Temperature Sensitive Overloads** reset automatically when internal motor temperature drops to a safe level (overloads may require up to 30 minutes to reset). When an internal overload is suspected of being open, check by using an ohmmeter or continuity tester. If necessary, refer to Carrier Standard Service Techniques Manual, Chapter 2, for complete instructions.

**Low-Pressure Switch** is located on unit suction line and resets automatically. Low-pressure switch settings are: cutout,  $31 \pm 4$  psig; cut-in,  $60 (+ 15, - 0)$  psig.

**High-Pressure Switch** is located on unit liquid line and resets automatically. High pressurestat settings are: cutout,  $425 \pm 5$  psig; cut-in,  $320 \pm 20$  psig.

**Crankcase Heater** warms compressor crankcase. Prevents refrigerant dilution of oil in crankcase.

**Outdoor Fan Thermostat** maintains proper condensing temperature at high outdoor temperatures by switching fan to high speed. Located in control box (on 38CE).

**Filter-Drier** is installed in liquid line.

**Time Guard® Circuit** provides for a 5-minute delay before restarting compressor after shutdown for any reason. On normal start-up the Time Guard timer causes a delay of 15 seconds after thermostat closes before compressor will start. On compressor shutdown, the timer recycles for 4 minutes, 45 seconds. During this time the compressor cannot start.

→ **Solid State Time Delay** provides for a 4-minute delay before restarting compressor after shutdown for any reason. On normal start-up, timer is energized after thermostat closes and causes a 4-minute delay before compressor will start.

**Compressor Protection Control System (CPCS – Solid State)** provides: compressor motor locked rotor protection; compressor start winding protection; compressor motor running overload protection; compressor overtemperature protection; contactor antichatter protection.

The CPCS also provides for a 4- to 6-minute delay before restarting compressor after shutdown for any reason. If compressor loading was light at the moment compressor was shut off, the delay will be approximately 4 minutes. If loading was heavy, the delay will be approximately 6 minutes. To troubleshoot the CPCS, use unit label diagram or wiring booklet and the following Control Circuit Troubleshooting Chart.

#### CONTROL CIRCUIT TROUBLESHOOTING CHART NOTES:

**CAUTION:** Do not operate unit with CPCS receptacle disconnected from board and compressor current transformer connected. This will burn up CPCS board.

1. Ensure thermostat calls for cooling before troubleshooting unit.

2. To disconnect plug from receptacle on CPCS board – press in tabs located on the receptacle and pull plug gently while holding tabs. Do not pull on wiring.
3. When performing troubleshooting checks, CPCS receptacle must be plugged into CPCS board.
4. Receptacle female connections, which do not grip the male pin tightly, may be repaired with a small pen knife.
5. When taking meter readings at CPCS receptacle, bottom meter probe into terminal hole to ensure good electrical contact.
6. Replace CPCS board if electrical short circuit causes compressor failure. An electrical short in compressor can short the triac (electronic switch located on CPCS board). Triac may fail in a closed (conducting) position and will not open the control circuit.

**Compressor Removal** (See Table 7 for compressor information and Fig. 5 for component location.)

1. Shut off power to unit. Vent refrigerant to atmosphere or use refrigerant removal methods shown in Carrier Standard Service Techniques Manual, Chapter 1.
2. Remove top access cover and rear access wrapper (Fig. 5).
3. Remove power leads from compressor terminal box. Unsweat suction and hot gas lines.
4. Remove compressor hold-down bolts. Lift compressor out thru top or back of unit.

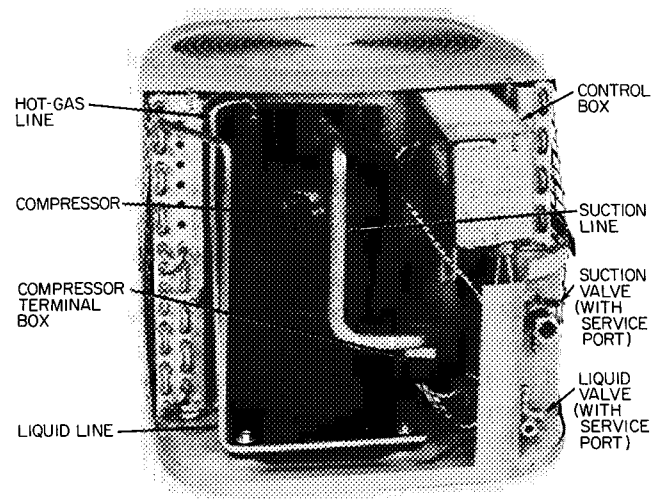

**Fig. 5 – Condensing Unit with Access Panels Removed (38CE Unit Shown)**



# CONTROL CIRCUIT TROUBLESHOOTING CHART (GS,CC048 and 060)

**CAUTION** Compressor current sensing transformer is located on compressor protection control system (CPCS) board. Shut line power off before attempting any service operations (because of presence of high voltage).

Before attempting any corrective action, wait 8 minutes after power is supplied to permit CPCS time delay period to end. If control circuit is broken and unit has no time delay (or if time delay is over 8 minutes), replace CPCS board

## IMPROPER UNIT OPERATION

### STEP 1

Check contactor operation

CONTACTS CLOSE IMMEDIATELY, UNIT DOES NOT RUN

CPCS board and control circuit function. Check compressor, run capacitor, start gear and internal compressor protection

CONTACTS WON'T STAY CLOSED OR OPEN BEFORE ROOM THERMOSTAT IS SATISFIED

Check system pressures and current draw

### CONTACTS NEVER CLOSE

### STEP 2

Check unit voltage at terminals 21 and 23 on contactor

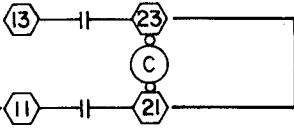

VOLTAGE LOW OR NO VOLTAGE

Obtain correct voltage

### VOLTAGE CORRECT

### STEP 3

Check control circuit and current transformer wiring and connections

LOOSE CONNECTIONS OR IMPROPER WIRING

Repair connection or correct wiring

### WIRING AND CONNECTIONS GOOD

### STEP 4

Check output at 5 va secondary of unit voltage transformer (at terminals 2 and 10 on CPCS receptacle) Should be 23-30 volts

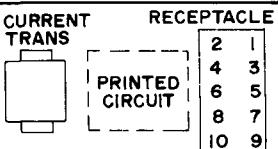

VOLTAGE LOW OR NO VOLTAGE

Replace transformer

### BOARD VOLTAGE CORRECT

### STEP 5\*

Check output at 25 va secondary of unit voltage transformer (at CPCS receptacle terminal 3 and C<sub>2</sub> on contactor) Should be 23-30 volts

VOLTAGE LOW OR NO VOLTAGE

Replace transformer

### VOLTAGE CORRECT

### STEP 6\*

Check contactor voltage at C<sub>1</sub> and C<sub>2</sub> terminals on contactor (C) Should be 23-30 volts

VOLTAGE CORRECT

Replace contactor

### NO VOLTAGE

### STEP 7\*

Check control circuit voltage from contactor (C) terminal C<sub>2</sub> to terminal 1 on control relay. Should be 20-29 volts

VOLTAGE IS LOWER THAN 20 VOLTS†

Check indoor unit power, indoor transformer, thermostat or control relay

### VOLTAGE CORRECT

### STEP 8\*

Check control circuit voltage from contactor (C) terminal C<sub>2</sub> to junction of high-pressure switch (HPS) and low-pressure switch (LPS) Should be 20-29 volts

VOLTAGE IS LOWER THAN 20 VOLTS†

System pressure too high or bad high-pressure switch

### VOLTAGE CORRECT

### STEP 9\*

Check control circuit voltage from contactor (C) terminal C<sub>2</sub> to terminal 8 on CPCS receptacle. Should be 20-29 volts

VOLTAGE IS LOWER THAN 20 VOLTS†

System pressure too low, bad low-pressure switch or open internal protector (IP)

### VOLTAGE CORRECT

### STEP 10

Replace CPCS board

†Voltage reading less than 20 volts may result from feedback circuit

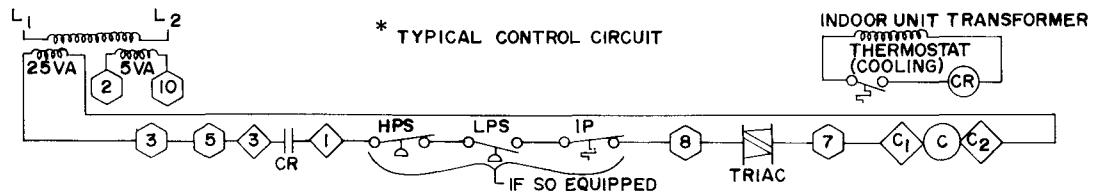

○ CPCS Receptacle

◇ Component Connections

**Table 7 – Compressor Data**

COND UNIT	V/PH	PRODUCTION COMPR*	OIL RECHG (Oz)
38GS014---	208/1	38GS400804	21
38GS014---	230/1	38GS400804	21
38GS018200	208/1	38GC401994	21
38GS018210	208/1	MD2023CB	44
38GS018300	230/1	38GC400224	21
38GS018310	230/1	MD2023CB	44
38GS024200	208/1	38GL400314	42
38GS024210	208/1	MB2723CB	44
38GS024300	230/1	38GL400324	42
38GS024310	230/1	MD2723CB	44
38GS030200	208/1	38GC401984	42
38GS030210	208/1	MB3423CB	44
38GS030300	230/1	38GC401404	42
38GS030310	230/1	MC3423CB	44
38GS036200	208/1	38GC402004	46
38GS036210	208/1	MB4023CB	44
38GS036300	230/1	38GC401564	46
38GS036310	230/1	MC4023CB	44
38GS042---	230/1	38GS400424	46
38GS048---	230/1	PC5329AD	76
38GS060---	230/1	PC6728AB	76
38CC030---	200/230/3	MF3423BC	44
38CC036---	200/230/3	MF4023CB	44
38CC036---	460/3	MH4023CB	44
38CC042---	200/3	38GR403364	46
38CC042---	230/3	38GR403364	46
38CC042---	460/3	38GR403374	46
38CC048---	200/3	PF5326AD	76
38CC048---	230/3	PG5326AD	76
38CC048---	460/3	PH5326AD	76
38CC060---	200/3	PF6725AA	76
38CC060---	230/3	PG6725AA	76
38CC060---	400/3	PH6725AA	76
38CE002---	230/1	MD2023CB	44
38CE003---	230/1	MD3023CB	44
38CE004---	230/1	MC3423CB	44
38CE045---	230/1	PC4629AD	76
38CE005---	230/1	PC5329AD	76

--- Tabular data shown applicable to all models except those shown italicized 000

\*Refer to Service Parts Catalog for replacement compressor model numbers. Single-phase units may include compressor start assist device

**PUMPDOWN PROCEDURE**

The 38GS,CC,CE units may be pumped down in order to make repairs on low side of system without losing complete refrigerant charge.

1. Attach pressure gage to suction service valve gage port.
2. Frontseat the liquid line valve.
3. Jumper low-pressure switch (if unit is so equipped).

4. Start unit and run until suction pressure reaches 5 psig (see Caution).
5. Shut unit off and frontseat suction valve.
6. Vent remaining pressure to atmosphere.

**CAUTION:** Unit condensers will hold only factory supplied amount of refrigerant. Additional refrigerant may cause units to relieve pressure thru internal pressure relief valve (indicated by a sudden rise of suction pressure) before suction pressure reaches 5 psig. If this occurs, shut unit off immediately; frontseat suction valve, and vent remaining pressure to atmosphere.

**REFRIGERANT CHARGING**

The 38GS,CC,CE condensing units contain correct operating charge for complete system when connected to Carrier approved evaporators that are the same size as condensing unit, with 25 ft or less of tubing of recommended size. Charge adjustment may be required on other systems.

Listed (Table 8) and described below are recommended methods of checking, adjusting or recharging Carrier approved systems. When recharging these systems, evacuate system to 5000 microns (29.7-in. vacuum), and weigh in charge shown in Table 5. When system is not evacuated, subtract the following amount from total charge.

- 38GS014,018,024; 38CE002 – .11 lb (1.6 oz)  
 38GS030,036; 38CE003,004; 38CC030,036 – .21 lb (3.2 oz)  
 38GS042,048,060; 38CC042,048,060; 38CE045,005 – .31 lb (4.8 oz)

(Dial-a-charge charging cylinder is an accurate device used to recharge systems by weight. These cylinders are available at refrigeration supply firms.) After weighing in charge, check or adjust charge using the Chargemaster® charging device, charging chart or sight glass method as recommended in Table 8. Refer to Carrier Standard Service Techniques Manual, Chapter 1, for system evacuation – dehydration instructions.

When 38GS,CC,CE condensing units are connected to other than a Carrier evaporator, evacuate system and weigh in charge shown in Table 5 or use sight glass method of recharging (38CC thermal expansion valve systems only).

**CAUTION:** Do not overcharge 38GS,CC,CE systems. An overcharge may result in compressor damage due to refrigerant flooding.

**Table 8 — Refrigerant Charging Methods  
(Carrier Approved Systems)**

COND UNIT	METHODS OF CHECKING OR ADJUSTING CHARGE			RECHARGING METHODS		
	System Refrigerant Control			System Refrigerant Control		
	AccuRater™	Capillary Tube	TXV	AccuRater	Capillary Tube	TXV
38GS	Chargemaster® or Charging Chart		Charging Chart	Weight Method plus Chargemaster or Charging Chart		Weight Method plus Charging Chart
38CC	Chargemaster or Charging Chart		Charging Chart or Sight Glass	Weight Method plus Chargemaster or Charging Chart		Weight Method plus Charging Chart or Sight Glass
38CE	Chargemaster or Charging Chart		Charging Chart	Weight Method plus Chargemaster or Charging Chart		Weight Method plus Charging Chart

TXV — Thermal Expansion Valve

**Charging Chart Method** — For thermal expansion valve systems, use Charging Chart, Fig. 6 or 7. See Carrier Standard Service Techniques Manual, Chapter 1, for procedure. For capillary tube or AccuRater™ systems, use Charging Chart, Fig. 8 or 9 and the following procedure:

1. Operate unit a minimum of 10 minutes before checking charge.
2. Measure suction pressure by attaching a gage to suction valve service port.
3. Measure suction line temperature by attaching a service thermometer to unit suction line near compressor. (Insulate thermometer for accurate readings.)
4. Measure outdoor (condenser inlet) air dry-bulb temperature with second thermometer.
5. Refer to Charging Chart (Fig. 8 or 9). Find condenser air temperature and project horizontally to curve showing suction pressure.
6. From intersect point, project vertically downward to chart suction line temperature.
7. If unit has a higher suction line temperature than chart, add refrigerant until chart temperature is reached.
8. If unit has a lower suction line temperature than chart, bleed refrigerant until chart temperature is reached.
9. If condenser inlet air temperature or unit suction pressure changes, change to new suction line temperature on chart.

**Chargemaster® Operation** — Operate unit 10 minutes before using Chargemaster (Carrier Part No. 38GC680004).

1. Tape Chargemaster feeler bulb to suction line close to condensing unit. Insulate bulb. Ensure suction line is clean for good contact with bulb.
2. Connect refrigerant drum to Chargemaster inlet port with drum in position for vapor charging.
3. Connect Chargemaster outlet port to unit suction valve service port.
4. Crack valves on refrigerant drum and Chargemaster to purge lines from drum to suction valve. After purging lines, close valve on Chargemaster only.
5. Measure outdoor air dry-bulb temperature.
6. Crack unit suction valve and read *evaporator temperature at red needle position* on Chargemaster temperature gage and *suction line temperature at black needle position*.

**CAUTION:** Do not read evaporator temperature with Chargemaster valve open.

7. Enter Chargemaster Charging Chart, Table 9 or 10, at outdoor air temperature (step 5) and evaporator temperature (step 6). Find the suction line temperature required for correct system charge. If actual suction line temperature (step 6) is higher than table value, the system is undercharged. If suction line temperature is lower than table value, the system is overcharged.

Example (Table 10): At outdoor air temperature of 85 F and evaporator temperature of 44 F, the system will be correctly charged at 71 F ± 2 F suction line temperature.

8. Add charge by slowly opening Chargemaster® valve. If necessary, reduce charge by bleeding at liquid line service valve. Check outdoor air and evaporator temperature during procedure. If they change, refer back to Chargemaster Charging Chart for new value.

Correct use of Chargemaster ensures an optimum refrigerant charge will be in system when conditions and system components are normal. However, the Chargemaster does not solve or fix system abnormalities. It indicates correct charge for condition of system. It will not make corrections for dirty filters, slow fans, excessively long or short suction lines or other abnormal conditions.

This charging device ensures that a correct relationship exists between outdoor temperature, evaporator temperature, and suction line temperature on a specific system.

**Sight Glass Method** — A satisfactory operating charge can be obtained on thermal expansion valve systems by charging to a clear sight glass. For optimum charge, elevate high-side pressure to  $380 \pm 10$  psig by blocking condenser fan discharge or condenser entering air. Charge to a clear sight glass while holding high-side pressure constant. For peak efficiency, adjust charge to yield a liquid refrigerant temperature at the evaporator that is approximately the same as outdoor dry-bulb temperature.

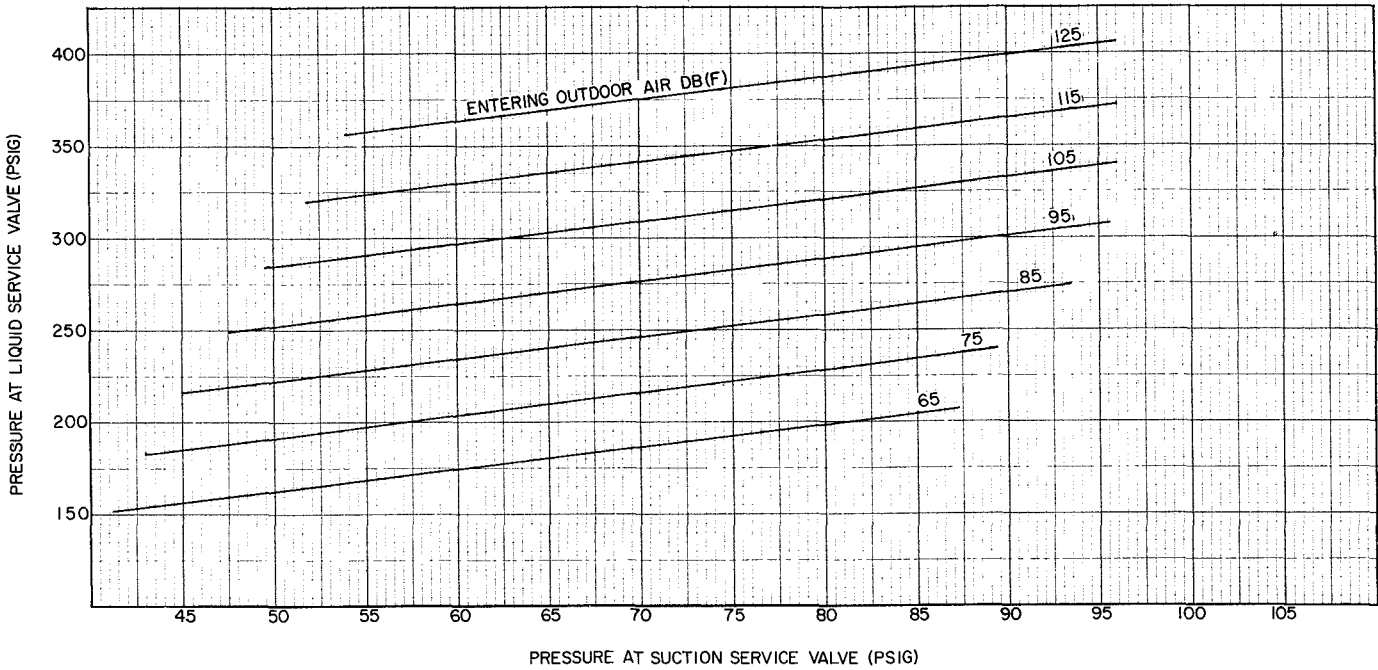

Fig. 6 — 38GS,CC Charging Chart (TXV Systems)

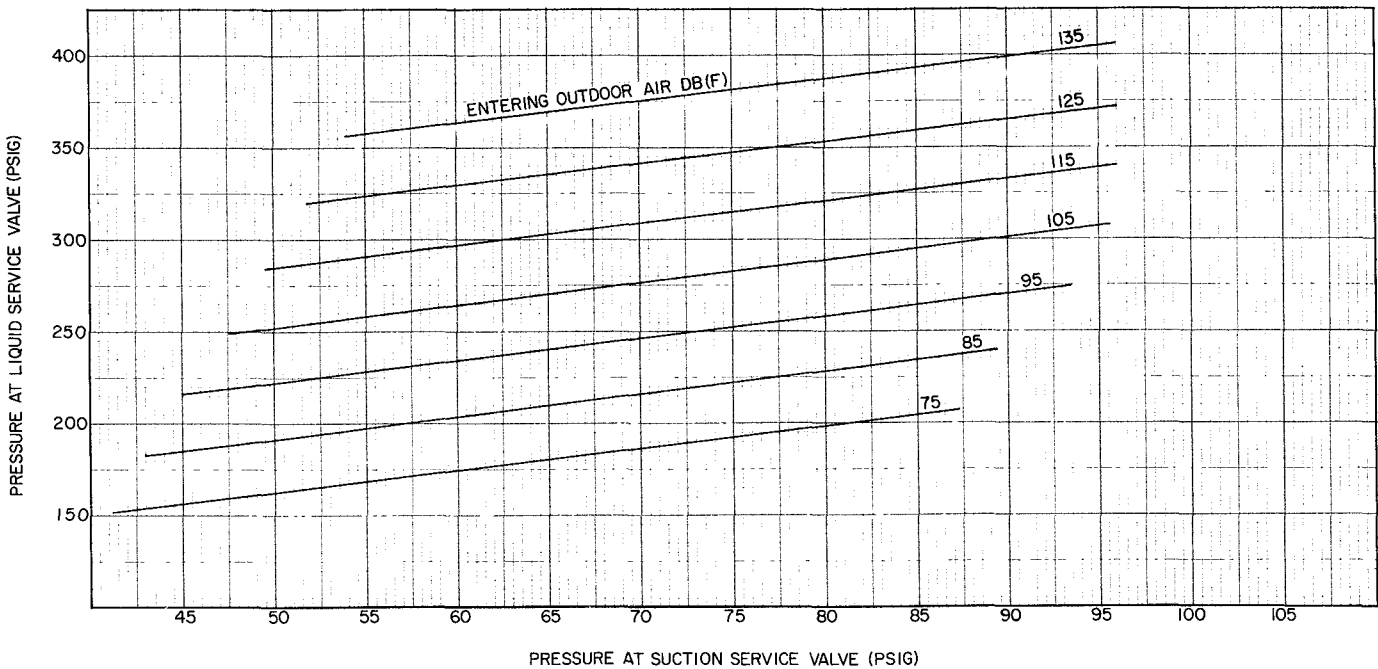
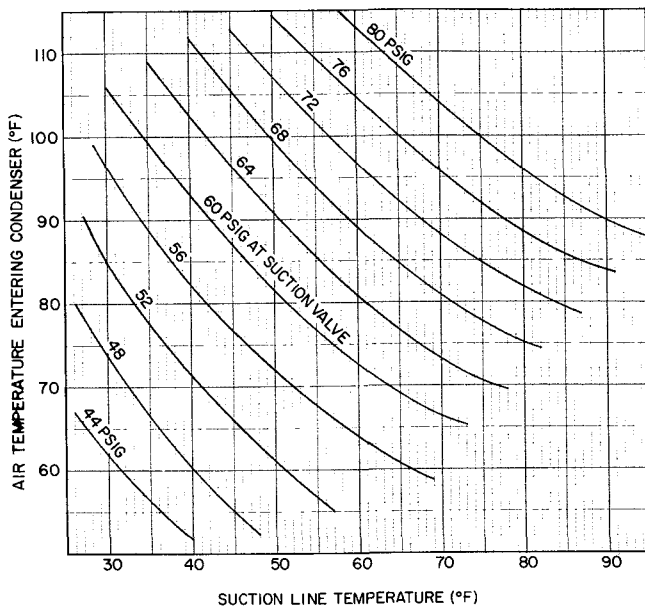
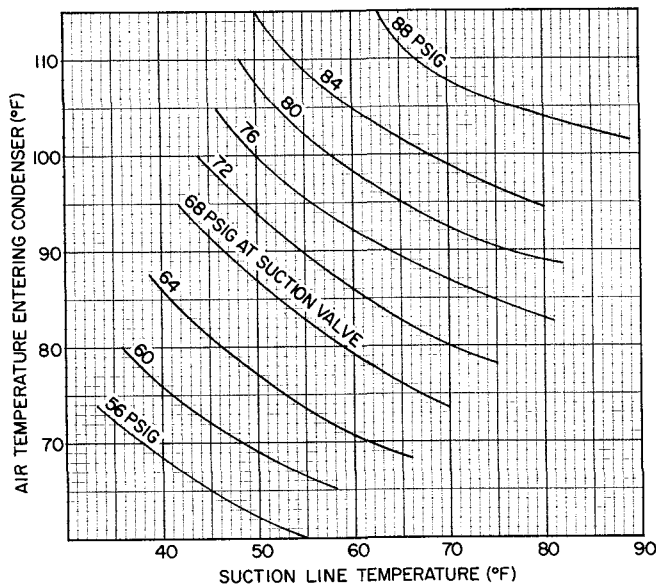

Fig. 7 — 38CE Charging Chart (TXV Systems)

**Table 9 – 38GS,CC Chagemaster® Charging Chart (Capillary Tube or AccuRater™ Systems)**



**Fig. 8 – 38GS,CC Charging Chart (Capillary Tube or AccuRater™ Systems)**



**Fig. 9 – 38CE Charging Chart (Capillary Tube or AccuRater™ Systems)**

OUTDOOR TEMP (F)	EVAPORATOR TEMP (F)*									
	21	25	28	31	34	37	40	43	45	48
	Suction Line Temperatures									
60	32	40	51							
62	30	38	49							
64	28	37	47	60						
66	27	35	45	57						
68		34	43	54	67					
70		32	41	52	64					
72		31	39	50	61	72				
74		30	37	48	58	69				
76		29	36	46	56	66				
78		27	35	44	54	63	75			
80		26	33	42	52	61	72			
82			32	40	50	59	68	80		
84			31	38	48	57	66	76		
86			29	37	46	55	63	73	85	
88				35	44	53	61	70	81	
90				34	42	51	59	68	78	90
92				33	41	49	57	65	75	86
94					39	47	55	63	72	83
96					38	45	53	61	70	80
98					36	44	51	59	67	77
100						42	49	57	65	75
102						41	48	55	63	73
104						39	46	53	61	70
106							45	51	59	68
108							43	49	57	65
110							41	47	55	63
112								46	53	61
114									50	59

\*Saturated evaporator temperature which is the equivalent temperature of pressure taken at the condensing unit suction service valve

**Table 10 – 38CE Chagemaster® Charging Chart (Capillary Tube or AccuRater™ Systems)**

OUTDOOR TEMP (F)	EVAPORATOR TEMP (F)											
	32	34	36	38	40	42	44	46	48	50	52	54
	Suction Line Temperature (F)											
60	60											
65	49	58	65									
70	41	48	58	68	70							
75	35	41	48	58	68	75						
80	31	36	42	50	59	69	80					
85			38	44	52	60	71	82				
90				40	47	53	61	69	78			
95					42	48	53	59	67	79		
100						43	47	52	58	68	88	
105							44	48	53	60	75	104
110									49	54	65	80
115										50	62	69

Example

## COMPATIBLE FITTING REPAIR

**Leaking Mechanical Connection** — Frontseat condensing unit service valves and relieve refrigerant pressure in tubing. Back locknut off Compatible Fitting onto tube. Cut fitting between threads and seal ring head as shown in Fig. 10. Remove tubing section remaining in threaded portion of fitting. Discard locknut.

Clean, flux, and insert new tube end into remaining portion of Compatible Fitting. *Wrap valve base in wet rag.* Heat and apply low temperature (450 F) solder.

**Leaking Sweat Connection** — Frontseat service valves and relieve refrigerant pressure in tubing. Clean and flux area around leak and apply low temperature (450 F) solder.

Evacuate or purge evaporator coil and tubing system. Add refrigerant charge (see charging instructions).

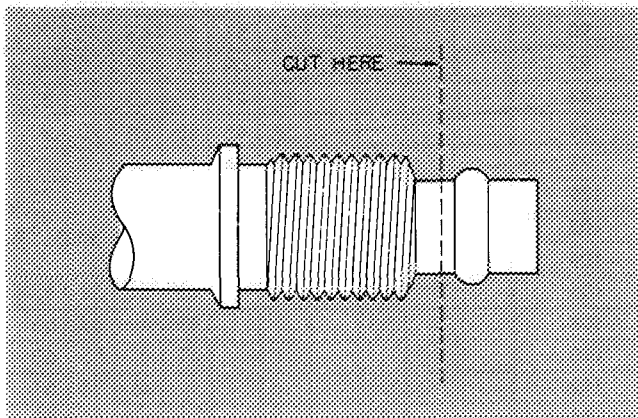

Fig. 10 — Repair of Mechanical Connection

## CONDENSER

**Coil Cleaning** — *Ensure power to unit is shut off*  
Clean the condensing unit coil at the beginning of every cooling season or more often if required. Use ordinary garden hose at a pressure high enough to clean efficiently. For best results, unscrew and remove unit top cover (grille). Insert hose nozzle between fan blades and spray coil fins from inside-to-outside the unit. If unit has a double-row coil, loosen screws to separate coils, and flush dirt toward outside of both coils. Flush dirt from base pan by spraying water thru top of unit. Avoid splashing mud on coil or water on the fan motor.

**Metal Fan** — Required fan position is shown in Fig. 11. Adjust fan by loosening setscrew and moving fan blades up or down.

**Plastic Fan** is correctly positioned in unit by placing fan on motor shaft — align flat mark on top of fan hub with flat on shaft. Press down evenly on top of fan hub until shaft bottoms in fan hub.

## Fan Motor Removal

1. Shut off power to unit.
2. Remove unit top access cover and fan grille.
3. Disconnect fan motor wires from fan capacitor and control relay or contactor. Pull wires out of control box.
4. Remove fan from motor shaft by pulling upward on fan hub.
5. Loosen bolt holding fan motor to motor mounting bracket. Remove motor thru top of unit. To replace motor, place motor on self-positioning motor mounting flanges and re-tighten bolt.

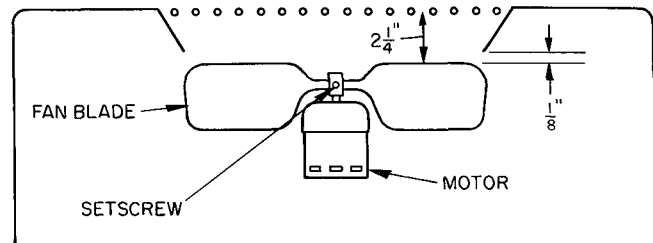

Fig. 11 — Condenser Fan Position

## LUBRICATION

**Fan Motor Bearings** — Oiling holes are provided at each end of current condenser fan motor. Remove fan motor and lubricate motor with 32 drops (16 drops per hole) of SAE-10 nondetergent oil at intervals described below:

- a. Annually, when environment is very dirty, ambient temperature is higher than 105 F and average unit operating time exceeds 15 hours a day.
- b. Every 3 years when environment is reasonably clean, ambient temperature is less than 105 F and unit operating time averages 8 to 15 hours a day.
- c. Every 5 years when environment is clean, ambient temperature is less than 105 F and unit operating time averages less than 8 hours a day.

**Compressor** contains factory oil charge. When oil is lost, see Table 7 for oil charge and Carrier Standard Service Techniques Manual, Chapter 1, page 1-21, for instructions. Use Carrier PP33-1, Texaco Capella B or Suniso 3G oil.

# TROUBLESHOOTING CHART\*

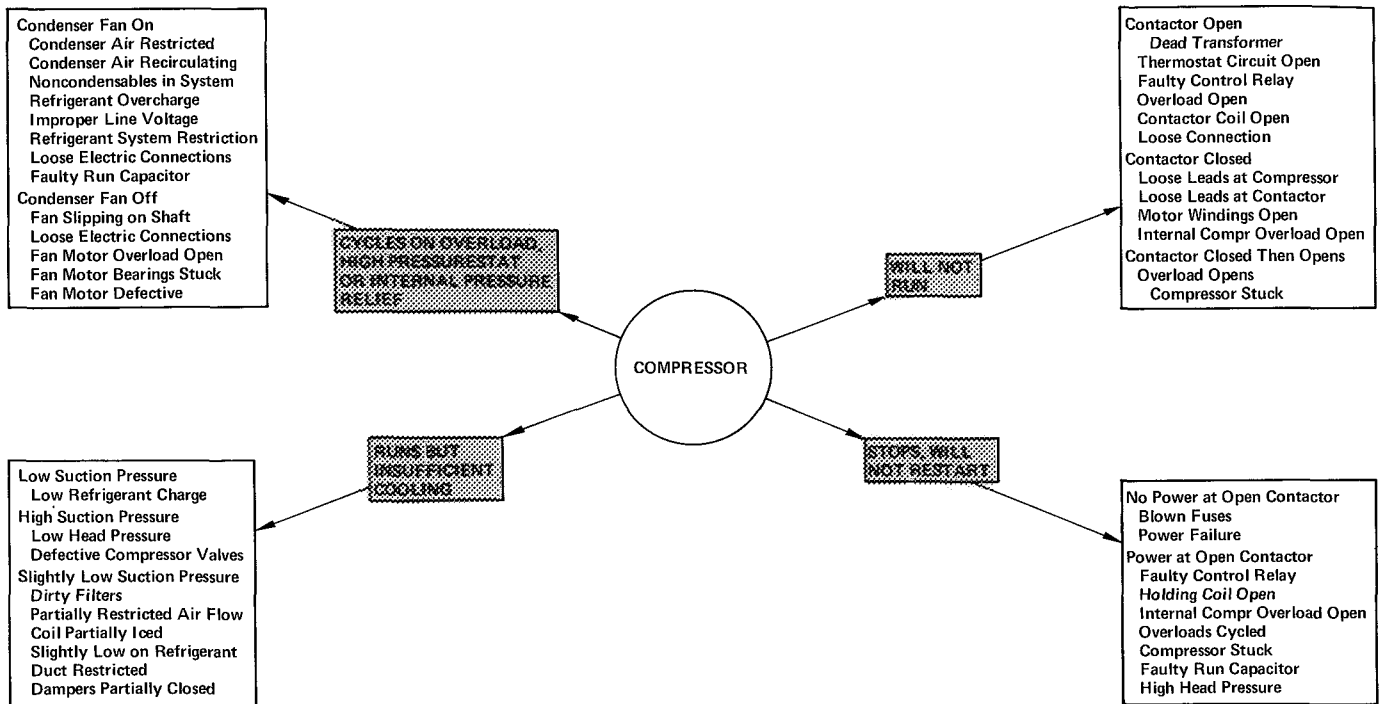

\*To troubleshoot control circuit on 38GS048,060 and 38CC048,060 units, see Control Circuit Troubleshooting Chart, page 9.

For replacement items use Carrier Specified Parts.

Manufacturer reserves the right to discontinue, or change at any time, specifications or designs without notice and without incurring obligations.

**Tab 4**

Form 38GS-13SI Supersedes 38GS-10SI

Printed in U.S.A.

2-75

Codes D and MS

Catalog No. 533-810

Download from [www.Somanuals.com](http://www.Somanuals.com). All Manuals Search And Download.



## Free Manuals Download Website

<http://myh66.com>

<http://usermanuals.us>

<http://www.somanuals.com>

<http://www.4manuals.cc>

<http://www.manual-lib.com>

<http://www.404manual.com>

<http://www.luxmanual.com>

<http://aubethermostatmanual.com>

Golf course search by state

<http://golfingnear.com>

Email search by domain

<http://emailbydomain.com>

Auto manuals search

<http://auto.somanuals.com>

TV manuals search

<http://tv.somanuals.com>