

Single-Package Water-Source Heat Pumps

INDEX

	Page		Page
SAFETY CONSIDERATIONS	1	● MAKE CONDENSATE DRAIN LINE CONNECTION	
INSTALLATION	1-5	Step 4 — Make Electrical Connections ...	4
Step 1 — Check Equipment and Jobsite	1	● INSTALL A BRANCH CIRCUIT DISCONNECT PER NEC	
● UNPACKAGE UNIT		● BRING POWER LEADS INTO UNIT	
● INSPECT EQUIPMENT		● CONNECT GROUND LEAD TO GROUND LUG IN SPLICE BOX	
● COMPLETE OR CONSIDER THESE SYSTEM REQUIREMENTS		● SET FAN MOTOR SPEED	
Step 2 — Connect Supply Ductwork	2	● CONNECT CONTROL POWER WIRING	
Step 3 — Make Piping Connections	3	START-UP	6
● CONNECT WATER SUPPLY AND RETURN LINES		SERVICE	7
● INSTALL BALANCING VALVES			

SAFETY CONSIDERATIONS

Installation and servicing of air conditioning equipment can be hazardous due to system pressure and electrical components. Only trained and qualified service personnel should install, repair or service air conditioning equipment.

Untrained personnel can perform basic maintenance functions of cleaning coils and cleaning and replacing filters. All other operations should be performed by trained service personnel. When working on air conditioning equipment, observe precautions in the literature, tags and labels attached to the unit and other safety precautions that may apply.

Follow all safety codes. Wear safety glasses and work gloves. Use quenching cloth for brazing operations. Have fire extinguishers available for all brazing operations.

WARNING: Before performing service or maintenance operations on system, turn off main power switch to indoor unit and outdoor unit. Turn off accessory heater power switch if applicable. Electrical shock could cause personal injury.

INSTALLATION

Step 1 — Check Equipment and Jobsite

UNPACKAGE UNIT — Move to final location. Slide from carton taking special care not to damage service valves or grilles.

INSPECT EQUIPMENT — File claim with shipping company if shipment is damaged or incomplete.

COMPLETE OR CONSIDER THESE SYSTEM REQUIREMENTS before installation:

- a. Consult local building codes and National Electrical Code (NEC) for special installation requirements.
- b. Consider type of water source. Ensure there is an adequate supply of water at temperature of 60 F to 90 F with minimum pressure of 10 psig.
- c. Provide sufficient space for water piping, condensate drain, wiring and servicing unit. See Fig. 1. When front (external) water piping connections are used, locate unit so piping does not block front access panels. (Units installed in confined areas may have to be removed for major servicing such as compressor or fan motor replacement.)
- d. Provide a minimum 6-in. clearance between return air filter and adjacent wall.
- e. Mount unit on floor or solid platform so unit is elevated. (The 50HQ units can be suspended from ceiling. See "f" below.) Make sure unit is supported from the bottom. To reduce sound transmission, especially when unit is located in a closet or utility room having louvered doors, the following acoustical treatment is recommended: place an isolation pad under unit. Pad must be same size as unit base. Construct a 1-in. fiberglass sound shield in front of unit.

f. 50HQ units include a suspension package for ceiling installation. To attach hanging brackets, install 4 bolts (5/16 - 18-3/8 in. lg) thru bracket into the 4 weld nuts located on bottom of unit. Insert the threaded rod thru rubber grommet located in hanging bracket and attach with flat washer and double nut. See Fig. 3.

Step 2 — Connect Supply Ductwork — Supply air duct flange is shipped inside unit. Remove flange from shipping location and install on unit supply air opening. Connect supply air ductwork to unit supply air duct connection flange. Refer to Fig. 1 and 2 and Table 1 and 2 for connection size and location. If necessary, refer to Carrier System Design Manual, Part 2, for system air duct design.

When designing and installing ductwork, consider the following:

- Size duct for 350 to 450 cfm per ton of cooling capacity.
- Avoid abrupt duct size increases and reductions.
- Use flexible connectors between ductwork and unit to prevent transmission of vibration.
- Ducts passing thru an unconditioned space must be insulated and covered with vapor barrier in accordance with the latest issue of SMACNA (Sheet Metal and Air Conditioning Contractor's National Association) and NESCA (National Environmental Systems Contractor's Association) minimum installation standards for residential heating and air conditioning systems.

Table 1 — Installation Data — 50VQ (See Fig. 1.)

MODEL 50VQ	014	018	022	027	033	042	048	060	080	
OPER WT (lb)	220	240	260	270	290	320	—	—	—	
DIMENSIONS (ft.-in.)	1-10-1/8 (Includes Filter Section)								2- 0	
	1-9-1/8								1-10	
	A									4- 0
	B									—
	C									—
D	3- 2-5/16	3- 2-5/16	3- 2-5/16	3- 2-5/16	3- 2-5/16	3- 2-5/16	—	—	—	
E	0- 1-1/2	0- 1-1/2	0- 1-1/2	0- 1-1/2	0- 1-1/2	0- 1-1/2	—	—	—	
F	0- 1-5/8	0- 1-5/8	0- 7-5/8	0- 7-5/8	0- 7-5/8	0- 5-7/8	—	—	—	
SUPPLY DUCT CONN. (ft.-in.)	G	0-11-1/4	0-11-1/4	0-11-1/4	0-11-1/4	0-11-1/4	0-10-1/4	—	—	
	H	0-10-1/4	0-10-1/4	0-11-7/8	0-11-7/8	0-11-7/8	1- 1-5/8	1-0-7/16	1-1-1/16	
FILTER (1) Size (in.)	Disposable, 1-in thick								—	
	I	16 x 20	16 x 20	16 x 20	20 x 20	20 x 20	20 x 20	—	—	

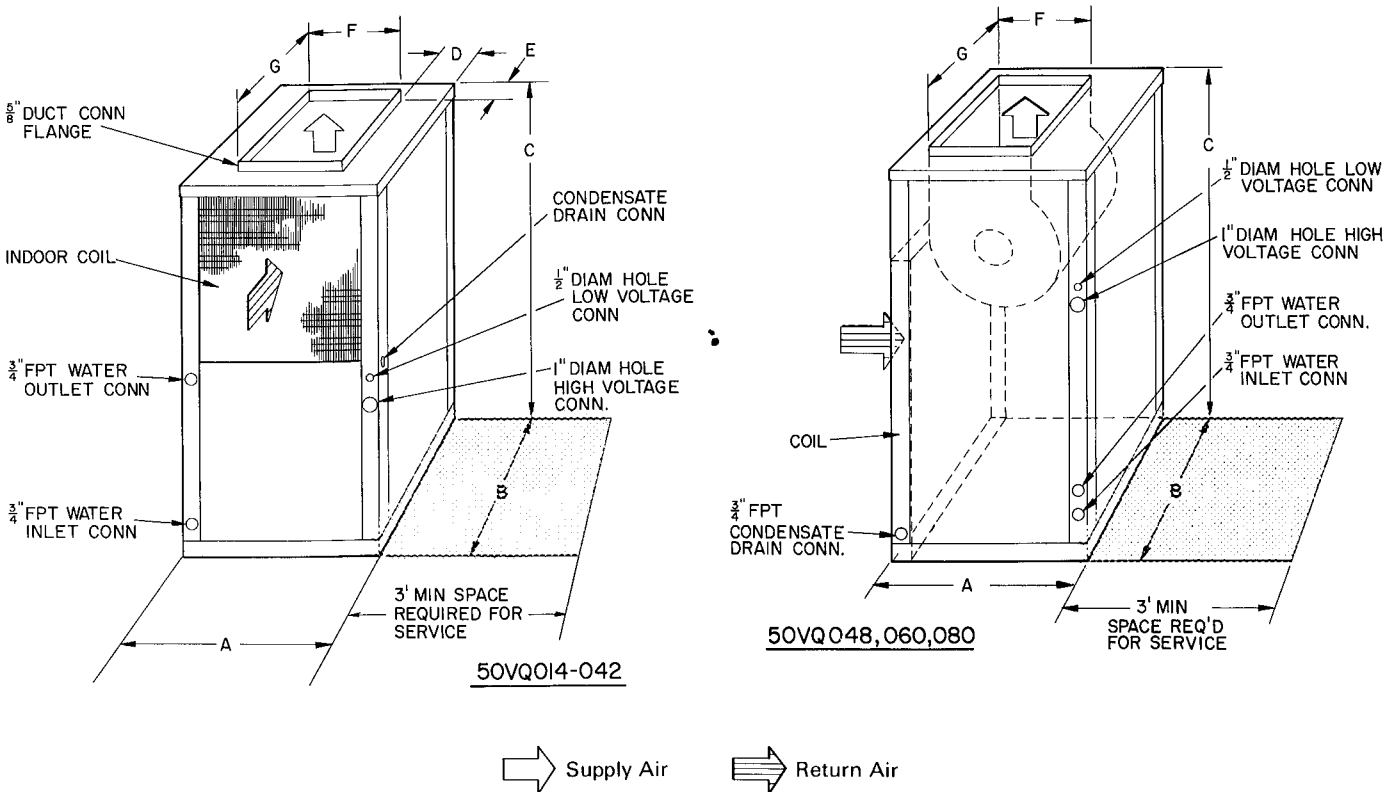

Fig. 1 — Dimensions and Connections — 50VQ

Table 2 — Installation Data — 50HQ (See Fig. 2.)

MODEL 50HQ	014	018	022	027	033	042	048	060	080	
OPER WT (lb)	185	195	210	220	230	250	300	325	360	
DIMENSIONS (ft-in.)										
A	3-10-3/8						4-0			
B	1-10-3/16*						1-11*			
C	1-6						2-0-7/16			
D	0- 3-7/16						0-3-7/16			
E	0- 2-3/8						0-2-3/8			
SUPPLY DUCT CONN (ft-in.)										
F	1- 1-3/8						1-0-7/16		1-7-7/8	
G	0- 9-7/16								0-11-15/16	
ACCESSORY FILTER (1) Size (in.)	17 x 22-3/4						Replaceable Media		—	

*Includes 1-in accessory filter

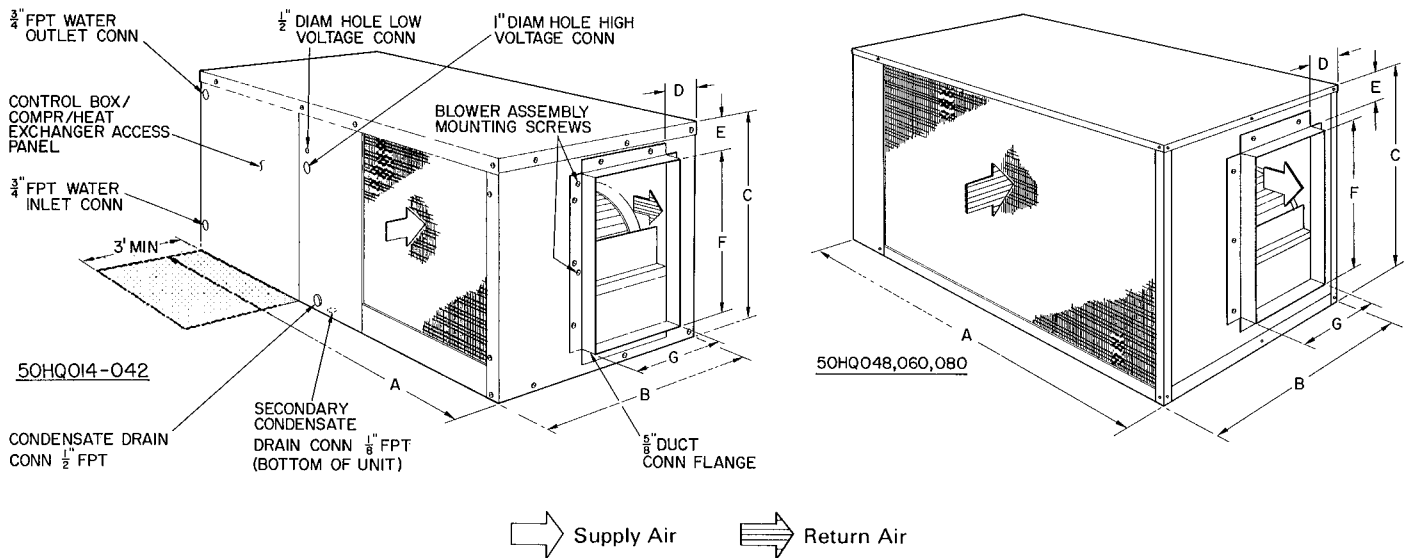

Fig. 2 — Dimensions and Connections — 50HQ

Step 3 — Make Piping Connections

CONNECT WATER SUPPLY AND RETURN LINES to water inlet and outlet pipe connections shown in Fig. 4 and 5. Place plug in unused connections. Use flexible hose for water line to reduce possible vibration and improve unit serviceability. Make sure hoses or pipes are suitable for system water pressure and sized for proper flow rate.

CAUTION: Improper heat exchanger water flow due to piping, valving or improper pump operation is hazardous to units.

For water flow and temperature data refer to START-UP section, page 6.

CAUTION: Galvanized pipe or fittings are not recommended for use with these units due to possible electrolysis.

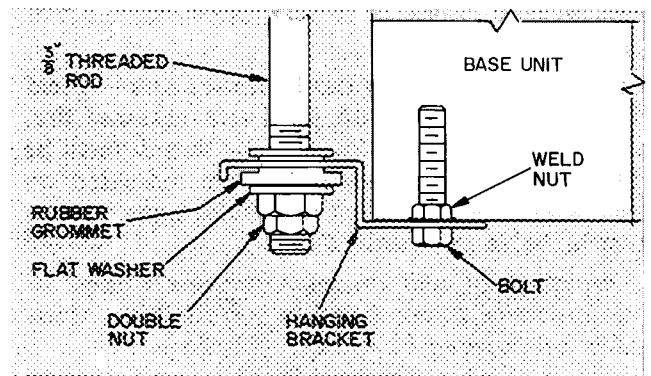

Fig. 3 — Suspension Kit Installation — 50HQ

Table 3 — Electrical Data

UNIT MODEL 50HQ.VQ	V/PH/HZ	OPERATING VOLTAGE		COMPRESSOR		FAN FLA	MINIMUM CIRCUIT AMPS	MAXIMUM FUZE AMPS
		Max	Min	LRA	RLA			
014	208-230/1/60	253	197	37.5	9.6	7	12.7	15
018				53.0	13.4	9	17.7	25
022				65.0	13.3	1.5	18.1	25
027				66.0	16.2	1.7	22.0	35
033				88.0	23.2	2.5	31.6	50
042				100.0	27.7	3.2	37.8	50
048				94.0	23.9	3.4	33.3	50
060				130.0	25.9	4.5	36.9	50
033	208-230/3/60	253	187	87.0	13.8	2.5	19.8	25
042				100.0	18.5	3.2	26.3	35
048				80.0	13.3	3.9	20.5	40
060				98.0	20.9	4.5	30.6	45
080				137.0	20.6	6.2	32.0	45
033	460/3/60	506	414	30.0	6.0	1.4	8.9	15
042				36.5	6.9	1.6	10.2	15
048				35.0	8.2	2.0	12.3	15
060				49.0	10.4	2.3	15.3	25
080				69.0	11.4	3.1	17.4	25

FLA — Full Load Amps
 LRA — Locked Rotor Amps
 RLA — Rated Load Amps

INSTALL BALANCING VALVES (with shutoff) in water supply and return lines for water flow adjustment and a means of water shutoff, if necessary, when servicing unit. When multiple units are connected in parallel, valves permit removal of one unit without interrupting water flow to other units.

MAKE CONDENSATE DRAIN LINE CONNECTION to female pipe connection provided on unit, Fig. 4 and 5. Install a trap in condensate line as close as possible to unit. Trap must be at least 3 in. deep and not higher than the bottom of unit condensate drain opening. Pitch condensate line to open drain or sump. Insulate a condensate drain line located above a living area.

50HQ Units Only — If a secondary drain is required, remove plastic cap from secondary drain connection located in bottom of unit and connect drain so that discharge is obvious to maintenance personnel.

Step 4 — Make Electrical Connections — Field wiring must comply with local and national fire, safety and electrical codes. Voltage to unit must be within the operating voltage range indicated on nameplate or in Table 3. On 3-phase units, phases must be balanced within 2%.

Operation of unit on improper line voltage or with excessive phase imbalance constitutes abuse and is not covered by Carrier Warranty.

INSTALL A BRANCH CIRCUIT DISCONNECT PER NEC of adequate size to handle unit starting current. Locate disconnect within sight of and readily accessible from the unit, per Section 440-14 of National Electrical Code (NEC).

BRING POWER LEADS INTO UNIT — Extend leads from disconnect per NEC thru hole provided (Fig. 1 and 2) into line wiring splice box, Fig. 6.

CONNECT GROUND LEAD TO GROUND LUG IN SPLICE BOX for safety. Connect power wiring. See Fig. 6. Splice line power leads to yellow and black pigtails on single-phase units or yellow pigtails on 3-phase units. Use wire nuts. Tape each connection.

Unit transformer on 208-230-volt units is factory wired for 230/24-volt operation. For 208/24-volt operation, remove black (230-v) transformer lead from unit contactor and connect red (208-v) lead to contactor. Cap unused transformer lead.

SET FAN MOTOR SPEED — Set fan motor for high-, medium- or low-speed operation as follows:

1. Remove unit fan section access panel.
2. Locate Molex fan speed selector block on fan housing, Fig. 7. Selector block receptacle 1 is high fan speed, receptacle 2 is medium fan speed and receptacle 3 is low fan speed. Yellow and black fan motor power leads from control box are connected to selector block receptacle C and 1. Yellow lead is common, black lead is speed-change lead.
3. To change fan motor speed remove black lead from selector block receptacle and plug it into desired receptacle. Receptacle 4 is not used.

CAUTION: For proper unit operation, set unit fan motor speed for air quantity within range shown in Table 4.

Set Fan Motor Speed on 460-Volt Units — Two-speed fan motor is factory wired for high-speed operation. (Yellow and black power leads from control box are connected to the yellow and black fan motor leads.) Change fan motor to low speed by wiring as follows:

1. Splice the violet and black fan motor leads together.

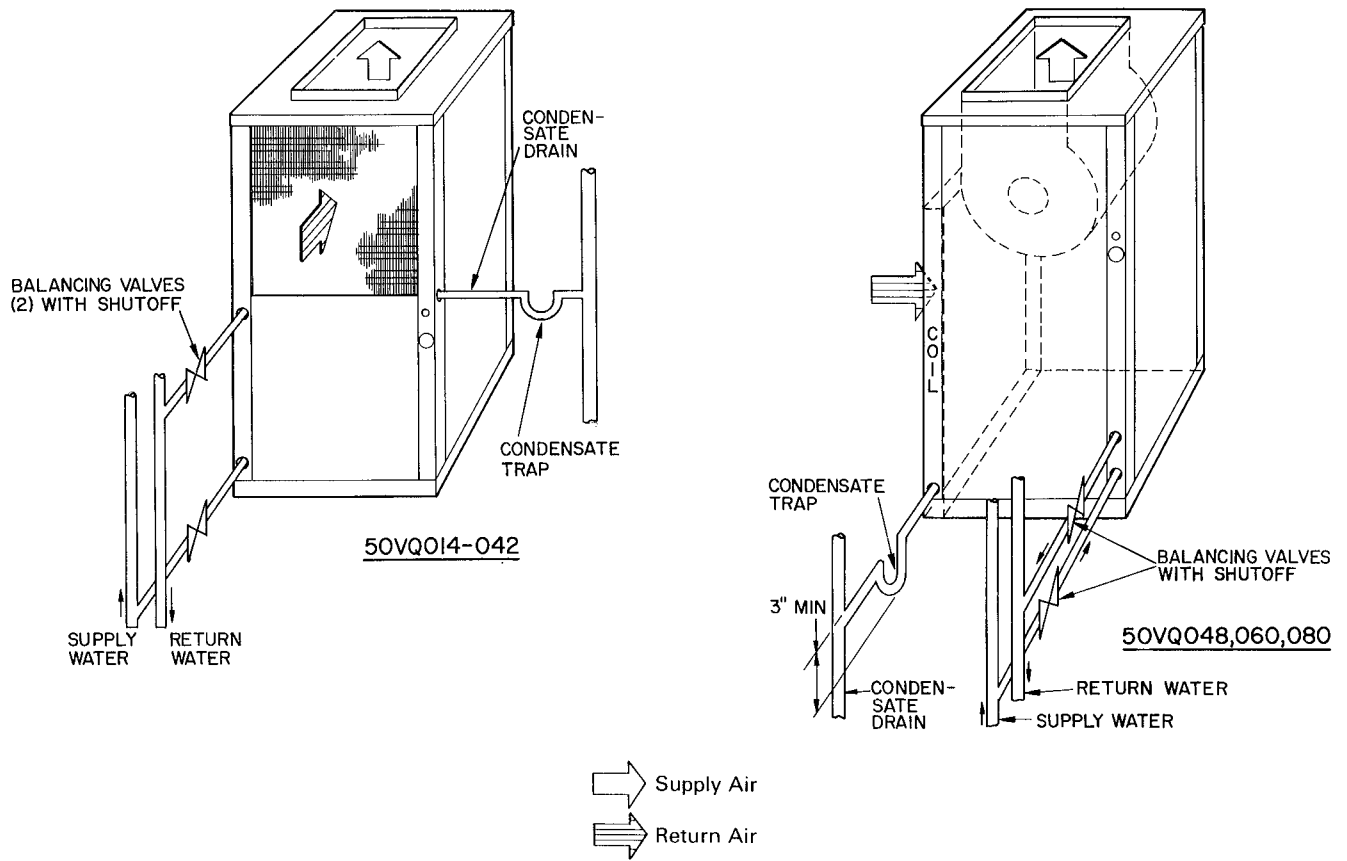

Fig. 4 — Water Piping — 50VQ

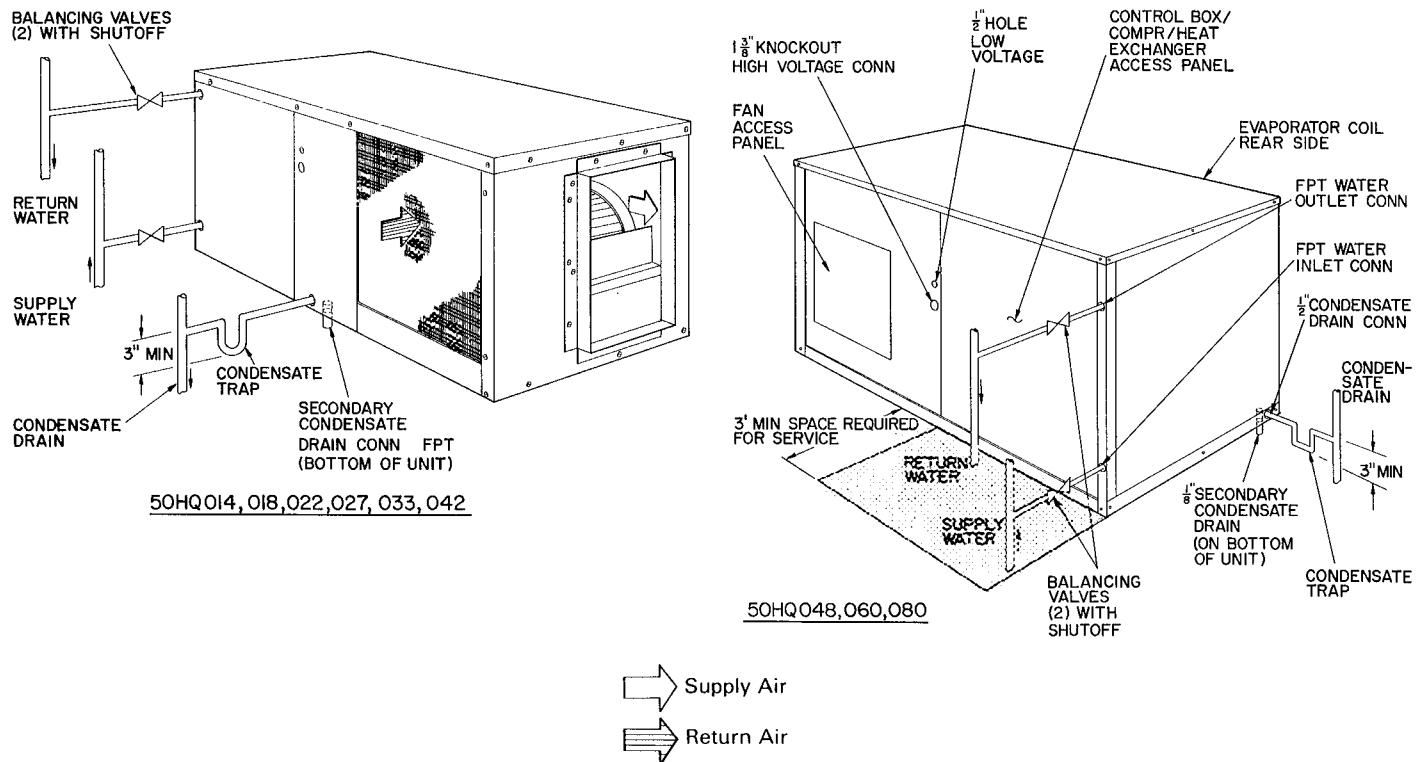

Fig. 5 — Water Piping — 50HQ

- Splice yellow and black power leads from control box to yellow and red motor leads. (Yellow-to-yellow and black-to-red.)

CONNECT CONTROL POWER WIRING (24-v)

Power leads are brought thru 1/2-in. hole provided in unit, Fig. 1 and 2. Extend leads to control wiring terminal board located on top of control box, Fig. 7. Connect leads to terminal board as shown in Fig. 6.

Use Carrier-specified room thermostat and sub-base for proper unit operation. Be sure that field-installed jumper wire is connected between subbase terminals W and Y. Set thermostat heat anticipator at 0.45 amp for 1-phase units and 0.50 amp for 3-phase units.

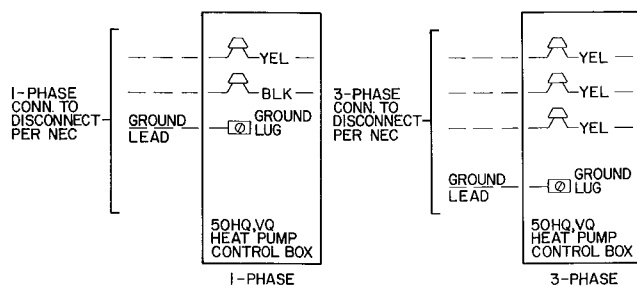

Fig. 6 — Line Power Connections

START-UP

Water Flow and Temperature Data

- Consider design water flow rates for efficient operation. See Table 4 for permissible water flow range.
- Ensure that water temperature entering unit is between 60 F minimum and 90 F maximum. If water temperature below 60 F must be used, insulate supply line and install a secondary drain pan under the unit to remove condensate from heat exchanger and internal plumbing.

CAUTION: Water temperature outside specified temperature range may cause damage to unit. Do not jumper low temperature switch in order to use ethylene glycol.

- Ensure that supply water is clean and air is purged from system. Air in supply water causes scaling in heat exchanger. Foreign material in water and/or excessive velocity of water can cause damage to tubing.

To Start Unit — Ensure that air filter is in place on unit filter flanges provided. Do not operate unit without filter in place. Adjust the thermostat as follows:

- Set selector switch at OFF.
- Turn on main disconnect switch to unit.

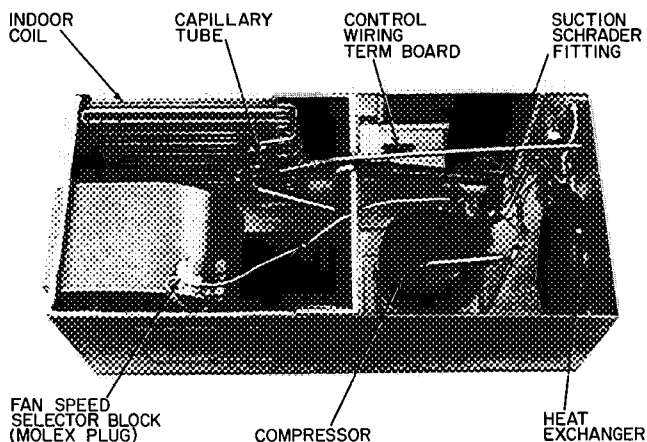

Fig. 7 — Typical Component Arrangement (50HQ014-042 Shown)

- Set fan switch as desired (ON or AUTO.).
- Set thermostat dial at desired temperature.
- Set selector switch at HEAT or COOL.

Check system refrigerant charge. See SERVICE, Refrigerant Charging on page 8.

Unit Single-Phase Compressors that are equipped with a compressor start thermistor (PTC device) — When supply voltage is within limits indicated on nameplate and compressor will not start, check the thermistor with an ohmmeter.

If the PTC is good, and the compressor does not start, disconnect the PTC from the starting circuit and give unit a temporary capacitance boost. Refer to Carrier Standard Service Techniques Manual, Chapter 2, for details on capacitance boost procedure. If unit does not start with capacitance boost, compressor may be defective. If unit does not start, check starting capability with PTC assistance. If questionable, remove PTC, add start capacitor and start relay per start kit installation instructions.

WARNING: Capacitance boost or installation of start capacitor and start relay should be performed by trained personnel. Improper procedure could cause personal injury or equipment damage.

Unit Controls and Safety Devices

HIGH-PRESSURE RELIEF VALVES (except 50HQ,VQ014) is located in compressor. Relief valve opens at a pressure differential of approximately 550 psi between suction (low side) and discharge (high side) to allow pressure equalization.

CURRENT AND TEMPERATURE SENSITIVE OVERLOAD (linebreak) internal on all compressors except on 50HQ,VQ014 which has external shell mounted overload. Overload resets automatically when internal compressor motor temperature drops to a safe level (overloads may require up to 45 minutes to reset). When an internal overload is suspected of being open, check by using an ohm-

meter or continuity tester. If necessary, refer to Carrier Standard Service Techniques Manual, Chapter 2, for complete instructions.

HIGH-PRESSURE SWITCH opens and shuts compressor off if discharge pressure rises above 395 psig. Switch closes at 295 psig.

FREEZE-UP PROTECTION — Two controls are used to prevent unit from operating if water approaches freezing temperature.

1. Low Water Temperature Cutout (LWTC) — shuts unit off and energizes lockout relay if water temperature reaches 37 F.
2. Lockout Relay — locks itself in energized position and prevents unit from starting.

The unit can be restored to heating operation if the water temperature rises to 42 F, where the LWTC will reset, and if the thermostat circuit is interrupted either by lowering the thermostat setting or by moving system switch to OFF or COOL. Thermostat may then be readjusted to normal set point.

HEAT PUMP CIRCUITS shown in Fig. 8 are refrigerant and water flow diagrams for heating and cooling cycles.

SERVICE

Refrigerant Charging — Unit refrigerant system is factory charged. When recharging is necessary

during heating or cooling season, weigh in total charge indicated in Table 4. Remove any refrigerant remaining in system before recharging. If system has lost complete charge, evacuate system to 500 microns (29.7 in. vacuum) before recharging. Service port connections are provided on high and low sides of refrigerant system for evacuation and charging. (See Fig. 8 for service port location.)

Dial-a-charge charging cylinder is an accurate device used to recharge systems by weight. These cylinders are available at refrigeration supply firms.

To check and/or adjust refrigerant charge during cooling season, use correct cooling cycle charging chart (Fig. 9, 11, 13, 15, 17, 19) or Carrier Charge-master® charging device (Carrier Part No. 38GC680004). Charging charts or Chargemaster may also be used as alternate methods of recharging system. Charging methods are described below.

To check *system operation* during heating cycle, use correct Heating Cycle Operation Check Chart (Fig. 10, 12, 14, 16, 18, 20). These charts indicate whether a correct relationship exists between unit operating pressures and water temperature leaving heat exchanger. If pressure and water temperature lines do not intersect on chart, the system refrigerant charge may not be correct or other system abnormalities may exist. Do not use Operation Check Charts to adjust refrigerant charge. Weigh charge into system.

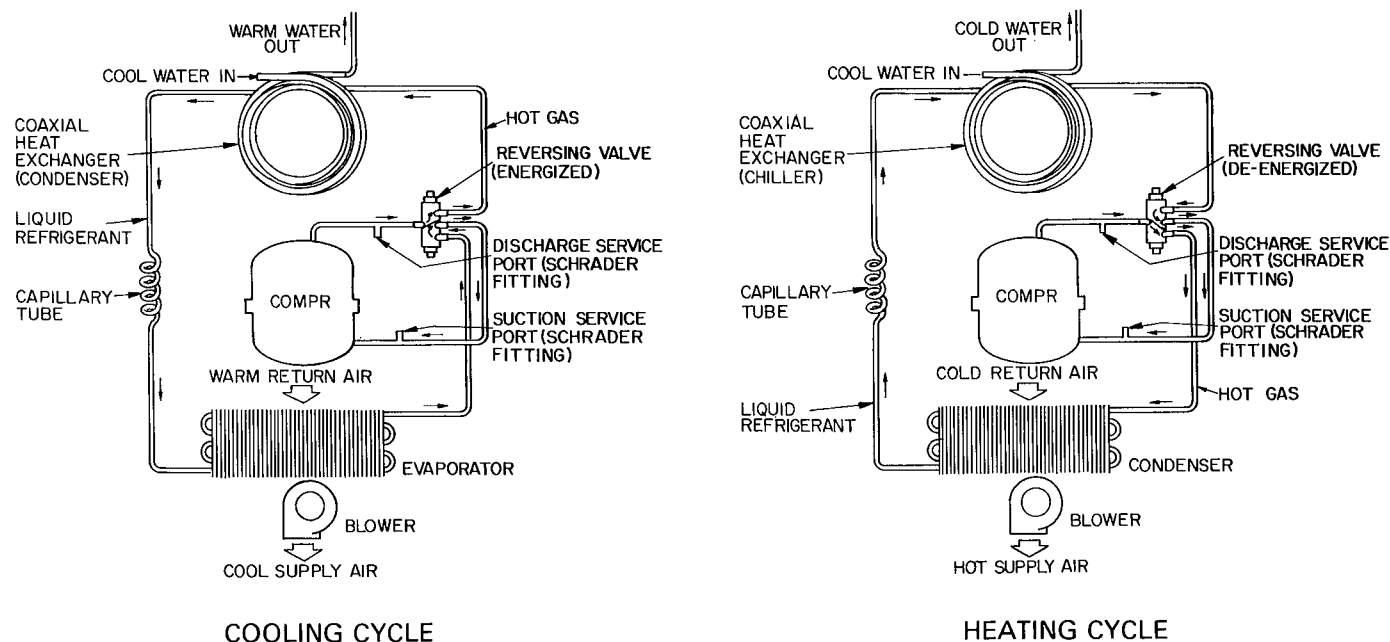

Water In/Water Out can be to a ground water or surface water source

Fig. 8 — Refrigerant and Water Flow Diagrams — 50HQ,VQ

Table 4 — Service Data

UNIT 50HQ,VQ	014	018	022	027	033	042	048	060	080
R-22 CHG (lb-oz)* Refrig Control	1-8	1-10	2-1	2-0	2-3	2-11	—	—	—
Capillary Tube									
FAN	Centrifugal — Direct Drive								
Diameter (in. Nom)	10	10	10	10	10	11	10	10	12
Width (in. Nom)	7	7	7	7	7	7	8	10	9
Range Cfm	400-600	500-700	600-800	750-1000	950-1200	1040-1375	1400-1800	1750-2250	2300-3000
Motor Hp	1/8	1/8	1/6	1/6	1/4	1/3	1/2	3/4	1
Motor Rpm (3-speed)	1075 Nominal								
HEAT EXCHANGER WATER FLOW RATE (Gpm)	2.5-5	3-6	4-8	4.5-9	5-10	6-12	7-14	8.5-17	11.5-23

*Factory refrigerant charge

COOLING CYCLE CHARGING CHART METHOD

1. Operate unit a minimum of 10 minutes before checking charge, and after each charge adjustment.
2. Measure suction pressure by attaching a gage to unit suction service port (Schrader Fitting).
3. Measure discharge pressure by attaching a gage to unit discharge service port (Schrader Fitting).
4. Using a sling psychrometer, measure wet-bulb temperature of air entering unit.
5. Refer to correct Charging Chart. Locate on curves where unit discharge pressure line and indoor air wet-bulb temperature line intersect.
6. From intersect point, project horizontally left to chart suction pressure line. Compare chart suction pressure to unit suction pressure (step 2).
7. If unit suction pressure is lower than chart pressure, add refrigerant to unit until chart pressure is reached. If unit suction pressure is higher than chart pressure, remove refrigerant until chart pressure is reached.

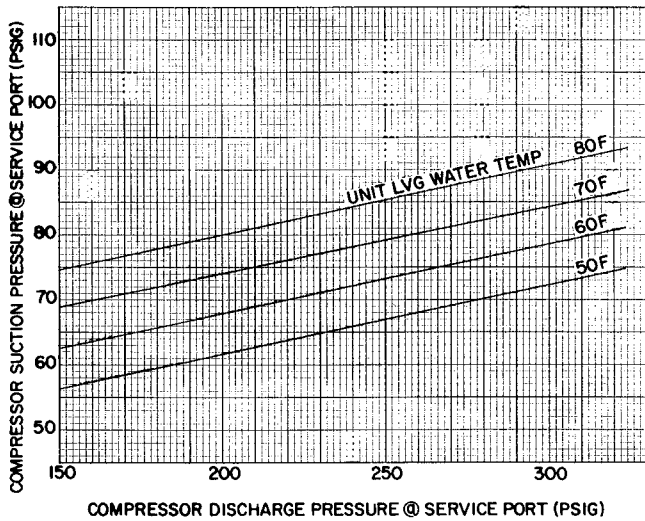

Fig. 10 — Heating Cycle Operation Check Chart (R-22) — 50HQ,VQ014

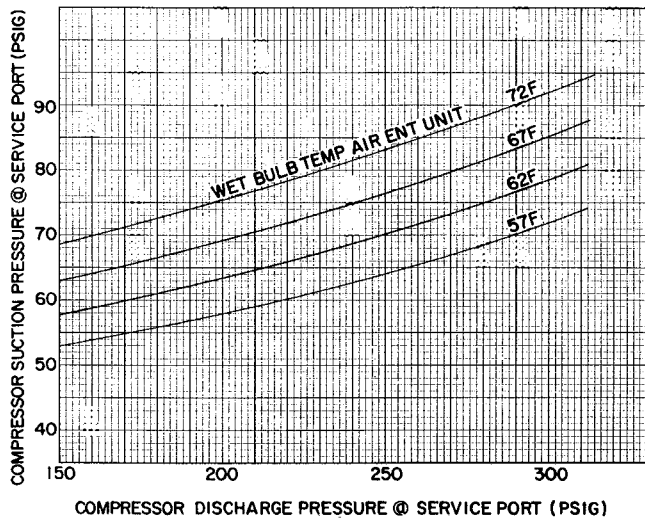

Fig. 11 — Cooling Cycle Charging Chart (R-22) — 50HQ,VQ018

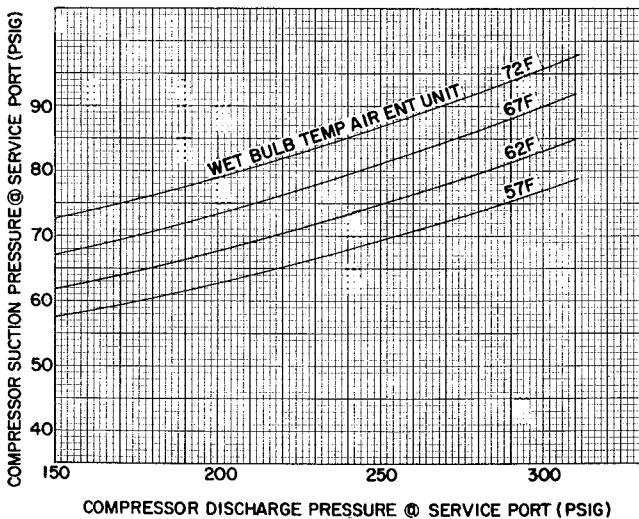

Fig. 9 — Cooling Cycle Charging Chart (R-22) — 50HQ,VQ014

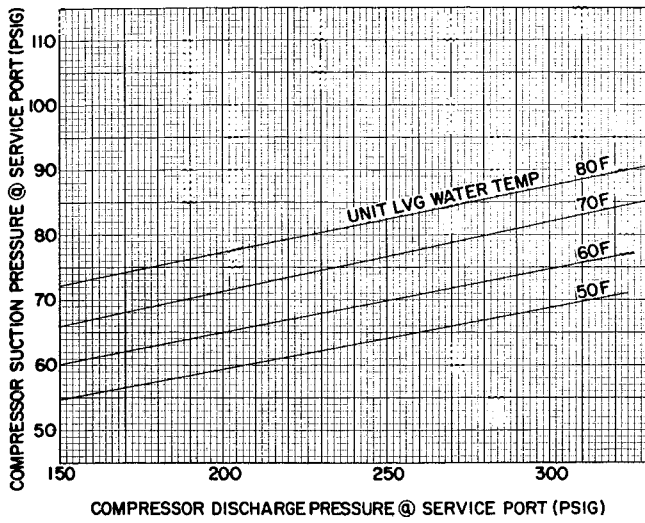

Fig. 12 — Heating Cycle Operation Check Chart (R-22) — 50HQ,VQ018

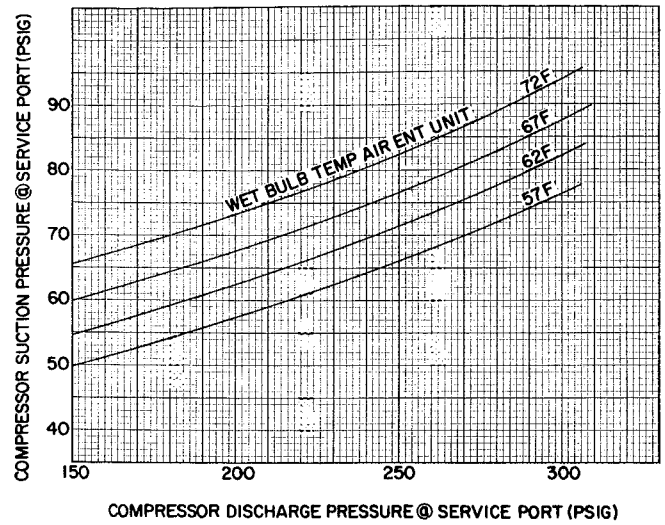

Fig. 15 — Cooling Cycle Charging Chart (R-22) — 50HQ,VQ027

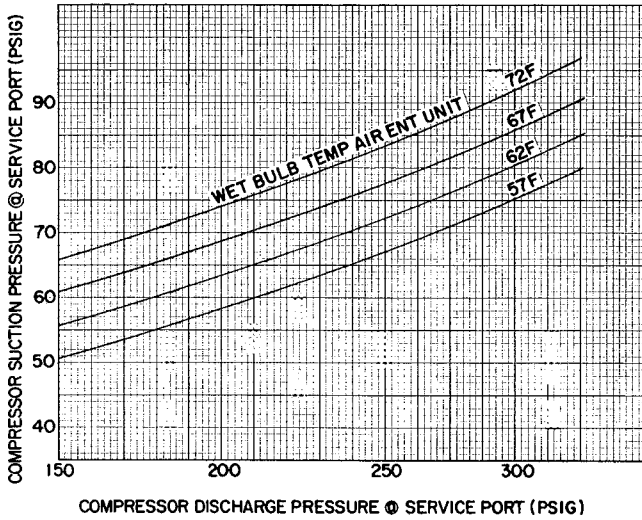

Fig. 13 — Cooling Cycle Charging Chart (R-22) — 50HQ,VQ022

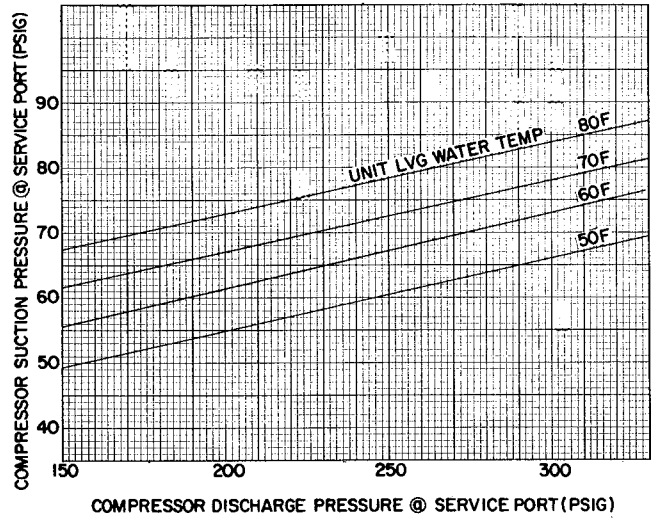

Fig. 16 — Heating Cycle Operation Check Chart (R-22) — 50HQ,VQ027

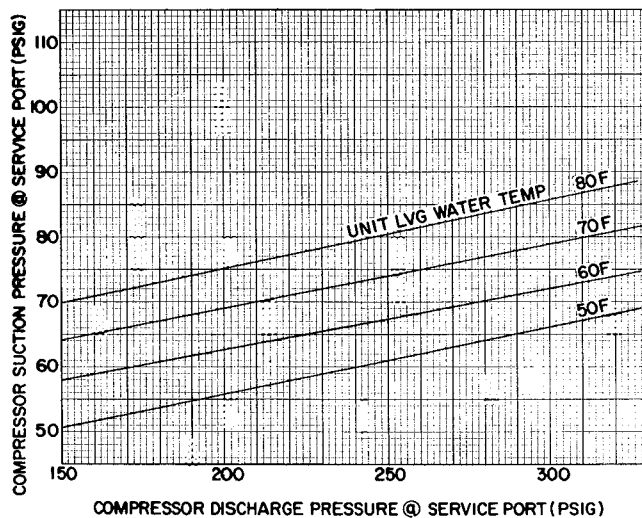

Fig. 14 — Heating Cycle Operation Check Chart (R-22) — 50HQ,VQ022

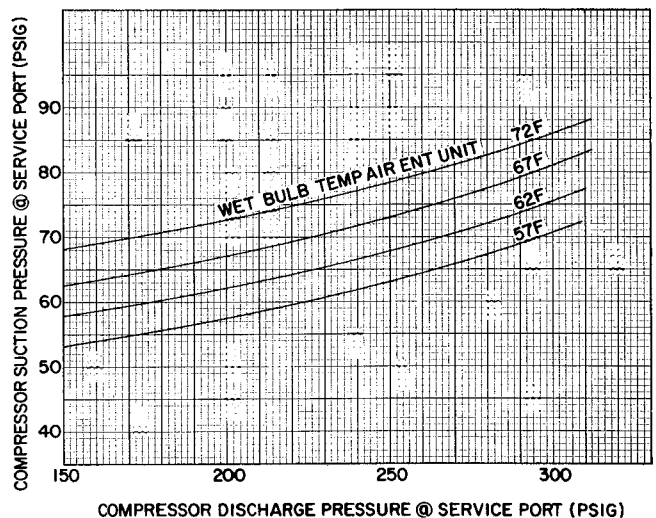

Fig. 17 — Cooling Cycle Charging Chart (R-22) — 50HQ,VQ033

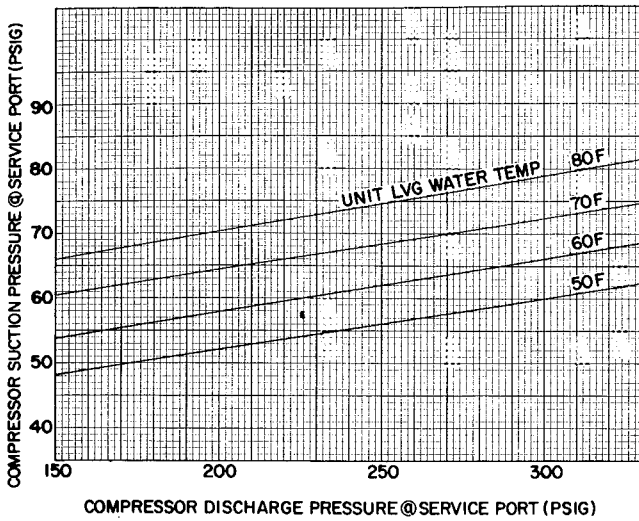

Fig. 18 — Heating Cycle Operation Check Chart (R-22) — 50HQ,VQ033

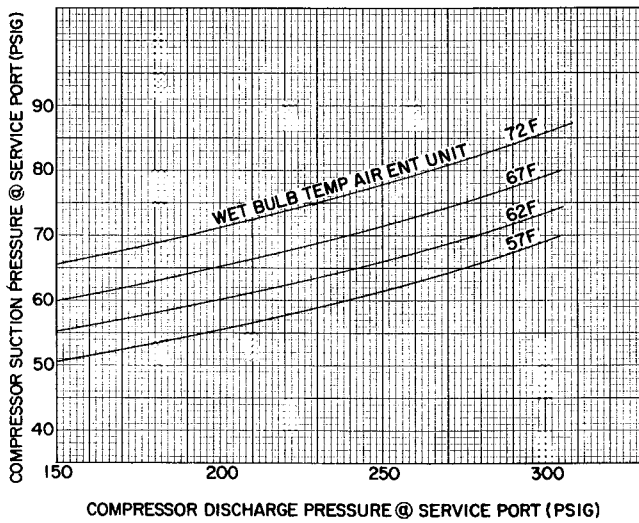

Fig. 19 — Cooling Cycle Charging Chart (R-22) — 50HQ,VQ042

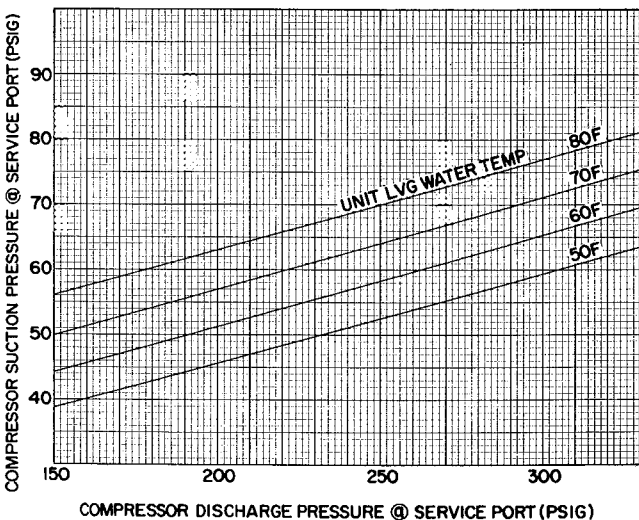

Fig. 20 — Heating Cycle Operation Check Chart (R-22) — 50HQ,VQ042

CHARGEMASTER® DEVICE OPERATION — Operate unit 10 minutes before using Chargemaster. Ensure unit indoor fan section access panel is in place for proper Chargemaster operation.

1. Tape Chargemaster feeler bulb to unit suction line. Insulate bulb. Ensure suction line is clean for good contact with bulb.
2. Connect refrigerant drum to Chargemaster inlet port with drum in position for vapor charging.
3. Connect Chargemaster outlet port (loosely) to unit suction line Schrader valve.
4. Crack valves on refrigerant drum and Chargemaster to purge lines from drum to suction line Schrader valve. After purging lines, close valve on Chargemaster only. Tighten Chargemaster connection at suction line Schrader valve.
5. Measure unit leaving water temperature.
6. Read *evaporator temperature at red needle position* on Chargemaster temperature gage and *suction line temperature at black needle position*.

CAUTION: Do not read evaporator temperature with Chargemaster valve open.

7. Enter 50HQ,VQ Chargemaster Charging Chart, Table 5, at unit leaving water temperature (step 5) and evaporator temperature (step 6). (*Do not use standard charging chart on cover of Chargemaster.*) Find the suction line temperature required for correct system charge. If actual suction line temperature (step 6) is higher than table value, the system is undercharged. If suction line temperature is lower than table value, the system is overcharged.

Example: At leaving water temperature of 93 F and evaporator temperature of 41 F, the system is correctly charged at 50 F (± 2 F) suction line temperature.

Table 5 — Chargemaster Charging Chart

UNIT LEAVING WATER TEMP (F)	EVAPORATOR TEMP (F)*									
	30	33	36	39	41	44	47	50	53	56
69	46	49	51	54	57	59	61			
75	45	47	50	53	55	58	60	64		
81		46	49	51	54	56	57	63		
87			48	50	52	54	56	62	65	
93			46	48	50	53	55	57	61	
99				47	49	51	54	56	61	64
105				45	47	50	53	56	60	63
112					46	49	53	55	59	62
117					45	47	52	55	57	61
123						46	50	53	55	56

*Saturated evaporator temperature which is the equivalent temperature of pressure taken at unit suction service valve

8. Add charge by slowly opening Chargemaster valve. If necessary, reduce charge by bleeding at liquid line Schrader valve. Check outdoor air and evaporator temperature during procedure. If they change, refer back to Chargemaster Charging Chart for new value.

Correct use of Chargemaster ensures that an optimum refrigerant charge is in system when conditions and system components are normal. However, the Chargemaster does not solve or fix system abnormalities. It indicates correct charge for condition of system. It does not make corrections for dirty filters, slow fans, or other abnormal conditions. This charging device ensures that a correct relationship exists between leaving water temperature, evaporator temperature, and suction line temperature on a specific system.

Table 6 — Compressor Data

UNIT 50HQ,VQ	V/PH	PRODUCTION COMPRESSOR	OIL RECHARGE (oz)
014	208/230-1	AJ5513F	24
018		AB5519F	32
022		MD2023FE	42
027		MD2423FE	42
033		MD3423FE	42
042		MD4023FE	42
048		PC4616AD	72
060		PC6016AD	72
033	208/230-3	MF3423FE	42
042		MF4023FE	42
048		PY4616AD	72
060		PY6016AD	72
080		PY7716AF	72
033	460/3	MH3423FE	42
042		MH4023FE	42
048		PH4616AD	72
060		PH6016AD	72
080		PH7716AF	72

Compressor Removal

See Table 6 for compressor information and Fig. 7 for component location. Follow safety codes, and wear safety glasses and work gloves. Have quenching cloth available (step 7).

CAUTION: Copper tubing and aluminum fins are used in unit coils. Do not overheat or place excessive strain on tubing or damage may result.

1. Shut off power to unit. Failure to do so may result in electrical shock. Remove unit compressor section access panels, Fig. 1 and 5.
2. Remove refrigerant from unit using refrigerant removal methods described in Carrier Standard Service Techniques Manual, Chapter 1.
3. Remove core from suction and discharge line Schrader valves.

4. Disconnect compressor wiring at compressor terminal box.
5. Using a tubing cutter, cut suction and discharge lines at convenient place near compressor for easy reassembly to new compressor with copper slip couplings.

CAUTION: Excessive movement of copper lines at compressor may cause a break where lines connect to coil.

6. Remove compressor hold-down bolts and lift compressor out.
7. Carefully unbrazed suction and discharge line piping stubs from compressor. If oil vapor in piping stubs ignites, use quenching cloth.
8. Braze piping stubs (removed in step 7) on new compressor.
9. Clean system.
10. Install new compressor in unit. Braze suction and discharge lines to compressor piping stubs (at points where cut, step 5) using field-supplied copper couplings. Ensure compressor hold-down bolts are in place. Connect wiring.
11. Evacuate and recharge unit.

CAUTION: Before performing recommended maintenance, be sure main power switch to unit is turned off.

Lubrication

COMPRESSOR contains factory oil charge. Replace oil when lost. See Table 6 for oil recharge. If necessary, refer to Carrier Standard Service Techniques Manual, Chapter 1, pages 1-21, for oil recharging procedure. Use Carrier PP33-1, Texaco Capella B or Suniso 3G oil.

FAN MOTOR BEARINGS are prelubricated for 3 years heavy-duty or 5 years normal-duty service.

Cleaning Coil and Condensate Pan — Clean and inspect coil, condensate pan and drain before each cooling season.

1. Remove coil section access panels and slide air filter out of filter flanges.
2. Disconnect condensate drain line at pan drain connection.
3. Use vacuum cleaner nozzle to clean the face of coil.
4. Clean condensate drain trap with a bottle brush. Clean condensate pan.
5. Hold pail under condensate pan drain connection and flush pan out with clean water. Ensure water flows freely thru condensate drain. Do not overflow pan.
6. Reconnect condensate drain line.
7. Install access panel and air filter.

Indoor Fan Wheel should be centered in housing. To adjust fan, loosen setscrew holding fan to motor shaft. Adjust fan and retighten setscrew.

50VQ INDOOR BLOWER ASSEMBLY REMOVAL

1. Remove fan section access panel.
2. Remove power wires from Molex plug.
3. Place a spacer beneath blower housing for support.
4. Remove blower assembly mounting bracket. (Rear flange on top of blower housing and spacer now hold blower assembly in place.)
5. Support blower housing at bottom and remove spacer. Tilt blower assembly downward and lift out of unit.

50HQ INDOOR BLOWER ASSEMBLY REMOVAL

1. Remove top cover (Fig. 2).
2. Remove power wires from Molex connector (Fig. 7).
3. Remove blower assembly mounting screws from base unit (Fig. 2).
4. Lift blower assembly out of unit.

Indoor Fan and Motor Removal

1. Remove blower assembly from unit.

2. Remove Molex plug from bracket on fan housing.
3. Loosen setscrew holding fan to motor shaft.
4. Loosen motor mounting band and remove motor.
5. Remove fan cutoff plate from blower housing outlet.
6. Remove fan wheel from blower housing outlet.

Clean Indoor Fan Wheel — When coil is cleaned, remove caked-on dirt from fan wheel and housing with brush; remove grease with mild solvent. When replacing blower assembly, make sure fan wheel is centered in housing.

Return Air Filter — Replace filter media 4 times a year. For other types of filters, refer to filter manufacturer's instructions as required.

CAUTION: Never operate unit without a filter as coil will plug and damage to fan motor may result.

Heat Exchanger — If excessive discharge pressure is experienced with normal water flow, the heat exchanger tubes may be fouled and require cleaning. Contact a local water treatment firm for details on chemical cleaning.

TROUBLESHOOTING CHART

PROBLEM	CAUSE	CORRECTION
ENTIRE UNIT DOES NOT RUN	Blown fuse	Replace fuse or reset circuit breaker
	Broken or loose wires	Replace or tighten the wires
	Voltage supply low	If voltage is below minimum voltage specified on dataplate, contact local power company
	Transformer	Check 24-volt transformer for burnout or voltage less than 18 volts
	Thermostat	Set thermostat on COOL and lowest temperature setting, unit should run. Set thermostat on HEAT and highest temperature setting, unit should run. Set fan to ON, fan should run. If unit does not run in all 3 cases, the thermostat could be wired incorrectly, or faulty. To ensure faulty or miswired thermostat, disconnect thermostat wires at unit and jumper between R, Y, G, and W terminals and unit should run.
BLOWER OPERATES BUT COMPRESSOR DOES NOT	Voltage supply low	If voltage is below minimum voltage specified on the dataplate, contact local power company
	Thermostat	Check setting, calibration and wiring
	Wiring	Check for loose or broken wires at compressor, capacitor or contactor.
	High pressure controls	The unit could be off on the high pressure cutout control. Reset the thermostat to OFF. After a few minutes turn to COOL. If the compressor runs, unit was off on high pressure. (See Problems for possible causes.) If the unit still fails to run, check for faulty pressure switch by jumpering the high pressure control.
	Defective capacitor	Check capacitor or Start Thermistor (PTC). If defective, remove, replace and revise correctly.
	Seized compressor	Try a start capacitor in parallel with the run capacitor momentarily. If the compressor starts but the problem reoccurs on starting, install an auxiliary start kit. The hard start kit is comprised of a recommended start relay and correctly sized capacitor. If the compressor still does not start, replace the compressor.
	Compressor overload open	In all cases, an external or internal temperature sensitive compressor overload is used. If the compressor dome is too hot to touch, the overload will not reset until the compressor cools down. If the compressor is cool and the overload does not reset, there may be a defective or open overload. If the overload is external, replace the overload, otherwise replace the compressor.
	Compressor motor grounded Compressor windings open	Internal winding grounded to the compressor shell. Replace the compressor. Check continuity of the compressor windings with an ohmmeter. If the windings are open, replace the compressor.
Low water temperature cutout open (LWTC)	The unit could be off on the LWTC. Reset the thermostat to OFF. After a few minutes, turn to HEAT. If the compressor runs, unit was off on LWTC (see Problems for possible causes).	
UNIT OFF ON LOW WATER TEMPERATURE CONTROL	Water temperature too low on heating	Lack of or inadequate water flow. Entering water too cold. Scaled or plugged heat exchanger.
	Low water temperature switch	Check for defective or improperly calibrated low water temperature switch
UNIT CYCLING ON HIGH-PRESSURE CUTOUT CONTROL	Discharge pressure too high	On COOLING cycle: Lack of or inadequate water flow. Entering water too warm. Scaled or plugged heat exchanger. On HEATING cycle: Lack of or inadequate airflow Entering air too hot. Blower inoperative, clogged filter or coil, restrictions in ductwork.
	Refrigerant charge	The unit is overcharged with refrigerant. Bleed off some charge or evacuate and recharge with specified amount of R-22
	High pressure switch	Check for defective or improperly calibrated high pressure switch.
UNIT SHORT CYCLES	Wiring and controls	Loose connections in the wiring or the control contactors defective
	Compressor overload	Defective compressor overload, check and replace if necessary. If the compressor runs too hot, it may be due to the deficient refrigerant charge
INSUFFICIENT COOLING OR HEATING	Unit undersized	Recalculate heat gains or losses for space to be conditioned. If excessive, rectify by adding insulation, shading, etc.
	Loss of conditioned air by leaks	Check for leaks in ductwork or introduction of ambient air thru doors and windows.
	Thermostat	Improperly located thermostat (e.g. near kitchen sensing inaccurately the comfort level in living areas).
	Airflow	Lack of adequate airflow or improper distribution of air
	Refrigerant charge	Low on refrigerant charge causing inefficient operation
	Compressor	Check for defective compressor. If discharge pressure is too low and suction pressure is too high, compressor is not pumping properly. Replace compressor
	Reversing valve	Defective reversing valve creating bypass of refrigerant from discharge to suction side of compressor
	Operating pressure	Incorrect operating pressure. (See chart)
Refrigerant system	Check strainer and capillary tubes for possible restrictions to flow of refrigerant. The refrigerant system may be contaminated with moisture, noncondensables, and particles. Dehydrate, evacuate and recharge the system	

TROUBLESHOOTING CHART (cont)

PROBLEM	CAUSE	CORRECTION
NOISY OPERATION	Compressor	Make sure the compressor is not in direct contact with the base or sides of the cabinet. The hold-down bolts used for shipping should be loosened so that the compressor is floating free on its isolator mounts. Excessive noise will occur if the compressor has a broken valve or loose discharge tube. Replace the compressor.
	Blower and blower motor	Blower wheel hitting the casing. Adjust for clearance and alignment. Bent blower, check and replace if damaged. Loose blower wheel on shaft. Check and tighten. Defective bearings, check and replace.
	Contactors	A clattering or humming noise in the contactor could be due to control voltage less than 18 volts. Check for low supply voltage, low transformer output or extra long runs of thermostat wires. If the contactor contacts or coil is defective, repair or replace.
	Rattles and vibrations	Check for loose screws, panels or internal components. Tighten and secure. Copper piping could be hitting the metal surfaces. Carefully readjust by bending slightly.
	Airborne noises and other sounds	Undersized ductwork will cause high airflow velocities and noisy operation. Excessive water thru the water-cooled heat exchanger will cause a rattling sound. Throttle back on the water flow ensuring adequate flow for good operation but eliminating the noise.

For replacement items use Carrier Specified Parts.

Manufacturer reserves the right to discontinue, or change at any time, specifications or designs without notice and without incurring obligations.

Book	1	4
Tab	5a	5a

Free Manuals Download Website

<http://myh66.com>

<http://usermanuals.us>

<http://www.somanuals.com>

<http://www.4manuals.cc>

<http://www.manual-lib.com>

<http://www.404manual.com>

<http://www.luxmanual.com>

<http://aubethermostatmanual.com>

Golf course search by state

<http://golfingnear.com>

Email search by domain

<http://emailbydomain.com>

Auto manuals search

<http://auto.somanuals.com>

TV manuals search

<http://tv.somanuals.com>