

CD ROM Upgrade 4X CD-ROM Drives

User Guide

On-line Version

CD-ROM UPGRADE

Creative GCD-R542B CD-ROM Drive

User's Guide

Information in this document is subject to change without notice and does not represent a commitment on the part of Creative Technology Ltd. The software described in this document is furnished under a license agreement and may be used or copied only in accordance with the terms of the license agreement. It is against the law to copy the software on any other medium except as specifically allowed in the license agreement.

The licensee may make one copy of the software for backup purposes. No part of this manual may be reproduced or transmitted in any form or by any means, electronic or mechanical, including photocopying and recording, for any purpose without the written permission of Creative Technology Ltd.

Copyright 1995 by Creative Technology Ltd. All rights reserved.

Version 1.0
August 1995

Sound Blaster is a registered trademark of Creative Technology Ltd.

Sound Blaster 16 is a trademark of Creative Technology Ltd.

IBM is a registered trademark of International Business Machines Corporation.

MS-DOS is a registered trademark and Windows is a trademark of Microsoft Corporation.

All other products are trademarks or registered trademarks of their respective owners.

Regulatory Information

The following sections consist the notice for the USA and Canada.

Notice for the USA

FCC Part 15: This equipment has been tested and found to comply with the limits for a Class B digital device, pursuant to Part 15 of the FCC Rules. These limits are designed to provide reasonable protection against harmful interference in a residential installation. This equipment generates, uses, and can radiate radio frequency energy and, if not installed and used in accordance with the instructions, may cause harmful interference to radio communications. However, there is no guarantee that interference will not occur in a particular installation. If this equipment does cause harmful interference to radio or television reception, which can be determined by turning the equipment off and on, the user is encouraged to try one or more of the following measures:

- Reorient or relocate the receiving antenna.
- Increase the separation between the equipment and receiver.
- Connect the equipment into an outlet on a circuit different from that to which the receiver is connected.
- Consult the dealer or an experienced radio/TV technician for help.

Caution

To comply with the limits for the Class B digital device, pursuant to Part 15 of the FCC Rules, this device must be installed in computer equipment certified to comply with the Class B limits.

All cables used to connect the computer and peripherals must be shielded and grounded. Operation with non-certified computers or non-shielded cables may result in interference to radio or television reception.

Modifications

Any changes or modifications not expressly approved by the grantee of this device could void the user's authority to operate the device.

Notice for Canada

This apparatus complies with the Class "B" limits for radio interference as specified in the Canadian Department of Communications Radio Interference Regulations.

Cet appareil est conforme aux normes de CLASSE "B" d'interférence radio tel que spécifiée par le Ministère Canadien des Communications dans les règlements d'interférence radio.

Safety Information

CAUTION: This CD-ROM is intended to be installed by the user in a CSA/TUV/UL certified/listed IBM AT or compatible personal computers in the manufacturer's defined operator access area. Check the equipment operating/installation manual and/or with the equipment manufacturer to verify/confirm if your equipment is suitable for user-installed application cards.

ATTENTION: Cette CD-ROM est destinée à être installée par l'utilisateur, dans un ordinateur compatible certifié CSA/TUV/UL ou listé IBM AT, à l'intérieur de la zone définie par le fabricant. Consulter le mode d'emploi ou le fabricant de l'appareil pour vérifier ou confirmer si l'utilisateur peut y installer lui-même des cartes périphériques.

Compliance

This product is in conformity to the following Council Directive:

- Directive 89/336/EEC, 92/31/EEC (EMC)

Introduction

This *User's Guide* provides you with information to install and operate your CD-ROM drive. It also provides you with information to install and use QuickCD, an application that allows you to play audio CDs in DOS and Windows.

Before You Begin

Before you set up your package, please read the following carefully:

- Checking System Requirements
- Obtaining Latest Information
- Making a Copy of Your Diskette

Checking System Requirements

The following are the system requirements:

- A 386SX or compatible computer (486SX recommended).
- 720 Kilobytes (KB) of hard disk space for the software.
- MS-DOS version 5.0 or later.
- Windows 3.1 or later.
- An audio card with IDE CD-ROM interface, an IDE CD-ROM interface card, or any device with an IDE interface.

Obtaining Latest Information

The README.TXT file on the diskette labeled CD-ROM Installation Disk contains the latest information and changes not available at the time of printing. Please read the file before you continue.

To view the file:

1. Insert the CD-ROM Installation Disk into drive A or B of your computer.
2. Type **A:README** (or **B:README**) and press <Enter>.

Making a Copy of Your Diskettes

If you have not made a copy of the original diskettes, you should do so before installing the software in your system. Store your original diskettes in a safe place.

Using this Guide

This guide is arranged as follows:

Chapter 1, “Knowing Your CD-ROM Drive”

Before you install your drive, you should read this chapter to become more familiar with your drive. This chapter acquaints you with the various components and features of your CD-ROM drive. This chapter is especially helpful if you are new to CD-ROM drives.

Chapter 2, “Setting Up Your CD-ROM Drive”

After you have acquired a general understanding of your CD-ROM drive, you will be able to set up your CD-ROM drive easily and quickly. This chapter shows you how to install the drive and run the test program to ensure that your installation is successful.

Chapter 3, “Using QuickCD”

When you install your CD-ROM drive, the installation program copies QuickCD to your system. QuickCD is a program that plays audio CDs in DOS or Windows. This chapter describes how to run this program in both environments.

Chapter 4, “Doing More with Your CD-ROM Drive”

This chapter comprises several sections to help you get more out of your CD-ROM drive. These sections provide you with additional information about your drive e.g., changing the parameters of your CD-ROM drivers, and connecting additional drives.

Appendix A, “Technical Data”

If you want to know more about the physical dimensions, performance characteristics, and other specifications of your CD-ROM drive, you can refer to this appendix.

Appendix B, “Resolving Hardware Conflicts”

The base I/O address or IRQ line of the IDE CD-ROM interface card might conflict with the I/O address or IRQ line of other devices. Read this appendix on how to resolve these conflicts by changing your card’s jumpers.

Appendix C, “Troubleshooting”

If you encounter problems during installation or normal use, you need to know how to resolve them. This appendix provides solutions for some of the problems you might encounter.

Appendix D, “Glossary”

This appendix explains the technical terms used in this guide.

Appendix E, “Technical Support”

If you still cannot resolve a problem after looking at Appendix C, you can call our Technical Support service. This appendix provides information on where you can get help.

Document Conventions

This guide follows certain conventions to help you locate and identify the information that you need. These conventions are described in the following sections:

- ❑ Text Conventions
- ❑ Key Combinations
- ❑ Icons

Please note that in this guide, installed directory or *path* refers to the directory where your CD-ROM’s software is stored (e.g., SBCD).

Text Conventions

The following text elements are used to help you distinguish different types of information presented in this guide:

Table i: Text conventions used in this guide.

Text Element	Use
bold	Command names, switches, and any text that must be entered exactly as it appears.
<i>italics</i>	Title of a book. When presented at the DOS command line, it is a placeholder that represents information you must provide. This information usually appears in the parameter listing after the command is presented.
UPPERCASE	Directory name, file name, or acronym.
<>	Symbols, letters, and key names on the keyboard.

Key Combinations

In this guide, the following conventions are used to help you identify different key stroke combinations:



Table ii: Key conventions used in this guide.

Combination	Use
<Key1+Key2>	A plus sign (+) between key names means you must press the keys at the same time. For example, "Press <Ctrl+Z>" means press the <Ctrl> key and hold it down while you press the <Z> key.
<Key1,Key2>	A comma sign (,) between key names means you must press the keys in sequence. For example, "Press <Alt,F>" means press the <Alt> key and release it, and then press the <F> key and release it.

Icons

In this guide, icons are used to highlight areas of text that require your attention.

Table iii:Icons used in this guide.

Icon	Use
	Information or instructions that must not be taken lightly and should be noted.
	Cautions or warnings that you must pay attention to. Information highlighted by this icon tells you how to avoid situations such as the risk of not enough memory or even damages to your system.

Knowing Your CD-ROM Drive

Your CD-ROM drive is just like a CD player. It allows you to play audio CDs, skip and stop a track, and eject the CD using software application (see Chapter 3, “Using QuickCD”).

Furthermore, your drive supports the following features:

- ❑ **Quad Speed Transfer**
Your drive can supply a continuous stream of information at 600 KB per second to the PC’s bus. This higher transfer rate produces better performance when viewing Video for Windows or QuickTime movies and multimedia applications.
- ❑ **CD-ROM Standards**
Your drive meets the MPC level 2 requirements for CD-ROM. It also enables you to read CD-ROM/XA (Extended Architecture) — a specification that allows you to interleave data, audio, and video sectors on a CD.
- ❑ **Motorized Tray Loading System**
Your drive comes with a motorized tray loading system which allows you to load your CDs like a CD player.
- ❑ **Multiple Drives Support**
You can connect more than one CD-ROM drive to your PC. For more information on connecting additional drives, refer to the section “Connecting Additional Drives” in Chapter 4.

The rest of this chapter describes the components of your drive’s front and rear panels.

The Drive's Front Panel

This section describes the various controls on your drive's front panel as shown in Figure 1-1.

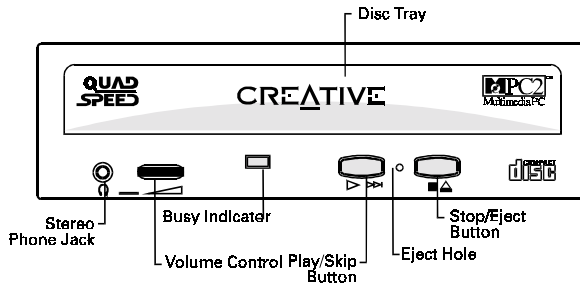

Figure 1-1: The front panel of your CD-ROM drive.

Stereo Phone Jack

The Stereo Phone Jack allows you to connect a pair of earphones to the drive. It also allows you to connect a pair of powered speakers. If you are connecting a pair of speakers to your drive, make sure that you switch on the speakers.

Volume Control

The Volume Control allows you to adjust the volume of your earphones or powered speakers connected to the front panel Stereo Phone Jack. This control has no effect on the audio output from devices (such as speakers) connected to your audio card.

Busy Indicator

The Busy Indicator lights up whenever your drive is reading data from your disc.

Play/Skip Button

The Play/Skip button allows you to play audio CDs when the CD-ROM drive is connected to your system's power supply. If your disc tray is ejected and loaded with a audio CD, pressing this button closes the tray and plays the audio CD.

While your audio CD is playing, you can press this button to skip a track. If you play a disc that does not contain any audio data, you will not hear any sound and the Busy Indicator blinks momentarily to signal the error.



You can operate your CD-ROM drive using controls on the drive's front panel or using applications such as QuickCD (see Chapter 3). If you are using the controls on the front panel, you cannot use QuickCD. Similarly, if you use QuickCD, you cannot use the controls.

Eject Hole

The Eject Hole allows you to eject the disc tray if the Eject/Stop button is disabled by a software or if power failure occurs. Refer to "Disc Tray" for more information on how to do so.

Stop/Eject Button

The Stop/Eject button stops playing a CD. It also allows you to eject or close the disc tray when the drive is not playing CD.



The Stop/Eject button will not eject the disc tray if the tray is locked by software application. To eject the disc tray, quit the application before you press the button.

Disc Tray

The disc tray is where you place your CD-ROM or audio CD. To eject button the tray, press the Stop/Eject button on your drive.

When placing the disc onto the tray, hold the disc by the inner and outer edges with the disc label facing up as shown in Figure 1-2.

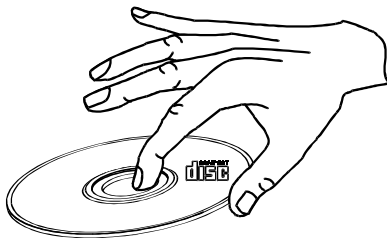

Figure 1-2: Holding a disc.



The disc tray can be locked using the LOCKCD.EXE utility (see the section “Locking the Disc Tray” in Chapter 4).

When there is a power or system failure, you can eject the disc tray by inserting a straightened paper clip into the Eject Hole and push hard (see Figure 1-3). Pull the ejected tray out gently as shown in Figure 1-4.

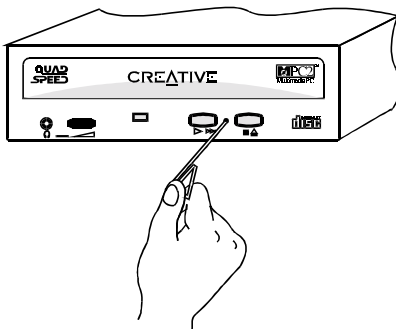

Figure 1-3: Inserting the straightened paper clip to eject the tray.



Please refrain from using excessive force to open the tray as this may damage your drive.

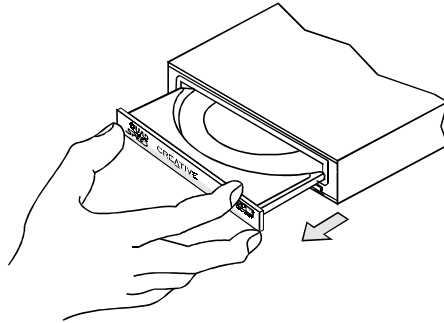

Figure 1-4: Pulling out the tray.

The Drive's Rear Panel

This section provides you with information on the connectors and jumpers found on your drive's back panel as shown in Figure 1-5.

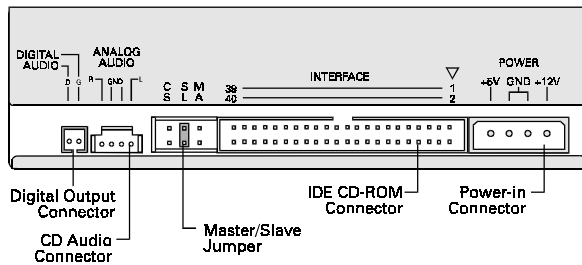

Figure 1-5: The rear panel of your CD-ROM drive.

Digital Output Connector

The Digital Output Connector allows your CD-ROM drive to provide digital output for recording to a digital audio tape (DAT) or professional audio recording system.

CD Audio Connector

The CD Audio Connector allows you to direct audio output from your CD-ROM drive to your audio card when it is connected using a CD audio cable.

Master/Slave Jumper

The Master/Slave Jumper (see Figure 1-6) allows you to set your drive as the Master or Slave drive. When you connect more than one drive, you must set your drive to be either a Master or Slave drive (see the section “Connecting Additional Drives” in Chapter 4). The jumper labeled CS is reserved and should not be used.

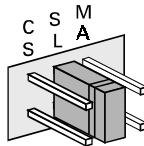

Figure 1-6: Master/Slave Jumper.

IDE CD-ROM Data Connector

The IDE CD-ROM Data Connector allows data transfer between your CD-ROM drive and various devices when connected using a data cable. These devices include your audio card (with an IDE interface), IDE CD-ROM interface card, and hard disk controller card.

Power-in Connector

The Power-in Connector allows electrical power to be directed from your PC to the drive when connected using a power cable.

Setting Up Your CD-ROM Drive

This chapter provides you with instructions to set up your CD-ROM drive. These instructions work:

- ❑ If you have purchased your CD-ROM drive as a stand-alone product or in a multimedia upgrade kit.
- ❑ If you have purchased your CD-ROM drive with a CD-ROM interface card.



If you are new to CD-ROM drives, we recommend that you read Chapter 1 before attempting to set up your drive.

Besides the CD-ROM drive, get the following items ready before setting up your drive (see Figure 2-1):

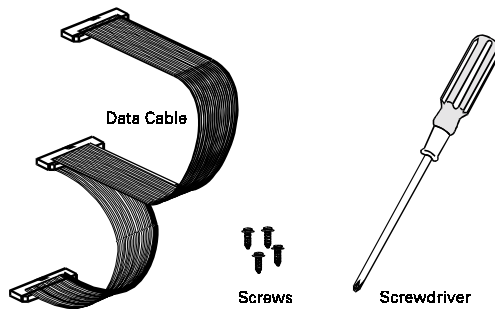

Figure 2-1: Items required for setting up your CD-ROM drive.



We recommend you to use a Philip Number One screwdriver as it is applicable to most systems. To avoid any damage to your drive, fasten the drive to your system using the screws (M3x5mm) provided.

If you have purchased the drive with an IDE CD-ROM interface card, get the interface card ready (see Figure 2-2).

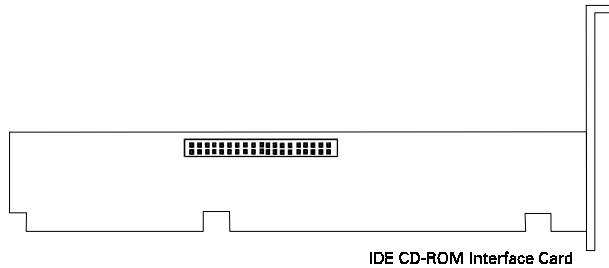

Figure 2-2: IDE CD-ROM interface card.

If you have an audio card installed in your system, get a CD audio cable ready (see Figure 2-3).

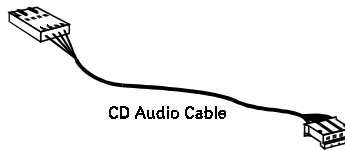

Figure 2-3: CD audio cable.

The rest of this chapter shows you how to:

- Install Your CD-ROM Drive
- Install the Software
- Test Your Installation

Installing Your Drive

To install your CD-ROM drive, you need to do the following:

- Insert Your Drive into Your System
- Connect Cables to Your Drive's Rear Panel
- Connect Cables to Your Card

Inserting Your Drive into Your System

To insert your drive into your system:

1. Switch off your system and all peripheral devices.
2. Touch a metal plate on your system to ground yourself and discharge any static electricity.
3. Remove the cover from your system as illustrated in Figure 2-4.

If your computer differs from the one shown below, refer to your computer's manual for more details.

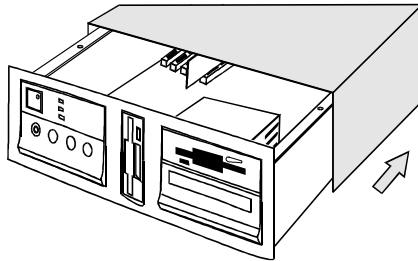

Figure 2-4: Removing the computer cover of your system.

4. Locate a 5¼" drive bay for your CD-ROM drive.
5. Vacate a drive bay.
If a disk drive is positioned above your vacant drive bay, loosen the screws of your disk drive and slide it out by two to three inches. See Figure 2-5.

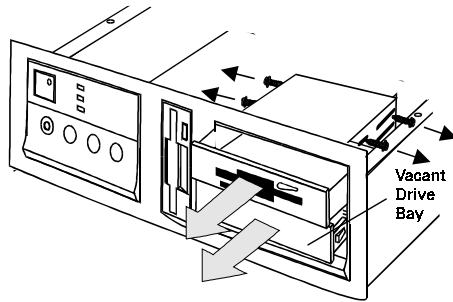

Figure 2-5: Vacating a drive bay.



For more information on how to vacate a drive bay, refer to your computer system's manual for assistance. If you require further help, please consult a technician.

6. Insert your CD-ROM drive into the vacant drive bay as shown in Figure 2-6.



Do not slide the drive completely into the vacant drive bay. Leave some space at the rear so that it is easier for you to connect cables to your drive.

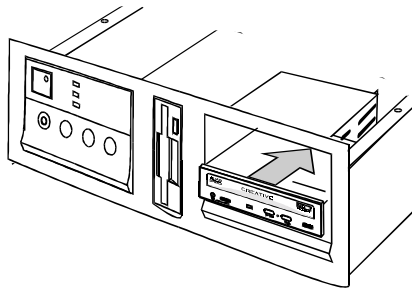

Figure 2-6: Inserting your CD-ROM drive.



You may need to use some force to insert your CD-ROM drive into your drive bay. However, please refrain from excessive force as this may damage your drive or other devices on your system.

Connecting Cables to Your Drive's Rear Panel

To connect all the necessary cables to the rear panel of your CD-ROM drive:

1. Locate an unused power cable from your system.
A power cable can be located from your system's power supply unit. The power supply unit is located at the right hand corner on most systems.

2. Connect the power cable to the CD-ROM drive as shown in Figure 2-7.

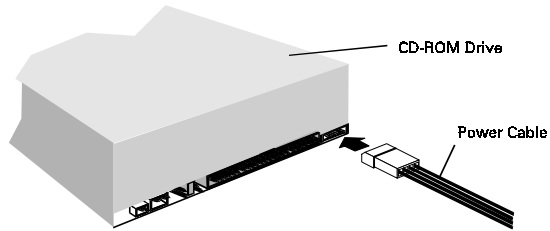

Figure 2-7: Connecting power cable to your CD-ROM drive.

3. Connect the data cable to the CD-ROM drive as shown in Figure 2-8. Make sure you align the colored wire on the cable to Pin 1 of the IDE CD-ROM Data Connector. If you are connecting your drive to your hard disk controller card, make sure that you use the data cable provided with your package to connect your drive (see Figure 2-1 on page 2-1).

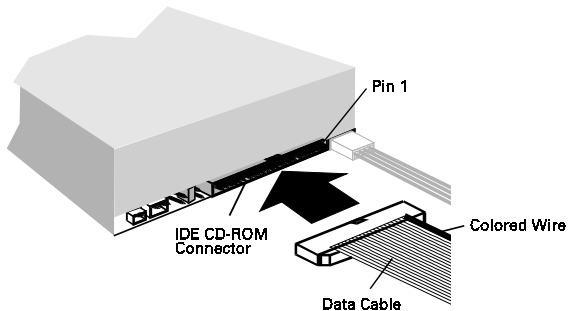

Figure 2-8: Connecting data cable to your CD-ROM drive.

4. If you are connecting your drive to an audio card, connect the CD audio cable to the CD-ROM drive as shown in Figure 2-9.

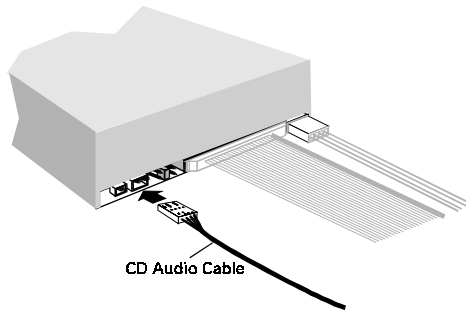

Figure 2-9: Connecting CD audio cable to your CD-ROM drive.

Connecting Cables to Your Card

After connecting the cables to the CD-ROM's rear panel, you need to connect these cables to your audio or IDE CD-ROM interface card.

If you have purchased the drive in a multimedia upgrade kit, read "Connecting Cables to Your Audio Card" in this section.

If you have purchased your drive with the IDE CD-ROM interface card, read "Connecting Cables to Your IDE CD-ROM Interface Card" in this section.

If you have purchased the drive as a stand-alone product, read "Connecting Cables to Your Audio Card" to connect the drive to an audio card or "Connecting Cables to Your IDE CD-ROM Interface Card" to connect the drive to an IDE CD-ROM interface card.



If you are connecting your drive to your hard disk controller card, read "Connecting Cables to Your Hard Disk Controller Card" in this section.

Connecting Cables to Your Audio Card

To connect the CD audio and data cables to your audio card (which has an IDE CD-ROM interface):

1. Connect the data cable to your audio card as shown in Figure 2-10. Make sure you align the colored wire on the cable to Pin 1 of the IDE CD-ROM Data Connector.



If your audio card has multiple CD-ROM data connectors, connect the data cable to the IDE CD-ROM Data Connector.

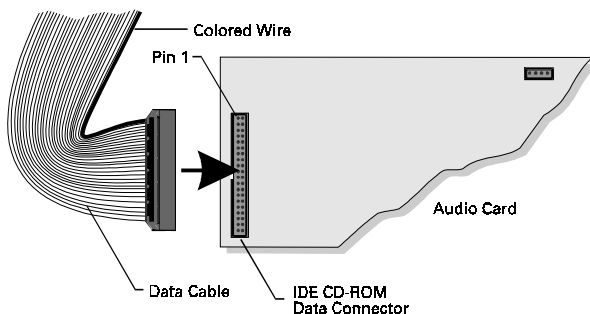

Figure 2-10: Connecting data cable to the audio card.

2. Connect the CD audio cable to your audio card as shown in Figure 2-11.

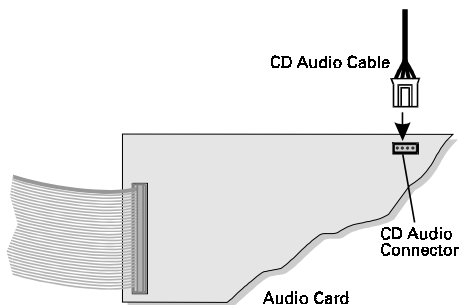

Figure 2-11: Connecting CD audio cable to the audio card.

3. Slide the drives back into place and fasten them to your system as shown in Figure 2-12.

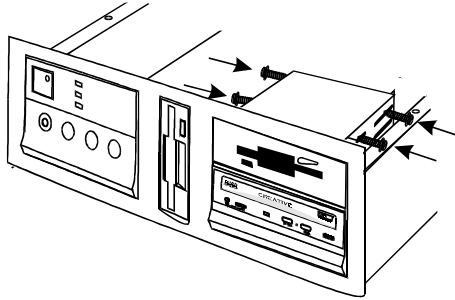

Figure 2-12: Fastening the drives to your system.

4. Switch on your system.
5. Proceed to the section “Installing the Software” in this chapter.

Connecting Cables to Your IDE CD-ROM Interface Card

If your drive comes with an IDE CD-ROM interface card, you need to install the interface card and connect it to your drive.

To install the interface card:

1. Locate a vacant 16-bit slot in your system (see Figure 2-13).

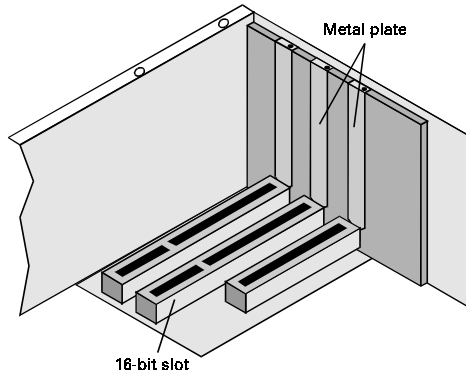

Figure 2-13: Locating a vacant slot.

2. Remove the metal plate from the slot you have chosen and put the screw aside (see Figure 2-14).

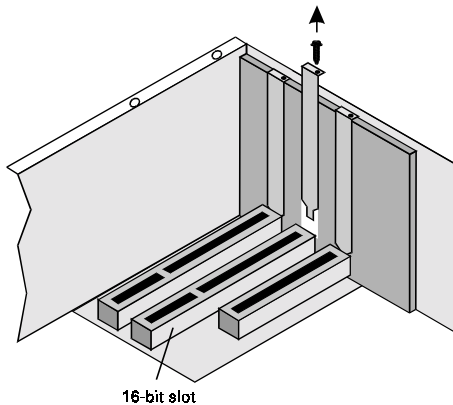

Figure 2-14: Removing the metal plate from the slot.

3. Align the IDE CD-ROM interface card's gold-stripped connector with the expansion slot and gently lower it into the slot (see Figure 2-15).

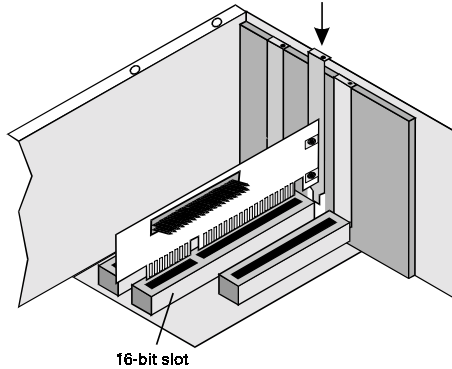

Figure 2-15: Inserting the IDE CD-ROM interface card.

4. Secure the interface card to the expansion slot with the screw you removed from the metal plate (see Figure 2-16).

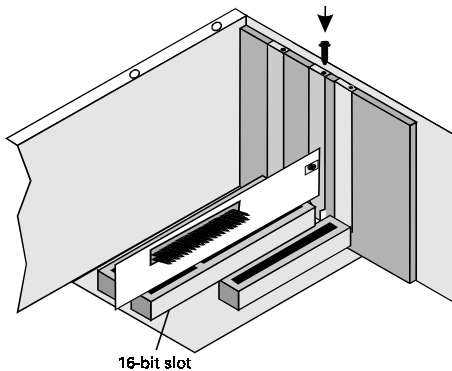

Figure 2-16: Fastening the IDE CD-ROM interface card to your system.

To connect the drive to the interface card:

1. Connect the data cable to your IDE CD-ROM interface card as shown in Figure 2-17. Make sure you align the colored wire on the cable to Pin 1 of the IDE CD-ROM Data Connector.

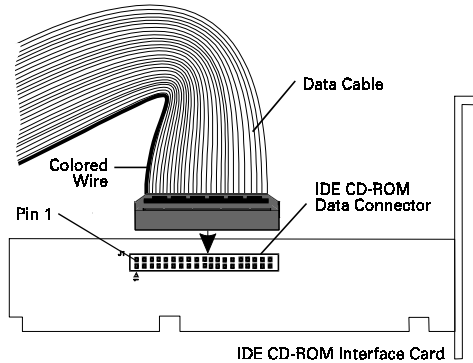

Figure 2-17: Connecting the data cable to the interface card.

2. If you have an audio card installed in your system, connect the CD audio cable to the CD Audio Connector on the audio card as shown in Figure 2-18.

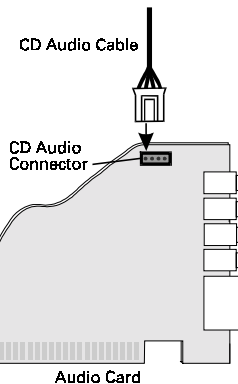

Figure 2-18: Connecting the CD audio cable to the audio card.

3. If you do not have an audio card installed in your system, connect a headphone or powered speakers to the Stereo Phone Jack on your drive's front panel. Set the volume controls of your drive and powered speakers to minimum before powering on (or resetting) the system. This is to prevent possible damage to the headphone or speaker.
4. Slide the drives back into place and fasten them to your system as shown in Figure 2-19.

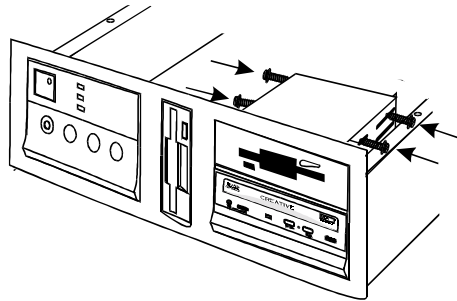

Figure 2-19: Fastening the drives to your system.

5. Switch on your system.
6. Proceed to the section “Installing the Software” in this chapter.

Connecting Cables to Your Hard Disk Controller Card

To connect the data cable to your hard disk and hard disk controller card:

1. If you have not backed up your hard disk, please do so before you proceed. For more information, refer to your DOS documentation.
2. Connect the power and data cables to your hard disk as shown in Figure 2-20. Make sure you align the colored wire on the cable to Pin 1 of your Hard Disk Data Connector.



The default setting for your CD-ROM drive is Slave drive. Make sure that your hard disk is set as the Master drive. For more information, refer to the documentation that comes with your hard disk.

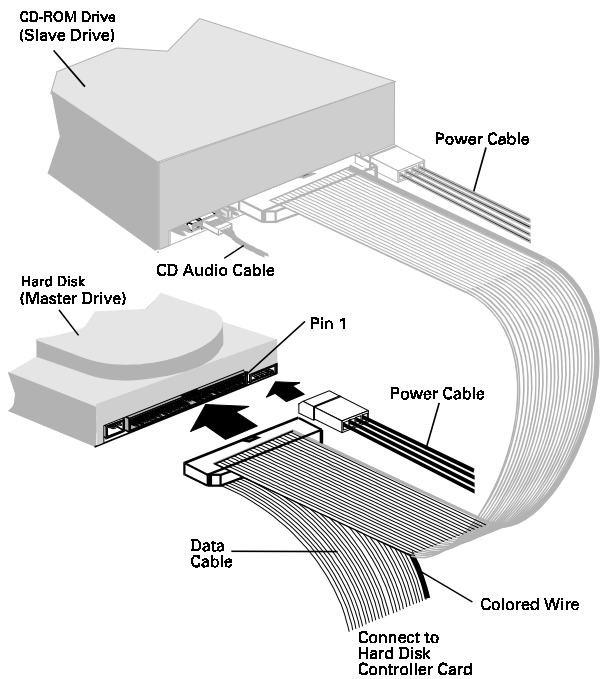

Figure 2-20: Connecting data cable to your hard disk.

3. Connect the data cable to your hard disk controller card as shown in Figure 2-21. Make sure you align the colored wire on the cable to Pin 1 of your Hard Disk Data Connector.



Your hard disk controller card may differ from the one shown in Figure 2-21.

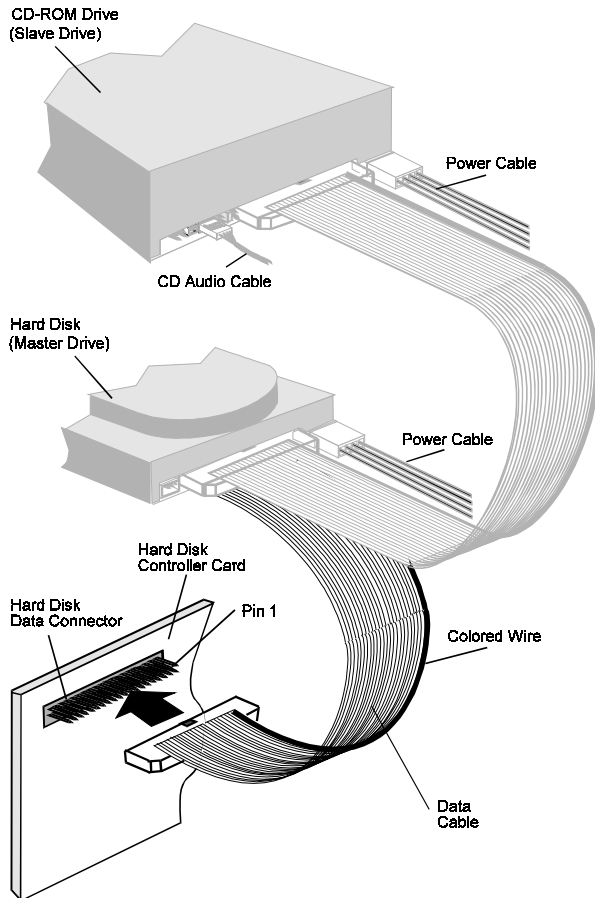

Figure 2-21: Connecting data cable to the hard disk controller card.

4. If you have an audio card installed in your system, connect the audio cable to the CD Audio Connector on the audio card as shown in CD Figure 2-22.

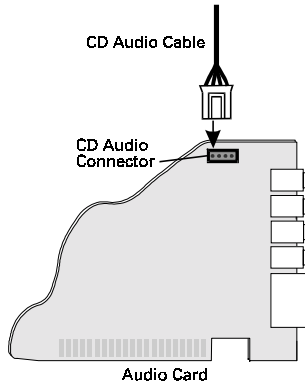

Figure 2-22: Connecting the CD audio cable to the audio card.

5. If you do not have an audio card installed in your system, connect a headphone or powered speakers to the Stereo Phone Jack on your drive's front panel. Set the volume controls of your drive and powered speakers to minimum before powering on (or resetting) the system. This is to prevent possible damage to the headphone or speaker.

- Slide the drives back into place and fasten them to your system as shown in Figure 2-23.

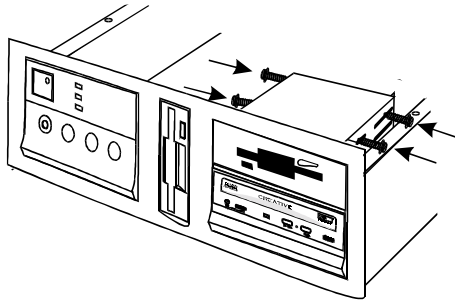

Figure 2-23: Fastening the drives to your system.

- Switch on your system.
- Proceed to install the software.

Installing the Software

The following instructions show you how to install two drivers required to control your CD-ROM drive and an application that allows you to play audio CDs.

To install the software:

- Insert the CD-ROM Installation Disk into drive A or B of your computer.
- Type **A:INSTALL** (or **B:INSTALL**) and press <Enter>.
- Follow the instructions on the screen to complete the installation.



If you are connecting your drive to the hard disk controller card, select 1F0 for the I/O address.

The installation program creates a directory to store the accompanying software. The program adds the following statements to your AUTOEXEC.BAT and CONFIG.SYS files respectively:

AUTOEXEC.BAT:

```
C:\path\MSCDEX /D:MSCD001 /M:8 /V
```

CONFIG.SYS:

```
DEVICE=C:\path\SBIDE.SYS /D:MSCD001 /P:1E8,11 /V
```



If you are connecting your drive to the hard disk controller card, the statement added to your CONFIG.SYS is

```
DEVICE=C:\path\SBIDE.SYS /D:MSCD001 /P:1F0,14 /V
```

For more information on these two statements, refer to the section “Changing the Driver Settings” in Chapter 4. It is important to reboot your system for the changes to take effect. When you reboot, the MSCDEX statement will display the drive letter assigned to your CD-ROM drive.



If you wish to connect your new drive to your existing CD-ROM drive, read the section “Connecting Additional Drives” in Chapter 4. If you wish to replace your current CD-ROM drive with this new drive, remove your drive’s driver settings from the CONFIG.SYS file before you reboot your system. Refer to your DOS manual for more information.

Testing the Installation

After installing the software and rebooting your system, you need to ensure that your CD-ROM drive and drivers are installed properly. Before you test your drive, make sure a pair of speakers are connected to your system. If you do not have an audio card, connect your speakers to the Stereo Phone Jack on your drive’s front panel.

To test that your drive is working properly:

1. Load an audio CD onto your disc tray.
2. Change to the installed directory.
3. Type **TESTCD** and press <Enter>.
4. Follow the instructions on the screen.

TESTCD does the following:

- ❑ Checks that the drive is properly set up.
If you see a MSCDEX error message, check that SBIDE.SYS is properly installed (see the section “Changing the Driver Settings” in Chapter 4). Also, ensure that the data and power cables are properly connected to the CD-ROM drive.
- ❑ Checks that there is audio output.
If there is no audio output, refer to Appendix B.



If your CD-ROM drive and drivers are installed properly, you can replace the cover of your system.

Using QuickCD

QuickCD allows you to play audio CDs in DOS and Windows. Like your CD player, QuickCD is easy and fun to operate.

This chapter provides you with information on:

- Running DOS QuickCD
- Running Windows QuickCD



If you have not installed the software that comes with your audio card, you should install it before proceeding.

Running DOS QuickCD

To run DOS QuickCD:

1. Change to your sound directory.
2. Change to PLAYCD subdirectory.

- At the DOS prompt, type **QCD** and press <Enter>. The QuickCD screen similar to Figure 3-1 appears.

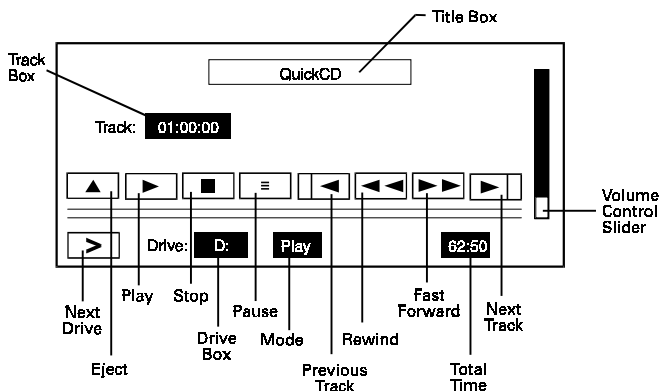

Figure 3-1: The QuickCD screen.



If you have more than one drive, this program allows you to specify the desired drive at the DOS prompt. For example, to play the audio disc from your F drive, type **QCD /D:F** and press <Enter>.

Understanding the DOS QuickCD Screen

DOS QuickCD supports the same features found on a CD player and more. To help you use these features, the following are descriptions of the different buttons and boxes (see Figure 3-1) found on the QuickCD screen:

Eject button	Ejects or closes the tray. This function only applies if your CD-ROM drive has a motorized tray loading system.
Play button	Plays the track shown in the Track box.
Stop button	Stops the track.
Pause/Resume button	Pauses or resumes the track.

Next Track button	Plays the next track. If it is the end of the CD, the first track is played.
Previous Track button	Plays the previous track. If it is the start of the CD, the last track is played.
Fast Forward button	Forwards the current track by 16 seconds. If the end of the last track is encountered, this function is ignored.
Rewind button	Rewinds the current track by 16 seconds. If it is the start of the first track, this function is ignored.
Next Drive button	Changes to the next CD-ROM drive. If there is only one drive, this function is ignored.
Drive box	Displays the current CD-ROM drive.
Mode box	Displays the current operation.
Total Time box	Displays the total time required to play all tracks on the CD.
Volume Control slider	Controls the volume of the CD audio. To increase or decrease the volume, use the up or down arrow key.
Track box	Displays the current track and duration of the track.

Using the Keyboard and Mouse

You can control and select the various features (buttons and boxes) found on the QuickCD screen by using the mouse or the keyboard.



Click on a button to start an operation.

Click the left or right mouse button to increase or decrease the volume, after you have clicked on the Volume Control Slider.



Use the left and right arrow keys to choose a button.

Press <Enter> to start the operation.

Use the up or down arrow key to increase or decrease the volume, after you have selected the Volume Control Slider.

Quitting DOS QuickCD

To quit DOS QuickCD, do one of the following:

- Press <Esc>.
- Click on the Title box.

Running Windows QuickCD

Before you can use Windows QuickCD, you need to

- Set it up in Windows
- Install the MCICDA.DRV driver that comes with your Windows 3.1 package.



MCICDA.DRV is the device driver that allows you to play audio CDs in Windows.

To set up QuickCD in Windows:

1. Click the Accessories group window.
2. Select New from the File menu.

The New Program Object dialog box similar to Figure 3-2 appears.

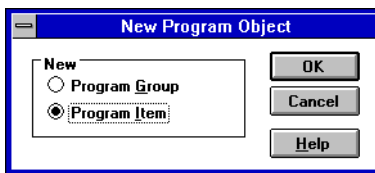

Figure 3-2: The New Program Object dialog box.

3. Select Program Item and choose OK.

The Program Item Properties dialog box similar to Figure 3-3 appears.

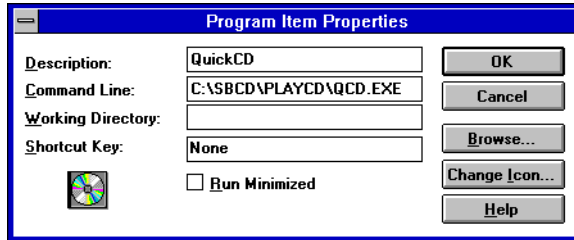

Figure 3-3: The Program Item Properties dialog box.

4. Type in the description as shown in Figure 3-3.

5. Choose OK.

The QuickCD icon appears in the Accessories group window.

To add MCICDA.DRV:



1. Double-click the Control Panel icon in the Main group window.

The Control Panel group window similar to Figure 3-4 appears.

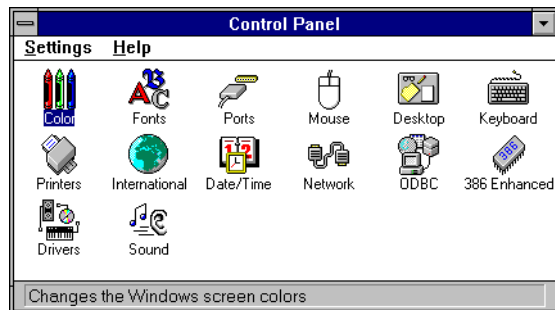

Figure 3-4: The Control Panel group window.



2. Double-click the Drivers icon in the Control Panel group window.

The Drivers dialog box similar to Figure 3-5 appears.

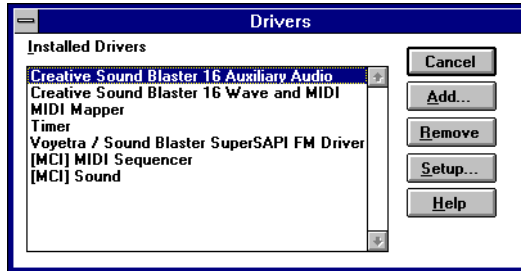

Figure 3-5: The Drivers dialog box.

3. Check that the statement [MCI] CD Audio appears in the Installed Drivers list box.
 - If the statement [MCI] CD Audio appears in the Drivers dialog box, choose Close to exit the Drivers dialog box. You can proceed to run Windows QuickCD.
 - If the statement [MCI] CD Audio does not appear in the Drivers dialog box, follow steps 4, 5, 6, and 7 to add this statement.
4. Choose Add... from the Drivers dialog box. The Add dialog box similar to Figure 3-6 appears.

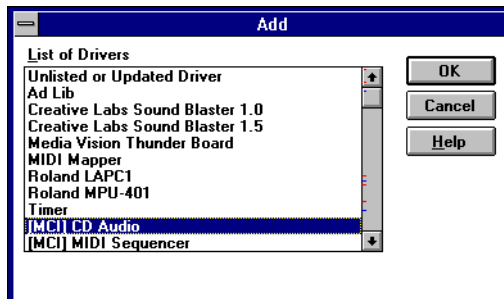

Figure 3-6: The Add dialog box.

5. Select [MCI] CD Audio from the Add dialog box.

6. Choose OK.
7. Restart Windows for the changes to take effect.

Starting Windows QuickCD

After you set up Windows QuickCD, you can run the program from your Accessories group window.

To run Windows QuickCD:



1. Double-click the QuickCD icon in your Accessories group window.

The QuickCD control window similar to Figure 3-7 appears.

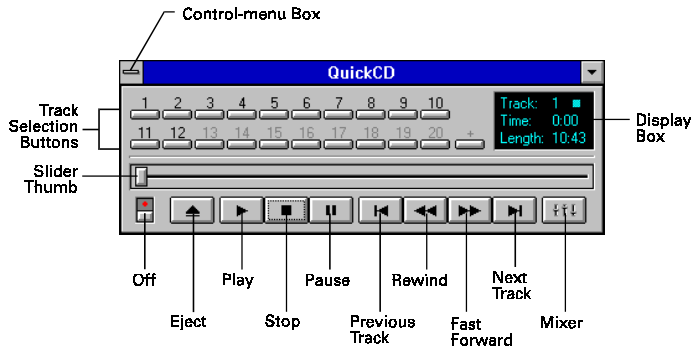



Figure 3-7: The QuickCD control window.

Understanding the Windows QuickCD Control Window

The following describes the buttons, sliders, and display box found on the QuickCD control window:

- | | |
|--------------|--------------------------------------------------------------------------------------------------------------------|
| Off switch | Quits QuickCD. |
| Eject button | Ejects or closes the tray.
This function only applies if your CD-ROM drive has a motorized tray loading system. |

Play button	Plays the track shown in the Display box.
Stop button	Stops the track.
Pause button	Pauses or resumes the track.
Previous Track button	Plays the previous track. If it is the start of the CD, the last track is played.
Rewind button	Rewinds the current track by 10 seconds. If it is the start of the first track, this function is ignored.
Fast Forward button	Forwards the current track by 10 seconds. If the end of the last track is encountered, this function is ignored.
Next Track button	Plays the next track. If it is the end of the CD, the first track is played.
Mixer button	Activates the Mixer.
Slider thumb	Rewinds or forwards the current track.
Track Selection button	Allows you to select the desired track. If there are more than 20 tracks, choose to display  the rest of the tracks.
Display box	Displays the current track and duration of the track.
Control Menu box	Activates the Control menu.

Using the Keyboard and Mouse

You can control and select the various features (buttons and sliders) found on the QuickCD control window by using the mouse or the keyboard.



- Click on the Track Selection button to play a desired track.
- Click on a button to select and start an operation.
- Drag the Slider thumb to forward or rewind the current track.



Press <Tab> to choose a button.

Press <Enter> to start the selected operation.

Move the Slider thumb with the left or right arrow key to forward or rewind the current track.

Using the Control Menu Box

The Control Menu Box (top left corner of the control window) contains commands that allow you to perform various operations such as move, restore, and close the QuickCD control window.

To activate the Control menu:

1. Click on the Control Menu box.
The Control menu similar to Figure 3-8 appears.

Restore	
M ove	
Minimize	
C lose	Alt+F4
S witch To...	Ctrl+Esc
P lay	
S top	
P ause	
S kip	
√ A lways On T op	
P references...	
A bout Q uickCD...	

Figure 3-8: The Control menu.

The following describes the commands found on the menu:

Restore	Restores the QuickCD window from its icon.
Move	Allows you to move QuickCD around the desktop.
Minimize	Reduces QuickCD to an icon.
Close	Quits QuickCD.
Switch To	Opens the Task List dialog box which allows you to select another running application.

Play	Plays the current track.
Stop	Stops the track.
Pause	Pauses or resumes the track.
Skip	Selects the next track and plays it. If it is the end of the CD, the first track is played.
Always on Top	Displays QuickCD on top of the active window.
Preferences	Allows you to customize QuickCD.
About QuickCD	Displays copyright information about QuickCD.

Customizing Windows QuickCD

You can customize Windows QuickCD to work in the way you like. You may wish to automatically play a CD when it is inserted or stop playing every time you exit the application.

To customize Windows QuickCD:

1. Select Preferences from the Control menu.
The Preferences dialog box similar to Figure 3-9 appears.

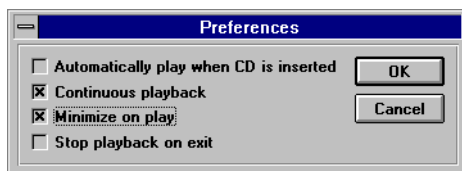

Figure 3-9: The Preferences dialog box.

2. Select the desired options.
 - Automatically play when CD is inserted
Plays an audio CD automatically if it is loaded in the disk tray when you start QuickCD.
 - Continuous playback
Repeats from track 1 after the final track is played.

- Minimize on play
Minimizes QuickCD to an icon when playing audio CD.
 - Stop playback on exit
Stops an audio CD when you exit QuickCD.
3. Choose OK.

Quitting Windows QuickCD

To quit Windows QuickCD, do one of the following:

- Choose the On/Off button.
- Select Close from the Control menu.
- Press <Alt+F4>.

4

Doing More with Your CD-ROM Drive

This chapter comprises several sections to help you get more out of your CD-ROM drive. The chapter is organized as follows:

- ❑ **Changing the Driver Settings**
This section describes the parameters of the drivers that control your CD-ROM drive and the available settings of each driver.
- ❑ **Running CDSETUP**
This section shows you how to run a utility to change your IDE port and IRQ line settings.
- ❑ **Locking the Disc Tray**
You can lock your disc tray if you wish. This section describes two DOS utilities for locking and unlocking the disc tray.
- ❑ **Connecting Additional Drive**
This section shows you how to connect an additional drive to your CD-ROM drive.

Changing the Driver Settings

This section shows you how to change the settings of the two drivers that control your CD-ROM drive.

The two drivers mentioned above are:

- ❑ **SBIDE.SYS**
The hardware-dependent driver for your CD-ROM drive. It enables your CD-ROM drive to communicate effectively with your PC.
- ❑ **MSCDEX.EXE**
The Microsoft CD-ROM Extensions program — the software-dependent driver for your drive. It is a standard

mechanism created by Microsoft to read large files, and it gives your PC the capability to communicate with your CD-ROM drive.

The presence of these two drivers are reflected by the following statements in the CONFIG.SYS and AUTOEXEC.BAT files after you run the installation program.

CONFIG.SYS:

```
DEVICE=C:\path\SBIDE.SYS /D:MSCD001 /P:1E8,11 /V
```

AUTOEXEC.BAT:

```
C:\path\MSCDEX /D:MSCD001 /M:8 /V
```

To help you to edit these parameters correctly, the following sections list the syntax for the SBIDE.SYS and MSCDEX.EXE statements. It also explains the different parameters you can set in each driver.



This section assumes that you know DOS. You should at least be comfortable in changing statements in your AUTOEXEC.BAT and CONFIG.SYS. If you do not know DOS, please ask someone who does to help you.

SBIDE.SYS Settings

SBIDE.SYS supports Primary, Secondary, Tertiary, and Quaternary ports. These ports are industrial conventions for the combination of I/O addresses and IRQ line used by an IDE interface.

The syntax of the SBIDE.SYS statement in CONFIG.SYS is:

```
DEVICE=C:\path\SBIDE.SYS /D:device /P:addr,irq /V
```

The descriptions of the parameters are as follows:

Parameter	Description
<i>path</i>	Specifies the directory where the driver is stored.
<i>/D:device</i>	Specifies the name of the CD-ROM drive. This must be identical to the device name specified by the MSCDEX statement in the AUTOEXEC.BAT file. The installation default setting is MSCD001.
<i>/P:addr,irq</i>	Specifies the base I/O address (<i>addr</i>) in hexadecimal and IRQ line (<i>irq</i>) for the IDE CD-ROM interface on your card. <i>addr</i> can be 1F0, 170, 1E8 (default), or 168. <i>irq</i> can be 10, 11 (default), 12, 14, or 15. See Table 4-1.

Table 4-1: Standard settings for IDE ports.

IDE Port	addr, irq	I/O Addresses Used
Primary	1F0, 14	1F0H to 1F7H, 3F6H to 3F7H
Secondary	170, 15	170H to 177H, 376H to 377H
Tertiary	1E8, 11 or 12	1E8H to 1EFH
Quaternary	168, 10 or 11	168H to 16FH



Select the Primary Port only if you connect your drive to the primary hard disk controller card. Also, you can only connect two IDE devices to each IDE port in a system and the names of these IDE ports do not indicate any kind of sequence for adding IDE devices.

/V Displays the drive type, firmware version, port address, and interrupt of your drive.



You can also run CDSETUP to change the base I/O address and IRQ line of your card. Refer to the section “Running CDSETUP” in this chapter for more information.

MSCDEX.EXE Settings



The syntax of the MSCDEX.EXE statement in AUTOEXEC.BAT is:

```
C:\path\MSCDEX /D:device /M:xx [/L:drive] [/E] /V
```



[] in the above statement refers to any optional parameters. After making changes to the statement, please remember to reboot your system for the changes to take effect.

The descriptions of the parameters are as follows:

Parameter	Description
<i>path</i>	Specifies the directory where the driver is stored.
<i>/D:device</i>	Specifies the name of the CD-ROM drive. Installation default is MSCD001.
<i>/M:xx</i>	Specifies the number of buffers to use for temporary storage of the most recent data. <i>xx</i> ranges from 2 to 32. The performance of your drive increases with the value of <i>xx</i> .  As each buffer uses about 2 KB of memory, specifying too many buffers may interfere with programs that have large memory requirements.
<i>/L:drive</i>	Specifies the drive letter assigned to the first CD-ROM drive. If this is not specified, the next available drive letter is used by your system.  If you have specified the LASTDRIVE statement in your CONFIG.SYS, make sure that the drive letter falls within the specified range. See Appendix C, "Troubleshooting" for more information.
<i>/E</i>	Specifies the use of expanded memory. This parameter is only applicable to Expanded Memory Manager LIM version 3.2 or later.
<i>/V</i>	Displays RAM allocation and expanded memory usage at boot time.

Running CDSETUP

After you have installed your software, you can run CDSETUP to change the base I/O address and IRQ line of your IDE interface.



To change the base I/O address and IRQ line of your card, you need to change the jumper setting on your audio or IDE CD-ROM interface card. Refer to the appendix “Resolving Hardware Conflicts” to change the jumper setting on your IDE CD-ROM interface card. To change the jumper setting on your audio card, refer to the documentation that comes with your audio card.

To run CDSETUP:

1. Change to your installed directory.
2. Type **CDSETUP** and press <Enter>.
3. Follow the instructions on the screen.
4. Restart your system for the changes to take effect.



If you do not wish to run CDSETUP, you can use a text editor to change the base I/O address and IRQ line of your card. Refer to the section “Changing the Driver Settings” in this chapter for more information.

Locking the Disc Tray

If you do not want others to remove your CD from the disc tray, you can lock or unlock the disc tray using the DOS utilities LOCKCD.EXE and UNLOCKCD.EXE. LOCKCD.EXE and UNLOCKCD.EXE allow you to disable and enable the Stop/Eject button respectively.

To lock the disc tray:

1. Change to the installed directory.
2. Type **LOCKCD d1: [d2: d3: d4:]** and press <Enter>.



d1, *d2*, *d3*, and *d4* refer to the drives you want to lock. For example, to lock the disc trays for drives D, E, and F, type **LOCKCD D: E: F:** and press <Enter>.

Once you have locked the tray, it can only be ejected if you run UNLOCKCD.EXE or restart the system.

To unlock the disc tray:

1. Change to the installed directory.
2. Type **UNLOCKCD *d1*: [*d2*: *d3*: *d4*:]** and press <Enter>.



d1, *d2*, *d3*, and *d4* refer to the drives you want to unlock.

Connecting Additional Drives

You can connect additional drives to your system. You can connect two CD-ROM drives to each IDE port. When you connect the drives, you need to assign the drive as the Master or Slave drive. This is done by configuring the Master/Slave Jumper settings at the back of the drive.



Do not connect two CD-ROM drives to the same IDE port if they require different device drivers. The device drivers may not work together.

This section shows you how to:

- Enable and Disable Jumpers
- Configure the Master/Slave Jumper Settings
- Connect Additional Drive to Your Drive



You need a data cable (similar to the one that comes with your package) to connect the drives.

Enabling and Disabling Jumpers

A jumper exists in two states: enabled or disabled. A jumper is enabled when a plastic hood called a jumper block is placed over the jumper's two pins as shown in Figure 4-1.

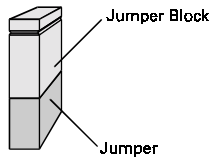

Figure 4-1: An enabled jumper.

In contrast, a disabled jumper is one in which the jumper block is not placed over the jumper's two pins as shown in Figure 4-2.

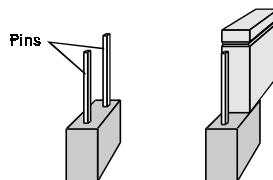

Figure 4-2: Disabled jumpers.

Configuring the Master/Slave Jumper Setting

You can set your drive as the Master or Slave drive using the Master/Slave Jumper at the back of the drive. The factory default is Slave.

The instructions below show you how to connect an additional GCD-R542B to your drive. If your additional drive is not GCD-R542B, refer to the documentation that comes with your drive.

To configure your drive to Master or Slave:

1. Remove the jumper blocks from the Master/Slave Jumper of your drive.

- Set your drive by placing the jumper blocks on the desired jumper as shown in Figure 4-3.

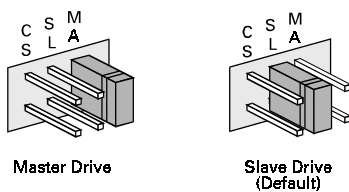

Figure 4-3: The available ID Jumper settings.



The jumper labeled CS is reserved and should not be used.

Connecting the Drives

After you have set your drive as the Master or Slave drive, you can connect it to your existing drive using a daisy-chain cable as shown in Figure 4-4.

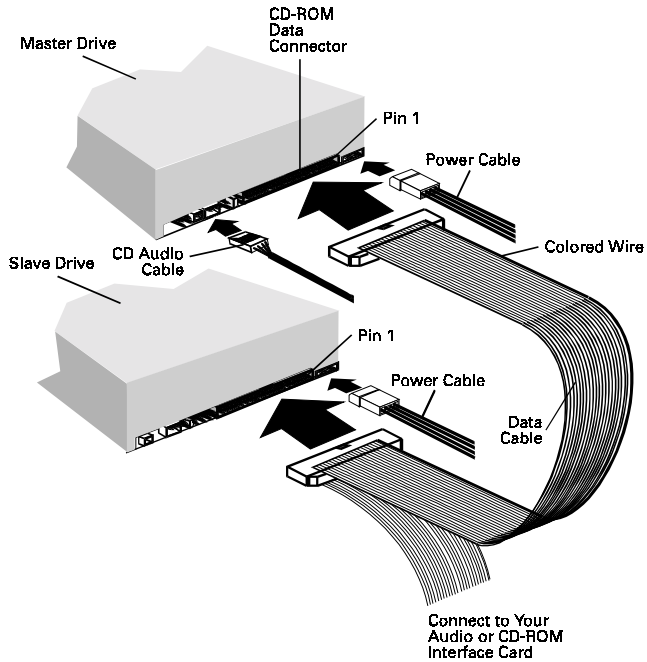

Figure 4-4: Daisy-chaining the drives.



Make sure that you align the colored wire on the data cable to Pin 1 on your CD-ROM drives' IDE CD-ROM Connector, and the CD audio cable to the Master drive.

A

Technical Data

This appendix provides you with the technical specifications of your drive.

Physical Dimensions

Height	41.5 mm
Width	146.0 mm
Depth	189.0 mm
Color	PC white

Performance Characteristics

Buffer Memory	256 KB
Data Transfer Rate	
Single Speed	150 KB/sec
Quad Speed	600 KB/sec
Access Time	
1/3 Stroke	220 msec (Typical)
MTBF (Mean Time between failure)	50,000 POH (10% duty)
Error Rate	
Normal Speed	< 10 ⁻¹⁵ (Mode 1) < 10 ⁻¹² (Mode 2)
Quad Speed	< 10 ⁻¹⁵ (Mode 1) < 10 ⁻¹² (Mode 2)

Power Supply	5 Volts \pm 5% 12 Volts \pm 10%
Current Drain	0.35 Amp (Max.) \pm 5 Volts 0.8 Amp (Max.) \pm 12 Volts

Typical Audio Performance

Frequency Response	20 Hz to 20 kHz \pm 3 dB
Signal to Noise Ratio	85 dB
Total Harmonic Distortion (at 1 kHz)	0.2% (Typical)
Channel Separation	70 dB
Line Output	0.8 V _{rms} (RL:47k Ω) (Typical)
Headphone Output	0.7 V _{rms} (RL:100k Ω) (Typical)

Environmental Operating Limits

Ambient Temperature (No Condensation)

Operating	0 to 40°C
Storage	20 to 60°C

Relative Humidity (No Condensation)

Operating	10 to 60%
Storage	10 to 80%

B

Resolving Hardware Conflicts

This appendix provides you with information on the hardware settings of the IDE CD-ROM interface card. It shows you how to change the Base I/O address and IRQ line if conflicts occur between the IDE CD-ROM interface card and other devices.



To resolve hardware conflicts between your audio card and other devices, read the documentation that comes with your audio card.

I/O Addresses

The interface card's I/O addresses are the addresses used by your computer's microprocessor to distinguish the IDE CD-ROM interface card from other peripheral devices in your system when sending or receiving data. The base I/O addresses and their I/O address ranges are tabulated below.

Table B-1: I/O addresses for IDE port.

IDE Port	Base I/O Address	I/O Address Range
Secondary	170H	170H to 177H, 376H to 377H
Tertiary	1E8H (Default)	1E8H to 1EFH
Quaternary	168H	168H to 16FH

Changing Base I/O Address

If I/O address conflicts occur between the IDE CD-ROM interface card and other devices, you need to change the base I/O address of the IDE CD-ROM interface card or that of the conflicting device.



Change the default base I/O address of the IDE CD-ROM interface card only when another device absolutely requires the I/O addresses assigned to the interface card. If you change the I/O address of your card, you may also need to change the IRQ line. Refer to the section “Changing IRQ Line”.

To change the interface card’s base I/O address:

1. Switch off your system and all peripheral devices.
2. Remove your system’s cover and IDE CD-ROM interface card.

- Place the jumper block on the interface card to select the desired base I/O address as shown in Figure B-1 . A jumper block is a removable plastic hood that fits over a pair of pins.

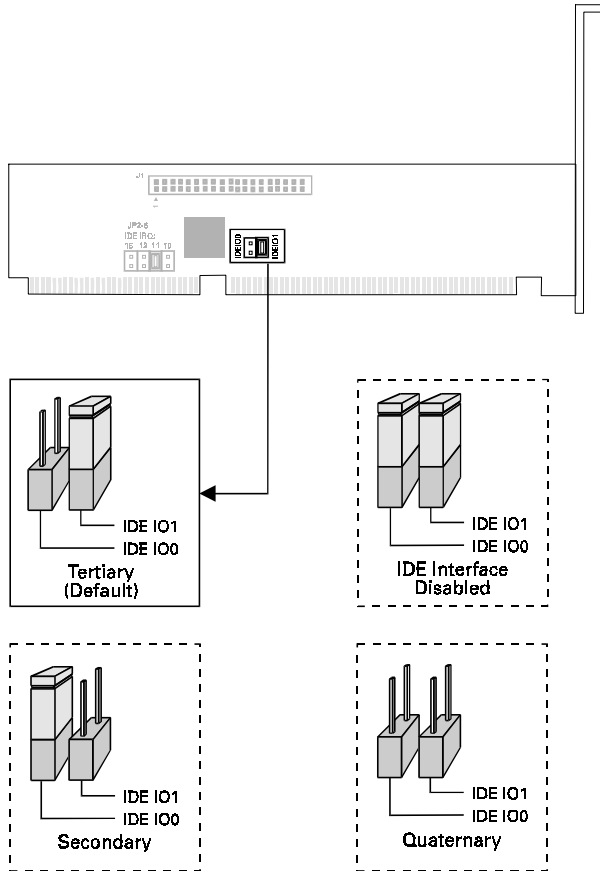

Figure B-1: IDE Port settings for the IDE CD-ROM Interface.

- Run CDSETUP or the installation program to update the setting in your CONFIG.SYS file's SBIDE.SYS statement. For more information on CDSETUP, refer to the section "Running CDSETUP" in Chapter 4.
- Reboot the system for changes to take effect.

Changing IRQ Line

Four IRQ Lines are available for your IDE CD-ROM interface card: 10, 11 (factory default setting), 12 and 15. Refer to Table B-2 for the standard IRQ line assigned to the different IDE port.

Table B-2: IRQ Lines for the respective IDE Port.

IDE Port	IRQ Lines
Secondary	15
Tertiary (Default)	11 (Default) or 12
Quarternary	10 or 11



Refer to the section “Changing Base I/O Address” in this chapter to identify the IDE Port you have specified.

To change the IRQ line, enable the jumpers corresponding to the settings shown in Figure B-2 .

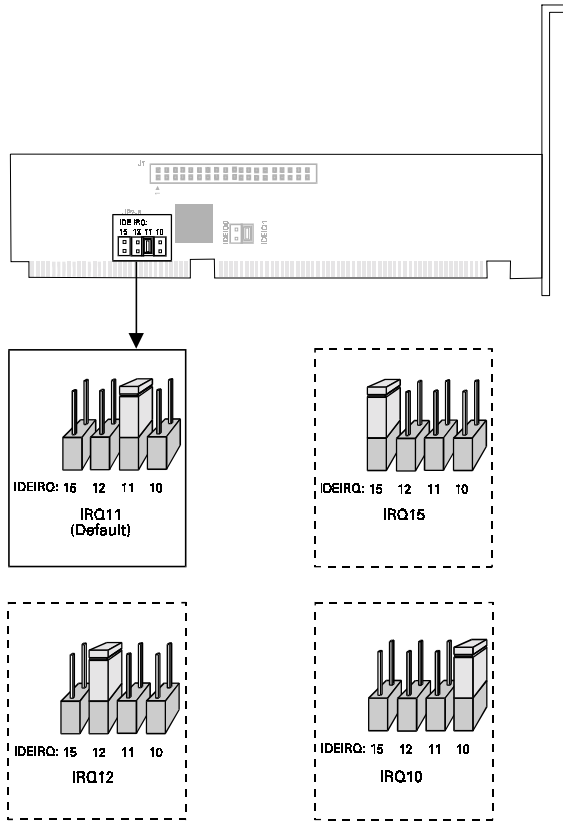

Figure B-2: The available IRQ settings of your IDE CD-ROM Interface.



To ensure that your changes to the IDE CD-ROM interface settings are effected, make corresponding changes to the hardware device driver settings. Refer to the section “Changing the Driver Settings” in Chapter 4 for more information.

C

Troubleshooting

This appendix helps you troubleshoot some common problems you might face.

Problems with CD-ROM Drive

- | | |
|------------------|-------------------------------------------------------------------------------------------------------------------------------------------------------------------------------------------------------------------------------------------------------------------------------------------------------------------------------------------------------------------------------------------------------------------------------------------------------------------------------------------------------------------------------------------------------------------------------------------------------------------------------------------------------------------------------------------------------------------------------------------------------------------------------------------------------------------|
| Problem | No sound from speakers. |
| Causes | <ol style="list-style-type: none">1. Audio cable is not connected properly or the volume is not adjusted to an audible level.2. The drive might be faulty.3. The card might be faulty. |
| Solutions | <ol style="list-style-type: none">1. Check that your speakers are connected to the correct jack on the sound card and the volume is set to mid-range. Check the Mixer to ensure that the volume is set to mid-range. (See the documentation that comes with your audio card for more details.)2. Connect earphones to the Stereo Phone Jack. If there is no sound from your earphones, consult your dealer about your faulty drive.3. Connect earphones to the stereo phone jack. If there is sound from your earphones, check to see the audio cable is connected from the drive to the audio card (see the section “Installing Your Drive” in Chapter 2). If the audio cable is connected and there is no sound from your speakers, consult your dealer about your faulty card. |

- Problem** Interface card or CD-ROM drive is not ready.
- Causes**
1. The power or data cable is not connected.
 2. MSCDEX.EXE or SBIDE.SYS is not loaded.
 3. Some BIOS that include power management features use IRQ 12 or 15.
- Solutions**
1. Ensure the power and CD audio cables are connected properly to the drive (see the section “Installing Your Drive” in Chapter 2).
 2. Your CD-ROM drive requires MSCDEX.EXE and SBIDE.SYS to access the drive. Check your AUTOEXEC.BAT file for the statement
`C:\path\MSCDEX.EXE /D:MSCD001 /M:8 /V`
and CONFIG.SYS file for the statement
`DEVICE=C:\path\SBIDE.SYS /D:MSCD001 /P:1E8,11 /V` (see the section “Changing the Driver Settings” in Chapter 4 for more information).
If you have connected the drive to the hard disk controller card, the statement added to your CONFIG.SYS file is
`DEVICE=C:\path\SBIDE.SYS /D:MSCD001 /P:1F0,14 /V`
 3. Change the IRQ setting of the audio or IDE CD-ROM interface card. Refer to the documentation for more information.

Problem Not enough drive letters available.

Cause You have installed more than 3 logical or physical drives in your system.

Solution Modify the LASTDRIVE statement in your CONFIG.SYS file to reflect the maximum number of drives you can access. For example, if you have installed 5 drives in your system, your current LASTDRIVE statement in your CONFIG.SYS file will be LASTDRIVE=E. Change this statement to LASTDRIVE=F if you want to install an additional drive to your system. See your DOS manual for more details.

Problem I do not know how to specify the settings for the MSCDEX driver when I have two or more CD-ROM drives using different device drivers in my system. For example, I have a Creative IDE and another CD-ROM drive connected to my system.

Solution Modify the MSCDEX statement in your AUTOEXEC.BAT file to include a second device name e.g., MSCD002 (see the following statement).

```
[path]MSCDEX /D:MSCD001 /D:MSCD002 /V /M:8
```

This statement defines the MSCDEX driver for two CD-ROM drives with device names MSCD001 and MSCD002. These device names have to be identical to the device names for the respective CD-ROM device drivers in the CONFIG.SYS file as shown below.

```
DEVICE= [path]SBIDE.SYS /D:MSCD001  
        /P:1E8,11 /V
```

```
DEVICE= [path]xxx.SYS /D:MSCD002
```



SBIDE.SYS is the device driver for Creative IDE CD-ROM drive and xxx.SYS is the device driver for the other CD-ROM drive.

D

Glossary

CD-ROM/XA	CD-ROM Extended Architecture. An extended CD-ROM format developed by Philips, Sony, and Microsoft that allows computer data, compressed audio data, and video/picture data to share a single track.
DAT	Digital Audio Tape. A magnetic tape storage medium for the digital recording and playback of encoded audio information.
Quad Velocity Transfer	Also known as Quad Speed Transfer. The transfer of data from the CD-ROM drive to the microprocessor at 600 KB per second compared to the normal rate of 150 KB per second.
Base I/O Address	The address from which the interface card's I/O addresses begin.
I/O Addresses	The input/output addresses used by your computer's microprocessor to distinguish your CD-ROM drive from other peripherals in your system when sending or receiving data.
Kodak's Photo CD	A disc format and a specialized player developed and marketed by Kodak.
Multimedia	Applications that have been enhanced by the addition of sound, animation, or video. It could also be a combination of all these.

Track

A logical region of a disc. Each track can contain sound, animation, video, or other computer data.

E

Technical Support

We are committed to giving you the best product as well as the best technical support. When you contact us, please have the following information:

- Hardware configuration information such as the base I/O address, IRQ, or DMA channel used.
- Error message on the screen and how it came about.
- Information on the adapter card that conflicts with your card.

This section shows where you can contact us:

- Inside U.S.A., Canada and South America
- Inside Europe
- Inside Asia
- Through Compuserve

Inside U.S.A., Canada and South America

CREATIVE LABS, INC. Technical Support

1523 Cimarron Plaza
Stillwater
OK 74075
U.S.A.

Tel : +405 742 6622
Fax : +405 742 6633
BBS : +405 742 6660

Operating Hours (U.S.A. Central Time)
Mon-Sun : 8:00 am-12:00 am (16 hours)
Public Holidays : Closed

Inside Europe

CREATIVE LABS (IRELAND) LTD. Technical Support

Ballycoolin Business Park
Blanchardstown
Dublin 15
Ireland

Ireland Tel : +353 1 820 7555
 Fax : +353 1 820 5052
 BBS : +353 1 820 3784 (hst)
 : +353 1 820 3818 (Zyxel)

France Tel : +33 1 39 20 04 21
 Fax : +33 1 39 20 90 10
 BBS : +33 1 39 20 90 43 (hst)
 : +33 1 39 20 90 47 (v32bis)
Minitel : 3615 CREATIVE and
 3617 CREATIVE

UK Tel : +44 01734 344 744
 Fax : +44 01734 320 271
 BBS : +44 01743 360 287

Belgium Tel : +32 03 281 35 70
(for Benelux) Fax : +32 03 281 35 80

Germany Tel : +49 089 9579081
(for Central and Fax : +49 089 9577453
Eastern Europe) BBS : +49 089 9557274

Scandinavia Tel : +45 4824 4322
 Fax : +45 4824 4323

Spain Tel : 900 953536 (Freephone)

Operating Hours
Mon-Fri : Business Hours
Sat-Sun : Closed

FaxBack is a facility that allows you to obtain product and technical information through facsimile services. In Europe, use the following number: +353 1 820 3667



Throughout the rest of Europe, please direct all faxes to Ireland.

Inside Asia

CREATIVE TECHNOLOGY LTD. Technical Support

Blk 75, #01-04
Ayer Rajah Crescent
Singapore 0513

Tel : +65 773 4048
Fax : +65 773 0353
BBS : +65 776 2423

Operating Hours (Singapore Time)

Mon-Fri : 9:00 am-6:00 pm
Sat : 9:00 am-1:00 pm
Sun & Public Holidays : Closed

Through Compuserve

To serve you better, we have created a Creative Labs Forum on Compuserve. Through this forum:

- You will have direct access to our company representatives who will be there to answer your questions.
- You will be part of an interactive community of Creative's product users. Here you can share experiences and ideas and also seek solutions to problems.
- We will also keep you up-to-date on the latest product information, software updates, and fixes to common problems.
- We will also welcome your recommendations and suggestions for new products and for improving our products in future releases.

If you are already a member of Compuserve

All you need to do to access the forum is:

- At the Compuserve prompt,
Type **Go Blaster** and press <Enter>.

If you are not a member of Compuserve (valid only in U.S.A.)

We have arranged for you to receive a free introductory Compuserve membership which includes:

- one free month of Compuserve's Basic Services,
- a \$15 introductory usage credit to explore the Creative Forum and Compuserve's other Extended Services,
- a private User ID Number and Password, and
- a complimentary copy of CompuServe Magazine, Compuserve's monthly computing publication.

To receive this special offer:

- Call 1-800-524-3388 and
Ask for Representative #228.

Free Manuals Download Website

<http://myh66.com>

<http://usermanuals.us>

<http://www.somanuals.com>

<http://www.4manuals.cc>

<http://www.manual-lib.com>

<http://www.404manual.com>

<http://www.luxmanual.com>

<http://aubethermostatmanual.com>

Golf course search by state

<http://golfingnear.com>

Email search by domain

<http://emailbydomain.com>

Auto manuals search

<http://auto.somanuals.com>

TV manuals search

<http://tv.somanuals.com>