

8" and 10" Bench Grinders (Models 23-880 & 23-980)

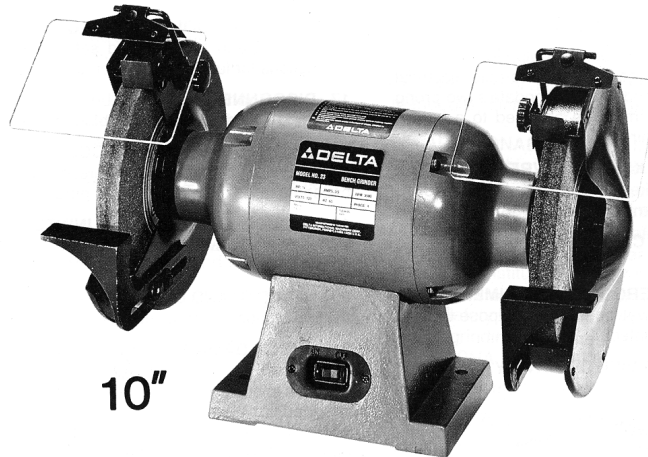

The Serial No. and Model No. plate is attached to the front of the motor. Locate this plate and record the Serial No. and Model No. in your manual for future reference.
SERIAL NO.
MODEL NO.



Dated 8-11-95

PART NO. 1345338
© Delta International Machinery Corp. 1995

 **DELTA**

SAFETY RULES

Woodworking can be dangerous if safe and proper operating procedures are not followed. As with all machinery, there are certain hazards involved with the operation of the product. Using the machine with respect and caution will considerably lessen the possibility of personal injury. However, if normal safety precautions are overlooked or ignored, personal injury to the operator may result. Safety equipment such as guards, push sticks, hold-downs, featherboards, goggles, dust masks and hearing protection can reduce your potential for injury. But even the best guard won't make up for poor judgment, carelessness or inattention. Always use common sense and exercise caution in the workshop. If a procedure feels dangerous, don't try it. Figure out an alternative procedure that feels safer. REMEMBER: Your personal safety is your responsibility.

This machine was designed for certain applications only. Delta Machinery strongly recommends that this machine not be modified and/or used for any application other than that for which it was designed. If you have any questions relative to a particular application, DO NOT use the machine until you have first contacted Delta to determine if it can or should be performed on the product.

DELTA INTERNATIONAL MACHINERY CORP.
MANAGER OF TECHNICAL SERVICES
246 ALPHA DRIVE
PITTSBURGH, PENNSYLVANIA 15238
(IN CANADA: 644 IMPERIAL ROAD, GUELPH, ONTARIO N1H 6M7)

WARNING: FAILURE TO FOLLOW THESE RULES MAY RESULT IN SERIOUS PERSONAL INJURY

1. FOR YOUR OWN SAFETY, READ INSTRUCTION MANUAL BEFORE OPERATING THE TOOL. Learn the tool's application and limitations as well as the specific hazards peculiar to it.

2. KEEP GUARDS IN PLACE and in working order.

3. ALWAYS WEAR EYE PROTECTION.

4. GROUND ALL TOOLS. If tool is equipped with three-prong plug, it should be plugged into a three-hole electrical receptacle. If an adapter is used to accommodate a two-prong receptacle, the adapter lug must be attached to a known ground. Never remove the third prong.

5. REMOVE ADJUSTING KEYS AND WRENCHES. Form habit of checking to see that keys and adjusting wrenches are removed from tool before turning it "on."

6. KEEP WORK AREA CLEAN. Cluttered areas and benches invite accidents.

7. DON'T USE IN DANGEROUS ENVIRONMENT. Don't use power tools in damp or wet locations, or expose them to rain. Keep work area well-lighted.

8. KEEP CHILDREN AND VISITORS AWAY. Children and visitors should be kept a safe distance from work area.

9. MAKE WORKSHOP CHILDPROOF - with padlocks, master switches, or by removing starter keys.

10. DON'T FORCE TOOL. It will do the job better and be safer at the rate for which it was designed.

11. USE RIGHT TOOL. Don't force tool or attachment to do a job for which it was not designed.

12. WEAR PROPER APPAREL. No loose clothing, gloves, neckties, rings, bracelets, or other jewelry to get caught in moving parts. Nonslip footwear is recommended. Wear protective hair covering to contain long hair.

13. ALWAYS USE SAFETY GLASSES. Wear safety glasses (must comply with ANSI Z87.1). Everyday eyeglasses only have impact resistant lenses; they are not safety glasses. Also use face or dust mask if cutting operation is dusty.

14. SECURE WORK. Use clamps or a vise to hold work when practical. It's safer than using your hand and frees both hands to operate tool.

15. DON'T OVERREACH. Keep proper footing and balance at all times.

16. MAINTAIN TOOLS IN TOP CONDITION. Keep tools sharp and clean for best and safest performance. Follow instructions for lubricating and changing accessories.

17. DISCONNECT TOOLS before servicing and when changing accessories such as blades, bits, cutters, etc.

18. USE RECOMMENDED ACCESSORIES. The use of accessories and attachments not recommended by Delta may cause hazards or risk of injury to persons.

19. REDUCE THE RISK OF UNINTENTIONAL STARTING. Make sure switch is in "OFF" position before plugging in power cord.

20. NEVER STAND ON TOOL. Serious injury could occur if the tool is tipped or if the cutting tool is accidentally contacted.

21. CHECK DAMAGED PARTS. Before further use of the tool, a guard or other part that is damaged should be carefully checked to ensure that it will operate properly and perform its intended function - check for alignment of moving parts, binding of moving parts, breakage of parts, mounting, and any other conditions that may affect its operation. A guard or other part that is damaged should be properly repaired or replaced.

22. DIRECTION OF FEED. Feed work into a blade or cutter against the direction of rotation of the blade or cutter only.

23. NEVER LEAVE TOOL RUNNING UNATTENDED. TURN POWER OFF. Don't leave tool until it comes to a complete stop.

24. DRUGS, ALCOHOL, MEDICATION. Do not operate tool while under the influence of drugs, alcohol or any medication.

25. MAKE SURE TOOL IS DISCONNECTED FROM POWER SUPPLY while motor is being mounted, connected or reconnected.

ADDITIONAL SAFETY RULES FOR GRINDERS

1. **WARNING:** Do not operate your grinder until it is completely assembled and installed according to the instructions.
2. **IF YOU ARE NOT** thoroughly familiar with the operation of grinders, obtain advice from your supervisor, instructor or other qualified person.
3. **ALWAYS** use grinding wheels that have a bore exactly equal to the arbor of the grinder. **NEVER** attempt to machine an undersize wheel to fit an arbor.
4. **NEVER** use a chipped or cracked grinding wheel. **ALWAYS** inspect each wheel before mounting on the grinder. Replace a cracked wheel immediately.
5. **ALWAYS** maintain a distance of 1/8" or less between the grinding wheel and the tool rest. Adjust the tool rests as the grinding wheels decrease in size with use.
6. **SECURELY** tighten tool rests so they cannot shift position while in use.
7. **NEVER** grind on a cold wheel. The grinder should always be started and run at idle speed for one full minute before applying work.
8. **NEVER** grind on the side of the wheel. **ALWAYS** grind on the face of the wheel only.
9. **NEVER** apply coolant directly to a grinding wheel. Coolant can weaken the bonding strength of the wheel and cause it to fail. Dip the workpiece into water to cool it.
10. **SPARKS ARE A HAZARD!** **NEVER** grind near flammable gas or liquids.
11. **ALWAYS MAKE SURE** the wheel guards and eye shields are in place, properly adjusted and secured.
12. **KEEP** the spark guards close to the wheel and re-adjust them as the wheel wears.
13. **MAKE CERTAIN** the blotter and wheel flanges are used to mount the grinding wheels onto the grinder shaft.
14. **STAND** to one side of the wheel when turning on the power.
15. **AVOID** awkward hand positions where a sudden slip could cause a hand to move into the grinding wheel.
16. **ALWAYS** keep hands and fingers away from the grinding wheel.
17. **NEVER** start the grinder with the workpiece pressed against the grinding wheel.
18. **DRESS** the wheel on the face only. Dressing the side of the wheel can cause it to become too thin for safe use.
19. **DO NOT** use a wheel that vibrates. Dress the wheel, replace the wheel, or replace the shaft bearings, if worn.
20. **GRINDING CREATES HEAT.** Do not touch the workpiece until you are sure it has cooled sufficiently.
21. **ALWAYS** use grinding wheels that are suitable for the speed of the grinder. **NEVER** use a wheel that is rated lower than the grinder speed.
22. **ALWAYS** keep guards in place when using a wire brush or buffing wheel in place of the standard grinding wheel.
23. **SHOULD** any part of your grinder be missing, damaged, or fail in any way, or any electrical component fail to perform properly, shut off switch and remove plug from power supply outlet. Replace missing, damaged or failed parts before resuming operation.
24. **THE USE** of attachments and accessories not recommended by Delta may result in the risk of injuries.
25. **ADDITIONAL** information regarding the safe and proper operation of this product is available from the National Safety Council, 1121 Spring Lake Drive, Itasca, IL 60143-3201 in the Accident Prevention Manual for Industrial Operations and also in the Safety Data Sheets provided by the NSC. Please also refer to the American National Standards Institute ANSI B7.1 Safety Requirements for the use, care, and protection of abrasive wheels; ANSI B11.9 Safety Requirements for the construction, care and use of grinding machines; and the U.S. Department of Labor OSHA 1910.215 Regulations for Abrasive Wheel Machinery.
26. **SAVE THESE INSTRUCTIONS.** Refer to them often and use them to instruct others.

UNPACKING AND CLEANING

Your new grinder is shipped complete in one carton. Carefully unpack the grinder and all loose items from the carton.

WARNING: FOR YOUR OWN SAFETY, DO NOT CONNECT THE GRINDER TO THE POWER SOURCE UNTIL THE MACHINE IS COMPLETELY ASSEMBLED AND YOU HAVE READ AND UNDERSTAND THE ENTIRE INSTRUCTION MANUAL.

ASSEMBLY INSTRUCTIONS

ASSEMBLING TOOL RESTS

1. Assemble adjustable tool rest (A) Fig. 1, to left side of tool rest arm (B), as shown, and fasten with one 3/4 inch-long hex head screw and lockwasher (C). Assemble the remaining tool rest to the right side of the other tool rest arm in the same manner. Do not completely tighten hardware at this time.
2. Assemble left tool rest assembly (D) Fig. 2, to the inside of left wheel guard (E), and fasten with two 5/8 inch-long screws and flat washers (F) as shown.
3. Assemble right tool rest assembly to the inside of right wheel guard and fasten with two 3/4 inch-long hex head screws and flat washers.
4. Each tool rest assembly (D) Fig. 2, is adjustable so it can be positioned slightly below the centerline of the wheel and as close to the grinding wheel as possible, giving maximum support to the piece that is being ground. A distance of 1/8-inch or less between the grinding wheel and the inside edge of the tool rest should always be maintained. When the tool rest is positioned correctly, tighten hardware (C) and (F). As the grinding wheel wears down to a smaller diameter, re-adjust the tool rest closer to the wheel. Freehand grinding without the use of a tool rest should always be done on the lower quarter of the wheel.

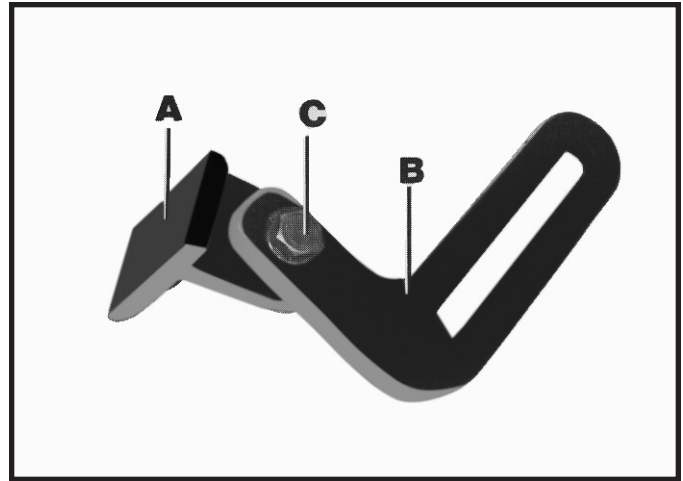

Fig. 1

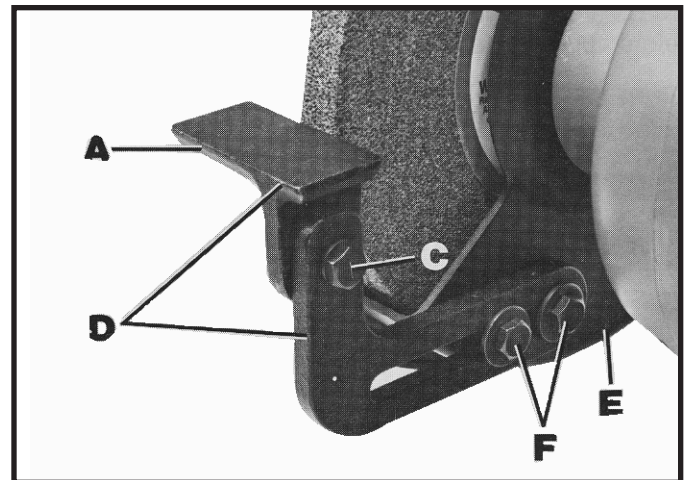

Fig. 2

ASSEMBLING SPARK GUARDS

The spark guard (A) Fig. 3, is to be mounted to the side of each wheel guard, using the 1/4 inch-long screw (B) and washer (C) as shown. The spark guard (A) should be adjusted as close as possible to the grinding wheel so that sparks never strike the operator's hand. As the wheels wear down the spark guard (A) should be adjusted accordingly.

ASSEMBLING EYE SHIELDS

Your grinder is supplied with two safety eye shields for operator protection. To assemble the eye shields, proceed as follows:

1. Place shield (A) Fig. 4, under the lip of frame (B). Line up the two holes in the shield with the two holes in the frame and fasten together using two 1/2 inch-long, round head screws (C), washers (D) and nuts (E). Assemble the other shield in the same manner.

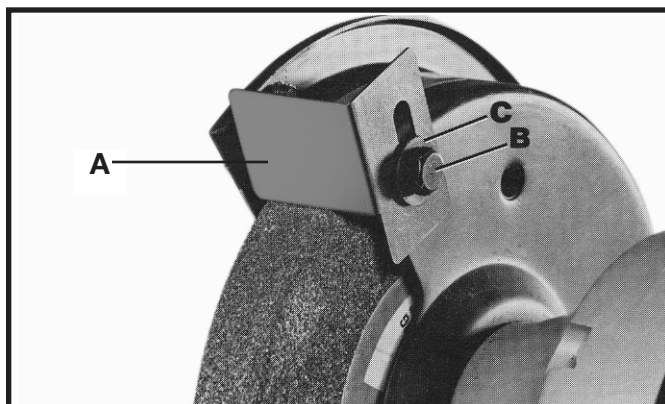

Fig. 3

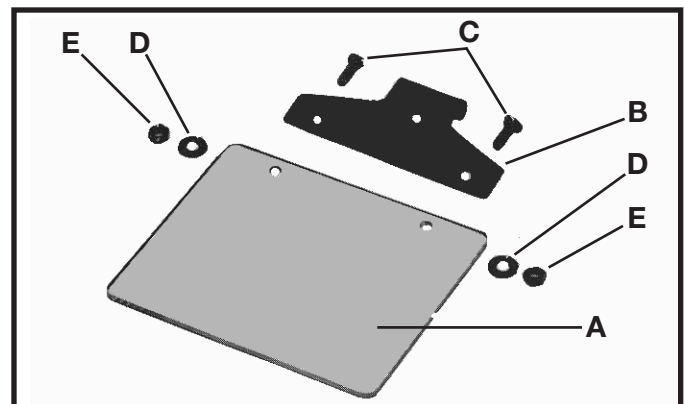

Fig. 4

2. Insert the short end of mounting rod (F) Fig. 5, into hole of frame (B) and fasten in place with 3/4 inch-long square necked round head screw (G) and nut (H).

3. Assemble long end of eye shield mounting rod (F) Fig. 6, to the side of each wheel guard using bracket (J), lockwasher and locking knob (L). The eye shield (A) is fully adjustable so it can be put in any position by moving the shield (A) or loosening locking knob (L) and repositioning rod (F).

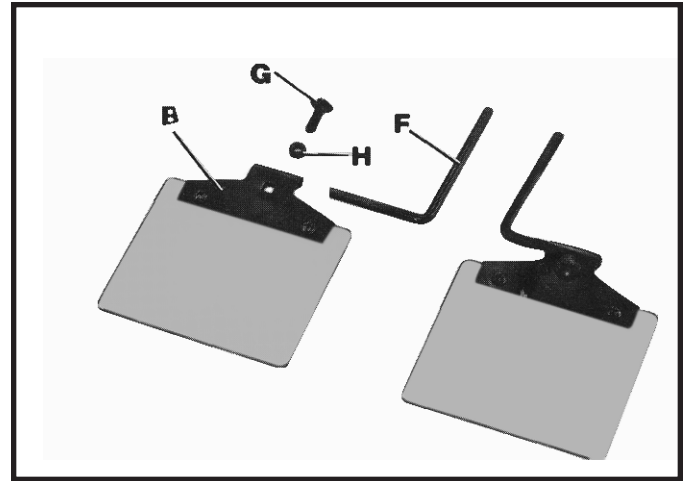

Fig. 5

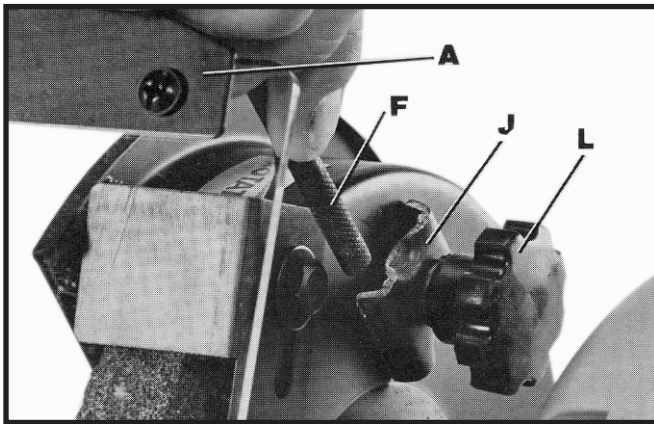

Fig. 6

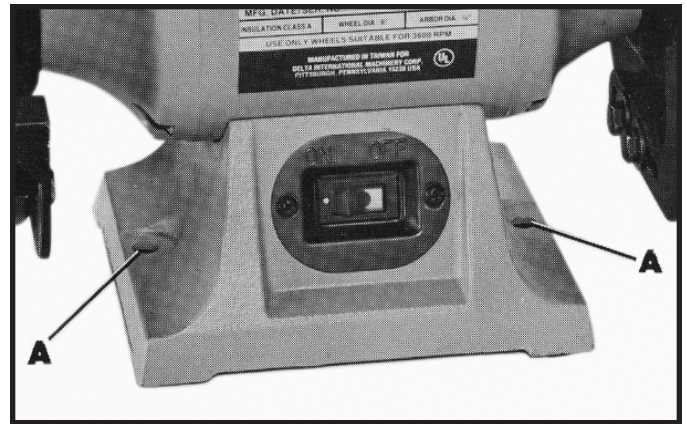

Fig. 7

CONNECTING GRINDER TO POWER SOURCE

POWER CONNECTIONS

A separate electrical circuit should be used for your tools. This circuit should not be less than #12 wire and should be protected with a 20 Amp fuse. Have a certified electrician replace or repair a worn cord immediately. Before connecting the motor to a power line, make sure the switch is in the "OFF" position and be sure that the electric current is of the same characteristics as stamped on the motor nameplate. Running on low voltage will damage the motor.

WARNING: DO NOT EXPOSE THE TOOL TO RAIN OR OPERATE THE TOOL IN DAMP LOCATIONS.

MOTOR SPECIFICATIONS

Your grinder is wired for 110-120 volt, 60 HZ alternating current. Before connecting the grinder to the power source, make sure the switch is in the "OFF" position.

EXTENSION CORDS

Use proper extension cords. Make sure your extension cord is in good condition and is a 3-wire extension cord which has a 3-prong grounding type plug and a 3-pole receptacle which will accept the tool's plug. When using an extension cord, be sure to use one heavy enough to carry the current of the grinder. An undersized cord will cause a drop in line voltage, resulting in loss of power and over-heating. Fig. 7A shows the correct gage to use depending on the cord length. If in doubt, use the next heavier gage. The smaller the gage number, the heavier the cord.

TOTAL LENGTH OF CORD IN FEET		GAGE OF EXTENSION CORD TO USE
0 -	25	18 AWG
26 -	50	16 AWG
51 -	100	14 AWG
101 -	150	12 AWG

Fig. 7A

GROUNDING INSTRUCTIONS

CAUTION: THIS TOOL MUST BE GROUNDED WHILE IN USE TO PROTECT THE OPERATOR FROM ELECTRIC SHOCK.

In the event of a malfunction or breakdown, grounding provides a path of least resistance for electric current to reduce the risk of electric shock. This tool is equipped with an electric cord having an equipment-grounding conductor and a grounding plug. The plug must be plugged into a matching outlet that is properly installed and grounded in accordance with all local codes and ordinances.

Do not modify the plug provided - if it will not fit the outlet, have the proper outlet installed by a qualified electrician.

Improper connection of the equipment-grounding conductor can result in risk of electric shock. The conductor with insulation having an outer surface that is green with or without yellow stripes is the equipment-grounding conductor. If repair or replacement of the electric cord or plug is necessary, do not connect the equipment grounding conductor to a live terminal.

Check with a qualified electrician or service personnel if the grounding instructions are not completely understood, or if in doubt as to whether the tool is properly grounded.

Use only 3-wire extension cords that have 3-prong grounding type plugs and 3-hole receptacles that accept the tool's plug, as shown in Fig. 8.

Repair or replace damaged or worn cord immediately. This tool is intended for use on a circuit that has an outlet and a plug that looks like the one shown in Fig. 8. A temporary adapter, which looks like the adapter illustrated in Fig. 9, may be used to connect this plug to a 2-pole receptacle, as shown in Fig. 9, if a properly grounded outlet is not available. The temporary adapter should

be used only until a properly grounded outlet can be installed by a qualified electrician. THIS ADAPTER IS NOT APPLICABLE IN CANADA. The green-colored rigid ear, lug, and the like, extending from the adapter must be connected to a permanent ground, such as a properly grounded outlet box, as shown in Fig. 9.

CAUTION: IN ALL CASES, MAKE CERTAIN THE RECEPTACLE IN QUESTION IS PROPERLY GROUNDED. IF YOU ARE NOT SURE, HAVE A CERTIFIED ELECTRICIAN CHECK THE RECEPTACLE.

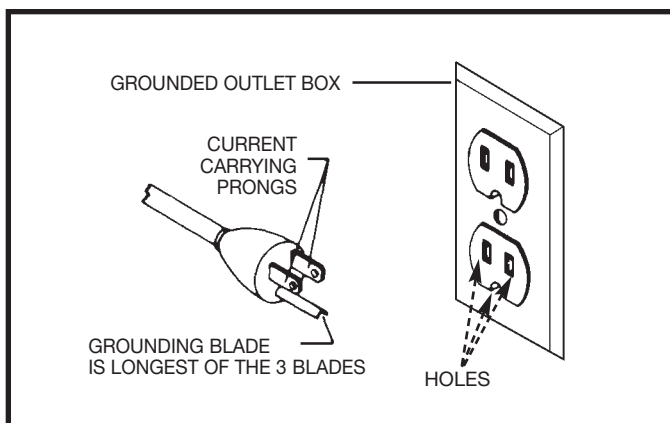

Fig. 8

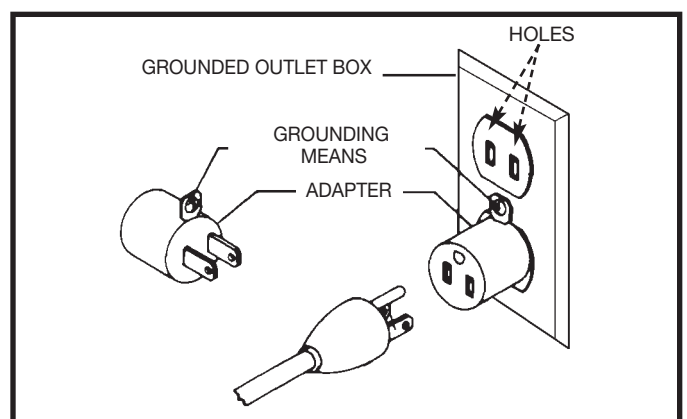

Fig. 9

STARTING AND STOPPING GRINDER

The switch (A) Fig. 10, is located on the front of the grinder. To turn the grinder "ON" push the left hand portion of the switch and to turn the grinder "OFF" push the right hand portion of the switch.

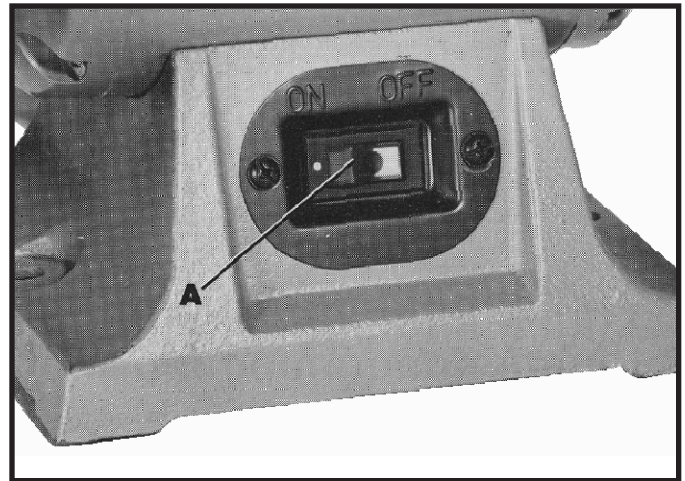

Fig. 10

DRESSING A GRINDING WHEEL

When dressing a grinding wheel use a suitable silicon carbide stick type dresser, as shown in Fig. 11. Bring the dresser forward on the tool rest until it just touches the high point of the face of the wheel and dress the wheel by moving the dresser back and forth. Repeat this operation until the face of the wheel is clean and the corners of the wheel are square.

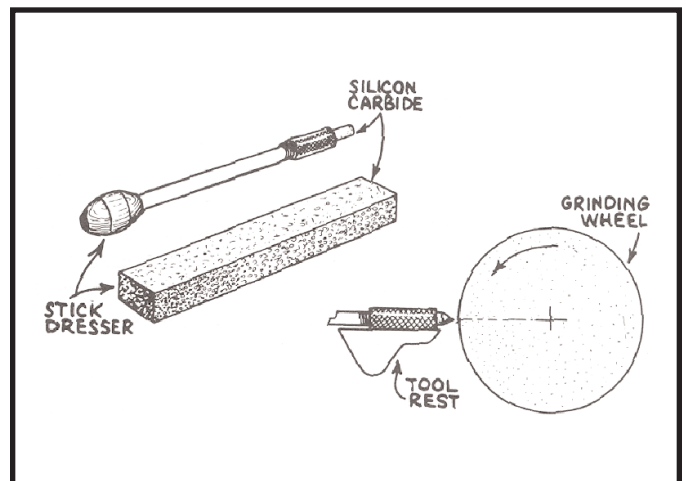

Fig. 11

GRINDING WHEELS

Use only grinding wheels that are rated higher than the no-load speed of grinders. **IMPORTANT:** The 8" grinder has a no-load speed of 3600 RPM; the 10" grinder has a no-load speed of 1800 RPM. Use only grinding wheels that have a bore equal to the diameter of the arbor shaft on the grinder. The 8" grinder is supplied with a 5/8" diameter arbor and the 10" grinder has a 1" diameter arbor.

Two aluminum oxide grinding wheels are supplied with your grinder; one 36 grit and one 60 grit. For best grinding results, and to maintain good balance, always keep the wheels properly dressed. Do not force the work against a cold wheel. The grinding wheel should always be run at idle speed for one full minute before applying work. It is recommended that only balanced wheels be used with your grinder. The use of balanced wheels adds years to the life of the bearings on the grinder and by eliminating the most common source of vibration, more accurate work is accomplished.

CHANGING WHEELS

When changing wheels, simply remove the screws attaching the side covers to the grinder and remove the side cover. To prevent shaft rotation, place a wedge between the grinding wheel and the wheel guard. Facing the grinder, turn the arbor nut down to loosen and up to tighten. **IMPORTANT: DO NOT OVERTIGHTEN WHEEL NUTS WHEN INSTALLING THE WHEELS.**



Delta Building Trades and Home Shop Machinery Two Year Limited Warranty

Delta will repair or replace, at its expense and at its option, any Delta machine, machine part, or machine accessory which in normal use has proven to be defective in workmanship or material, provided that the customer returns the product prepaid to a Delta factory service center or authorized service station with proof of purchase of the product within two years and provides Delta with reasonable opportunity to verify the alleged defect by inspection. Delta may require that electric motors be returned prepaid to a motor manufacturer's authorized station for inspection and repair or replacement. Delta will not be responsible for any asserted defect which has resulted from normal wear, misuse, abuse or repair or alteration made or specifically authorized by anyone other than an authorized Delta Service facility or representative. Under no circumstances will Delta be liable for incidental or consequential damages resulting from defective products. This warranty is Delta's sole warranty and sets forth the customer's exclusive remedy, with respect to defective products; all other warranties, express or implied, whether of merchantability, fitness for purpose, or otherwise, are expressly disclaimed by Delta.

Free Manuals Download Website

<http://myh66.com>

<http://usermanuals.us>

<http://www.somanuals.com>

<http://www.4manuals.cc>

<http://www.manual-lib.com>

<http://www.404manual.com>

<http://www.luxmanual.com>

<http://aubethermostatmanual.com>

Golf course search by state

<http://golfingnear.com>

Email search by domain

<http://emailbydomain.com>

Auto manuals search

<http://auto.somanuals.com>

TV manuals search

<http://tv.somanuals.com>