

50S & 50D

Thermometer

Calibration Information

⚠ Warning

These service instructions are for use by qualified personnel only. To avoid electric shock, do not perform any servicing unless you are qualified to do so.

Introduction

This document contains specifications, general maintenance information, performance tests, calibration procedures, and a list of user replaceable parts for the Fluke 50S and 50D Thermometers, hereafter referred to as “the thermometer”.

Service

To contact Fluke, order parts, or locate a Fluke service center, call one of the following telephone numbers:

USA: 1-888-99-FLUKE (1-888-993-5853)

Canada: 1-800-36-FLUKE (1-800-363-5853)

Europe: +31 402-675-200

Japan: +81-3-3434-0181

Singapore: +65-738-5655

Anywhere in the world: +1-425-446-5500

Or, visit Fluke's Web site at www.fluke.com.

Warranty

This Fluke product will be free from defects in material and workmanship for one year from the date of purchase. This warranty does not cover fuses, disposable batteries or damage from accident, neglect, misuse or abnormal conditions of operation or handling. Resellers are not authorized to extend any other warranty on Fluke's behalf. To obtain service during the warranty period, send your defective tester to the nearest Fluke Authorized Service Center with a description of the problem.

THIS WARRANTY IS YOUR ONLY REMEDY. NO OTHER WARRANTIES, SUCH AS FITNESS FOR A PARTICULAR PURPOSE, ARE EXPRESSED OR IMPLIED. FLUKE IS NOT LIABLE FOR ANY SPECIAL, INDIRECT, INCIDENTAL OR CONSEQUENTIAL DAMAGES OR LOSSES, ARISING FROM ANY CAUSE OR THEORY. Since some states or countries do not allow the exclusion or limitation of an implied warranty or of incidental or consequential damages, this limitation of liability may not apply to you.

Fluke Corporation
P.O. Box 9090
Everett WA
98206-9090

Fluke Europe B.V.
P.O. Box 1186
5602 B.D.
Eindhoven
The Netherlands

PN 1281009

October 1999 Rev.1, 3/03





©1999-2003 Fluke Corporation. All rights reserved. Printed in U.S.A.

All product names are trademarks of their respective companies.

International Symbols

Table 1 identifies the international electrical symbols used in this document.

Table 1. International Electrical Symbols Used in this Document

	Low Battery		Important information
	Complies with relevant Canadian Standards Association directives		Complies with European Union directives
	Underwriters Laboratories, Inc.		

Precautions and Safety Information

Use the thermometer only in the ways specified in the *50S & 50D Users Manual*, part number 1278540.

In this manual, a **Warning** statement identifies conditions and actions that pose a hazard to the user; a **Caution** statement identifies conditions and actions that may damage the thermometer or the test instruments.

Safety Information

Warning

To avoid electrical shock or personal injury, follow these guidelines:

- Before using the thermometer, inspect the case. Do not use the thermometer if it appears damaged. Look for cracks or missing plastic. Pay particular attention to the insulation around the connectors.
- Disconnect the thermocouple(s) from the thermometer before opening the case.
- Replace the battery as soon as the low battery indicator () appears. The possibility of false readings can lead to personal injury.
- Do not use the thermometer if it operates abnormally. Protection may be impaired. When in doubt, have the thermometer serviced.
- Do not operate the thermometer around explosive gas, vapor, or dust.
- Do not apply more than the rated voltage, as marked on the thermometer, between the thermocouple(s), or between any thermocouple and earth ground.
- When servicing the thermometer, use only specified replacement parts.
- Do not use the thermometer with any part of the case or cover removed.

Caution

To avoid damaging the thermometer or the equipment under test:

- Use the proper thermocouples, function, and range for your thermometer.
- Do not attempt to recharge the battery.
- To prevent explosion, do not dispose of battery in fire.
- Follow local laws or regulations when disposing of battery.

Specifications

General

Weight	280 g (10 oz)
Dimensions (without holster)	2.8 cm × 7.5 cm × 16.6 cm (1.1 in × 3 in × 6.6 in)
Battery	Standard 9 V battery (NEDA 1604, 6F22, or 006P)
Protection	Class III as defined in IEC 348, Safety Requirements for Electronic Apparatus

Environmental

Operating Temperature	0 °C to +50 °C (+32 °F to +122 °F)
Storage Temperature	−40 °C to +60 °C (−40 °F to +140 °F)
Humidity	0 % to 90 %: 0 °C to 35 °C (+32 °F to +95 °F) 0 % to 70 %: 0 °C to 50 °C (+32 °F to +122 °F)

Electrical

Measurement Range	K-type: −200 °C to +1370 °C (−328 °F to +2498 °F) J-type: −200 °C to +760 °C (−328 °F to +1400 °F)
Display Resolution	Low: +1.0 °C or +1.0 °F High: +0.1 °C or +0.2 °F
Measurement Accuracy	K-type: ±(0.1 % of reading + 0.7 °C) [±(0.1 % of reading + 1.3 °F)] J-type: ±(0.1 % of reading + 0.8 °C) [±(0.1 % of reading + 1.4 °F)]
Temperature Coefficient	0.01 % of reading + 0.03 °C (0.03 °F) for [ambient temperatures from +18 °C to +28 °C (+64 °F to +82 °F)]
Maximum Differential Common Mode Voltage	1 V (Maximum voltage difference between T1 and T2)
Temperature Scale	IPTS-68
Certification	CE, 
Applicable Standards	NBS 125, IEC 584
Accuracy is specified for ambient temperatures between +18 °C (+64 °F) and +28 °C (+82 °F) for a period of 1 year. The above specifications do not include thermocouple error.	
Accuracy is unspecified when the input lead length is resonant with the interfering frequency.	

Basic Maintenance

Basic maintenance required by the thermometer is discussed in this section.

Cleaning the Thermometer

Caution

- **To avoid damaging the thermometer, do not use aromatic hydrocarbons or chlorinated solvents for cleaning. These solutions react with the plastics used in the thermometer.**
- **Do not allow the LCD to get wet.**
- **Do not remove any of the lubricant from the input terminals.**

Clean the thermometer case with a mild detergent and water.

The pca may be washed with isopropyl alcohol or deionized water and a soft brush. Dry the pca with clean dry air at low pressure, then bake it at 50 °C for 24 hours.

Disassembly/Reassembly

Thermometer disassembly is necessary to replace the battery and some interior parts (see “Replaceable Parts”, later in this document). Refer to Figure 1 when disassembling and reassembling the thermometer.

To disassemble the thermometer:

1. Turn the thermometer OFF if necessary.
2. Loosen the four bottom case screws and remove the top case.

To reassemble the thermometer:

1. Replace the top case.
2. Tighten the four bottom case screws.

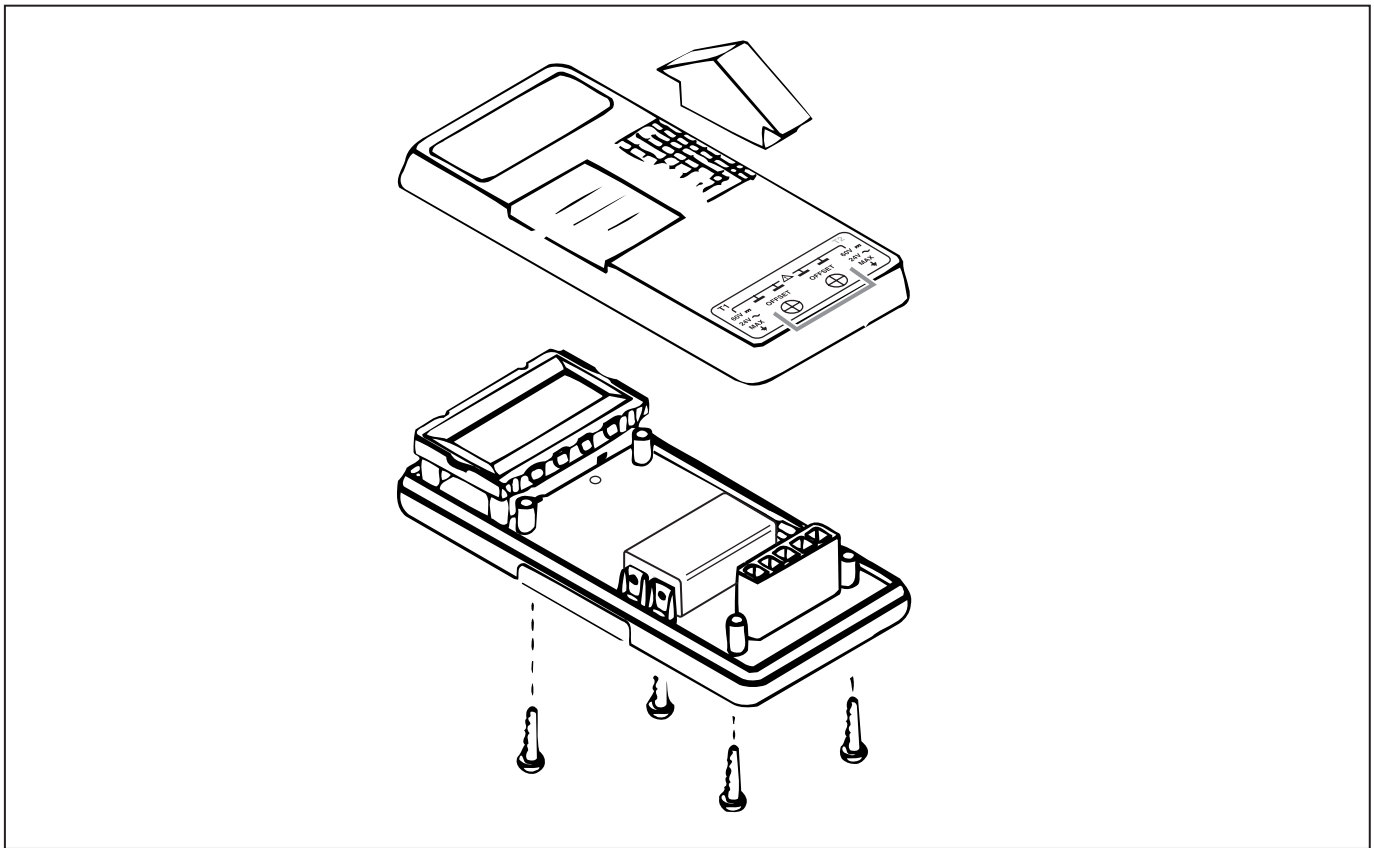

Figure 1. Thermometer Disassembly and Reassembly (50D is shown)

zf01f.eps

Changing the Battery

⚠ Warning

- Replace the battery as soon as the low battery indicator (⎓) appears. The possibility of false readings increases when the battery is not fully charged. False readings can lead to personal injury.
- To avoid electrical shock, disconnect the thermocouple(s) before opening the case.

Caution

- Do not attempt to recharge the battery.
- To prevent explosion, do not dispose of the battery in fire.
- Follow local laws or regulations when disposing of batteries.

To replace the battery, refer to Figure 2 and the assembly procedures located previously in this document.

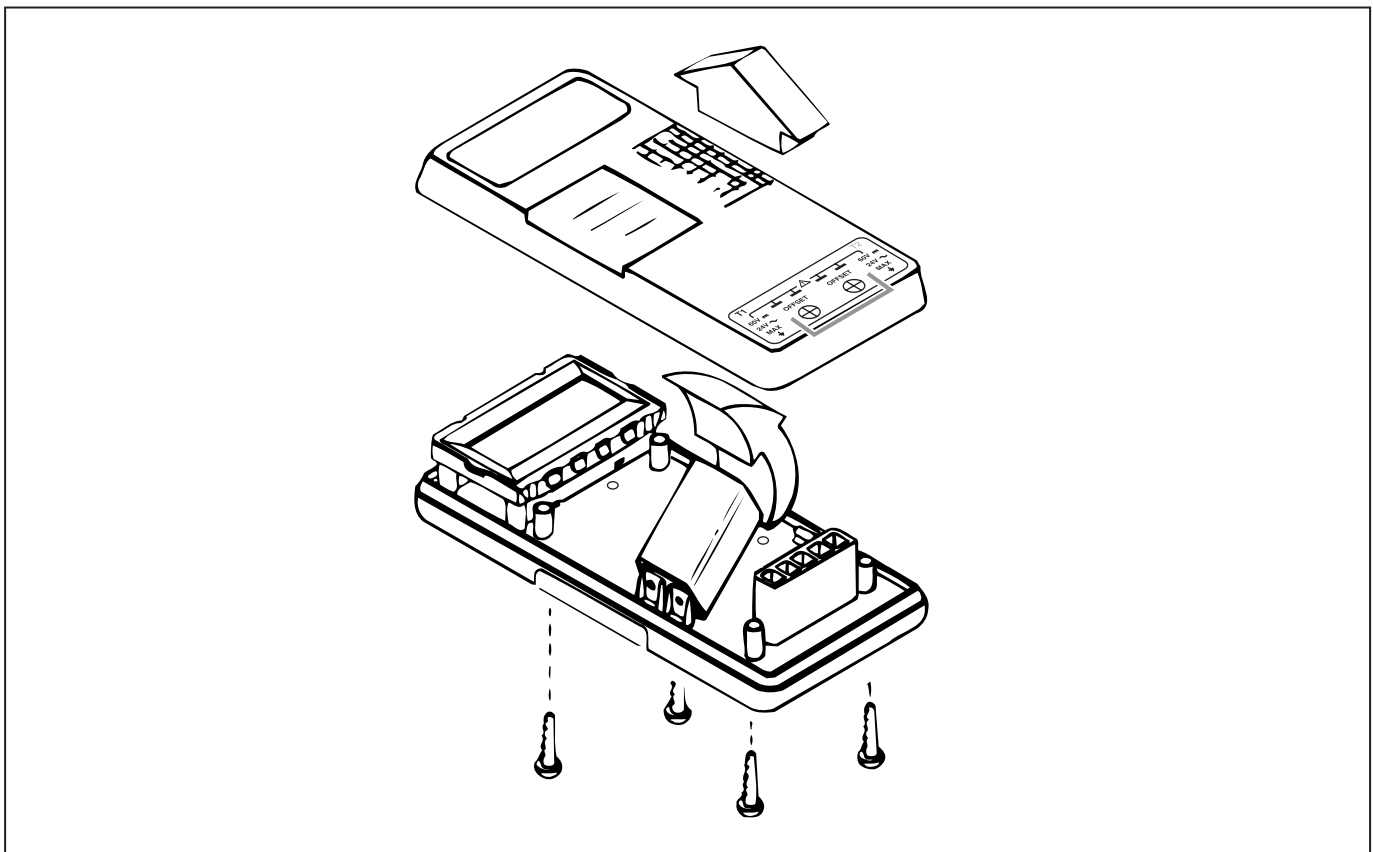

Figure 2. Replacing the Battery (50D is shown)

z102f.eps

Required Test Equipment

Table 2 lists the required test equipment needed to perform the performance test and calibration procedures for the 50S and 50D thermometers. If the required equipment is not available, instruments with equivalent specifications may be used.

Table 2. Required Test Equipment

Test Equipment	Required Characteristics	Recommended Model
DMM	DC Voltage Accuracy: 0.5%	Fluke 87 Series IV Digital Multimeter
Temperature Probe	Accuracy: Certified to ± 0.2 °C ambient	Fluke Model 80T-150U
DC Voltage Calibrator	Output Voltage 0 to 10 V Accuracy: 0.025% Resolution: 10 μ V	Fluke 5520A
Elastomeric Switch Pad		Fluke Part Number 680686
Thermocouple Connector	For K-type thermocouple	Fluke 80CK-M Fluke Part Number 779942
Thermocouple Connector	For J-type thermocouple	80CJ-M Fluke Part Number 833046
Thermocouple Wire (K or J Type)	Standard	Omega
Dewar Flask/Cap	1-pint capacity	Thermos
Mercury Thermometer (either °C or °F)	0.02 °C resolution 0.05 °F resolution	Princo Model ASTM56C Princo Model ASTM56F

Performance Tests

Performance tests are recommended for incoming inspection, periodic maintenance, and for verifying the thermometer's specifications. If the thermometer fails any part of the performance tests, calibration and/or repair is indicated.

Use the following procedure to prepare the thermometer before beginning the performance tests or calibration procedures.

1. Allow the thermometer to stabilize to room temperature, $23\text{ °C} \pm 5\text{ °C}$ ($73\text{ °F} \pm 9\text{ °F}$).
2. Check the battery and replace it if necessary.

Display Test

Turn the thermometer on while pressing the HOLD button. All display segments are shown until the HOLD button is released. Check that all the display segments are showing as in Figure 3.

Note

Because pressing the HOLD button during power-up activates one of the thermometers other functions, take care to return the instrument to its normal function (if necessary).

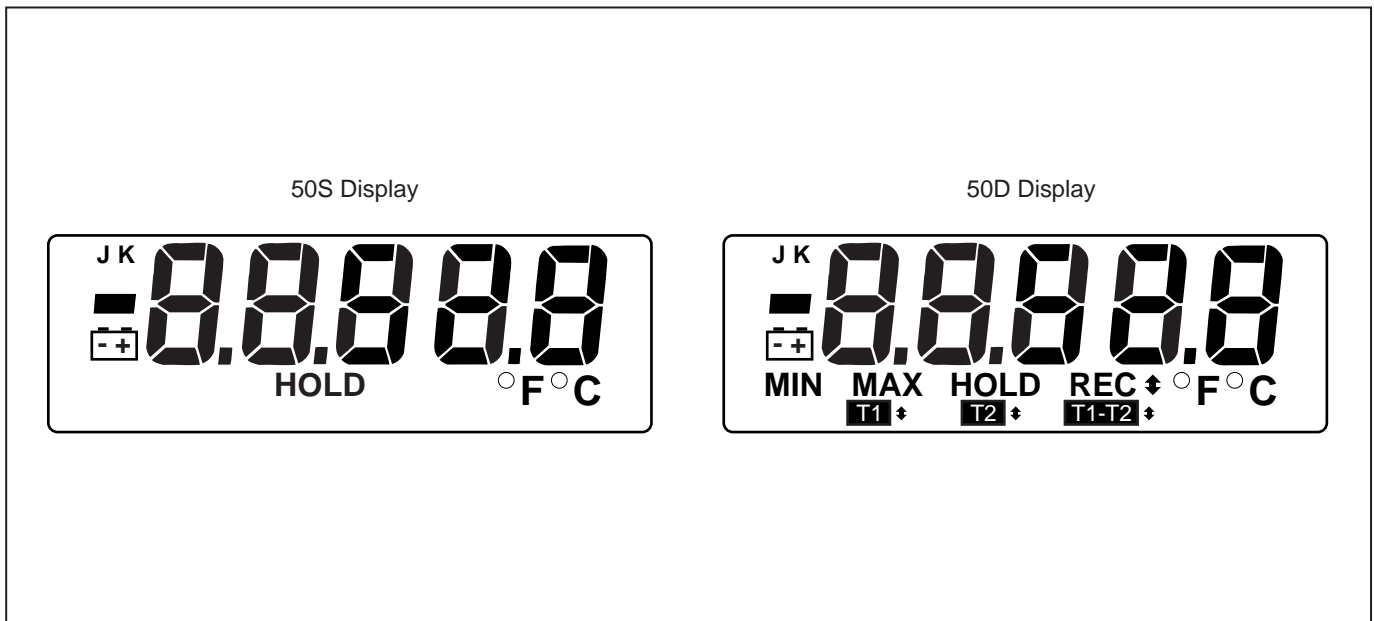

Figure 3. Display Segments

Wide Range Performance Test Procedure

This test verifies the instrument specifications. If the instrument fails this test, perform the calibration procedure. If the unit continues to fail, it should be taken to a Fluke service center.

Ice Bath Construction

To begin the wide range performance test procedure, first construct an ice bath using the following steps:

1. Prepare a Dewar Flask by drilling two holes in its cap to accept the thermometer and thermocouple wires, or use a standard laboratory cork.
2. Fill the Dewar Flask with shaved or crushed ice made from distilled water.
3. Fill the Dewar Flask with enough distilled water so that the ice turns to slush, but do not add enough water to float the ice.

Note

As the ice melts, siphon off the excess water and add more ice. Allow approximately 5 to 10 minutes for the water to drop back to the freezing point.

4. Replace the Dewar Flask cap or cork, and insert the thermocouple wires as shown in Figure 4.

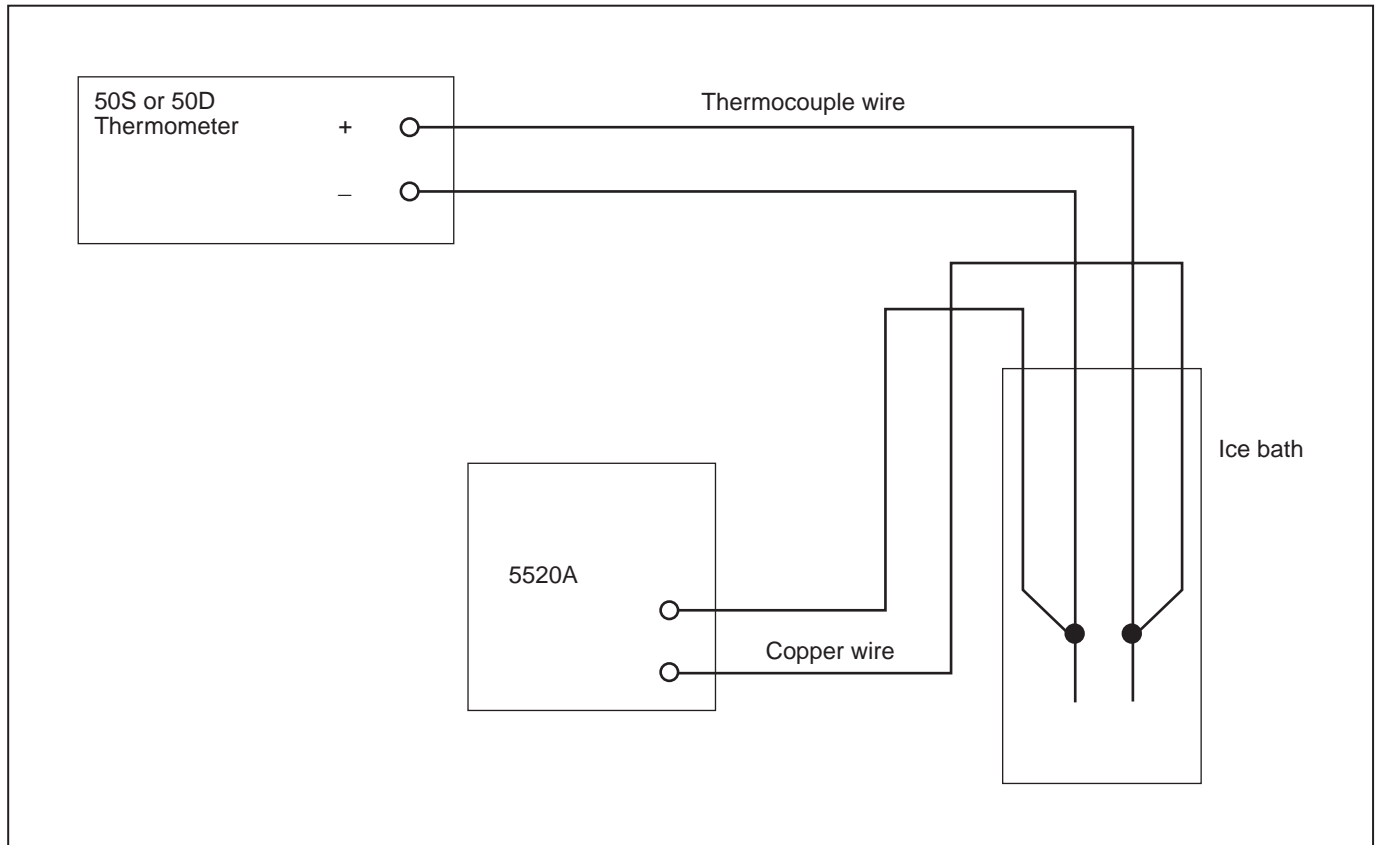
**Figure 4. Ice Bath Equipment Connections**

zf05f.eps

Ice Bath Test

Use the following procedure to test the thermometer. This test should be conducted on both thermocouple inputs of the 50D.

1. Connect the equipment as shown in Figure 4.
2. Insert the Mercury Thermometer to the same depth as the thermocouple wires and verify that the ice bath temperature is $0.0\text{ }^{\circ}\text{C} \pm 0.1\text{ }^{\circ}\text{C}$.
3. Short (or apply 0 mV) to the copper wires at the 5520A Calibrator.
4. Verify the thermometer reads $0.0\text{ }^{\circ}\text{C} \pm 0.4\text{ }^{\circ}\text{C}$.
5. If this test fails, reposition the thermocouple wires and Mercury Thermometer in the ice bath and repeat steps 2-4. If the test continues to fail, perform the calibration procedure, located later in this document.
6. Remove the short applied in step 3.
7. Using Table 3 (for the corresponding thermocouple type), obtain an output from the 5520A equal to the first value of the "Input Voltage (mV DC)" column, and verify that the thermometer reads within the limits specified.
8. Repeat these steps for the remaining voltages in the "Input Voltage (mV DC)" column.
9. Disconnect the thermocouple from the input terminals. This completes the ice bath test.

Table 3. Performance Test Values

Thermocouple Type	Input Voltage (mV DC)	Display Reading	
		°C	°F
K	-5.587	-182.0 ±(0.9)	-295.6 ±(1.6)
K	-3.211	-89.0 ±(0.8)	-128.2 ±(1.4)
K	21.919	530.0 ±(1.2)	986.0 ±(2.3)
K	54.297	1355.0 ±(2.1)	2471.0 ±(3.8)
J	-7.824	-197.0 ±(1.0)	-322.6 ±(1.7)
J	13.997	258.0 ±(1.1)	496.4 ±(1.9)
J	39.442	705.0 ±(1.5)	1301.0 ±(2.7)

Calibration

When calibrating the thermometer, refer to Figure 5 for the proper setup connections and Figure 6 for adjustment locations.

Caution

When directed to short a switch grid in the following procedures, use only the elastomeric switch pad that is supplied as pca damage may occur if a hard tool is used.

Thermometer Calibration

1. Turn the thermometer off and remove the top case leaving the Main PCA in the bottom case.
2. Simultaneously short the TP1 switch grid and turn on the thermometer by shorting the ON/OFF switch grid. Hold the elastomeric switch pad on TP1 for at least 3 seconds after the thermometer turns on. This puts the thermometer into the Thermocouple Calibration mode.
3. Allow the thermometer to stabilize at room temperature, $23\text{ }^{\circ}\text{C} \pm 5\text{ }^{\circ}\text{C}$ ($73\text{ }^{\circ}\text{F} \pm 9\text{ }^{\circ}\text{F}$).
4. Select °C mode. Select T1 if the thermometer is a Fluke 50D.
5. Adjust the 5520A for 0.00000V. Connect the 5520A output to the TP1 input.
6. Allow the thermometer reading to stabilize. Refer to Figure 6 and adjust the T1 offset adjustment (R7) for a display reading of $25.2\text{ }^{\circ}\text{C} \pm 0.1\text{ }^{\circ}\text{C}$.

If you are calibrating a Fluke 50S, skip the next two steps.

7. Leave the 5520A adjusted for 0.00000 V. Connect the 5520A output to the T2 input and select the T2 function.
8. Allow the reading to settle and adjust the T2 offset adjustment (R13) for a display reading of $25.2\text{ }^{\circ}\text{C} \pm 0.1\text{ }^{\circ}\text{C}$.
9. Adjust the 5520A for 53.807 mV output.
10. Allow the reading to stabilize and adjust (R21) for a display reading of $+1370.0\text{ }^{\circ}\text{C} \pm 0.4\text{ }^{\circ}\text{C}$.
11. Disconnect the thermometer from the 5520A. Turn the thermometer off by shorting the ON/OFF switch grid.
12. With an elastomeric switch pad in both hands, use the left pad to short out the TP2 grid, and use the right pad to first turn on the instrument and then quickly short out the VIEW switch grid. Hold this

50S & 50D Thermometer

Calibration Information

position until the display is locked in self-test (all LCD segments on). This thermometer is now in the Reference Junction Sensor calibration mode. Shorting out the VIEW switch grid turns off a filter so that the reading stabilizes immediately.

- Using the 80T-150U and the Fluke 87 Series IV Digital Multimeter (DMM), measure the reference junction transistor temperature by placing the 80T-150U probe tip against Q1, located in the middle hole of the isothermal block. Wait for the temperature reading to stabilize.
- Adjust R16 for a temperature reading that is the same as displayed on the DMM.
- Turn the thermometer OFF by shorting the ON/OFF switch grid, and reattach the top-case.

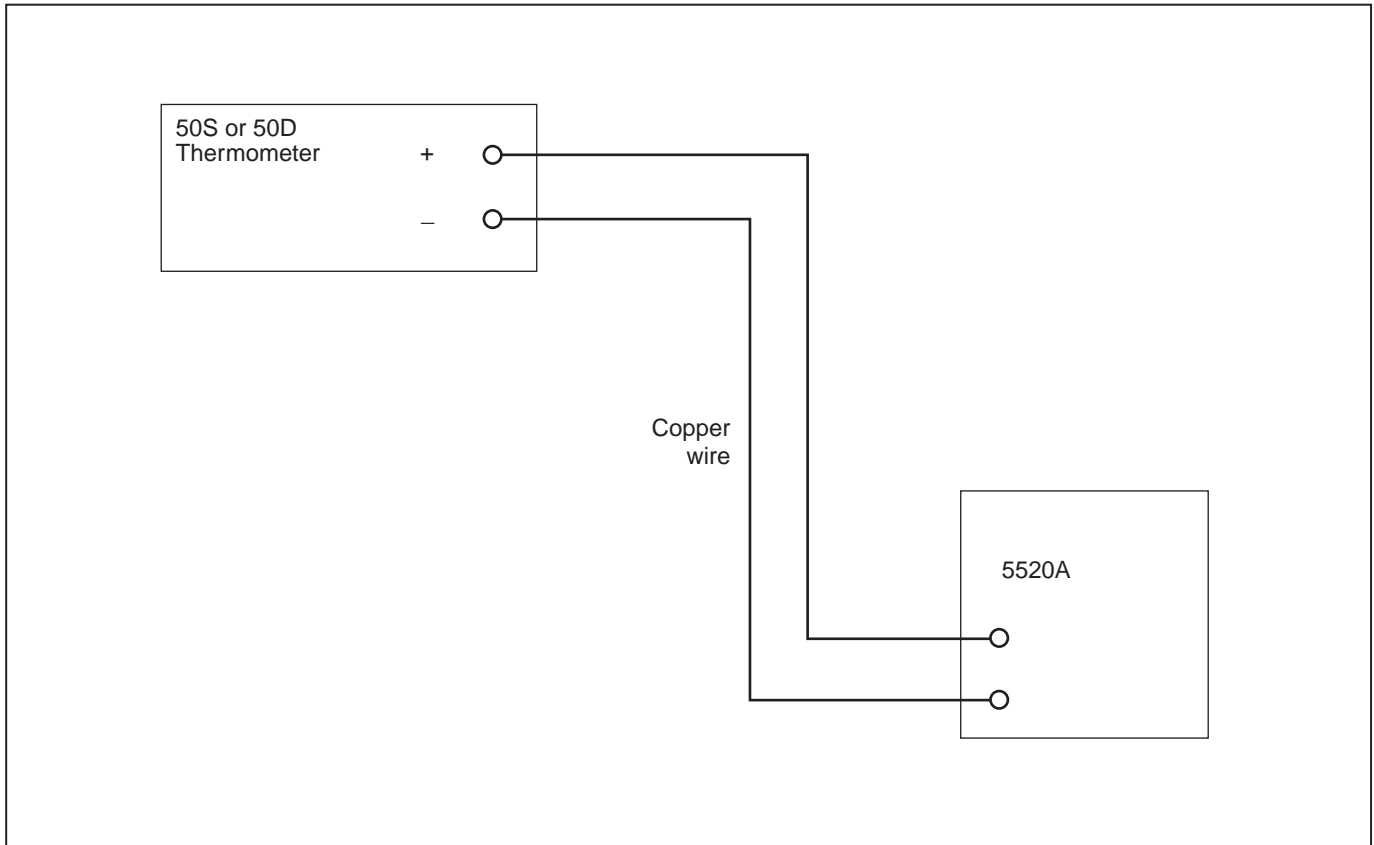

Figure 5. Calibration Connections

z107f.eps

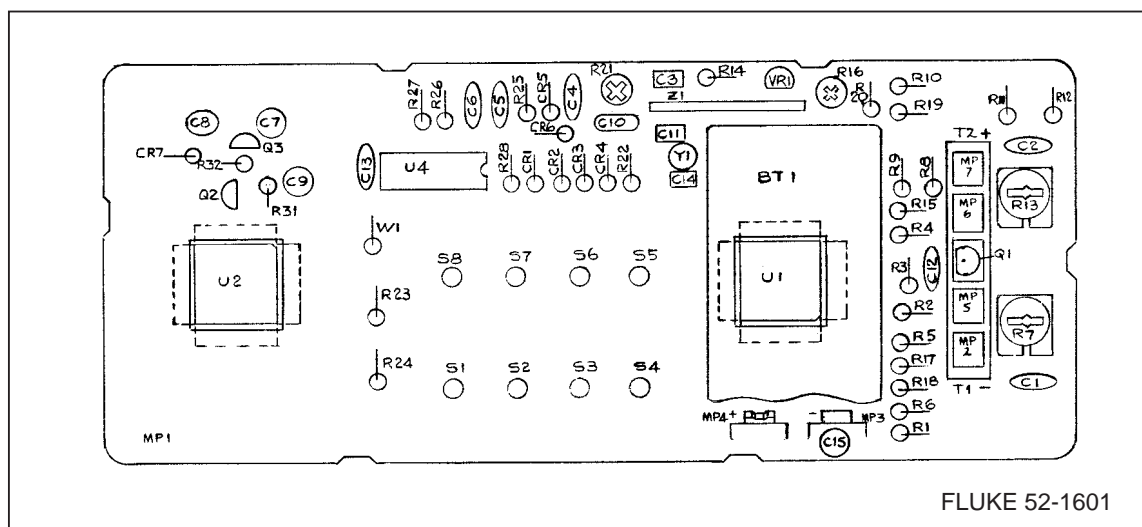

Figure 6. A1 Main PCA Adjustments

z109f.eps

Optimizing Thermometer Performance in the Negative Temperature Range

Perform the following steps to optimize the thermometer performance in the negative temperature range:

1. Put the thermometer in normal operating mode. Normal operation can be achieved by turning the thermometer OFF and then ON. No other thermometer buttons should be pressed during the power cycle operation.
2. Insert a known good thermocouple in an ice bath (see “Ice Bath Construction” earlier in this document).
3. Insert the Mercury Thermometer to the same depth as the thermocouple wires verifying the ice bath temperature is $0.0\text{ }^{\circ}\text{C} \pm 0.1\text{ }^{\circ}\text{C}$.
4. Connect the other end of the thermocouple wire to the T1 input of the thermometer and allow the instrument reading to stabilize.
5. Slowly, and in small increments, adjust R7 (T1 offset) until the thermometer reading matches the Mercury Thermometer reading. Allow the thermometer reading to stabilize and repeat the adjustment as necessary until a stable and correct reading can be attained.
6. Repeat steps 4 and 5 for R13 (T2 offset, Fluke 50D only).

Thermocouple Input Calibration (Optional)

Note

This adjustment procedure counteracts the adjustments made in the “Optimizing Performance in the Negative Temperature Range” section of this document.

This procedure optimizes the 50S or 50D for measurement with a specific thermocouple.

Perform the thermocouple input calibration using the following procedure:

1. Construct an ambient temperature lag bath as shown in Figure 7.
2. Connect the thermocouple to the thermometer input terminals.
3. Select the applicable switch position (T1 or T2) and temperature scale ($^{\circ}\text{C}$ or $^{\circ}\text{F}$).
4. Insert the probe into a room temperature lag bath.

50S & 50D Thermometer

Calibration Information

5. Allow the system to stabilize, then adjust T1 or T2 offset adjustments for a temperature display equal to the reading of the lag bath reference thermometer.
6. Calibration of the thermometers is complete. Disconnect all test equipment from the instrument.

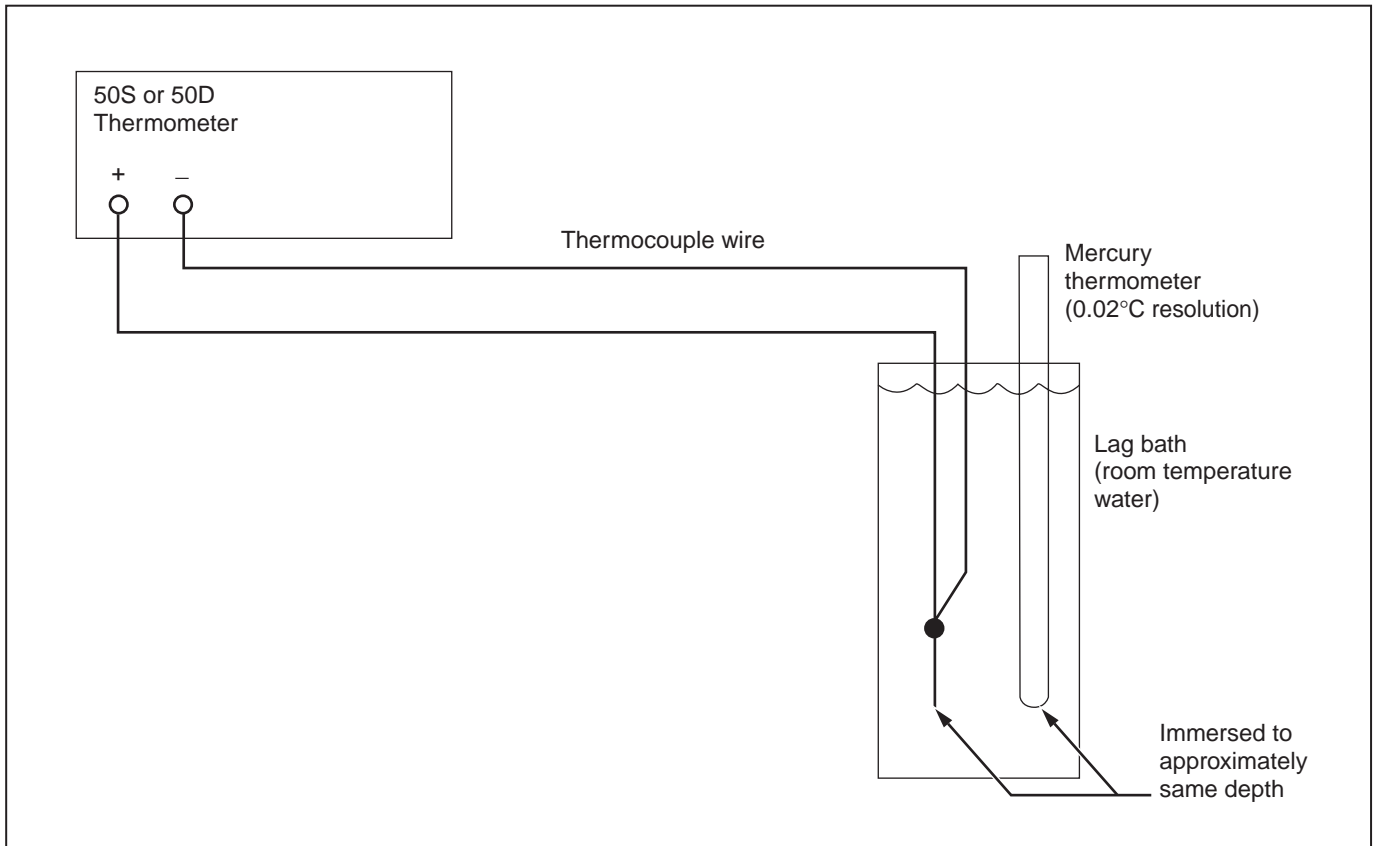

zf06f.eps

Figure 7. Room Temperature Lag Bath

Replaceable Parts

Refer to Table 4 for all replacement part numbers and Figure 8 for part locations. Unless specified in the “Model Number” column, all parts are for all units. To order replaceable parts, see the “Service Centers” section of this manual.

Table 4. 50S and 50D Replaceable Parts

Item Number	Qty.	Fluke Part Number	Description	Model Number
1	1	778191	MAIN PCA	50S
	1	778209	MAIN PCA	50D
2	1	696534	BATTERY, PRIMARY, 9V, 0-15MA	All
3	4	832246	SCREW, PH, P, AM THD FORM, STL, 5-14, .750	All
4	1	519116	SCREW, PH, P, THD FORM, STL, 4-24, .250	All
5	4	448456	SCREW, PH, P, AM THD FORM, STL, 4-14, .375	All
6	1	1280490	CASE, TOP	50S
		1280483	CASE, TOP	50D
7	1	1280766	CASE, BOTTOM	50S
		1280753	CASE, BOTTOM	50D
8	1	646653	BRACKET, LCD	All
9	1	1280151	MASK, BRACKET, FLUKE 50S	50S
		1280160	MASK, BRACKET, FLUKE 50D	50D
10	1	745794	ISOTHERMAL BLOCK	All
11	2	649632	CONNECTOR , ELASTOMERIC, LCD TO PWB, 1.900 L	All
12	1	761924	BOTTOM SHIELD, MYLAR	All
13	4	640565	FOOT, NON-SKID	All
14	1	844340	LABEL, WINDOW	All
15	1	791343	WINDOW, LCD (BLANK)	All
16	1	742205	LCD FLUKE-51, LCD, 5 DIGIT, TEMPERATURE, MULTIPLEXED	50S
		741314	LCD FLUKE-52, LCD, 5 DIGIT, TEMPERATURE, MULTIPLEXED	50D
Not shown	1	773135	THERMO COUPLE ASSY, T/C ASSY, K-TYPE, BEADED, MOLDED-PLUG	50S
	2			50D
Not shown	1	1278540	MULTI-LANGUAGE, FLUKE 50S & 50D USERS MANUAL	All
Not shown	1	890298	HOLSTER & FLEXSTAND ASSY, YELLOW	All

Free Manuals Download Website

<http://myh66.com>

<http://usermanuals.us>

<http://www.somanuals.com>

<http://www.4manuals.cc>

<http://www.manual-lib.com>

<http://www.404manual.com>

<http://www.luxmanual.com>

<http://aubethermostatmanual.com>

Golf course search by state

<http://golfingnear.com>

Email search by domain

<http://emailbydomain.com>

Auto manuals search

<http://auto.somanuals.com>

TV manuals search

<http://tv.somanuals.com>