



**IEEE 1394 Camera Series (IM-30/IM-100)**  
**User's Manual**



**Manual Version: 2.1**  
**Revision Date: April 30, 2008**

# Table of Contents

<b>1</b>	<b>Introduction.....</b>	<b>4</b>
1.1	Features.....	4
1.2	Applications.....	4
1.3	System Requirement.....	4
1.4	Function Descriptions.....	5
1.4.1	AOI (Area of Interest).....	5
1.4.2	Test Pattern.....	6
1.4.3	Mirror Image.....	7
1.4.4	Gain and Brightness.....	8
1.4.5	Lookup Table.....	10
1.4.6	Shutter (Exposure).....	12
1.4.7	Input/Output.....	13
1.4.8	External Trigger.....	15
1.4.9	Strobe Control.....	17
1.5	Spectral Response.....	18
1.6	Integrate Enabled Signal Timing.....	19
1.7	Benchmarks.....	20
<b>2</b>	<b>Hardware Reference.....</b>	<b>21</b>
2.1	MAVIS IM-30/IM-100.....	21
2.1.1	Camera Specification.....	21
2.1.2	Camera Interface.....	22
2.1.3	Standard Package Contents.....	22
2.2	Optional Accessory.....	23
2.2.1	1394 Dual-port Card: IOI-4601-21.....	23
2.2.2	1394 Latch Cable: CA-1394-45.....	23
2.2.3	1394 Repeater: 1394R3B.....	24
<b>3</b>	<b>Installation Guide.....</b>	<b>25</b>
3.1	Hardware Installation.....	25
3.1.1	IPC/PC Platform.....	25
3.1.2	Notebook PC / PCMCIA Socket.....	27
3.2	Driver Installation.....	29
3.2.1	For Visual Studio (VC/VB/BCB/VC#.NET) Users.....	29
3.2.2	For LabVIEW Users.....	33
<b>4</b>	<b>EZView Utility.....</b>	<b>34</b>
4.1	Overview.....	34

4.2	Component Description.....	35
<b>5</b>	<b>EzVIEW_Fly Utility .....</b>	<b>42</b>
5.1	Overview .....	42
5.2	Configuration.....	43
5.3	Help – About EzVIEW_Fly.....	47
5.4	Tool Icons .....	47
<b>6</b>	<b>Function Library .....</b>	<b>50</b>
6.1	List of Functions .....	51
6.2	Programming Flowchart .....	52
6.3	Camera Management.....	56
6.4	Camera Acquisition .....	59
6.5	Camera Configuration .....	67
6.6	Digital Input/Output.....	75
6.7	External Trigger .....	82
6.8	Strobe Control .....	87
6.9	Lookup Table.....	93
6.10	AOI (Area of Interest) .....	97
6.11	Advanced Features .....	99
6.12	Sample Programs .....	101
	6.12.1 Sample program for VC++/BCB/C#.NET .....	101
	6.12.2 Sample program for VB.....	102
<b>7</b>	<b>Mechanical .....</b>	<b>103</b>
<b>8</b>	<b>Appendix .....</b>	<b>104</b>
8.1	Standards Compliance .....	104
8.2	Glossary .....	105
8.3	Revision History .....	107
	<b>Warranty Policy.....</b>	<b>108</b>
	<b>ICP DAS Worldwide .....</b>	<b>109</b>

# 1 Introduction

MAVIS is a new and exciting vision product line from ICP DAS, designed specifically for industry machine vision applications. The MAVIS IM series is designed to meet or exceed IEEE 1394 standards, while offering industry leading VGA resolution, high-performance frame rates, and a competitive price point! The Mavis IM30 offers 30fps for low-cost progressive-scan inspection applications, while the Mavis IM100 can offer up to 100fps, in full resolution for advanced high-speed inspection applications.

## 1.1 Features

- Digital IEEE1394 video output
- Progressive-scan for on-the-fly applications
- Acquisition speed up to 100fps in full resolution
- Build-in 8MB memory buffer
- Flexible electric exposure control
- Robust external trigger I/O interface supported
- Free SDK API for VC, VB, BCB and C#.NET
- Compatible with NI-IMAQ-1394
- Driver supports Windows2000/XP

## 1.2 Applications

- Semiconductor
- Component inspection
- Manufacturing quality control
- Food and beverage inspection
- Microscopy and medical imaging

## 1.3 System Requirement

To ensure seamless operation, ICP DAS recommends that your system meets the minimum requirements below:

- Platform: Pentium III 800MHz CPU, 256MB DDRAM or above.
- VGA display: AGP 4X or above.
- Display setting: 800 x 600 resolution or above.
- 32-bit OS only:
  - if using Windows 2000, please upgrade to Service Pack 4 or above.
  - If using Windows XP, please upgrade to Service Pack 2 or above.

\*\*Please refer 1.7 Benchmark for system limitation information.\*\*

## 1.4 Function Descriptions

In this section, we will outline the MAVIS IM-30/IM-100 camera control functions. To ensure proper implementation, please carefully review the, limitation parameters and formula calculations, listed below.

### 1.4.1 AOI (Area of Interest)

The AOI (Area of Interest) function allows users to select an area of interest, for the camera's CMOS array to specifically read, display, and transmit.

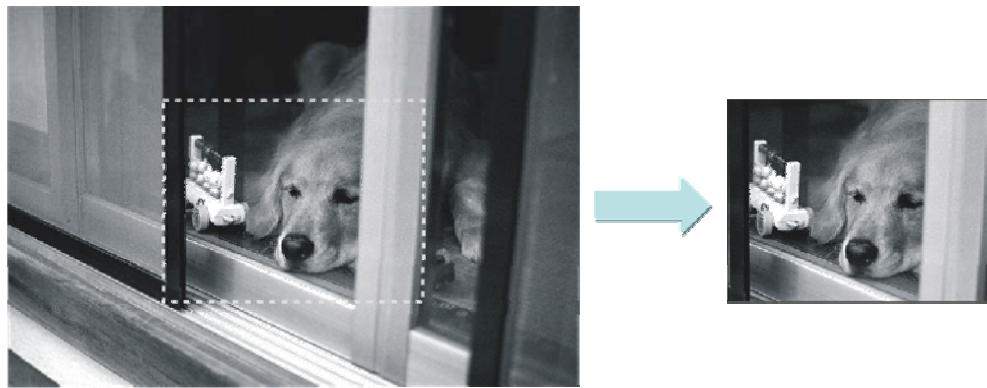

Figure 1-1: AOI (Area of Interest)

The AOI function will also enhance camera acquisition speed, however users must still consider the following factors:

- (1) The amount of time it takes to transfer a captured image from the CMOS sensor to the frame buffer.
- (2) The amount of time it takes to transfer an image from the frame buffer to the PC via 1394 bus.
- (3) The camera exposure time setting.

Below, are three formulas that can help you to calculate the maximum frame rate, while using the AOI function. Please note that the lowest value will determine the maximum frame rate for the given AOI.

Formula 1: ***Max. Frames/s = 1 / (((AOI High + 2) x 15.28us) + 15.28us)***

Formula 2: ***Max. Frames/s = 1 / (Packet per frame x 125us)***

Formula 3: ***Max. Frames/s = 1 / (exposure time in us + 28us)***

For example, if your AOI is set for 200 columns wide and 240 rows high, and exposure time is set for 1000us. Also the packet per frame with the

current settings is 5.

Formula 1:

$$\text{Max. Frames/s} = 1 / (((240 + 2) \times 15.28\text{us}) + 15.28\text{us})$$

$$\text{Max. Frames/s} = 269.2$$

Formula 2:

$$\text{Max. Frames/s} = 1 / (5 \times 125\text{us})$$

$$\text{Max. Frames/s} = 1600$$

Formula 3:

$$\text{Max. Frames/s} = 1 / (1000 \text{ us} + 28\text{us})$$

$$\text{Max. Frames/s} = 972.76$$

By using the calculations above, the AOI for this particular scenario can be calculated at 269 frames per second.

### 1.4.2 Test Pattern

The MAVIS IM-30/IM-100 series cameras offer an internal generated test pattern for testing camera transmission. The test pattern will show a gray bar running diagonally, moving upwards at 1pixel/frame.

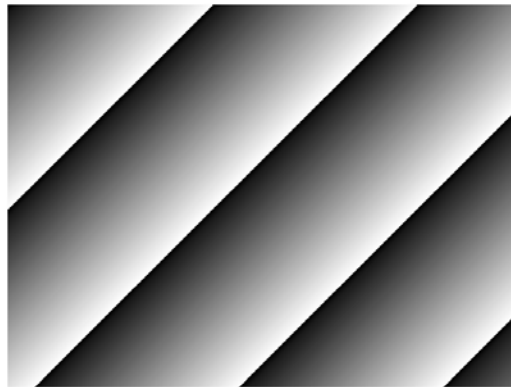

Figure 1-2: MAVIS IM-30/IM-100 gray bar test pattern



**When setting camera to test pattern mode, then camera will keep this configuration even after rebooting the camera. Please be sure to disable test pattern mode after your test completed testing.**

### 1.4.3 Mirror Image

The mirror image feature is only available in the MAVIS IM-100 camera. When you enable mirror image mode, the camera will reflect the image's vertical axis, before data is transmitted out of the camera.

In factory mode, the mirror image is disabled and the order of transmission for the pixels in each line is pixel 1, pixel 2, pixel 3, to 640. When mirror image mode is enabled, the order of transmission for each line is pixel 640, pixel 639, pixel 638, to pixel 1.

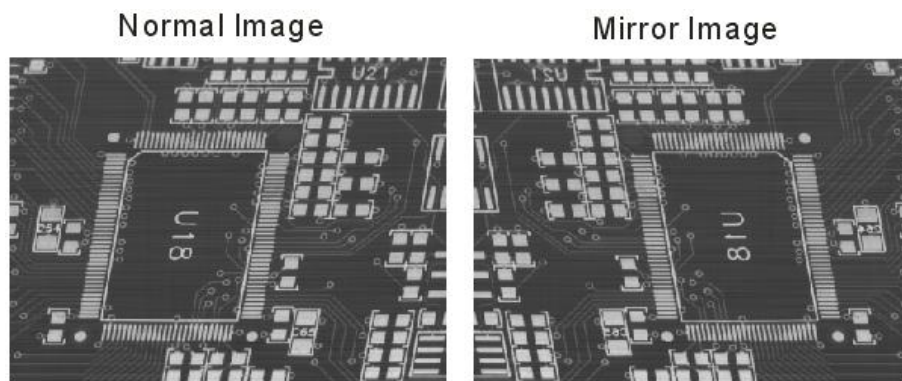

Figure 1-3: Mirror Imaging



If you are using the AOI mode (area of interest) in conjunction with mirror image mode, the apparent location of your AOI may change. You may need to adjust the location and size of the AOI.

### 1.4.4 Gain and Brightness

The Gain and Brightness adjustment functions are accomplished by manipulation of the sensor's digital output signal.

Please refer in Figure 1-4; when the gain is set to 0, the full 10bit output range of the camera's CMOS sensor will mapped directly to the 8bit output range of the camera. In this situation, a gray value of 0 is output from the camera when the pixels in the sensor are exposed to no light and a gray value of 255 is output when the pixels are exposed to very bright light. This condition is defined as 0dB of system gain for the camera.

As shown in the three graphs below, increasing the gain setting to a value greater than 0, maps a smaller portion of the sensor's 10bit range to the camera 8bit output. When a smaller portion of the sensor range is mapped to the camera output, the camera's sensitivity to a change in light level is increased.

This feature can be useful when at your brightest exposure, a gray value of less than 255 is achieved. For example, if a maximum gray value of 127 is achieved with bright light, you could increase the gain setting so that the camera is operating at 6dB; thus seeing an increase in gray values to 254.

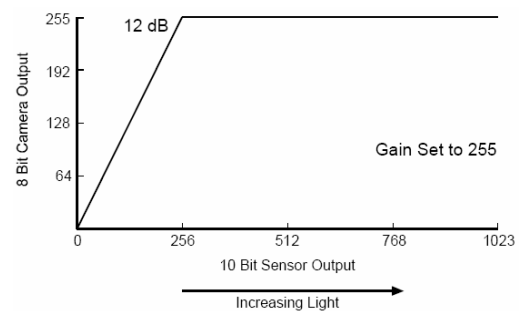
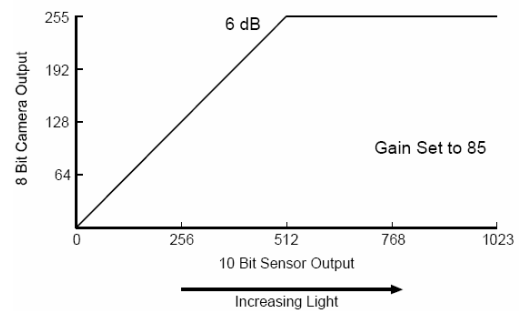
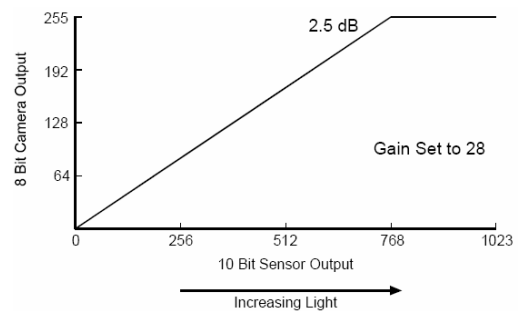
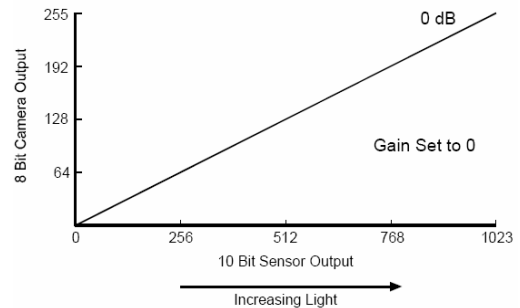

Figure 1-4: Gain Settings Mapping



Value	0	28	43	85	128	170	213	255
dB	0dB	2.5dB	3.5dB	6dB	8dB	9.5dB	10.9dB	12dB

**Table 1-1 Gain value settings**

Please refer to “Figure 1-5”; Which illustrates the effect of setting the brightness higher than the default value of 725. It should be noted that this setting moves the response curve to the left; therefore increasing the 8bit value output from the camera for any given 10bit value from the sensor, and also increasing the apparent brightness of the image.

The bottom graph illustrates the effects of setting the brightness lower than the default value of 725. It should be noted that this setting moves the response curve to the right; therefore decreasing the 8bit value output from the camera for any given 10bit value from the sensor and also decreasing the apparent brightness of the image.

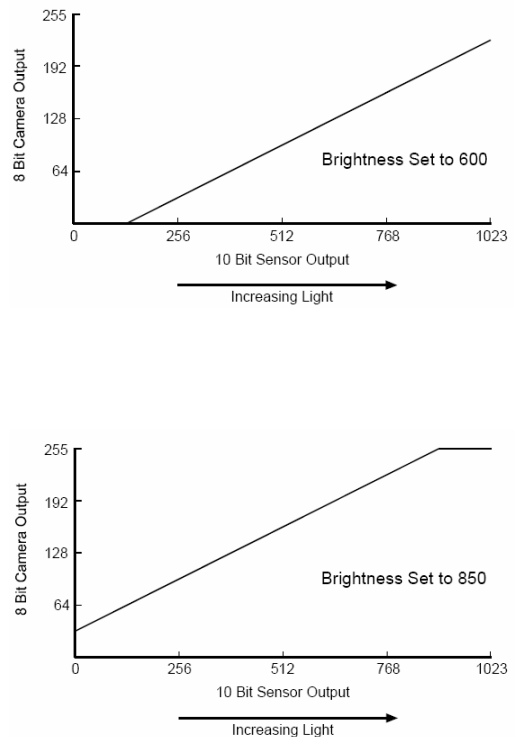

**Figure 1-5: Brightness Settings Mapping**

### 1.4.5 Lookup Table

MAVIS IM-30/IM-100 cameras have a sensor that reads pixel value at a 10bit depth; however, the camera outputs pixel values at an 8bit depth. When set for 8bit output, the camera normally uses an internal process to convert the 10bit pixel values from the sensor to the 8bit values transmitted out of the camera. When making the 10 to 8bit conversion, the internal process takes the camera current gain and brightness settings into account.

The MAVIS IM-30/IM-100 camera allows users to use a custom lookup table to map the 10bit sensor output to 8bit camera output rather than using the internal process. When the custom lookup table is enabled, the gain and brightness settings have no effect. The 10 to 8bit conversion is based solely on the lookup table.

The lookup table is essentially just a list of 1024 values. Each value in the table represents the 8bit value that will be transmitted out of the camera when the sensor reports a particular 10bit value for a pixel. The first number in the table represents the 8bit value that will be transmitted out of the camera when the sensor reports that a pixel has a value of 0. The second number in the table represents the 8bit value that will be transmitted out of the camera when the sensor reports that a pixel has a value of 1. The third number in the table represents the 8bit value that will be transmitted out of the camera when the sensor reports that a pixel has a value of 2. And so on.

The advantage of the lookup table feature is that it allows the user to customize the response curve of the camera.

The graphs below represent the contents of two typical lookup tables.

Figure 1-6 is for a lookup table where the values are arranged so that the output of the camera increases linearly as the sensor output increases.

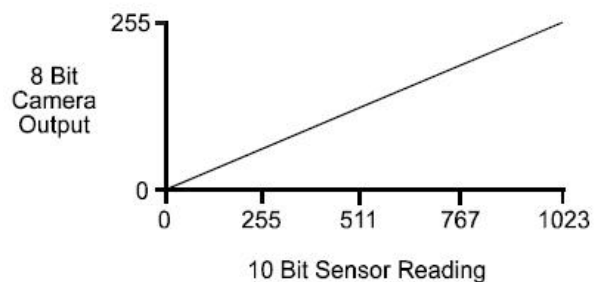

Figure 1-6: LUT with Values Mapped in a Linear Fashion

Figure 1-7 is for a lookup table where the values are arranged so that the camera output increases quickly as the sensor output moves from 0 through 511 and increases gradually as the sensor output moves from 512 through 1023.

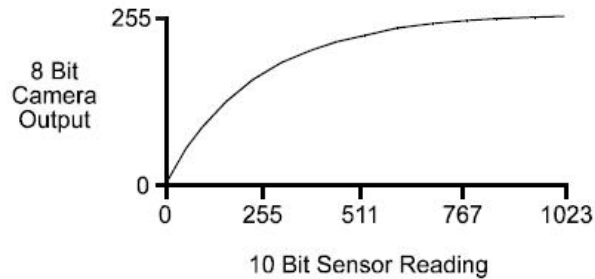

Figure 1-7: LUT with Values Mapped for Higher Camera Output at Low Sensor Readings

- **Upload a Lookup Table**

The EZView utility offers an LUT enable and upload button that can be used to easily load a file containing a customized lookup table into the camera. The file must be plain text and must be formatted correctly.

The file must have 1024 lines with each line containing two comma-separated values. The first value on each line represents a 10 bit pixel reading from the sensor and the second value represents the corresponding 8bit output that will be transmitted from the camera.

The sample below shows part of a typical text file for a lookup table. Assuming that you have enabled the lookup table feature on your camera and used the upload button to load a file similar to the sample into the camera:

The sensor reports that a pixel has a value of 1, the camera will output a value of 0.

The sensor report that a pixel has a value of 6, the camera will output a value of 1.

The sensor report that a pixel has a value of 1019, the camera will output a value of 254.

```

0,0
1,0
2,0
3,0
4,1
5,1
6,1
7,1
8,2
9,2
10,2
11,2
12,3
13,3
14,3
15,3
16,4
17,4
18,4
19,4
20,5
21,5
1010,252
1011,252
1012,253
1013,253
1014,253
1015,253
1016,254
1017,254
1018,254
1019,254
1020,255
1021,255
1022,255
1023,255

```

Figure 1-8 Sample text file for use LUT upload

#### 1.4.6 Shutter (Exposure)

The camera exposure time is related with shutter speed or camera frame rate. MAVIS IM-30/IM-100 allowed to set shutter speed range from 20us to 81900us.

While user set the exposure time (shutter speed) longer than frame acquisition speed then camera frame rate will be reduced.

For example: if user set the frame rate in 30fps but set the shutter speed in 36000us.

***Maximum exposure time (Shutter speed) = 1s / frame rate***

***36000us = 1s / frame rate***

***Camera real frame rate = 27 frames per second***

## 1.4.7 Input/Output

- **Input Ports**

The MAVIS IM-30/IM-100 offers 2 input ports; designated as Input Port 0 and Input Port 1. Both ports are TTL level. The input ports are accessed via the 10-pin circular connectors on the back of the camera. Please refer Table 2-1 for input port pin assignments.

For each port, an input voltage between 0.0 and 1.5VDC indicates a logical 0. An input voltage between 3.5 and 5.0 VDC indicates a logical 1. Typical current draw for the input port is 1mA.

Figure 1-6 is an example of a typical circuit that you can use to input a signal into the MAVIS IM-30/IM-100 cameras.

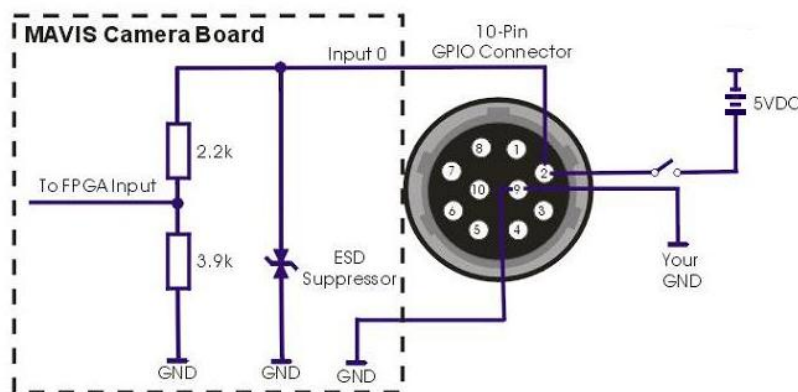

**Figure 1-9: Typical Input Circuit**

By default, Input Port 0 is assigned to receive an external trigger (Ex-Trig) signal that can be used to control the start of exposure. Also you can change the Ex-Trig signal to Input Port 1 and please refer “5.6 External Trigger” for detail information.

- **Output Ports**

The MAVIS IM-30/IM-100 offers 4 output ports; designated as Output Port 0, Output Port 1, Output Port 2 and Output Port 3, all are TTL level. The output ports are accessed via the 10-pin circular connectors on the back of the camera. Please refer Table 2-1 for input port pin assignments.

For each port, an output voltage between 0.0 and 0.44VDC indicates a logical 0. The maximum low level output voltage (i.e., 0.44VDC) will be present when the driver is sinking the maximum allowed input current of

24mA. An output voltage between 4.2 and 5.0VDC indicates a logical 1. The minimum high level output voltage (i.e., 4.2VDC) will be present when the driver is sourcing the maximum allowed output current of 24mA.

Figure 1-7 is an example of a typical circuit that you can use to monitor an output port with a LED or an Opto-coupler. Note that current in the circuit is limited by an external resistor.

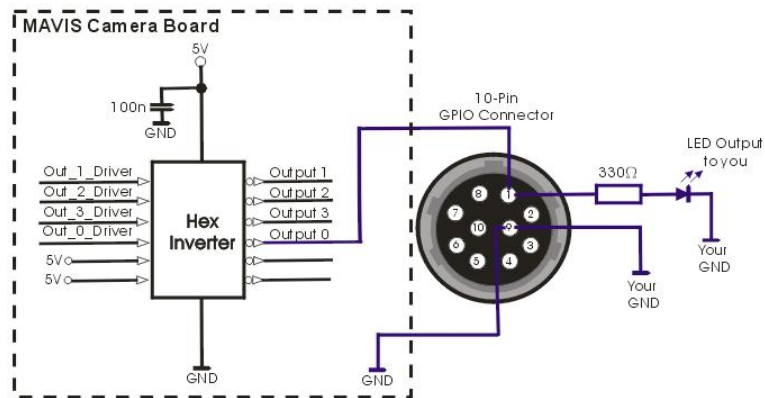

**Figure 1-10: Typical Output Signal**

By default, Output Port 0 is assigned to transmit an integration enabled (Int-En) signal that indicates when exposure is taking place. By default, Output Port 1 is assigned to transmit a trigger ready (Trig-Rdy) signal that goes high to indicate the earliest point at which exposure start for the next frame can be triggered. Please refer “1.6 Integrate Enabled Signal Timing” for a detailed camera signal integrate timing chart. The pin assignment of the camera output signals to physical output ports can be changed. Please refer “5.7 External Trigger” for detailed information.

### 1.4.8 External Trigger

The external trigger (Ex-Trig) input signal can be used to control the start of exposure. A rising edge or a falling edge can also be used to trigger exposure start. The External Trigger Mode is also used to enable the Ex-Trig exposure start control; enabling users to select rising or falling edge triggering and to assign a physical input port to receive the Ex-Trig signal.

The Ex-Trig signal can be periodic or non-periodic. When the camera is operating under control of an Ex-Trig signal, the period of the Ex-Trig signal determines the camera's frame rate:

$$1 / \text{Ex-Trig period per second} = \text{frame rate}$$

For example, if you are operating a camera with an Ex-Trig signal period of 20ms (0.02s):

$$1/0.02 = 50 \text{ fps}$$

So in this case, the frame rate is 50fps

The minimum high time for a rising edge trigger (or low time for a falling edge trigger) is 1us.

#### **Exposure Modes**

If you are triggering the camera with an Ex-Trig signal, two exposure modes are available, programmable mode and level controlled mode.

#### **Programmable Exposure Mode**

When programmable mode is selected, the length of the exposure is determined by the shutter setting described in "1.4.6 Shutter (Exposure)". If the camera is set for rising edge triggering, exposure starts when the Ex-Trig signal rises. If the camera is set for falling edge triggering, exposure starts when the Ex-Trig signal falls.

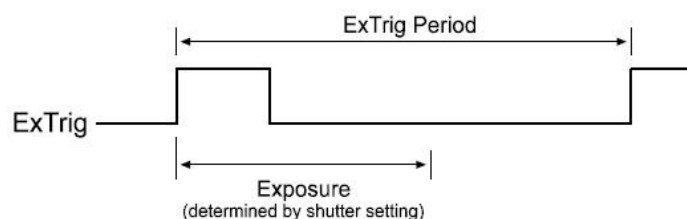
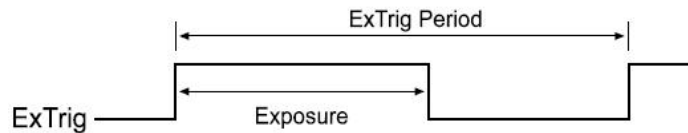

Figure 1-11: Programmable Exposure with rising edge triggering

### ***Level Controlled Exposure Mode***

When level controlled mode is selected, the length of the exposure is determined by Ex-Trig signal alone. If the camera is set for rising edge triggering, exposure begins when the Ex-Trig signal rises and continues until Ex-Trig signal falls. If the camera is set for falling edge triggering, exposure begins when Ex-Trig signal falls and continues until Ex-Trig signal rises.



**Figure 1-12: Level Controlled Exposure with rising edge triggering**



### 1.4.9 Strobe Control

This feature allows a user to enable and parameterize up to four strobe light control output signals. The signals are designated as Strobe 0, Strobe 1, Strobe 2, and Strobe3. Each strobe signal can be set to on or off and active high or low by logical value, please refer to section 5, "Function Library", for command definitions.

The strobe delay is determined by a combination of two values. The first is the setting in the Delay Value and the range from 0 to 4095. The second is the Strobe Delay Time Base which has a default value of 1/1024 ms.

$$\text{Strobe Delay} = (\text{Strobe Delay Value Setting}) \times (\text{Strobe Delay Time Base})$$

For example: If Delay Value of Strobe 0 is set to 120, then Strobe 0 delay will be 120/1024ms (or approximately 117us).

The Strobe delay will determine the time between the start of image exposure and when the strobe signal changes state as show in Figure 1-13.

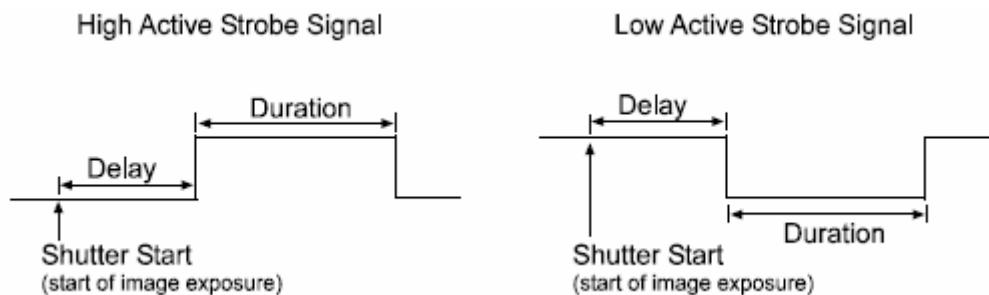

Figure 1-13: Strobe Signal

As mentioned above, the strobe delay time base is normally fixed at 1/1024ms and the strobe delay is normally adjusted by changing the delay value setting only. However, if you require a delay that is longer then what you can achieve by changing the strobe delay value alone, the strobe delay time base can also be changed. The strobe time base range has a multiplier of 1 to 85.

For example: with Delay Value of Strobe 1 set to 200 and a Delay Time Base of 20:

$$\text{Strobe1 Delay} = (\text{Strobe1 Delay Value Setting}) \times (\text{Strobe Delay Time Base})$$

$$\text{Strobe1 Delay} = (200) \times (20/1024\text{ms})$$

$$\text{Strobe1 Delay} = 3.9\text{ms}$$

## 1.5 Spectral Response

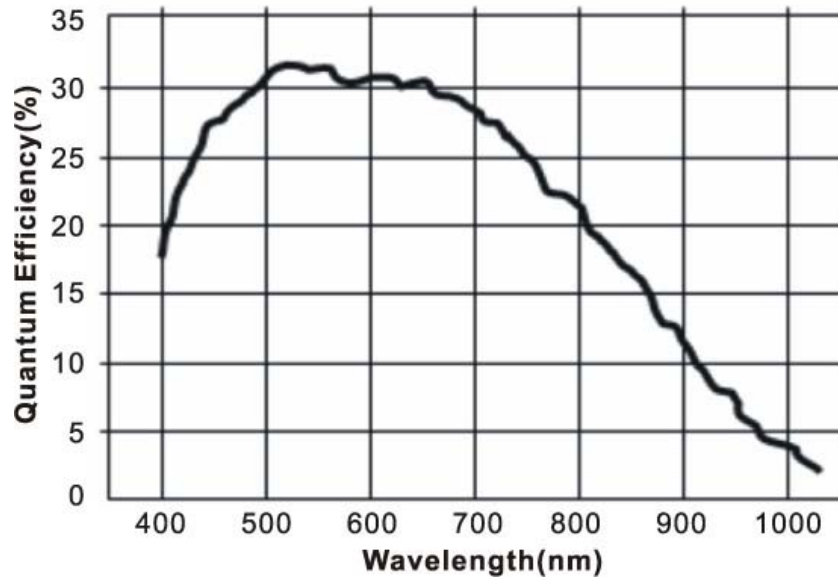

Figure 1-11: MAVIS IM30/IM100 Camera Spectral Response



The camera spectral response curve excludes Lens and lighting source characteristics.

## 1.6 Integrate Enabled Signal Timing

The time between the start of exposure and the rise of the Integrate Enabled (Int-En) signal will be less than 10 nanoseconds. The time between the end of exposure and the fall of Int-En signal will also be less than 10 nanoseconds. This is very good performance, and is due to the design of the camera output port circuitry.

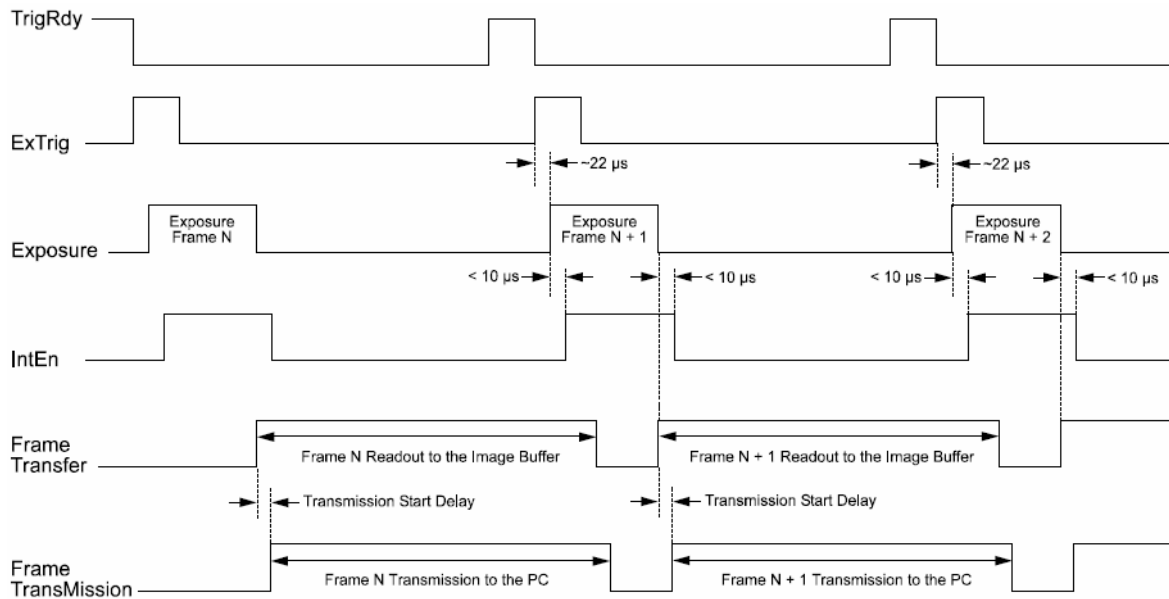

Figure 1-12: MAVIS IM-30/IM-100 Camera Timing Chart

## 1.7 Benchmarks

Due the platform and 1394 Host controller bandwidth performance, we have listed some benchmark information for your reference.

### **Benchmark test results**

Platform Type	Industrial PC Platform	Consumer PC	VISION BOX
Platform Spec.	ROBO-8712E SBC Intel Pentium4 2.4GHz 512MB DDRAM 32-bit, 33MHz PCI Chipset: Intel 845GV 32-bit OS: Windows XP Service Pack 2	ASUS P4S800-MXSE Celeron 2.66GHz 256MB DDR RAM 32-bit, 33MHz PCI Chipset: SiS661FX 32-bit OS: Windows XP Service Pack 2	VB-216C Intel Core Duo 1.66GHz 2GB DDR2 533 32-bit, 33MHz PCI Chipset: Intel 945GME 32-bit OS: Windows XP Embedded Service Pack2
Max. input guaranteed:	MAVIS IM-100* x 3pcs or MAVIS IM-30** x 10pcs	MAVIS IM-100* x 2pcs or MAVIS IM-30** x 6pcs	MAVIS IM-100* x 3pcs or MAVIS IM-30** x 8pcs (by hub function of 1394R3B)

MAVIS acquisition speed data rates:

\* When the IM-100 is at full speed image acquisition (100 frames per second) the data rate will be up to 29.3MB per second.

\*\*When the IM-30 is at full speed image acquisition (30 frames per second) the data rate will be up to 8.79MB per second.

Some IEEE 1394 interface cards offer three IEEE 1394 connectors but one IEEE 1394 Host controller only. Therefore when you plug more than one IEEE 1394 cameras, the bandwidth will be considered shared usage. Please see below for an explanation of a “bandwidth sharing” situation, when the number of host controllers is different.

Number of Host Controllers	IM-100 x 1pcs	IM-100 x 2pcs	IM-100 x 3pcs
IEEE 1394 host controller x 1	100fps/CH	60fps/CH	30fps/CH
IEEE 1394 host controller x 2	100fps/CH	100fps/CH	One CH 100fps, Two CH 60fps/CH

Number of Host Controllers	IM-30 x 1pcs	IM-30 x 2pcs	IM-30 x 3pcs
IEEE 1394 Host controller x 1	30fps/CH	30fps/CH	30fps/CH
IEEE 1394 Host controller x 2	30fps/CH	30fps/CH	30fps/CH

# 2 Hardware Reference

## 2.1 MAVIS IM-30/IM-100

### 2.1.1 Camera Specification

Item	IM-30	IM-100
Image sensor	1/2" CMOS Sensor Micron MT9V403, Pixel size: 9.9um x 9.9um	
Video output pixels	640(H) x 480(V)	
Gain control	0 ~ 12dB setting via communication command	
Power supply	+12VDC normal (Supply via 1394 cable)	
Power consumption	Max. ~ 1.7W at 12V	
Acquisition mode	Free Run (exposure time programmable ), External random trigger	
Connector Interface	6-Pin IEEE 1394 connector(for video and power) 10-Pin GPIO (General Purpose Input/Output)connector	
GPIO connector	TTL level with 2 input, 4 output and one +5VDC output	
Video mode	Initial mode: 640 x 480 at 30fps Scalable mode: by AOI	Initial mode: 640 x 480 at 100fps Scalable mode: by AOI
Protocol	IEEE 1394a version. 1.31 (transfer speed 400Mbps)	
Test image	Gray value internal test pattern generated	
Exposure Time	Programmable via IEEE 1394 bus	
Brightness	Programmable via IEEE 1394 bus	
Temperature	Operating temperature : 0°C ~ 50°C (32°F ~ 122°F) Storage temperature: -20°C ~ 60°C (-4°F ~ 140°F)	
Humidity	Operating humidity : 20% ~ 80%, relative, non-condensing Storage humidity: 10% ~ 90%, relative, non-condensing	
EMC condition	CE/FCC	
Dimension	72.5mm (H) x 49mm(W) x 36.7mm(D) without Lens	
Weight	120g without Lens	
Lens Adaptor	C/CS Mount	

## 2.1.2 Camera Interface

● IEEE 1394		● GPIO	
Pin	Name	Pin	Name
1	+12VDC	1	Output 0
2	GND	2	Input 0
3	TPB-	3	Output 1
4	TPB+	4	Input 1
5	TPA-	5	Output 2
6	TPA+	6	NC
		7	Output 3
		8	NC
		9	GND
		10	NC

Pin	Name
1	+12VDC
2	GND
3	TPB-
4	TPB+
5	TPA-
6	TPA+

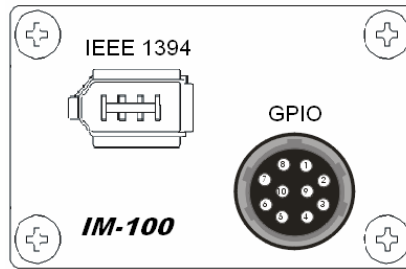

Camera rear view

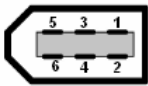

Table 2-1 Camera Interface Connector Pin Assignments

## 2.1.3 Standard Package Contents

Camera with Lens-cap	Driver CD & Installation Guide
	Tripod Adapter with screws
	GPIO Wiring Connector

## 2.2 Optional Accessory

To increase your system's working performance and reliability, ICP DAS suggests three optional accessories.

### 2.2.1 1394 Dual-port Card: IOI-4601-21

The IOI-4601-21 is dual IEEE 1394 host controller PCI interface card. Capable of supporting simultaneous dual ports data transmission at rates of 400Mbps.



Host Bus	32-bit PCI local bus complies with PCI 2.1 and 2.2 specification Use only one IRQ for both OHCI 1.1 channels
Interface Protocol	Bus Master DMA
1394 Bus Transfer Rate	100/200/400 Mbps
Host Bus Burst Data Rate	Up to 133 MB/s burst rate
IEEE-1394 to PCI Chip	2x Ti TSB43AB21
1394 Connector	External X 2 (FW-6pin X 2) OHCI 1 (FW-6pin X 1) OHCI 2 (FW-6pin X 1)
1394 Bus Power Connector	Mini 4-pin DC +12V power connector
Bus Power Connector	with mini 4-pin DC + 12V Power Connector
Performance	Maximum 1394 Bus Transfer is 800 Mbps (400 Mbps per channel)

### 2.2.2 1394 Latch Cable: CA-1394-45

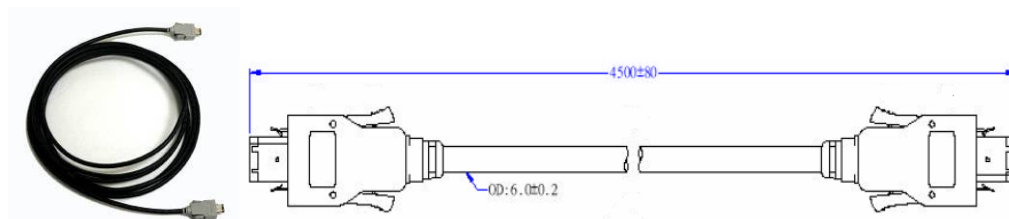

1394 connector	6-pin male connector with spring latch, PVC molding
Cable wiring gauge	UL-20276 cable, 28AWG x 2pairs, 22AWG x 2 conductors. Double shielded.
Length	450mm

### 2.2.3 1394 Repeater: 1394R3B

1394R3B repeater offer 1port to 2 ports IEEE 1394 signal repeat and cable extension need. The 1394R3B allow convert 1394-1995 to 1394a.



Top Side View

Left Side View

Right Side Vide



Chip	PHY: TI. TSB41AB3
1394 Bus Transfer Rate	100 / 200 / 400 Mbps
Device Interface	A 400-Mbps, 2-port, 3.3V PHY
Power Input Range	DC 12V ~ 30V, Max. 1.35A
Connector	6 Contact Male x3 DC - Walkman-type 2.0mm DC Jack x1
Dimension	72mm(W) x 58mm(H) x 20mm(D)





**DC power input ONLY for using Notebook 1394 port or 1394 PCMCIA interface card.**



# 3 Installation Guide

MAVIS IM-30/IM100 IEEE 1394 cameras support operation in IPC, PC and Notebook system platforms. This also installation guide includes information on how to use this camera correctly and safely. Please read through this installation guide carefully and follow the installation steps of your specified system platform.

CAUTION	
	<b>DO NOT open the camera housing in any situation.</b> Touching internal components may damage camera function. Meanwhile when customer to open camera housing then warranty will be void immediately.
	Be careful not to allow liquids, flammable or metallic material inside of the camera.

## 3.1 Hardware Installation

### 3.1.1 IPC/PC Platform

- Some desktop PCs have a built-in 1394 port with 6-pin 1394 connector; if your system is one of these, you will be able to use a 1394 cable connect to your system 1394 port directly.
- If you choose to use an IPC or your desktop PC without a built-in 1394 port, then please see the following steps to install your 1394 interface card on a PCI bus:
  - (1) Remove the computer cover using the instructions from the computer manual.
  - (2) Check that there is an empty PCI (32-bit) slot to accommodate the card.
  - (3) Remove the blank metal plate located at the back of the selected slot (if any). Keep the removed screw to fasten the 1394 card after installation.
  - (4) Carefully position the 1394 card in the selected PCI slot as illustrated below. If using a tower computer, orient the board to suit the board slots.

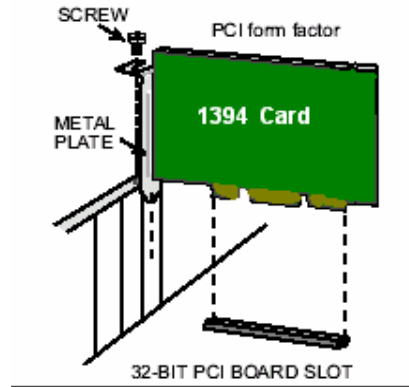

- (5) Once perfectly aligned with an empty slot, press the card firmly but carefully in to the connector.
- (6) Anchor the board by replacing the screw.
- (7) Using 1394 cable to connect MAVIS IM-30/IM-100 1394 camera to 1394 card and GPIO cable wiring if necessary. For image acquisition test please refer to the “EZView Utility”.



- (8) Turn on the system and you will be able to find the 1394 Host controller device with Device Manager.
- (9) If you need to extend your working distance, please using 1394 repeater directly.



	<p><b>DO NOT input DC power to 1394 repeater when using IPC/PC platform. The DC power input may damage your 1394 card or 1394 host controller circuit.</b></p>
---	--

### 3.1.2 Notebook PC / PCMCIA Socket

- If your notebook PC has an iLink/S400 interface port then your notebook PC has a built-in 1394 host controller. So please follow the steps for installation.



- (1) Please prepare one IEEE 1394 repeater, one 4-pin to 6-pin IEEE 1394 cable, one 6-pin to 6-pin IEEE 1394 cable and one walkman type DC power adaptor first.



- (2) Please use 4-pin to 6-pin IEEE 1394 cable and 4-pin connector to iLink/S400 interface port and 6-pin connector to 1394 repeater.



- (3) When 6-pin connection to 1394 repeater, then please plug in DC power adaptor and another 6-pin to 6-pin 1394 cable.

- (4) 6-pin to 6-pin 1394 connected to MAVIS IM-30/IM-100 IEEE 1394 port and GPIO wiring connection if necessary.



- If your notebook PC does not have a 1394 interface port, then please plug your 1394 Card Bus to PCMCIA socket, and follow the steps for installation.



- (1) Please prepare one IEEE 1394 PCMCIA card, IEEE 1394 repeater, two 6-pin to 6-pin IEEE 1394 cable and one walkman type DC power adapter first.



- (2) Plug IEEE 1394 PCMCIA card to Notebook PCMCIA socket as below.



- (3) Plug 6-pin connector to IEEE 1394 PCMCIA card and another 6-pin connected to IEEE 1394 repeater.



- (4) When 6-pin connection to 1394 repeater is established, please plug in DC power adaptor and another 6-pin to 6-pin 1394 cable.

- (5) 6-pin to 6-pin 1394 connected to MAVIS IM-30/IM-100 IEEE 1394 port and GPIO wiring connection if necessary.



## 3.2 Driver Installation

Do not plug in any MAVIS IM-30/IM-100 cameras before driver installation has been completed. Please refer to the following installation steps for various programming environment specific installations.

### 3.2.1 For Visual Studio (VC/VB/BCB/VC#.NET) Users

1. Insert the MAVIS Support CD to CD-ROM/DVD-ROM drive.
2. The MAVIS Support CD will start to prepare driver installation as below.

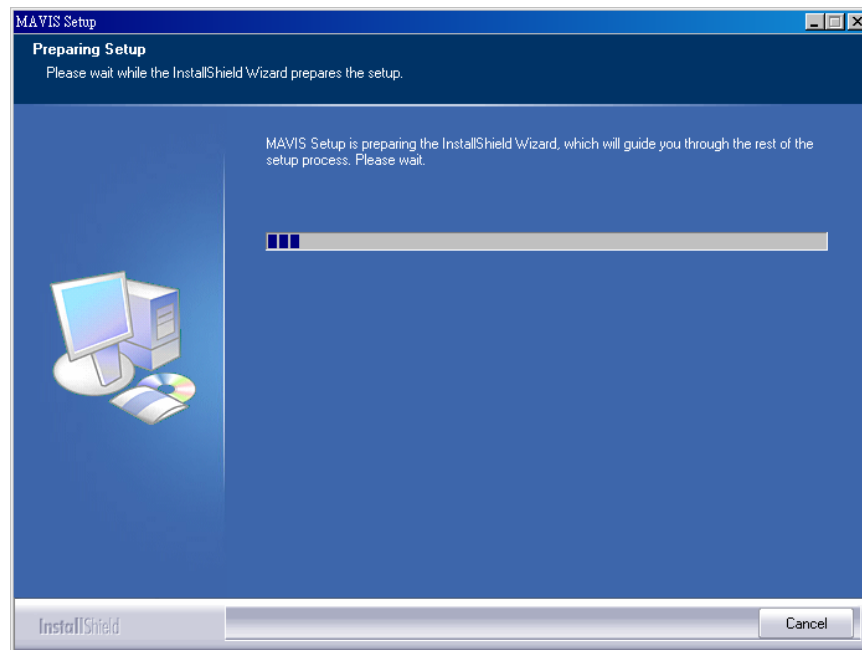

3. Please click "Next" button for driver installation.

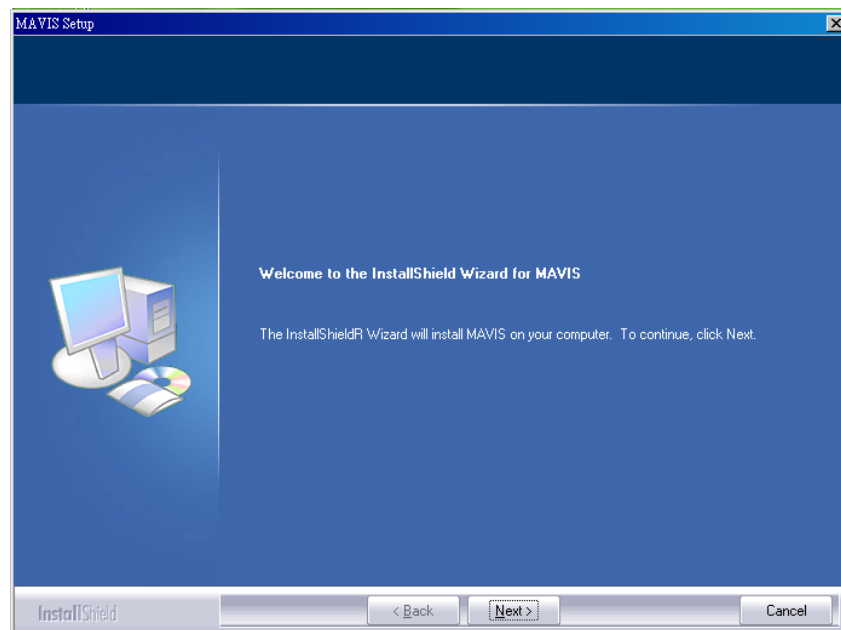

4. Please enter user name and company name, then click “Next” button.

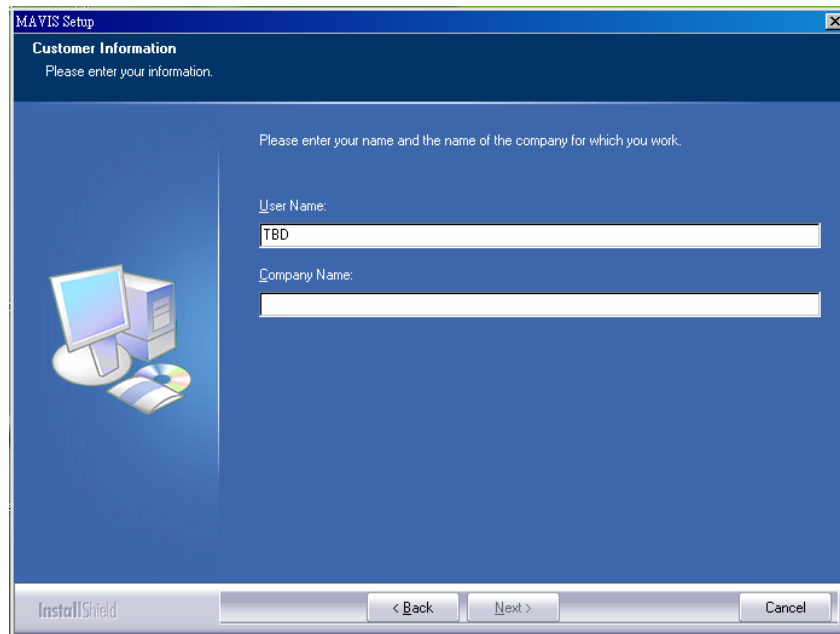

5. The MAVIS series default path located at C:\MAVIS\, and you can click “Change..” button to change driver installation path, otherwise please click “Next” button for continue driver installation.

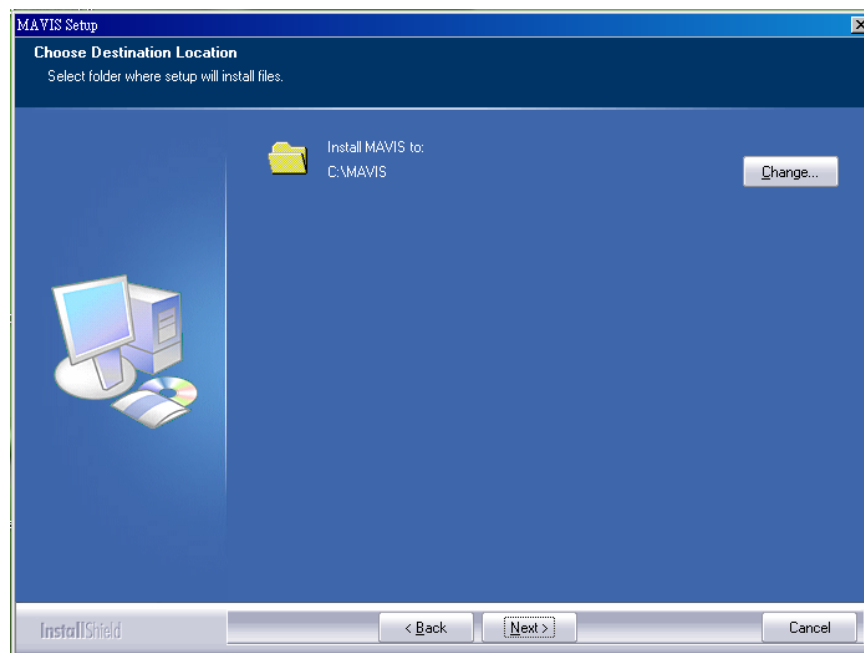

6. Please click the "Install" button

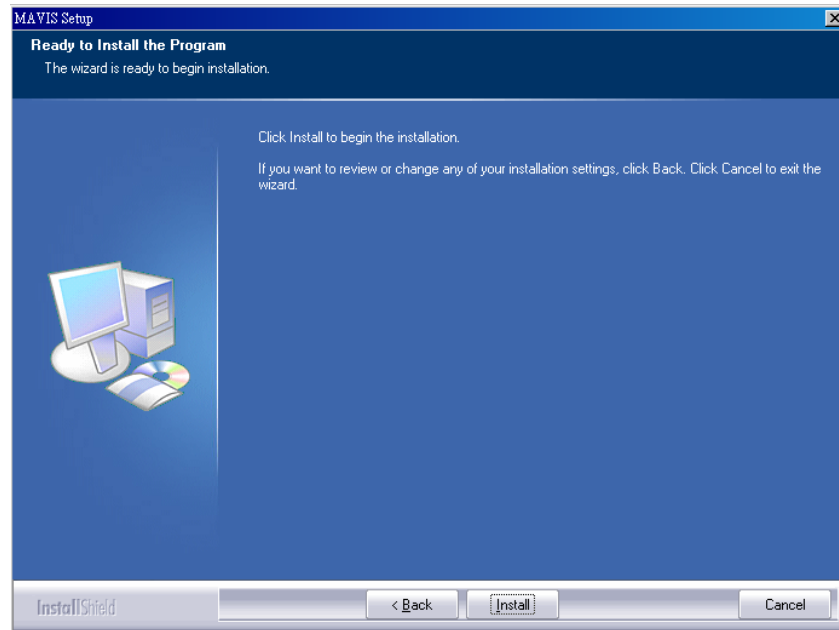

7. Driver installing

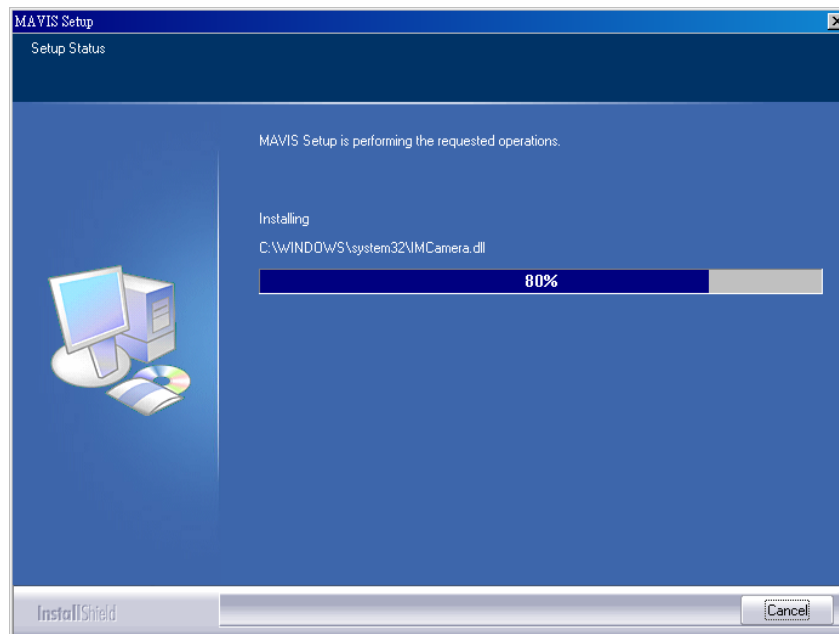

- When driver install is completed, please click the “Finish” button and restart your system.

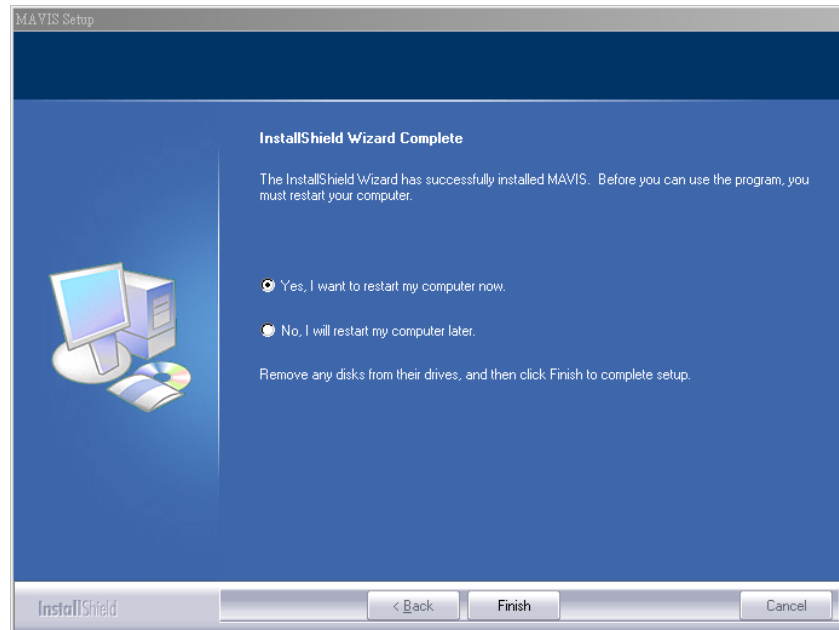

- After system re-boot, please plug in the MAVIS IM-30/IM-100 cameras and go to “Device Manager” and make sure you see the “Generic IEEE-1394 digital camera” in the list of “ICP DAS MAVIS”.

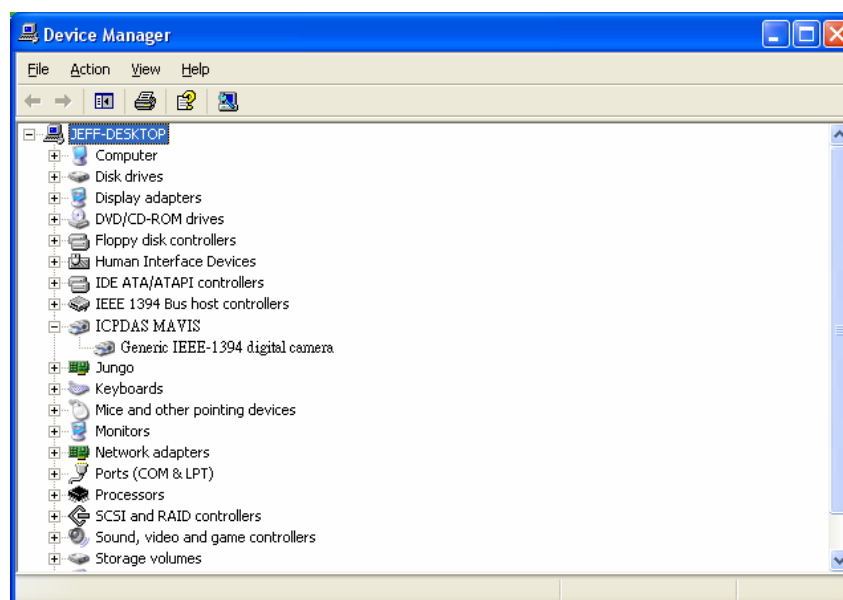

- If your system had install other vendor’s 1394 camera driver, then you may need to remove it and change to install MAVIS driver by manually.
- When the installation has been completed, open “EZView” utility for image acquisition testing, please refer to “4. EZView Utility” for details.





### 3.2.2 For LabVIEW Users

If you prefer to use LabVIEW from NI (National Instruments) for your system development, then we'll suggest you to use NI-IMAQ directly.

The MAVIS IM-30/IM-100 series are fully compatible with NI-IMAQ-1394. Please just select "NI-IMAQ IEEE 1394 IIDC Digital Camera" driver for your installation and DO NOT install the MAVIS driver.

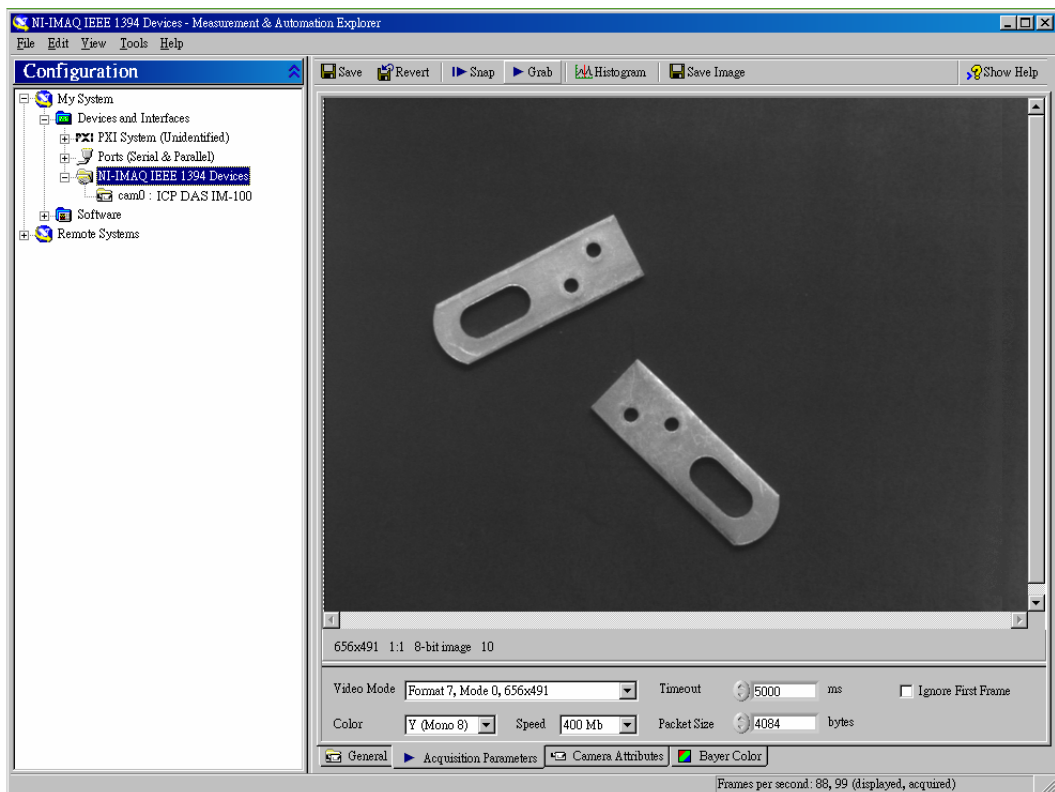
After installation is completed, then you can use "Measurement & Automation Explorer" of NI for configuration of the camera and the image grab test.



	<p><b>When you install the NI-IMAQ-1394 driver, all MAVIS official drivers, API and EZView utilities will fail to work.</b></p>
---	---

# 4 EZView Utility

Once hardware installation is complete, ensure that cameras are configured correctly in Device Manager before running the EZView utility. This chapter outlines how to establish a vision system and how to manually control the MAVIS IM-30/IM-100 camera series to verify correct operation. EZView provides a simple yet powerful means to setup, configure, test, and debug the vision system.

**Note:** EZView is only available for Windows 2000/XP with a recommended screen resolution higher than 1024 x 768.

## 4.1 Overview

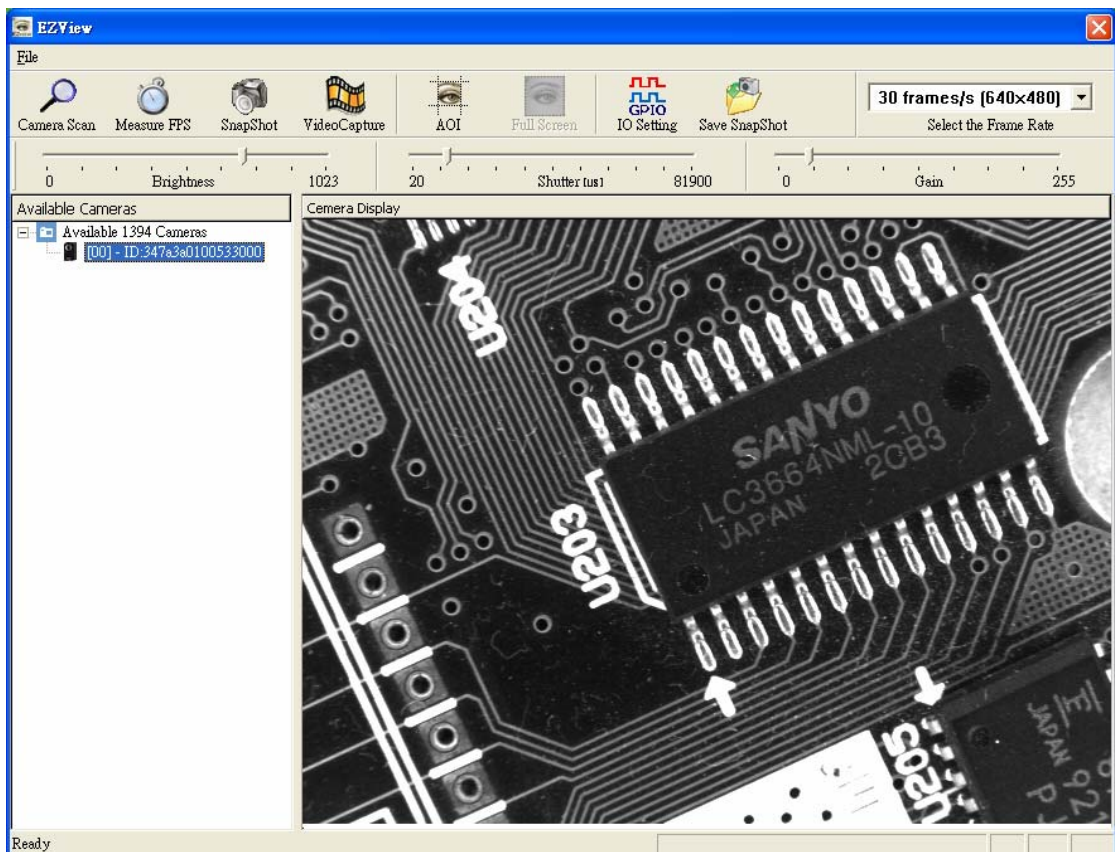
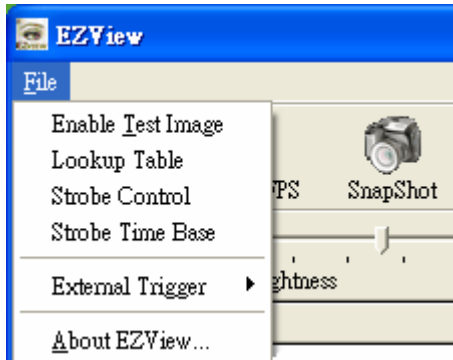

Figure 4-1: EZView Utility Main Screen

## 4.2 Component Description

### ■ File

The File menu offers the “Enable Test Image”, “Lookup Table”, “Strobe Control”, “Strobe Time Base”, “External Trigger” functions and “About EZView” for version control information as below.



### Test Image Mode

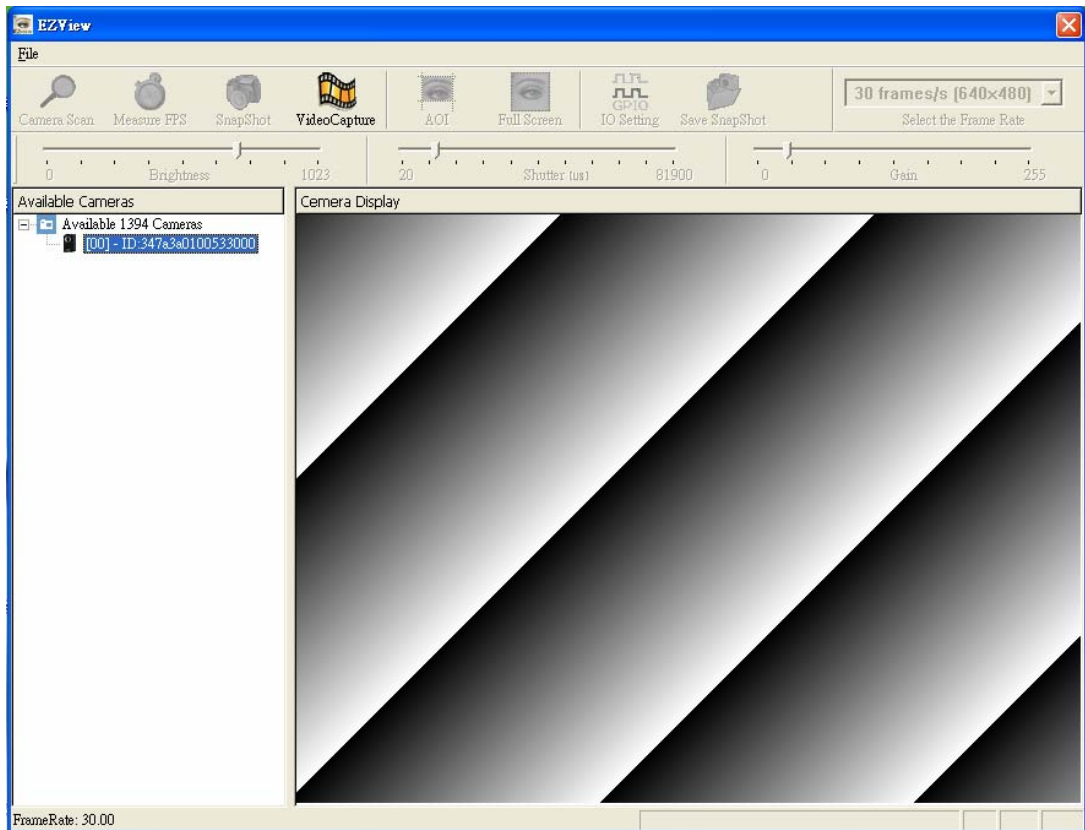

### Lookup Table

The EzView utility has offer interface window for user to 'Download' the LUT information of MAVIS. Meanwhile, user can enable the 'Enable LUT' function for 'Upload' custom LUT information to MAVIS operation.

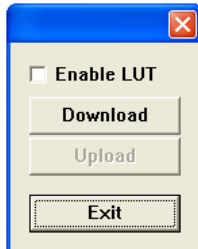

### Strobe Control

The EzView utility offer interface window for Strobe Control parameter setting and those parameters only effective when configure the specific output port for strobe operation.

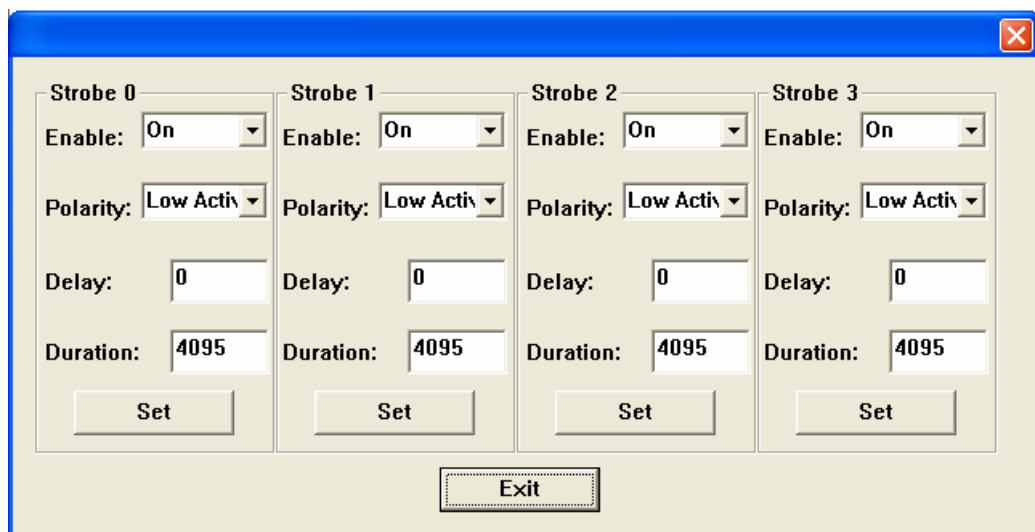

### Strobe Time Base

This is for change strobe control Duration Time Base. The Duration Time Base range from 1 ~ 85 and the time base denominator is 1/1024ms. For example, when Strobe Duration value is 600 and set the Duration Time Base to 50, then the strobe light up duration time will be:  $600 \times (50/1024\text{ms}) = 24.4\text{ms}$ .

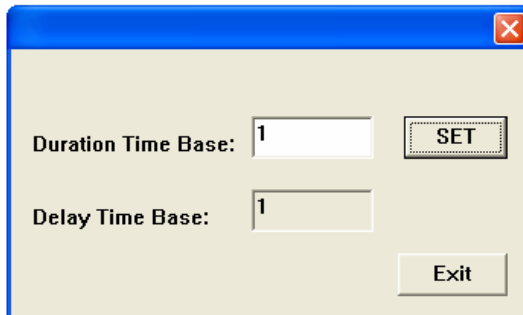

### External Trigger



“External Trigger” function menu.

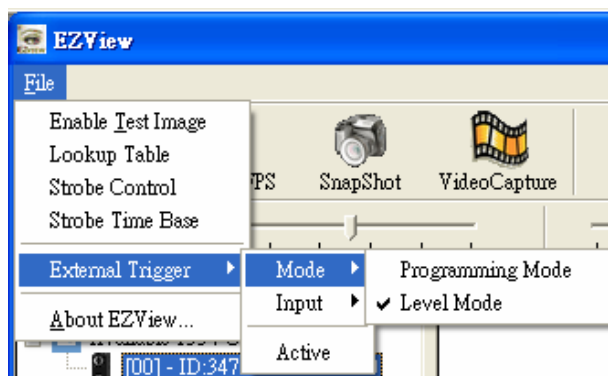

“External Trigger” function has offer two exposure control setting, include: “Programming Mode” and “Level Mode”.

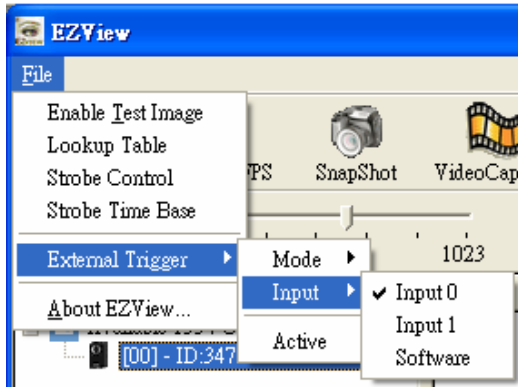

“External Trigger” has offer two hardware trigger control by “Input 0” and “Input 1” and “Software” trigger control.

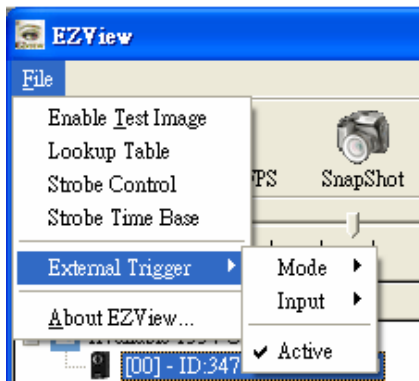

All “External Trigger” function parameters only effective when “External Trigger” function is setting to “Active”.

### About EZView

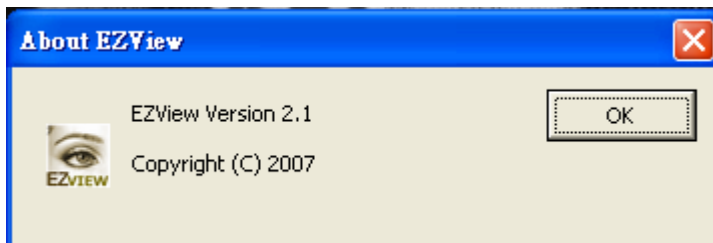

## ■ Tree Browser

The Tree Browser window lists the 1394 Host controller ports and how many MAVIS 1394 cameras are available at the local computer.







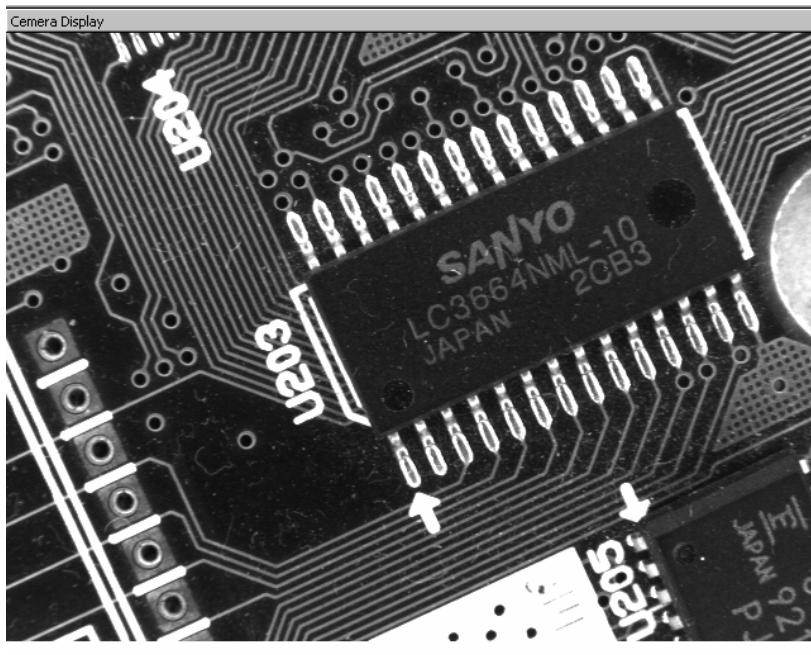



## ■ Display Window

The display window displays full and specifically requested AOI size images and image effects.



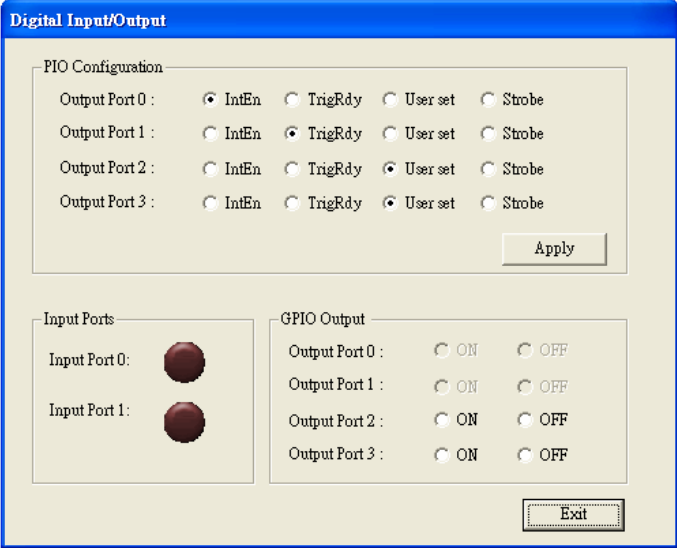

■ **Tool Icons**

	<p><b>Camera Scan</b></p> <p>Click the Camera Scan icon to list the MAVIS 1394 cameras available at the local computer.</p>
	<p><b>Measure FPS</b></p> <p>Click the Measure FPS icon and a pop-up will show the result of the frames per second test</p>
	<p><b>Snap Shot</b></p> <p>Click the SnapShot icon. A single image will appear in the Display Window</p>
	<p><b>Video Capture</b></p> <p>Click the Video Capture icon. A video frame will appear in the Display window</p>
	<p><b>AOI</b></p> <p>Clicking the ROI icon will allow using the mouse to select the area of interest within the image.</p>
	<p><b>Full Screen</b></p> <p>Clicking the Full Screen icon will disable the AOI function and re-size the display to the default, full resolution: 640 x 480.</p>
	<p><b>IO Setting</b></p> <p>Click the IO Setting icon to bring up the GPIO dialog box. Select the port to access and select the digital input / output setting.</p>
<p><b>IO Setting Screen</b></p> 	
	<p><b>Save Snap Shot</b></p> <p>Click Save Snap Shot icon to save current single image to a BMP file.</p>

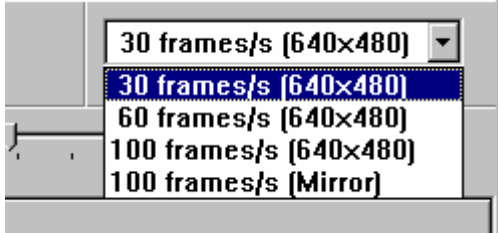

■ **Control bar**

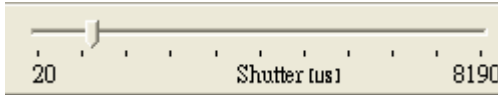
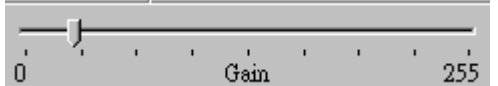
	<p><b>Select the Frame Rate</b></p> <p>The EZView utility offers 30fps acquisition speed for default demonstration. Selection of the Frame Rate control bar is only available while using the MAVIS IM-100.</p>
	<p><b>Brightness</b></p> <p>Click and hold the left mouse button on the Brightness slider and drag the cursor to change its value. Values range from 0-1023.</p>
	<p><b>Shutter</b></p> <p>Click and hold the left mouse button on the Shutter slider and drag the cursor to change its value. The shutter speed range from 20us to 81900us. ( 0.02ms ~ 81.9ms)</p>
	<p><b>Gain</b></p> <p>Click and hold the left mouse button on the Gain slider and drag the cursor to change its value. Values range from 0 to 255.</p>

# 5 EzVIEW\_Fly Utility

The EzVIEW\_Fly is a friendly utility designed for ICPDAS machine automation customer. The EzVIEW\_Fly utility now supported PISO-PS400 (driver version 3.0), ET-M8194H (driver version 1.0) and FRNET I/O. User can very easily to setup, configure, test, and debug about MAVIS cameras image acquisition by external hardware trigger in EzVIEW\_Fly utility.

This chapter outlines how to establish a vision with motion control system and how to setting the correct functions and parameters for I/O trigger, trigger compare or random trigger to verify correct operation.

**Note:** EzVIEW\_Fly is only available for Windows 2000/XP with a recommended screen resolution higher than 1024 x 768.

## 5.1 Overview



Figure 5-1: EzVIEW\_Fly Utility Main Screen

## 5.2 Configuration

The Configuration included Feature Setting, Advanced Feature and I/O Setting.

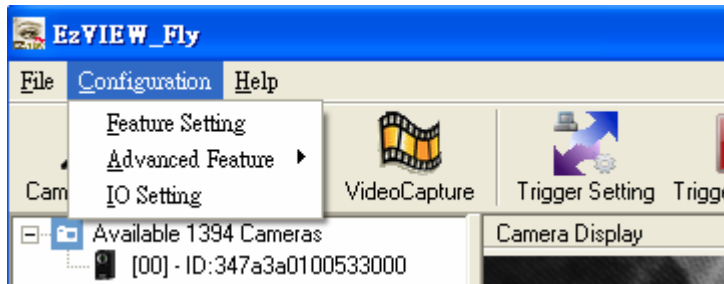

### ■ Feature Setting

The Main Feature Setting window included features setting for MAVIS Camera and Motion Module products. Please refer 5.2.1 and 5.2.2 for detail information.

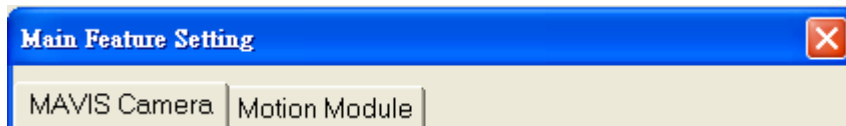

### ■ Advanced Features

The Advanced Feature included Test Image and Lookup Table functions of MAVIS and please refer Chapter 4 EZView utility for the operation description.

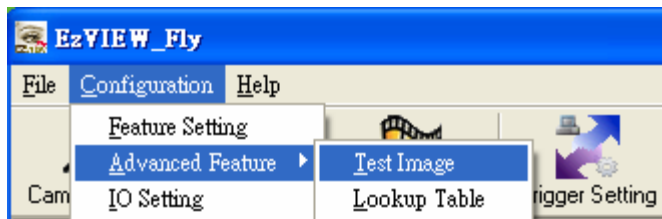

### ■ I/O Setting

The I/O Setting function offer the interface window same with EZView utility and please just refer Chapter 4 EZView utility for the operation description.

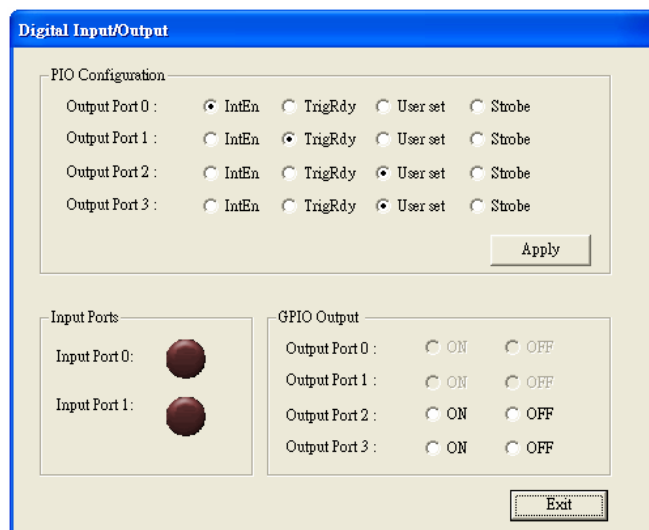

## 5.2.1 Feature Setting of MAVIS Camera

The MAVIS Camera included MAVIS Main Feature, ROI Setting and Trigger Setting function and user can refer the operation as Chapter 4 EZView utility. Meanwhile user must to click 'Apply' button for save your setting into the MAVIS.

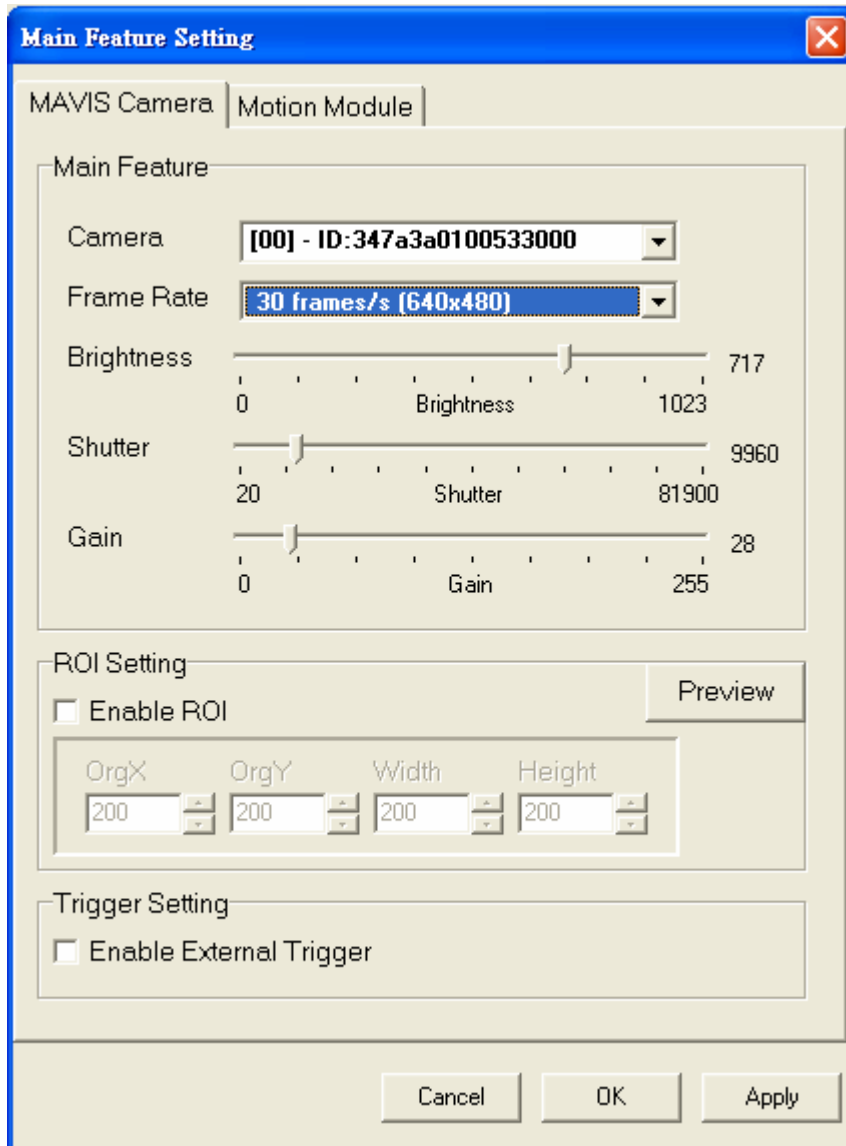

In this page the 'Enable External Trigger' function of Trigger Setting, it is only for MAVIS trigger input (by TTL signal voltage) port used and no matter with any motion trigger pulse.

## 5.2.2 Feature Setting of Motion Module

The Motion Module now supported ET-M8194H and PISO-PS400, and each time user only can choose one product model for motion control feature setting and single axis operation.

	<p><b>EzVIEW_Fly utility required ET-M8194H or PISO-PS400 for hardware trigger pulse operation. For hardware installation, please follow the description of ET_8194H_QuickStart or PISO-PS400_Getting_Started for operation correctly.</b></p>
---	--

### ■ Main Feature Setting of Motion Module

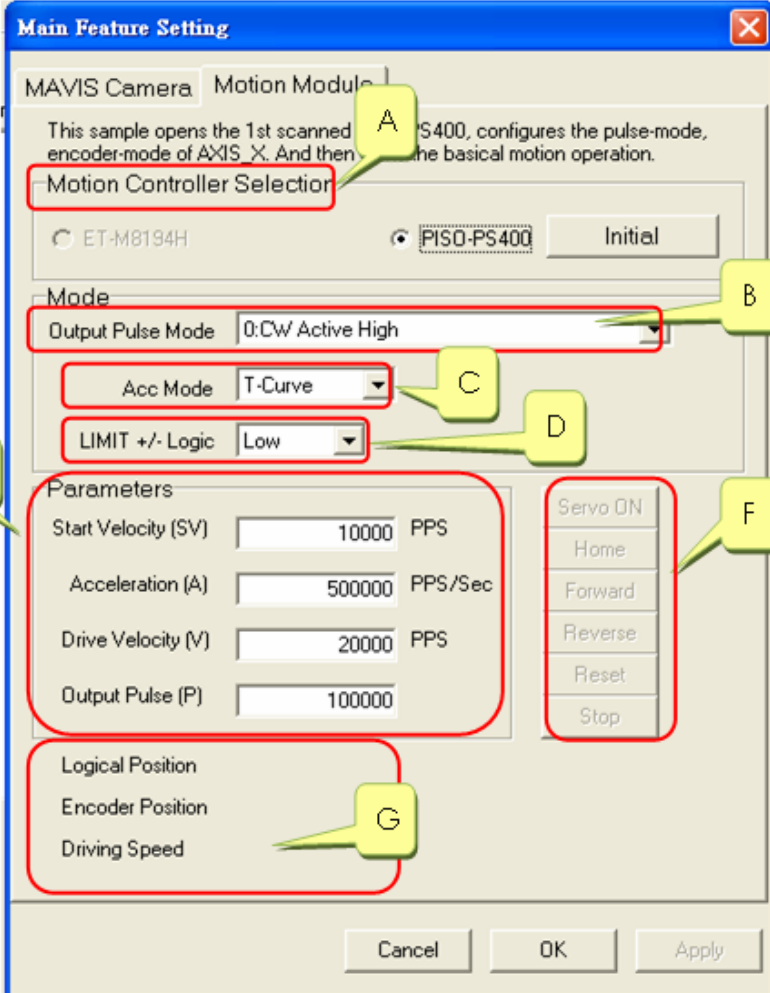

Regarding the parameters meaning, please refer the ET\_8194H\_QuickStart or PISO-PS400\_Getting\_Started for detail information.

Area	Functionality	Parameters
<b>A</b>	Motion Controller Selection	ET-M8194H · PISO-PS400
<b>B</b>	Output Pulse Mode	CCW · PULSE DIR

<b>C</b>	Acceleration Mode	T-Curve · S-Curve · Constant
<b>D</b>	Limitation +/- Logic	High · Low
<b>E</b>	Parameters	Start Velocity · Acceleration Velocity · Driving Velocity · Output Pulse
<b>F</b>	Operation Command	Servo On/Off · Home* · Forward · Reverse · Reset · Stop
<b>G</b>	Read Status	Logical Position · Encoder Position · Driving Speed

Home\* - user must install limitation sensor for home operation.

### ➤ When choose ET-M8194H

When choose ET-M8194H then please input your ET-M8194H IP address and click 'Connection' button for Ethernet connection.

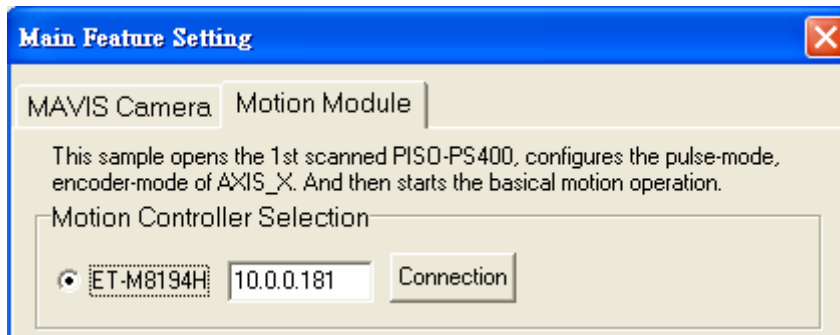

User can use EzMove utility of ET-M8194H for IP address configuration or detail function operation. (Please refer the user manual of ET-M8194H).

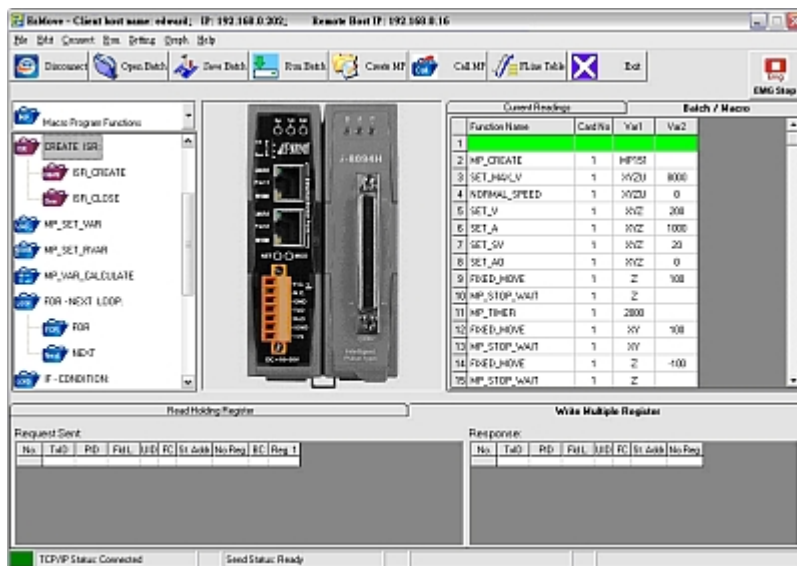

### ➤ When choose PISO-PS400



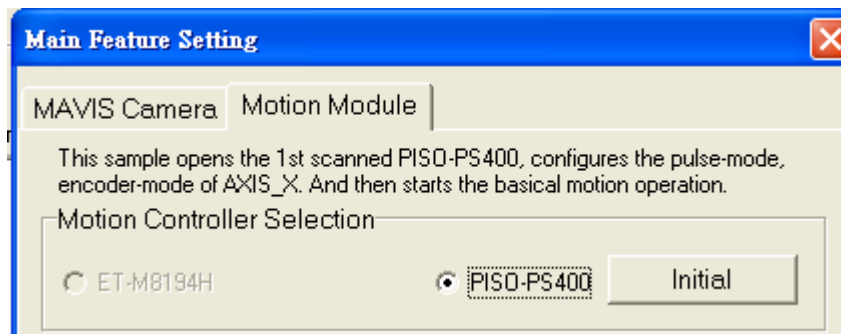



Please click 'Initial' button for PISO-PS400 card initialization. This is only work in PISO-PS400 driver 3.0 and operation for AXIS\_X only.



### 5.3 Help – About EzVIEW\_Fly



### 5.4 Tool Icons

	<b>Camera Scan</b> Click the Camera Scan icon to list the MAVIS 1394 cameras available at the local computer.
	<b>Snap Shot</b> Click the SnapShot icon. A single image will appear in the Display Window
	<b>Video Capture</b> Click the Video Capture icon. A video frame will appear in the Display window
	<b>Trigger Setting</b> Click the Trigger Setting icon to bring up the MAVIS and Motion trigger function setting screen as 5.4.1 description.
	<b>Trigger Capture</b> Clicking the Trigger Capture icon. The image will appear in the Display while MAVIS received the external trigger.
	<b>Trigger Stop</b> Clicking the Trigger Stop icon will disable the Trigger Capture function.

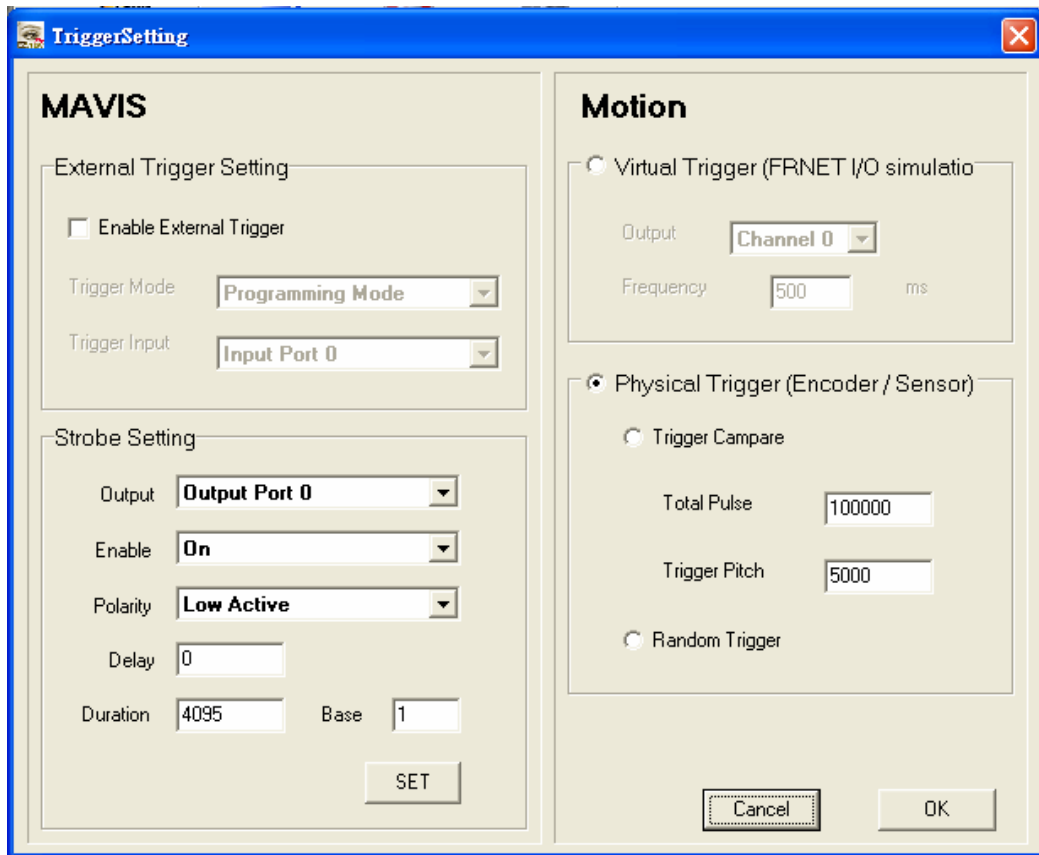

## 5.4.1 Trigger Setting







### ■ MAVIS

External Trigger Setting	
<input checked="" type="checkbox"/> Enable External Trigger	The check box must enable for trigger capture.
Trigger Mode: Programming Mode	Selected the Trigger Mode and user can refer 1.4.8 for external trigger mode detail information.
Trigger Input: Input Port 0	Selected the Trigger Input port and ensure the wiring correctly.
Strobe Setting	
Output: Output Port 0	Selected output port and ensure the wiring correctly.
Enable: On	Selected 'On' for enable the strobe control function.

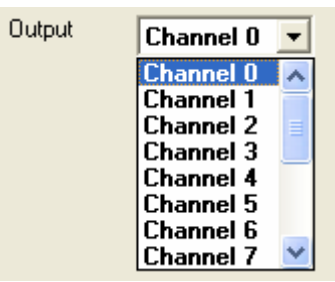

	<p>Selected the active polarity mode and user can refer 1.4.9 for Strobe Control polarity definition.</p>
	<p>Setting the delay value in necessary and please refer 1.4.9.for the formula of delay time.</p>
	<p>Setting the strobe duration and time base and please refer 1.4.9 for the formula of duration time.</p>

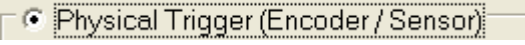
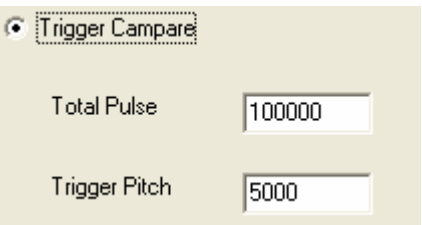
■ **Motion**

<p><b>Virtual Trigger</b></p>	
	<p>Enable the check box while used FRNET for I/O trigger simulation.</p>
	<p>Selected the output port of FRNET and ensure the wiring correctly.</p>
	<p>Setting the trigger pulse frequency of FRNET.</p>
<p><b>Physical Trigger</b></p>	
<p>Note – Please refer the Hardware Installation of PISO-PS400 or ET-M8194H for the wiring of motion in position signal output to MAVIS trigger input port.</p>	
	<p>Enable the check box while used PISO-PS400 or ET-M8194H for received the in position signal from encoder / sensor.</p>
	<p>Enable the check box of Trigger Compare and setting the Total Pulse and Trigger Pitch for equidistance trigger.</p>
	<p>Enable the check box while active the trigger pulse in randomized.</p>

# 6 Function Library

This chapter describes the API for MAVIS IM-30/IM-100 cameras. Users can use these functions to develop application programs under Visual C++ 6.0, Visual Basic 6.0 , Boland C++ Builder 6.0, and C#.NET 2003.

The MAVIS DLL file (IMCamera.dll) is common to use in Visual C++, Visual Basic, Boland C++ Builder and C#.NET development language.

For Visual C++ and Boland C++ Builder, please just follow standard Syntax description to use.

For Visual Basic, we have offer "IMCamera.bas" module file in our sample program and user also can define or modify function module file as you need.

For C#.NET, we have defined a class "Mavis" in our sample program and we are strong to recommend that user can build own class as you need.

For example:

```
public class Mavis
{
    [DllImport("IMCAMERA.DLL")]
        public static extern short IMC_Camera_Scan(out IMC_DEVICE_DATA
        pCamera_List);
    [DllImport("IMCAMERA.DLL")]
        public static extern short IMC_Camera_Init( int camera_idx, ref IntPtr pHandle );
    [DllImport("IMCAMERA.DLL")]
        public static extern short IMC_FrameRate_Set( IntPtr Camera_Handle, ulong
        FrameRate, bool bMirror );
    [DllImport("IMCAMERA.DLL")]
        public static extern short IMC_Camera_Close( IntPtr Camera_Handle );
    ...
}
```

Please refer to Table 6-1 List of Functions for functions by category. All the data types follow Microsoft standard definitions.

## 6.1 List of Functions

Category	Section	Function
Camera Management	5.2	IMC_Camera_Scan
		IMC_Camera_Init
		IMC_Camera_Close
Camera Acquisition	5.3	IMC_ImageAcquisition_Start
		IMC_Image_Acquire
		IMC_ImageAcquisition_Stop
		IMC_AcquisitionFrame_Copy
		IMC_AcquisitionFrame_Save
		IMC_Live_Acquire
		IMC_LiveAcquisition_Stop
Camera Configuration	5.4	IMC_FrameRate_Set
		IMC_Shutter_Get
		IMC_Shutter_Set
		IMC_Gain_Get
		IMC_Gain_Set
		IMC_Brightness_Get
		IMC_Brightness_Set
Digital Input/Output	5.5	IMC_OutputPort_Status
		IMC_OutputPort_Configure
		IMC_OutputPort_Write
		IMC_InputPort_Read
		IMC_InputPort_ReadAll
External Trigger	5.6	IMC_Trigger_Enable
		IMC_Trigger_Disable
		IMC_Trigger_ReadConfiguration
Strobe Control	5.7	IMC_StrobeControl_SetConfiguration
		IMC_StrobeControl_ReadConfiguration
		IMC_StrobeTimeBase_SetDurationTime
		IMC_StrobeTimeBase_ReadConfiguration
Look Up Table	5.8	IMC_LUT_Read
		IMC_LUT_SetStatus
		IMC_LUT_ReadStatus
		IMC_LUT_Write
AOI (Area of Interest)	5.9	IMC_AOI_Configure
Advanced Features	5.10	IMC_TestImage_Enable
		IMC_TestImage_Disable

**Table 5-1: List of Functions**

## 6.2 Programming Flowchart

- *Camera scan & initial*

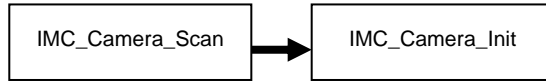

- *Camera close*

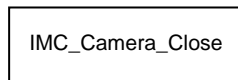

- *Camera parameters setting*

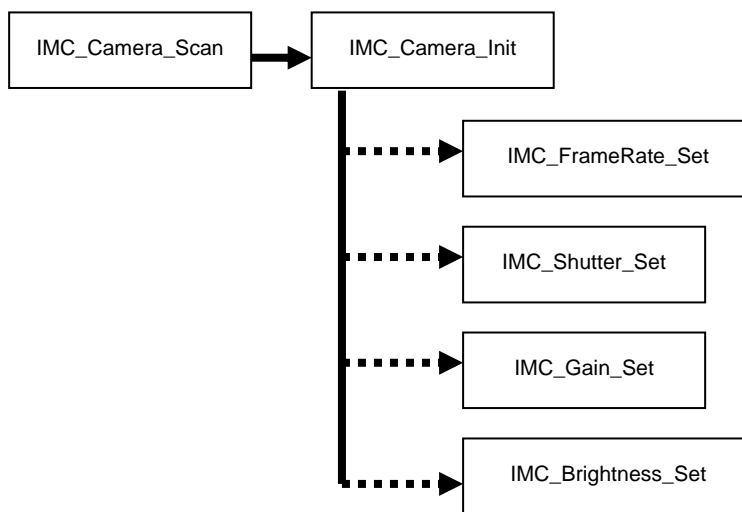

- *Check camera setting*

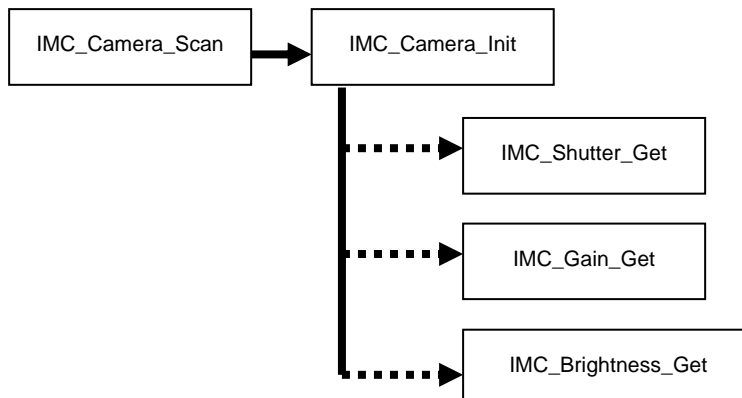

- *Snapshot*

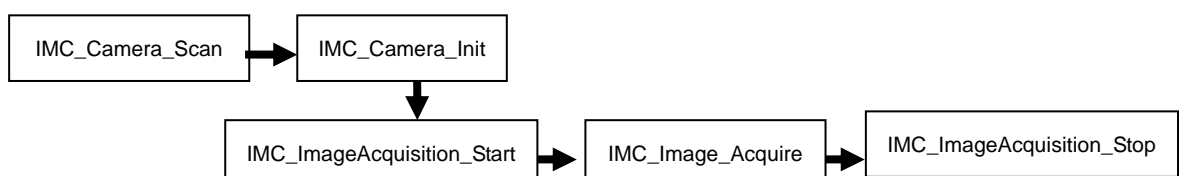

- **Live continue images capture**

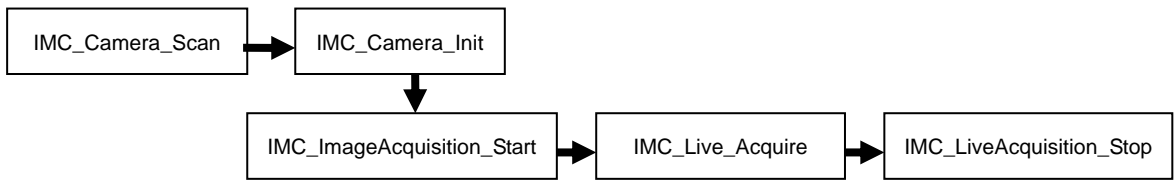

- **Save single image to BMP file**

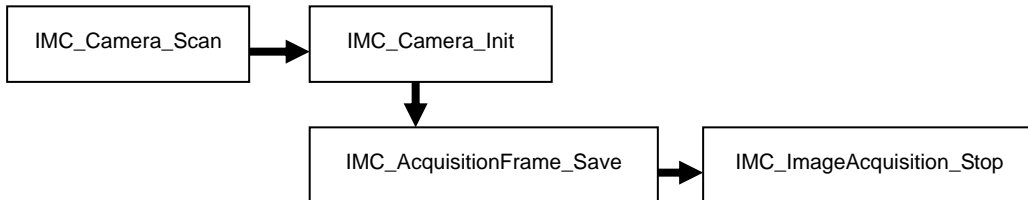

- **Copy image to memory buffer**

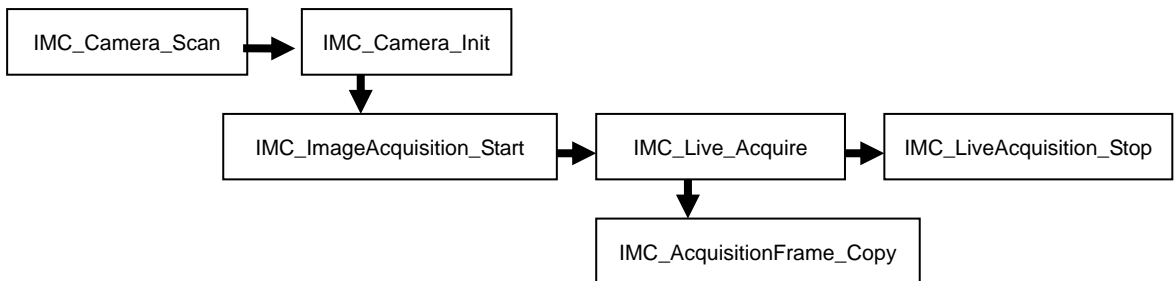

- **External trigger for image acquisition**

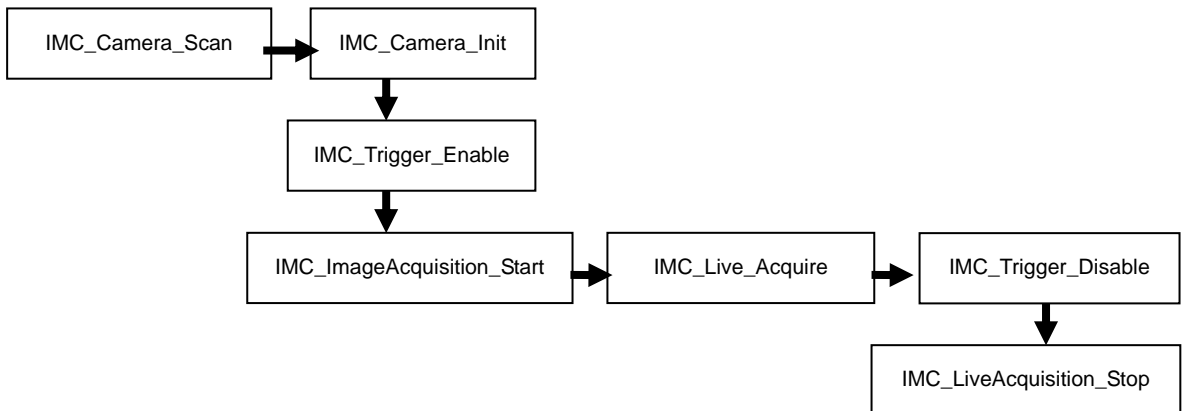

- **Camera digital output setting**

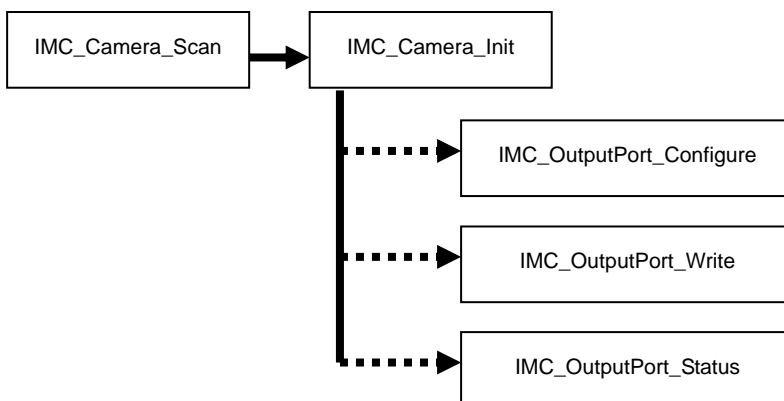

- **Strobe control**

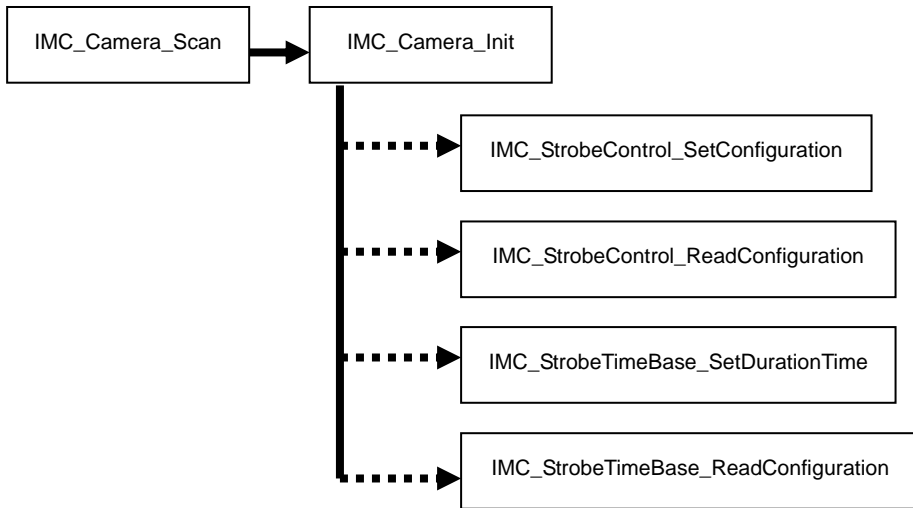

- **Check camera digital input**

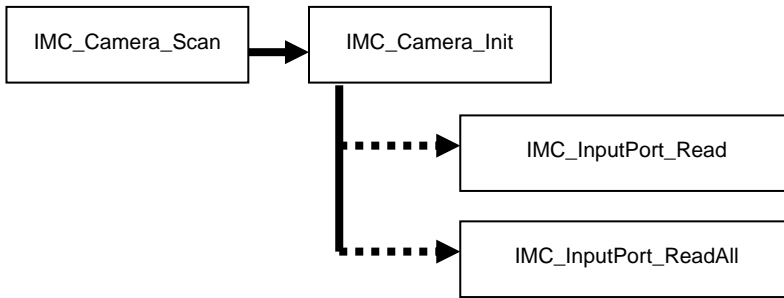

- **Camera AOI setting**

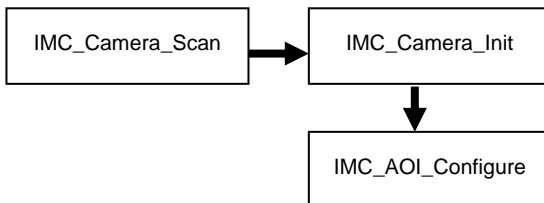

- **Camera test image**

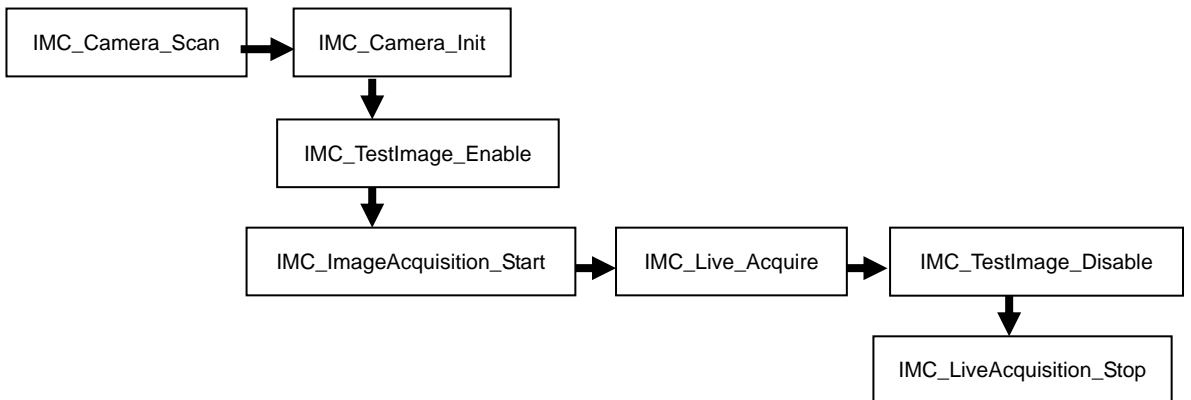

- ***Read camera Lookup Table***

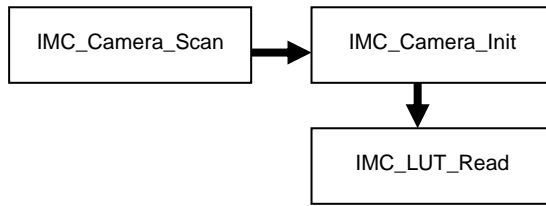

- ***Modify camera Lookup Table***

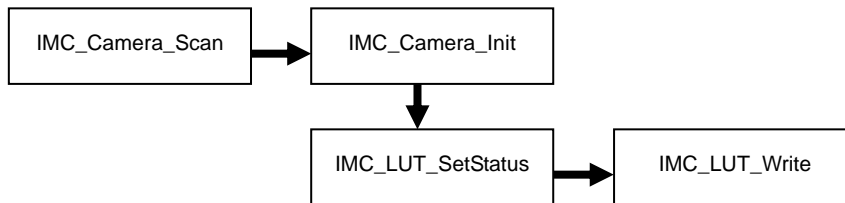

## 6.3 Camera Management

*IMC\_Camera\_Scan*

### Syntax:

#### Visual C++ 6.0 / Boland C++ Builder 6.0:

*short IMC\_Camera\_Scan ( PIMC\_DEVICE\_DATA pCamara\_List);*

#### Visual Basic 6.0

*IMC\_Camera\_Scan (pCamera\_List As IMC\_DEVICE\_DATA) As Integer*

#### C#.NET 2003

*Mavis.IMC\_Camera\_Scan(out IMC\_DEVICE\_DATA pCamera\_List);*

### Description:

This function scans all available MAVIS cameras in system. After this function returns, this structure contains all available MAVIS cameras in system.

### Parameters:

*pCamera\_List*     The pointer to the IMC\_DEVICE\_DATA structure.

### Return:

*ERROR\_SUCCESSFUL*     Successfully  
*ERROR\_NO\_CAMERA*     No MAVIS camera available in system



## *IMC\_Camera\_Init*

### **Syntax:**

#### **Visual C++ 6.0 / Boland C++ Builder 6.0:**

*short IMC\_Camera\_Init ( int camera\_idx, HANDLE\* pHandle);*

#### **Visual Basic 6.0**

*IMC\_Camera\_Init (ByVal camera\_idx As Long, ByRef pHandle As Long) As Integer*

#### **C#.NET 2003**

*Mavis.IMC\_Camera\_Init( int camera\_idx, ref IntPtr pHandle );*

### **Description:**

This function initializes the MAVIS cameras and returns a handle for the other functions. The function is required to enable and start one MAVIS camera. The initialized state will be maintained until calling IMC\_Camera\_Close().

### **Parameters:**

*camera\_idx* The index based on the IMC\_DEVICE\_DATA structure returned by IMC\_Camera\_Scan()

*pHandl* : The pointer to the MAVIS camera. This handle will be needed by other functions.

### **Return:**

<i>ERROR_SUCCESSFUL</i>	Successfully
<i>ERROR_INVALID_IDX</i>	The index is not in valid range (1 to scanned cameras).
<i>ERROR_DEVICE_OCUPPIED</i>	The camera is used by other application.
<i>ERROR_NO_CAMERA</i>	No MAVIS camera response to the initialization command.
<i>ERROR_DEVICE_INIT</i>	Fail to initialize the camera
<i>ERROR_VIDEOFORMAT_SET</i>	Fail to set the DEFAULT_VIDEO_FORMAT
<i>ERROR_VIDEOMODE_SET</i>	Fail to set the DEFAULT_VIDEO_MODE
<i>ERROR_FRAMERATE_SET</i>	Fail to set the DEFAULT_VIDEO_FRAME_RATE
<i>ERROR_CAMERA_CREATE</i>	Fail to create the camera structure.

## *IMC\_Camera\_Close*

### **Syntax:**

#### **Visual C++ 6.0 / Boland C++ Builder 6.0:**

*short IMC\_Camera\_Close ( HANDLE Camera\_Handle);*

#### **Visual Basic 6.0**

*IMC\_Camera\_Close (ByVal Camera\_Handle As Long) As Integer*

#### **C#.NET 2003**

*Mavis.IMC\_Camera\_Close( IntPtr Camera\_Handle );*

### **Description:**

This function releases the allocated resources and closes the MAVIS camera. Once the camera is released by `IMC_Camera_Close()`, the other functions cannot access that camera.

### **Parameters:**

*Camera\_Handle*      The handle for MAVIS camera, use the handle gotten from the '**pHandle**' parameter of `IMC_Camera_Init()`.

### **Return:**

<i>ERROR_SUCCESSFUL</i>	Successfully
<i>ERROR_DEVICE_UNINIT</i>	The specific camera has not been initialized
<i>ERROR_INVALID_CAMERA</i>	The handle is invalid
<i>ERROR_1394FUNC_INCORRECT</i>	The error caused by port incorrect operation
<i>ERROR_CAMERA_CREATE</i>	Fail to create the camera structure

## 6.4 Camera Acquisition

*IMC\_ImageAcquisition\_Start*

### Syntax:

#### Visual C++ 6.0 / Boland C++ Builder 6.0:

*short IMC\_ImageAcquisition\_Start ( HANDLE Camera\_Handle);*

#### Visual Basic 6.0

*IMC\_ImageAcquisition\_Start (ByVal Camera\_Handle As Long) As Integer*

#### C#.NET 2003

*Mavis.IMC\_ImageAcquisition\_Start( IntPtr Camera\_Handle );*

### Description:

This function starts the Image Acquisition. The camera needs be initialized with *IMC\_Camera\_Init()*.

### Parameters:

*Camera\_Handle*      The handle for MAVIS camera, use the handle gotten from the '**pHandle**' parameter of *IMC\_Camera\_Init()*.

### Return:

<i>ERROR_SUCCESSFUL</i>	Successfully
<i>ERROR_CAMERA_CREATE</i>	The Camera_Handle is NULL.
<i>ERROR_DEVICE_UNINIT</i>	The specific camera has not been initialized.
<i>ERROR_INVALID_CAMERA</i>	The handle is invalid.
<i>ERROR_1394FUNC_INCORRECT</i>	The error caused by port incorrect operation.
<i>ERROR_ACQUIMAGE_START</i>	Fail to start the image acquisition.

## *IMC\_ImageAcquire*

### **Syntax:**

#### **Visual C++ 6.0 / Boland C++ Builder 6.0:**

*short* IMC\_ImageAcquire ( *HANDLE* Camera\_Handle, *PVOID\** ppData );

#### **Visual Basic 6.0**

*IMC\_ImageAcquire* (ByVal Camera\_Handle As Long, ppData As Long) As Integer

#### **C#.NET 2003**

*Mavis.IMC\_Image\_Acquire*( IntPtr Camera\_Handle, ref IntPtr ppData );

### **Description:**

This function sends the request to camera and receives the frame package when the acquisition completes. The *IMC\_ImageAcquisition\_Start* () should be called before calling this function.

### **Parameters:**

*Camera\_Handle*      The handle for MAVIS camera, use the handle gotten from the '**pHandle**' parameter of *IMC\_Camera\_Init*().

*ppData*              The pointer to the Address that contains the acquisition data.

### **Return:**

<i>ERROR_SUCCESSFUL</i>	Successfully
<i>ERROR_CAMERA_CREATE</i>	The Camera_Handle is NULL.
<i>ERROR_DEVICE_UNINIT</i>	The specific camera has not been initialized.
<i>ERROR_INVALID_CAMERA</i>	The handle is invalid.
<i>ERROR_1394FUNC_INCORRECT</i>	The error caused by port incorrect operation.
<i>ERROR_IMAGE_ACQUIRE</i>	Failure in frame acquisition

## *IMC\_ImageAcquisition\_Stop*

### **Syntax:**

#### **Visual C++ 6.0 / Boland C++ Builder 6.0:**

*short IMC\_ImageAcquisition\_Stop ( HANDLE Camera\_Handle);*

#### **Visual Basic 6.0**

*IMC\_ImageAcquisition\_Stop (ByVal Camera\_Handle As Long) As Integer*

#### **C#.NET 2003**

*Mavis.IMC\_ImageAcquisition\_Stop( IntPtr Camera\_Handle );*

### **Description:**

This function stops the Image Acquisition that started with `IMC_ImageAcquisition_Start()`. Be aware that the buffer that contains the acquisition data will be destroyed after calling this function.

### **Parameters:**

*Camera\_Handle*      The handle for MAVIS camera, use the handle gotten from the '**pHandle**' parameter of `IMC_Camera_Init()`.

### **Return:**

<i>ERROR_SUCCESSFUL</i>	Successfully
<i>ERROR_CAMERA_CREATE</i>	The Camera_Handle is NULL.
<i>ERROR_DEVICE_UNINIT</i>	The specific camera has not been initialized.
<i>ERROR_INVALID_CAMERA</i>	The handle is invalid.
<i>ERROR_1394FUNC_INCORRECT</i>	The error caused by port incorrect operation.
<i>ERROR_ACQUIMAGE_STOP</i>	Fail to stop the image acquisition.

## *IMC\_AcquisitionFrame\_Copy*

### **Syntax:**

#### **Visual C++ 6.0 / Boland C++ Builder 6.0:**

*short IMC\_AcquisitionFrame\_Copy ( HANDLE Camera\_Handle, PVOID pData );*

#### **Visual Basic 6.0**

*IMC\_AcquisitionFrame\_Copy (ByVal Camera\_Handle As Long, ByRef pData As Any) As Integer*

#### **C#.NET 2003**

*Mavis.IMC\_AcquisitionFrame\_Copy( IntPtr Camera\_Handle, IntPtr pData);*

### **Description:**

This function copies the acquisition frame into the buffer. *IMC\_Image\_Acquire ()* should be called before calling this function. This function is helpful to store the acquisition frame.

### **Parameters:**

*Camera\_Handle*      The handle for MAVIS camera, use the handle gotten from the '**pHandle**' parameter of *IMC\_Camera\_Init()*.

*pData*                The pointer to the buffer that acquisition frame will be copied into.

### **Return:**

<i>ERROR_SUCCESSFUL</i>	Successfully
<i>ERROR_CAMERA_CREATE</i>	The Camera_Handle is NULL.
<i>ERROR_DEVICE_UNINIT</i>	The specific camera has not been initialized.
<i>ERROR_INVALID_CAMERA</i>	The handle is invalid.
<i>ERROR_NOFRAME_AVAILABLE</i>	No Acquisition frame is available.

## *IMC\_AcquisitionFrame\_Save*

### **Syntax:**

#### **Visual C++ 6.0 / Boland C++ Builder 6.0:**

```
short IMC_AcquisitionFrame_Save ( HANDLE Camera_Handle, LPCTSTR  
strFileName );
```

#### **Visual Basic 6.0**

```
IMC_AcquisitionFrame_Save (ByVal Camera_Handle As Long, ByVal strFileName As  
String) As Integer
```

#### **C#.NET 2003**

```
Mavis.IMC_AcquisitionFrame_Save( IntPtr Camera_Handle, string  
strFileName);
```

### **Description:**

This function starts the Image Acquisition, and then saves the acquired image to a file. Currently, only BMP format is support. The camera needs be initialized with *IMC\_Camera\_Init()*.

### **Parameters:**

*Camera\_Handle* The handle for MAVIS camera, use the handle gotten from the '**pHandle**' parameter of *IMC\_Camera\_Init()*.

*strFileName* The string saves the full path-name of target image.

### **Return:**

<i>ERROR_SUCCESSFUL</i>	Successfully
<i>ERROR_INVALID_FILENAME</i>	The <i>strFileName</i> is NULL.
<i>ERROR_CAMERA_CREATE</i>	The <i>Camera_Handle</i> is NULL.
<i>ERROR_DEVICE_UNINIT</i>	The specific camera has not been initialized.
<i>ERROR_INVALID_CAMERA</i>	The handle is invalid.
<i>ERROR_1394FUNC_INCORRECT</i>	The error caused by port incorrect operation.
<i>ERROR_ACQUIMAGE_START</i>	Fail to start the image acquisition.
<i>ERROR_IMAGE_ACQUIRE</i>	Failure in frame acquisition
<i>ERROR_ACQUIMAGE_STOP</i>	Fail to stop the image acquisition.
<i>ERROR_BITMAPFILE_CREATE</i>	Fail to create the bitmap file.
<i>ERROR_BITMAPFILE_WRITE</i>	Fail to write the data into bitmap file.

## *IMC\_Live\_Acquire*

### **Syntax:**

#### **Visual C++ 6.0 / Boland C++ Builder 6.0:**

```
short IMC_Live_Acquire ( HANDLE Camera_Handle, void (__stdcall  
*callbackAddr)(void* pFrame) );
```

#### **Visual Basic 6.0**

```
IMC_Live_Acquire (ByVal Camera_Handle As Long, ByVal callbackAddr As Long) As  
Integer
```

#### **C#.NET 2003**

```
Mavis.IMC_Live_Acquire( IntPtr Camera_Handle, Callback cbf );
```

### **Description:**

This function starts one thread to call IMC\_ImageAcquire() continuously. If the callbackAddr is valid, the function will be called after each IMC\_ImageAcquire().

This function helps to simplify the programming for continuous Image-Acquisition.

The IMC\_ImageAcquisition\_Start () should be called before calling this function.

It is strongly recommended to stop the continuous Image Acquisition with IMC\_LiveAcquisition\_Stop() function. Specially, in Visual Basic exiting the VB program without calling IMC\_LiveAcquisition\_Stop() will terminate Visual Basic.

### **Parameters:**

*Camera\_Handle* The handle for MAVIS camera, use the handle gotten from the '**pHandle**' parameter of IMC\_Camera\_Init().

*callbackAddr* The Address of CallBack Function..

In Visual C++, the CallBack function must be declared as \_\_stdcall FunctionName (void\* pFrame).

In Visual Basic, one separate module contains the Callback Function.



**Return:**

<i>ERROR_SUCCESSFUL</i>	Successfully
<i>ERROR_CAMERA_CREATE</i>	The Camera_Handle is NULL.
<i>ERROR_DEVICE_UNINIT</i>	The specific camera has not been initialized.
<i>ERROR_INVALID_CAMERA</i>	The handle is invalid.
<i>ERROR_ACQUISITION_BUSY</i>	The camera is acquiring image
<i>ERROR_EVENT_CREATE</i>	Fail to create the associated event
<i>ERROR_THREAD_CREATE</i>	Fail to create the thread

## *IMC\_LiveAcquisition\_Stop*

### **Syntax:**

#### **Visual C++ 6.0 / Boland C++ Builder 6.0:**

*short IMC\_LiveAcquisition\_Stop ( HANDLE Camera\_Handle );*

#### **Visual Basic 6.0**

*IMC\_LiveAcquisition\_Stop (ByVal Camera\_Handle As Long) As Integer*

#### **C#.NET 2003**

*Mavis.IMC\_LiveAcquisition\_Stop( IntPtr Camera\_Handle );*

### **Description:**

This function ends the thread created by *IMC\_Live\_Acquire()* and then stops the Image Acquisition.

### **Parameters:**

*Camera\_Handle*     The handle for the MAVIS camera, use the handle gotten from the '***pHandle***' parameter of *IMC\_Camera\_Init()*.

### **Return:**

<i>ERROR_SUCCESSFUL</i>	Successfully
<i>ERROR_CAMERA_CREATE</i>	The Camera_Handle is NULL.
<i>ERROR_DEVICE_UNINIT</i>	The specific camera has not been initialized.
<i>ERROR_INVALID_CAMERA</i>	The handle is invalid.
<i>ERROR_ACQUIMAGE_STOP</i>	Fail to stop the image acquisition.

## 6.5 Camera Configuration

### *IMC\_FrameRate\_Set*

#### **Syntax:**

#### **Visual C++ 6.0 / Boland C++ Builder 6.0:**

```
short IMC_FrameRate_Set ( HANDLE Camera_Handle, ULONG FrameRate, BOOL  
bMirror = FALSE);
```

#### **Visual Basic 6.0**

```
IMC_FrameRate_Set (ByVal Camera_Handle As Long, ByVal FrameRate As Long,  
Optional ByVal bMirror As Boolean) As Integer
```

#### **C#.NET 2003**

```
Mavis.IMC_FrameRate_Set( IntPtr Camera_Handle, ulong FrameRate, bool  
bMirror );
```

#### **Description:**

This function sets the Frame Rate for MAVIS cameras. The camera needs to be initialized with *IMC\_Camera\_Init()*.

#### **Parameters:**

<i>Camera_Handle</i>	The handle for MAVIS camera, use the handle gotten from the ' <b>pHandle</b> ' parameter of <i>IMC_Camera_Init()</i> .
<i>FrameRate</i>	The Frame Rate setting for the MAVIS camera. The valid values are <i>FRAME_RATE_30</i> , <i>FRAME_RATE_60</i> , <i>FRAME_RATE_100</i>
<i>bMirror</i>	Enable/disable the Mirror mode. This flag is active for <i>FRAME_RATE_100</i> Frame Rate.

**Return:**

<i>ERROR_SUCCESSFUL</i>	Successfully
<i>ERROR_INVALID_FRAMERATE</i>	The invalid FrameRate
<i>ERROR_CAMERA_CREATE</i>	The Camera_Handle is NULL.
<i>ERROR_DEVICE_UNINIT</i>	The specific camera has not been initialized.
<i>ERROR_INVALID_CAMERA</i>	The handle is invalid.
<i>ERROR_1394FUNC_INCORRECT</i>	The error caused by port incorrect operation.
<i>ERROR_VIDEOFORMAT_SET</i>	Fail to set the Video Format
<i>ERROR_VIDEOMODE_SET</i>	Fail to set the Video Mode
<i>ERROR_FRAMERATE_SET</i>	Fail to set the Frame Rate

**The below errors only for FRAME\_RATE\_100:**

<i>ERROR_SIZE_INQUIRE</i>	Fail to inquire the maximum size
<i>ERROR_SIZE_STATUS</i>	Fail to get the current size-settings
<i>ERROR_SIZE_AOISSET</i>	Fail to set the size
<i>ERROR_POSITION_AOISSET</i>	Fail to set the Left-Top position
<i>ERROR_CORLOR_AOISSET</i>	Fail to set the color mode
<i>ERROR_BYTEPERPACKAGE_AOI_SET</i>	Fail to set the bytes per package

## *IMC\_Shutter\_Get*

### **Syntax:**

#### **Visual C++ 6.0 / Boland C++ Builder 6.0:**

*short IMC\_Shutter\_Get ( HANDLE Camera\_Handle, int\* pShutterValue);*

#### **Visual Basic 6.0**

*IMC\_Shutter\_Get (ByVal Camera\_Handle As Long, ByRef pShutterValue As Long) As Integer*

#### **C#.NET 2003**

*Mavis.IMC\_Shutter\_Get( IntPtr Camera\_Handle, IntPtr pShutterValue );*

### **Description:**

This function gets the current setting of Shutter Time. The camera needs be initialized with IMC\_Camera\_Init().

### **Parameters:**

*Camera\_Handle*      The handle for MAVIS camera, use the handle gotten from the '**pHandle**' parameter of IMC\_Camera\_Init().

*pShutterValue*      The pointer to integer that contains the Shutter-Time value (Timing unit in microsecond)

### **Return:**

<i>ERROR_SUCCESSFUL</i>	Successfully
<i>ERROR_CAMERA_CREATE</i>	The Camera_Handle is NULL.
<i>ERROR_DEVICE_UNINIT</i>	The specific camera has not been initialized.
<i>ERROR_INVALID_CAMERA</i>	The handle is invalid.

## *IMC\_Shutter\_Set*

### **Syntax:**

#### **Visual C++ 6.0 / Boland C++ Builder 6.0:**

*short IMC\_Shutter\_Set ( HANDLE Camera\_Handle, int ShutterValue);*

#### **Visual Basic 6.0**

*IMC\_Shutter\_Set (ByVal Camera\_Handle As Long, ByVal ShutterValue As Long) As Integer*

#### **C#.NET 2003**

*Mavis.IMC\_Shutter\_Set( IntPtr Camera\_Handle, int ShutterValue );*

### **Description:**

This function updates the setting of Shutter Time. The camera needs be initialized with IMC\_Camera\_Init().

### **Parameters:**

*Camera\_Handle*     The handle for MAVIS camera, use the handle gotten from the '**pHandle**' parameter of IMC\_Camera\_Init().

*ShutterValue*     The Shutter-Time value with valid range from 20 to 81900. (Timing unit in microsecond)

### **Return:**

<i>ERROR_SUCCESSFUL</i>	Successfully
<i>ERROR_CAMERA_CREATE</i>	The Camera_Handle is NULL.
<i>ERROR_DEVICE_UNINIT</i>	The specific camera has not been initialized.
<i>ERROR_INVALID_CAMERA</i>	The handle is invalid.
<i>ERROR_INAVLID_VALUE</i>	The invalid Shutter-Time value

## *IMC\_Gain\_Get*

### **Syntax:**

#### **Visual C++ 6.0 / Boland C++ Builder 6.0:**

*short IMC\_Gain\_Get ( HANDLE Camera\_Handle, int\* pGainValue);*

#### **Visual Basic 6.0**

*IMC\_Gain\_Get (ByVal Camera\_Handle As Long, ByRef pGainValue As Long) As Integer*

#### **C#.NET 2003**

*Mavis.IMC\_Gain\_Get( IntPtr Camera\_Handle, IntPtr pGainValue );*

### **Description:**

This function gets the current setting of Gain. The camera needs be initialized with IMC\_Camera\_Init().

### **Parameters:**

*Camera\_Handle*      The handle for MAVIS camera, use the handle gotten from the '**pHandle**' parameter of IMC\_Camera\_Init().

*pGainValue*        The pointer to integer that contains the Gain value

### **Return:**

<i>ERROR_SUCCESSFUL</i>	Successfully
<i>ERROR_CAMERA_CREATE</i>	The Camera_Handle is NULL.
<i>ERROR_DEVICE_UNINIT</i>	The specific camera has not been initialized.
<i>ERROR_INVALID_CAMERA</i>	The handle is invalid.

## *IMC\_Gain\_Set*

### **Syntax:**

#### **Visual C++ 6.0 / Boland C++ Builder 6.0:**

*short IMC\_Gain\_Set ( HANDLE Camera\_Handle, int GainValue);*

#### **Visual Basic 6.0**

*IMC\_Gain\_Set (ByVal Camera\_Handle As Long, ByVal GainValue As Long) As Integer*

#### **C#.NET 2003**

*Mavis.IMC\_Gain\_Set( IntPtr Camera\_Handle, int GainValue );*

### **Description:**

This function updates the setting of Gain. The camera needs be initialized with IMC\_Camera\_Init().

### **Parameters:**

*Camera\_Handle*      The handle for MAVIS camera, use the handle gotten from the '**pHandle**' parameter of IMC\_Camera\_Init().

*GainValue*          The Gain value with valid range from 0 to 255.

### **Return:**

<i>ERROR_SUCCESSFUL</i>	Successfully
<i>ERROR_CAMERA_CREATE</i>	The Camera_Handle is NULL.
<i>ERROR_DEVICE_UNINIT</i>	The specific camera has not been initialized.
<i>ERROR_INVALID_CAMERA</i>	The handle is invalid.
<i>ERROR_INAVLID_VALUE</i>	The invalid Gain value



## *IMC\_Brightness\_Get*

### **Syntax:**

#### **Visual C++ 6.0 / Boland C++ Builder 6.0:**

*short IMC\_Brightness\_Get ( HANDLE Camera\_Handle, int\* pBrightnessValue);*

#### **Visual Basic 6.0**

*IMC\_Brightness\_Get (ByVal Camera\_Handle As Long, ByRef pBrightnessValue As Long) As Integer*

#### **C#.NET 2003**

*Mavis.IMC\_Brightness\_Get( IntPtr Camera\_Handle, IntPtr pBrightnessValue );*

### **Description:**

This function gets the current setting of Brightness. The camera needs be initialized with IMC\_Camera\_Init().

### **Parameters:**

*Camera\_Handle*            The handle for MAVIS camera, use the handle gotten from the '**pHandle**' parameter of IMC\_Camera\_Init().

*pBrightnessValue*        The pointer to integer that contains the Brightness value

### **Return:**

<i>ERROR_SUCCESSFUL</i>	Successfully
<i>ERROR_CAMERA_CREATE</i>	The Camera_Handle is NULL.
<i>ERROR_DEVICE_UNINIT</i>	The specific camera has not been initialized.
<i>ERROR_INVALID_CAMERA</i>	The handle is invalid.

## *IMC\_Brightness\_Set*

### **Syntax:**

#### **Visual C++ 6.0 / Boland C++ Builder 6.0:**

*short IMC\_Brightness\_Set ( HANDLE Camera\_Handle, int BrightnessValue);*

#### **Visual Basic 6.0**

*IMC\_Brightness\_Set (ByVal Camera\_Handle As Long, ByVal BrightnessValue As Long)  
As Integer*

#### **C#.NET 2003**

*Mavis.IMC\_Brightness\_Set( IntPtr Camera\_Handle, int BrightnessValue );*

### **Description:**

This function updates the Brightness Configuration. The camera needs be initialized with IMC\_Camera\_Init().

### **Parameters:**

*Camera\_Handle*      The handle for MAVIS camera, use the handle gotten from the '**pHandle**' parameter of IMC\_Camera\_Init().

*BrightnessValue*      The Brightness value with valid range from 0 to 1023.

### **Return:**

<i>ERROR_SUCCESSFUL</i>	Successfully
<i>ERROR_CAMERA_CREATE</i>	The Camera_Handle is NULL.
<i>ERROR_DEVICE_UNINIT</i>	The specific camera has not been initialized.
<i>ERROR_INVALID_CAMERA</i>	The handle is invalid.
<i>ERROR_INAVLID_VALUE</i>	The invalid Brightness value

## 6.6 Digital Input/Output

### *IMC\_OutputPort\_Status*

#### **Syntax:**

#### **Visual C++ 6.0 / Boland C++ Builder 6.0:**

```
short IMC_OutputPort_Status ( HANDLE Camera_Handle, unsigned long*  
pOutputStatus);
```

#### **Visual Basic 6.0**

```
IMC_OutputPort_Status (ByVal Camera_Handle As Long, ByRef pOutputStatus As  
Long) As Integer
```

#### **C#.NET 2003**

```
Mavis.IMC_OutputPort_Status( IntPtr Camera_Handle, out ulong pOutputStatus );
```

#### **Description:**

This function gets the hardware sources for all Output Ports. The camera needs be initialized with IMC\_Camera\_Init().

#### **Parameters:**

<i>Camera_Handle</i>	The handle for MAVIS camera, use the handle gotten from the ' <b>pHandle</b> ' parameter of IMC_Camera_Init().
<i>pOutputStatus</i>	The pointer to Signal Source settings of all four Output Ports. The Signal Source configuration will be: INTEGRATE_ENABLED_SIGNAL (0x00) TRIGGER_READY_SIGNAL (0x01) USER_SET_SIGNAL (0x03) STROBE_SIGNAL (0x04)

Each byte of OutputStatus stands for independent configuration of every Output Port.

For instance, 0x03030100 means that:

OutputPort#0 is configured to INTEGRATE\_ENABLED\_SIGNAL

OutputPort#1 is configured to TRIGGER\_READY\_SIGNAL

OutputPort#2 and OutputPort#3 are configured to USER\_SET\_SIGNAL

**Return:**

<i>ERROR_SUCCESSFUL</i>	Successfully
<i>ERROR_CAMERA_CREATE</i>	The Camera_Handle is NULL.
<i>ERROR_DEVICE_UNINIT</i>	The specific camera has not been initialized.
<i>ERROR_INVALID_CAMERA</i>	The handle is invalid.

## *IMC\_OutputPort\_Configure*

### **Syntax:**

#### **Visual C++ 6.0 / Boland C++ Builder 6.0:**

```
short IMC_OutputPort_Configure ( HANDLE Camera_Handle, int Output_Port, int  
Source_Signal);
```

#### **Visual Basic 6.0**

```
IMC_OutputPort_Configure (ByVal Camera_Handle As Long, ByVal Output_Port As  
Long, ByVal Source_Signal As Long) As Integer
```

#### **C#.NET 2003**

```
Mavis.IMC_OutputPort_Configure( IntPtr Camera_Handle, int Output_Port, int  
Source_Signal );
```

### **Description:**

This function configures the hardware sources for specific Output Port. The camera needs be initialized with IMC\_Camera\_Init().

### **Parameters:**

<i>Camera_Handle</i>	The handle for MAVIS camera, use the handle gotten from the ' <b>pHandle</b> ' parameter of IMC_Camera_Init().
	Output_Port: The Output Port to be configured. The Ports can be: OUTPUT_PORT_0, OUTPUT_PORT_1, OUTPUT_PORT_2 and OUTPUT_PORT_3
<i>Signal_Source</i>	The hardware Signal Source for Output Port and the sources can be: INTEGRATE_ENABLED_SIGNAL (0x00), TRIGGER_READY_SIGNAL (0x01), USER_SET_SIGNAL (0x03) STROBE_SIGNAL (0x04)

**Return:**

<i>ERROR_SUCCESSFUL</i>	Successfully
<i>ERROR_INVALID_PORT</i>	The invalid output port.
<i>ERROR_INVALID_SOURCE_SIGNAL</i>	The invalid source signal.
<i>ERROR_CAMERA_CREATE</i>	The Camera_Handle is NULL.
<i>ERROR_DEVICE_UNINIT</i>	The specific camera has not been initialized.
<i>ERROR_INVALID_CAMERA</i>	The handle is invalid.
<i>ERROR_SOURCE_NOT_SUPPORT</i>	The source signal is not supported by that specific output port.

## *IMC\_OutputPort\_Write*

### **Syntax:**

#### **Visual C++ 6.0 / Boland C++ Builder 6.0:**

```
short IMC_OutputPort_Write ( HANDLE Camera_Handle, int Output_Port, bool  
bValue);
```

#### **Visual Basic 6.0**

```
IMC_OutputPort_Write (ByVal Camera_Handle As Long, ByVal Output_Port As Long,  
ByVal bValue As Boolean) As Integer
```

#### **C#.NET 2003**

```
Mavis.IMC_OutputPort_Write( IntPtr Camera_Handle, int Output_Port, bool bValue );
```

### **Description:**

This function sets the state for specific Output Port. This function is workable only for the Output Ports that are configured to USER\_SET\_SIGNAL .The camera needs be initialized with IMC\_Camera\_Init().

### **Parameters:**

<i>Camera_Handle</i>	The handle for MAVIS camera, use the handle gotten from the ' <b>pHandle</b> ' parameter of IMC_Camera_Init().
<i>Output_Port</i>	The Output Port to be set. The Ports can be: OUTPUT_PORT_0, OUTPUT_PORT_1, OUTPUT_PORT_2 and OUTPUT_PORT_3
<i>bValue</i>	The state for specific Output Port.

### **Return:**

<i>ERROR_SUCCESSFUL</i>	Successfully
<i>ERROR_INVALID_PORT</i>	The invalid output port.
<i>ERROR_CAMERA_CREATE</i>	The Camera_Handle is NULL.
<i>ERROR_DEVICE_UNINIT</i>	The specific camera has not been initialized.
<i>ERROR_INVALID_CAMERA</i>	The handle is invalid.
<i>ERROR_NOT_USERSET_MODE</i>	The Output Port is not configured as USER_SET_SIGNAL.

## *IMC\_InputPort\_Read*

### **Syntax:**

#### **Visual C++ 6.0 / Boland C++ Builder 6.0:**

```
short IMC_InputPort_Read ( HANDLE Camera_Handle, int Input_Port, bool* pValue);
```

#### **Visual Basic 6.0**

```
IMC_InputPort_Read (ByVal Camera_Handle As Long, ByVal Input_Port As Long,  
ByRef pValue As Boolean) As Integer
```

#### **C#.NET 2003**

```
Mavis.IMC_InputPort_Read( IntPtr Camera_Handle, int Input_Port, out bool  
pValue );
```

### **Description:**

This function reads the state for specific Input Port. The camera needs be initialized with IMC\_Camera\_Init().

### **Parameters:**

<i>Camera_Handle</i>	The handle for MAVIS camera. Use the handle gotten from the ' <b>pHandle</b> ' parameter of IMC_Camera_Init().
<i>Input_Port</i>	The Input Port to be read. The Ports can be: INPUT_PORT_0 and INPUT_PORT_1
<i>pValue</i>	The pointer to the memory that contains state of the specific Input Port.

### **Return:**

<i>ERROR_SUCCESSFUL</i>	Successfully
<i>ERROR_INVALID_PORT</i>	The invalid input port.
<i>ERROR_CAMERA_CREATE</i>	The Camera_Handle is NULL.
<i>ERROR_DEVICE_UNINIT</i>	The specific camera has not been initialized.
<i>ERROR_INVALID_CAMERA</i>	The handle is invalid.



## *IMC\_InputPort\_ReadAll*

### **Syntax:**

#### **Visual C++ 6.0 / Boland C++ Builder 6.0:**

*short IMC\_InputPort\_ReadAll ( HANDLE Camera\_Handle, unsigned long\* pValue);*

#### **Visual Basic 6.0**

*IMC\_InputPort\_ReadAll (ByVal Camera\_Handle As Long, ByRef pValue As Long) As Integer*

#### **C#.NET 2003**

*Mavis.IMC\_InputPort\_ReadAll( IntPtr Camera\_Handle, out ulong pValue );*

### **Description:**

This function reads the state for both Input Ports. The camera needs be initialized with IMC\_Camera\_Init().

### **Parameters:**

<i>Camera_Handle</i>	The handle for MAVIS camera. Use the handle gotten from the ' <b>pHandle</b> ' parameter of IMC_Camera_Init().
<i>pValue</i>	The pointer to the memory that combines the states of all Input Ports. The Byte0 contains state of INPUT_PORT_0 and Byte1 contains state of INPUT_PORT_1.

### **Return:**

<i>ERROR_SUCCESSFUL</i>	Successfully
<i>ERROR_CAMERA_CREATE</i>	The Camera_Handle is NULL.
<i>ERROR_DEVICE_UNINIT</i>	The specific camera has not been initialized.
<i>ERROR_INVALID_CAMERA</i>	The handle is invalid.

## 6.7 External Trigger

### *IMC\_Trigger\_Enable*

#### **Syntax:**

#### **Visual C++ 6.0 / Boland C++ Builder 6.0:**

```
short IMC_Trigger_Enable( HANDLE Camera_Handle, int iTrigSource, int  
iExpMode);
```

#### **Visual Basic 6.0**

```
IMC_Trigger_Enable (ByVal Camera_Handle As Long, ByVal iTrigSource As Integer,  
ByVal iExpMode As Integer) As Integer
```

#### **C#.NET 2003**

```
Mavis.IMC_Trigger_Enable( IntPtr Camera_Handle, int iTrigSource, int iExpMode);
```

#### **Description:**

This function configures the External Trigger Source and enables External Trigger. The camera needs be initialized with IMC\_Camera\_Init().

#### **Parameters:**

<i>Camera_Handle</i>	The handle for MAVIS camera. Use the handle gotten from the ' <b>pHandle</b> ' parameter of IMC_Camera_Init().
<i>iTrig_Source</i>	The setting of External Trigger Source. The Sources of External Trigger can be one of following settings: EXT_TRIGGER_INPUT0 (0x00) EXT_TRIGGER_INOUT1 (0x01) EXT_TRIGGER_SOFTWARE (0x07) By default, the Trigger Source of iTrigSource is EXT_TRIGGER_INPUT0
<i>iExpMode</i>	The setting of Trigger Exposure Mode. The Exposure Mode can be one of bellowing Settings: EXT_TRIGGER_MODE0 (Programmable Mode) EXT_TRIGGER_MODE1 (Level Mode) By default, the Trigger Exposure Mode of iExpMode is EXT_TRIGGER_MODE1

**Return:**

<i>ERROR_SUCCESSFUL</i>	Successfully
<i>ERROR_CAMERA_CREATE</i>	The Camera_Handle is NULL.
<i>ERROR_DEVICE_UNINIT</i>	The specific camera has not been initialized.
<i>ERROR_INVALID_CAMERA</i>	The handle is invalid.

## *IMC\_Trigger\_Disable*

### **Syntax:**

#### **Visual C++ 6.0 / Boland C++ Builder 6.0:**

*short IMC\_Trigger\_Disable ( HANDLE Camera\_Handle);*

#### **Visual Basic 6.0**

*IMC\_Trigger\_Disable (ByVal Camera\_Handle As Long) As Integer*

#### **C#.NET 2003**

*Mavis.IMC\_Trigger\_Disable( IntPtr Camera\_Handle);*

### **Description:**

This function disables the External Trigger. The camera needs be initialized with IMC\_Camera\_Init().

### **Parameters:**

*Camera\_Handle*      The handle for MAVIS camera. Use the handle gotten from the '**pHandle**' parameter of IMC\_Camera\_Init().

### **Return:**

<i>ERROR_SUCCESSFUL</i>	Successfully
<i>ERROR_CAMERA_CREATE</i>	The Camera_Handle is NULL.
<i>ERROR_DEVICE_UNINIT</i>	The specific camera has not been initialized.
<i>ERROR_INVALID_CAMERA</i>	The handle is invalid.

## *IMC\_Trigger\_ReadConfiguration*

### **Syntax:**

#### **Visual C++ 6.0 / Boland C++ Builder 6.0:**

```
short IMC_Trigger_ReadConfiguration( HANDLE Camera_Handle, bool* pStatus,  
unsigned short* pTrigSource, unsigned short* pExpMode);
```

#### **Visual Basic 6.0**

```
IMC_Trigger_ReadConfiguration (ByVal Camera_Handle As Long, ByRef pStatus As  
Boolean, ByRef pTrigSource As Integer, ByRef pExpMode As Integer) As Integer
```

#### **C#.NET 2003**

```
Mavis. IMC_Trigger_ReadConfiguration( IntPtr Camera_Handle, out bool pStatus, out  
Int32 pTrigSource, out Int32 pExpMode);
```

### **Description:**

This function reads the current setting for External Trigger. The camera needs be initialized with IMC\_Camera\_Init().

### **Parameters:**

<i>Camera_Handle</i>	The handle for MAVIS camera. Use the handle gotten from the ' <b>pHandle</b> ' parameter of IMC_Camera_Init().
<i>pStatus</i>	Enable or Disable camera external trigger function. The value can be TRUE for trigger enable or FLASE for trigger disable and default value of pStatus is FLASE.
<i>pTrigSource</i>	The pointer to the integer that indicates the settings of External Trigger Source. The Sources of External Trigger may be one of following values: EXT_TRIGGER_INPUT0 (0x00) EXT_TRIGGER_INOUT1 (0x01) EXT_TRIGGER_SOFTWARE (0x07) By default, the Trigger Source of iTrigSource is EXT_TRIGGER_INPUT0
<i>pExpMode</i>	The setting of Trigger Exposure Mode. The Exposure Mode can be one of bellowing Settings: EXT_TRIGGER_MODE0 (Programmable Mode) EXT_TRIGGER_MODE1 (Level Mode) By default, the Trigger Exposure Mode of iExpMode is EXT_TRIGGER_MODE1

**Return:**

*ERROR\_SUCCESSFUL*

Successfully

*ERROR\_CAMERA\_CREATE*

The Camera\_Handle is NULL.

*ERROR\_DEVICE\_UNINIT*

The specific camera has not been initialized.

*ERROR\_INVALID\_CAMERA*

The handle is invalid.

## 6.8 Strobe Control

### *IMC\_StrobeControl\_SetConfiguration*

#### Syntax:

#### Visual C++ 6.0 / Boland C++ Builder 6.0:

*short* IMC\_StrobeControl\_SetConfiguration (*HANDLE* Camera\_Handle, unsigned short *sStrobeIndex*, bool *bOnOff*, bool *bPolarity*, unsigned long *IDelay*, unsigned long *IDuration*);

#### Visual Basic 6.0

*IMC\_StrobeControl\_SetConfiguration* (ByVal Camera\_Handle As Long, ByVal *sStrobeIndex* As Integer, ByVal *bOnOff* As Boolean, ByVal *bPolarity* As Boolean, ByVal *IDelay* As Long, ByVal *IDuration* As Long) As Integer

#### C#.NET 2003

*Mavis.IMC\_StrobeControl\_SetConfiguration* (IntPtr Camera\_Handle, Int32 *sStrobeIndex*, bool *bOnOff*, bool *bPolarity*, Int32 *IDelay*, Int32 *IDuration*);

#### Description:

This function sets the state of specific Strobe Control. This function is workable only for the Output Ports that are configured to STROBE\_SIGNAL. The camera needs be initialized with IMC\_Camera\_Init().

#### Parameters:

<i>Camera_Handle</i>	The handle for MAVIS camera. Use the handle gotten from the ' <b>pHandle</b> ' parameter of IMC_Camera_Init().
<i>sStrobeIndex</i>	The register index of Strobe Control and allows value from 0 ~3.
<i>bOnOff</i>	Enable or Disable strobe function. The value can be TRUE for enable strobe or FALSE for disable strobe.
<i>bPolarity</i>	The signal pulse setting for active Strobe Control and pPolarity can be one of below settings. STROBE_CONTROL_LOWACTIVE STROBE_CONTROL_HIGHACTIVE By default, the polarity of Strobe Control is STROBE_CONTROL_HIGHACTIVE.

<i>IDelay</i>	The delay time of Strobe and the Delay Value range from 0 to 4095. By default, the delay time is setting on 0.
<i>IDuration</i>	The Duration Time of Strobe and the Strobe Duration range from 0 to 4095. By default, the duration is setting on 0.

**Return:**

<i>ERROR_SUCCESSFUL</i>	Successfully
<i>ERROR_CAMERA_CREATE</i>	The Camera_Handle is NULL.
<i>ERROR_INVALID_PORT</i>	The invalid output port.
<i>ERROR_INVALID_SOURCE_SIGNAL</i>	The invalid source signal.
<i>ERROR_DEVICE_UNINIT</i>	The specific camera has not been initialized.
<i>ERROR_INVALID_CAMERA</i>	The handle is invalid.
<i>ERROR_SOURCE_NOT_SUPPORT</i>	The source signal is not supported by that specific output port.



## *IMC\_StrobeControl\_ReadConfiguration*

### **Syntax:**

#### **Visual C++ 6.0 / Boland C++ Builder 6.0:**

*short IMC\_StrobeControl\_ReadConfiguration (HANDLE Camera\_Handle, unsigned short sStrobeIndex, bool\* pOnOff, bool\* pPolarity, unsigned long\* pDelay, unsigned long\* pDuration);*

#### **Visual Basic 6.0**

*IMC\_StrobeControl\_ReadConfiguration (ByVal Camera\_Handle As Long, ByVal sStrobeIndex As Integer, ByRef pOnOff As Boolean, ByRef pPolarity As Boolean, ByRef pDelay As Long, ByRef pDuration As Long) As Integer*

#### **C#.NET 2003**

*Mavis.IMC\_StrobeControl\_ReadConfiguration (IntPtr Camera\_Handle, Int32 sStrobeIndex, ref bool pOnOff, ref bool pPolarity, ref Int32 pDelay, ref Int32 pDuration);*

### **Description:**

This function reads the current setting of specific Strobe Control. This function is workable only for the Output Ports that are configured to STROBE\_SIGNAL. The camera needs be initialized with IMC\_Camera\_Init().

### **Parameters:**

<i>Camera_Handle</i>	The handle for MAVIS camera. Use the handle gotten from the ' <b>pHandle</b> ' parameter of IMC_Camera_Init().
<i>sStrobeIndex</i>	The register index of Strobe Control and allows value from 0 ~3.
<i>pOnOff</i>	Enable or Disable strobe function. The value can be TRUE for enable strobe or FALSE for disable strobe.
<i>pPolarity</i>	The signal pulse setting for active Strobe Control and pPolarity can be one of below settings. STROBE_CONTROL_LOWACTIVE STROBE_CONTROL_HIGHACTIVE By default, the polarity of Strobe Control is STROBE_CONTROL_HIGHACTIVE.
<i>pDelay</i>	The delay time of Strobe and the Delay Value range from 0 to 4095. By default, the delay time is setting on 0.
<i>pDuration</i>	The Duration Time of Strobe and the Strobe Duration range from 0 to 4095. By default, the duration is setting on 0.

**Return:**

*ERROR\_SUCCESSFUL*

Successfully

*ERROR\_CAMERA\_CREATE*

The Camera\_Handle is NULL.

*ERROR\_DEVICE\_UNINIT*

The specific camera has not been initialized.

*ERROR\_INVALID\_CAMERA*

The handle is invalid.

*ERROR\_SOURCE\_NOT\_SUPPORT*

The source signal is not supported by that specific output port.

## *IMC\_StrobeTimeBase\_SetDurationTime*

### **Syntax:**

#### **Visual C++ 6.0 / Boland C++ Builder 6.0:**

*short IMC\_StrobeTimeBase\_SetDurationTime (HANDLE Camera\_Handle, unsigned long Value);*

#### **Visual Basic 6.0**

*IMC\_StrobeTimeBase\_SetDurationTime (ByVal Camera\_Handle As Long, ByVal Value As Long) As Integer*

#### **C#.NET 2003**

*Mavis. IMC\_StrobeTimeBase\_SetDurationTime(IntPtr Camera\_Handle, Int32 Value);*

### **Description:**

This function set the Duration Time of Strobe. This function is workable only for the Output Ports that are configured to STROBE\_SIGNAL. The camera needs be initialized with IMC\_Camera\_Init().

### **Parameters:**

*Camera\_Handle*      The handle for MAVIS camera. Use the handle gotten from the '**pHandle**' parameter of IMC\_Camera\_Init().

*Value*              The Duration Time of Strobe Control and allows value from 1 ~85. By default, the Value is setting on 1.

### **Return:**

<i>ERROR_SUCCESSFUL</i>	Successfully
<i>ERROR_CAMERA_CREATE</i>	The Camera_Handle is NULL.
<i>ERROR_DEVICE_UNINIT</i>	The specific camera has not been initialized.
<i>ERROR_INVALID_CAMERA</i>	The handle is invalid.
<i>ERROR_SOURCE_NOT_SUPPORT</i>	The source signal is not supported by that specific output port.

## *IMC\_StrobeTimeBase\_ReadConfiguration*

### **Syntax:**

#### **Visual C++ 6.0 / Boland C++ Builder 6.0:**

*short IMC\_StrobeTimeBase\_ReadConfiguration (HANDLE Camera\_Handle, unsigned long\* pDurationTime, unsigned long\* pDelayTime);*

#### **Visual Basic 6.0**

*IMC\_StrobeTimeBase\_ReadConfiguration (ByVal Camera\_Handle As Long, ByRef pDurationTime As Integer, ByRef pDelayTime As Integer) As Integer*

#### **C#.NET 2003**

*Mavis.IMC\_StrobeTimeBase\_ReadConfiguration (IntPtr Camera\_Handle, out Int32 pDurationTime, out Int32 pDelayTime);*

### **Description:**

This function reads the current setting of Strobe Time Base. The camera needs be initialized with *IMC\_Camera\_Init()*.

### **Parameters:**

<i>Camera_Handle</i>	The handle for MAVIS camera. Use the handle gotten from the ' <b>pHandle</b> ' parameter of <i>IMC_Camera_Init()</i> .
<i>pDurationTime</i>	The Duration Time of Strobe Time Base and allows value from 1 ~85. By default, the Value is setting on 1.
<i>pDelayTime</i>	The Delay Time of Strobe Time Base and allows value from 1 ~85. By default, the Value is setting on 1.

### **Return:**

<i>ERROR_SUCCESSFUL</i>	Successfully
<i>ERROR_CAMERA_CREATE</i>	The Camera_Handle is NULL.
<i>ERROR_DEVICE_UNINIT</i>	The specific camera has not been initialized.
<i>ERROR_INVALID_CAMERA</i>	The handle is invalid.
<i>ERROR_SOURCE_NOT_SUPPORT</i>	The source signal is not supported by that specific output port.

## 6.9 Lookup Table

### *IMC\_LUT\_Read*

#### **Syntax:**

#### **Visual C++ 6.0 / Boland C++ Builder 6.0:**

*short IMC\_LUT\_Read ( HANDLE Camera\_Handle, unsigned long\* pStartAddr );*

#### **Visual Basic 6.0**

*IMC\_LUT\_Read(ByVal Camera\_Handle As Long, ByRef pStartAddr As Long) As Integer*

#### **C#.NET 2003**

*Mavis. IMC\_LUT\_Read( IntPtr Camera\_Handle, Int32[] pStartAddr );*

#### **Description:**

This function reads the content of camera Lookup Table. There have list 1024 values in Lookup Table for present the depth of camera output pixel values. The camera needs be initialized with IMC\_Camera\_Init().

#### **Parameters:**

*Camera\_Handle*      The handle for MAVIS camera. Use the handle gotten from the '**pHandle**' parameter of IMC\_Camera\_Init().

*pStartAddr*         The memory start address point of Lookup Table.

#### **Return:**

<i>ERROR_SUCCESSFUL</i>	Successfully
<i>ERROR_CAMERA_CREATE</i>	The Camera_Handle is NULL.
<i>ERROR_DEVICE_UNINIT</i>	The specific camera has not been initialized.
<i>ERROR_INVALID_CAMERA</i>	The handle is invalid.

## *IMC\_LUT\_SetStatus*

### **Syntax:**

#### **Visual C++ 6.0 / Boland C++ Builder 6.0:**

*short IMC\_LUT\_SetStatus (HANDLE Camera\_Handle, bool status);*

#### **Visual Basic 6.0**

*IMC\_LUT\_SetStatus(ByVal Camera\_Handle As Long, ByVal status As Boolean) As Integer*

#### **C#.NET 2003**

*Mavis. IMC\_LUT\_SetStatus(IntPtr Camera\_Handle, bool status);*

### **Description:**

This function is enable/disable to modify the camera Lookup Table. The camera needs be initialized with IMC\_Camera\_Init().

### **Parameters:**

<i>Camera_Handle</i>	The handle for MAVIS camera. Use the handle gotten from the ' <b>pHandle</b> ' parameter of IMC_Camera_Init().
<i>status</i>	To allow to modify the Lookup Table content when status is setting on TRUE. By default, the status is setting on FALSE.

### **Return:**

<i>ERROR_SUCCESSFUL</i>	Successfully
<i>ERROR_CAMERA_CREATE</i>	The Camera_Handle is NULL.
<i>ERROR_DEVICE_UNINIT</i>	The specific camera has not been initialized.
<i>ERROR_INVALID_CAMERA</i>	The handle is invalid.

## *IMC\_LUT\_ReadStatus*

### **Syntax:**

#### **Visual C++ 6.0 / Boland C++ Builder 6.0:**

*IMC\_LUT\_ReadStatus (HANDLE Camera\_Handle, bool\* pStatus);*

#### **Visual Basic 6.0**

*IMC\_LUT\_ReadStatus (ByVal Camera\_Handle As Long, ByRef pStatus As Boolean) As Integer*

#### **C#.NET 2003**

*Mavis. IMC\_LUT\_ReadStatus (IntPtr Camera\_Handle, bool pStatus);*

### **Description:**

This function read the current status of camera Lookup Table. The camera needs be initialized with IMC\_Camera\_Init().

### **Parameters:**

<i>Camera_Handle</i>	The handle for MAVIS camera. Use the handle gotten from the ' <b>pHandle</b> ' parameter of IMC_Camera_Init().
<i>pStatus</i>	To read the Lookup Table current status. When enable Lookup Table then status will be TRUE. By default, the status is setting on FALSE.

### **Return:**

<i>ERROR_SUCCESSFUL</i>	Successfully
<i>ERROR_CAMERA_CREATE</i>	The Camera_Handle is NULL.
<i>ERROR_DEVICE_UNINIT</i>	The specific camera has not been initialized.
<i>ERROR_INVALID_CAMERA</i>	The handle is invalid.

## *IMC\_LUT\_Write*

### **Syntax:**

#### **Visual C++ 6.0 / Boland C++ Builder 6.0:**

*short IMC\_LUT\_Write( HANDLE Camera\_Handle, unsigned long\* pStartAddr);*

#### **Visual Basic 6.0**

*IMC\_LUT\_Write (ByVal Camera\_Handle As Long, ByRef pStartAddr As Long) As Integer*

#### **C#.NET 2003**

*Mavis. IMC\_LUT\_Write( IntPtr Camera\_Handle, Int32[] pStartAddr );*

### **Description:**

This function can modify the content of camera Lookup Table. The *IMC\_LUT\_SetStatus ()* should be called before calling this function. The camera needs be initialized with *IMC\_Camera\_Init()*.

### **Parameters:**

*Camera\_Handle*      The handle for MAVIS camera. Use the handle gotten from the '**pHandle**' parameter of *IMC\_Camera\_Init()*.

*pStartAddr*         The memory start address point of Lookup Table.

### **Return:**

<i>ERROR_SUCCESSFUL</i>	Successfully
<i>ERROR_CAMERA_CREATE</i>	The Camera_Handle is NULL.
<i>ERROR_DEVICE_UNINIT</i>	The specific camera has not been initialized.
<i>ERROR_INVALID_CAMERA</i>	The handle is invalid.



## 6.10 AOI (Area of Interest)

### *IMC\_AOI\_Configure*

#### **Syntax:**

#### **Visual C++ 6.0 / Boland C++ Builder 6.0:**

```
short IMC_AOI_Configure ( HANDLE Camera_Handle, PIMC_AOI_RECT_AREA  
pRectA);
```

#### **Visual Basic 6.0**

```
IMC_AOI_Configure (ByVal Camera_Handle As Long, ByRef pRectA As  
IMC_AOI_RECT_AREA) As Integer
```

#### **C#.NET 2003**

```
Mavis.IMC_AOI_Configure( IntPtr Camera_Handle, ref IMC_AOI_RECT_AREA  
p_ExtTrigSrc);
```

#### **Description:**

This function configures Area of Interest (AOI) region for Format7/Mode0. The camera needs to be initialized with IMC\_Camera\_Init().

#### **Parameters:**

<i>Camera_Handle</i>	The handle for MAVIS camera. Use the handle gotten from the ' <b>pHandle</b> ' parameter of IMC_Camera_Init().
<i>pRectA</i>	The pointer to IMC_AOI_RECT_AREA structure that contains the rectangle defined for AOI. There are some limitations for member variable of pRectA: <ol style="list-style-type: none"><li>1. For the DWORD-Alignment issue of BITMAP, the width of the AOI had must be a multiple of four.</li><li>2. The sum of start_x and width cannot be larger than 640</li><li>3. The sum of start_y and height cannot be larger than 480.</li></ol>

**Return:**

<i>ERROR_SUCCESSFUL</i>	Successfully
<i>ERROR_CAMERA_CREATE</i>	The Camera_Handle is NULL.
<i>ERROR_DEVICE_UNINIT</i>	The specific camera has not been initialized.
<i>ERROR_INVALID_CAMERA</i>	The handle is invalid.
<i>ERROR_1394FUNC_INCORRECT</i>	The error caused by port incorrect operation.
<i>ERROR_VIDEOFORMAT_SET</i>	Fail to set the Video Format
<i>ERROR_VIDEOMODE_SET</i>	Fail to set the Video Mode
<i>ERROR_SIZE_INQUIRE</i>	Fail to inquire the maximum size
<i>ERROR_SIZE_STATUS</i>	Fail to get the current size-settings
<i>ERROR_SIZE_AOISSET</i>	Fail to set the size
<i>ERROR_POSITION_AOISSET</i>	Fail to set the Left-Top position
<i>ERROR_CORLOR_AOISSET</i>	Fail to set the color mode
<i>ERROR_BYTEPERPACKAGE_AOI_SET</i>	Fail to set the bytes per package

## 6.11 Advanced Features

### *IMC\_TestImage\_Enable*

#### **Syntax:**

#### **Visual C++ 6.0 / Boland C++ Builder 6.0:**

*short IMC\_TestImage\_Enable ( HANDLE Camera\_Handle );*

#### **Visual Basic 6.0**

*IMC\_TestImage\_Enable (ByVal Camera\_Handle As Long) As Integer*

#### **C#.NET 2003**

*Mavis.IMC\_TestImage\_Enable( IntPtr Camera\_Handle );*

#### **Description:**

This function enables the Test Image Advanced Feature. This feature is helpful for self-testing. The camera needs be initialized with IMC\_Camera\_Init().

#### **Parameters:**

*Camera\_Handle*      The handle for MAVIS camera. Use the handle gotten from the '**pHandle**' parameter of IMC\_Camera\_Init().

#### **Return:**

<i>ERROR_SUCCESSFUL</i>	Successfully
<i>ERROR_CAMERA_CREATE</i>	The Camera_Handle is NULL.
<i>ERROR_DEVICE_UNINIT</i>	The specific camera has not been initialized.
<i>ERROR_INVALID_CAMERA</i>	The handle is invalid.
<i>ERROR_TESTIMAGE_SET</i>	Fail to enable the Test Image feature.

## *IMC\_TestImage\_Disable*

### **Syntax:**

#### **Visual C++ 6.0 / Boland C++ Builder 6.0:**

*short IMC\_TestImage\_Disable ( HANDLE Camera\_Handle);*

#### **Visual Basic 6.0**

*IMC\_TestImage\_Disable (ByVal Camera\_Handle As Long) As Integer*

#### **C#.NET 2003**

*Mavis.IMC\_TestImage\_Disable( IntPtr Camera\_Handle );*

### **Description:**

This function disables the Test Image Advanced Feature. This feature is helpful for self-testing. The camera needs be initialized with IMC\_Camera\_Init().

### **Parameters:**

*Camera\_Handle*      The handle for MAVIS camera. Use the handle gotten from the '**pHandle**' parameter of IMC\_Camera\_Init().

### **Return:**

<i>ERROR_SUCCESSFUL</i>	Successfully
<i>ERROR_CAMERA_CREATE</i>	The Camera_Handle is NULL.
<i>ERROR_DEVICE_UNINIT</i>	The specific camera has not been initialized.
<i>ERROR_INVALID_CAMERA</i>	The handle is invalid.
<i>ERROR_TESTIMAGE_SET</i>	Fail to disable the Test Image feature.

## 6.12 Sample Programs

After driver installation completed then you can find the sample program in \MAVIS\Samples\ path.

The sample program offers similar function modules as used in EZView and the source code for VC++, BCB, C#.NET and VB language programming reference.

### 6.12.1 Sample program for VC++/BCB/C#.NET

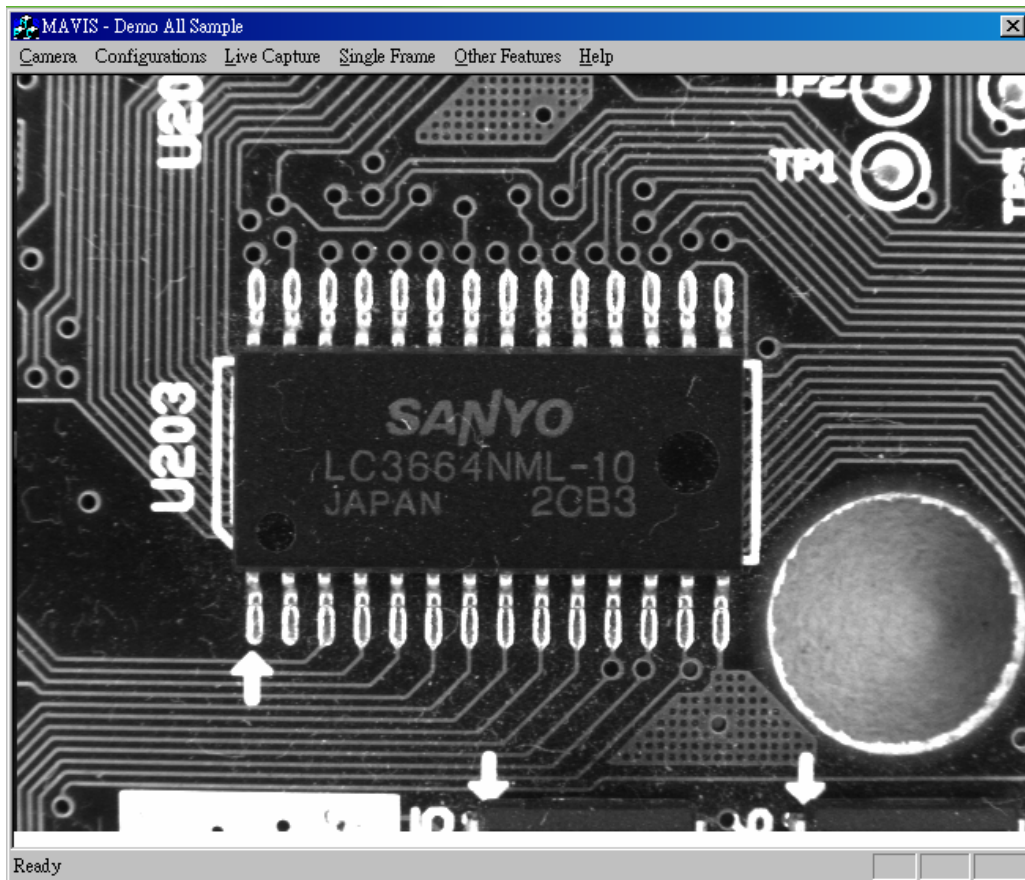

## 6.12.2 Sample program for VB

VB sample program are offer “IMCamera.bas” modules which has offer similar functions definition as VC lib. And use “PictureBox” OCX object for image display need.

An OCX control API version for MAVIS will be released in the next revision.

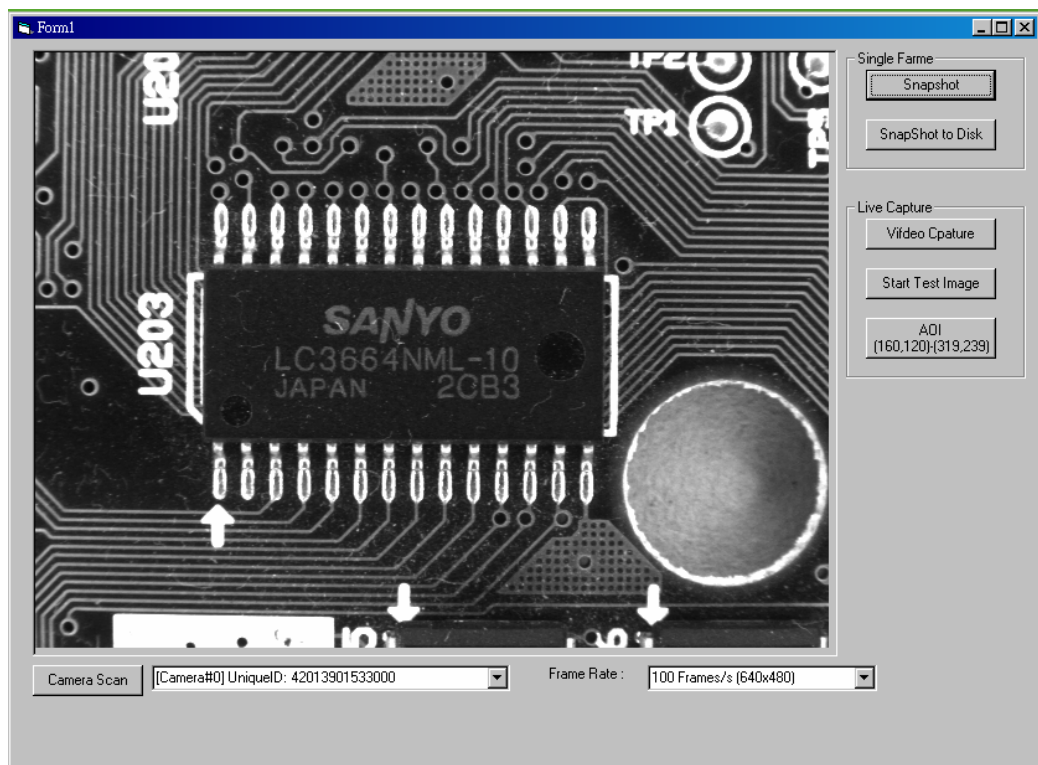
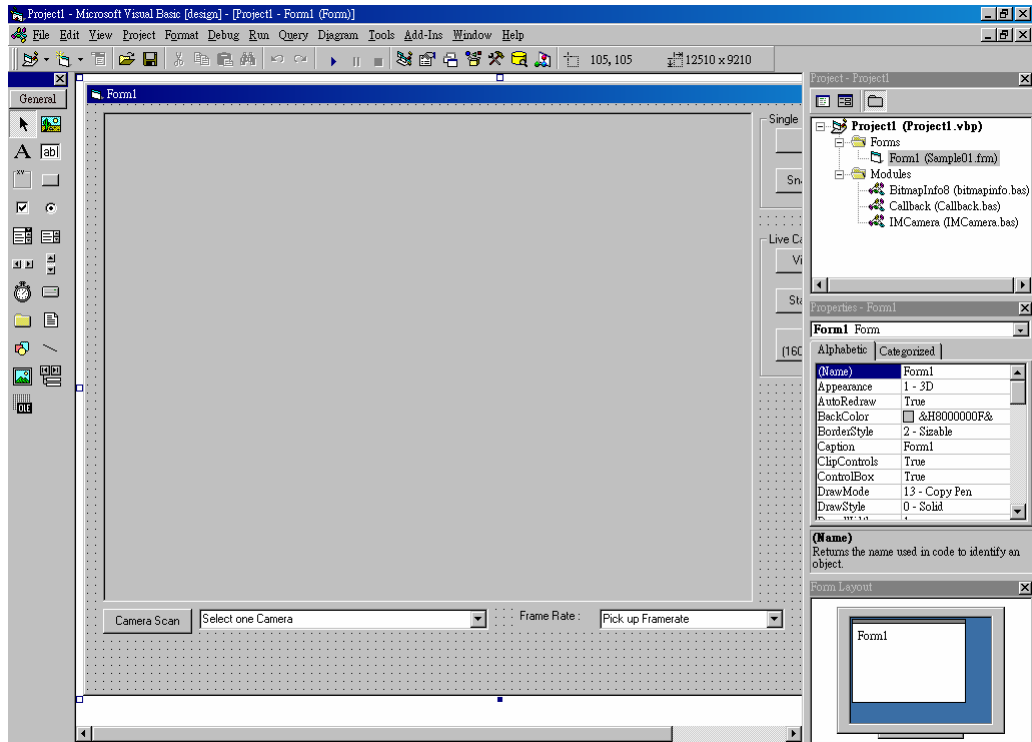

# 7 Mechanical

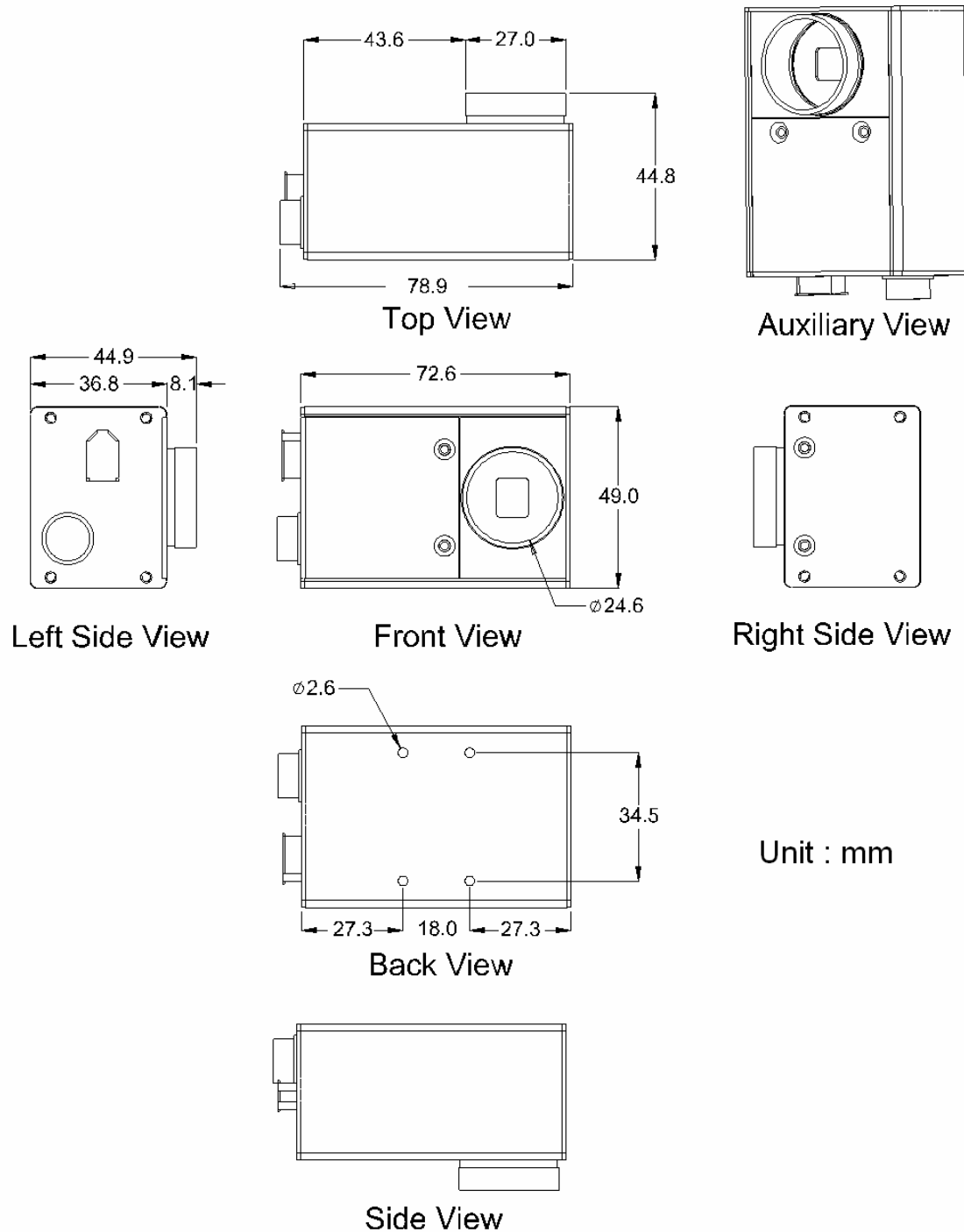

# 8 Appendix

## 8.1 Standards Compliance



**Report No. : FV6N2310**

### **For customers in the U.S.A.**

This equipment has been tested and found to comply with the limits for a Class A digital device, pursuant to Part 15 of the FCC Rules. These limits are designed to provide reasonable protection against harmful interference when the equipment is operated in a commercial environment. This equipment generates, uses, and can radiate radio frequency energy and, if not installed and used in accordance with the instruction manual, may cause harmful interference to radio communications. Operation of this equipment in a residential area is likely to cause harmful interference in which case the user will be required to correct the interference at his own expense. You are cautioned that any changes or modifications not expressly approved in this manual could void your authority to operate this equipment. The shielded interface cable recommended in this manual must be used with this equipment in order to comply with the limits for a computing device pursuant to Subpart J of Part 15 of FCC Rules.

### **For customers in Canada**

This apparatus complies with the Class A limits for radio noise emissions set out in the Radio Interference Regulations.

### **Pour utilisateurs au Canada**

Cet appareil est conforme aux normes classe A pour bruits radioélectriques, spécifiées dans le Règlement sur le brouillage radioélectrique.

### **Life support applications**

These products are not designed for use in life support appliances, devices, or systems where malfunction of these products can reasonably be expected to result in personal injury. Allied customers using or selling these products for use in such applications do so at their own risk and agree to fully indemnify Allied for any damages resulting from such improper use or sale.



**Certificated No. :EC6N2310**

The equipment was passed the test performed according to:

European Standard EN 55022:1998/A1:2000/A2:2003 Class A, EN 61000-3-2:2000, EN 61000-3-3:1995/A1:2001, EN 55024:1998/A1:2001/A2:2003(IEC 61000-4-2:1995/A2:2000, IEC 61000-4-3:2002, IEC 61000-4-4:1995/A2:2001, IEC 61000-4-5:1995/A1:2000, IEC 61000-4-6:1996/A1:2000, IEC 61000-4-8:1993/A1:2000, IEC 61000-4-11:1994/A1:2000)



## 8.2 Glossary

**AOI** means the area of interest. A user-defined, rectangular area (a square is common) on a CCD that is exposed and processed as an image. For image processing field, the AOI also means a user-defined area for inspection or measurement application for saving system images processing time.

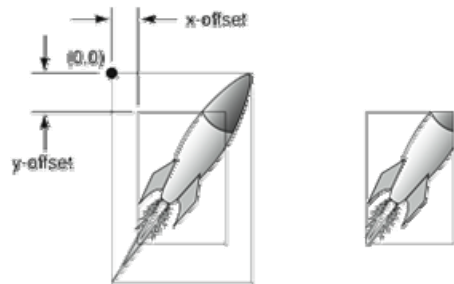

**Bit Depth** -The number of bits used to code a value (such as a pixel component) into an integer value. This is directly related to the number of levels that the value might have, such as 256 with an 8-bit depth or 1,024 with a 10-bit depth.

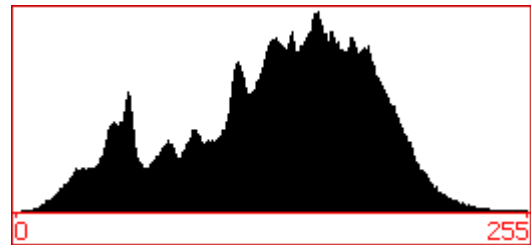

**CMOS (Complementary Metal-Oxide Semiconductor)** – CMOS is a widely used type of semiconductor. CMOS semiconductors use both NMOS (negative polarity) and PMOS (positive polarity) circuits. Since only one of the circuit types is on at any given time, CMOS chips require less power than chips using just one type of transistor. CMOS traditionally consumes little power and can be fabricated on just about any standard silicon production line, so they tend to be extremely inexpensive compared to CCD sensors.

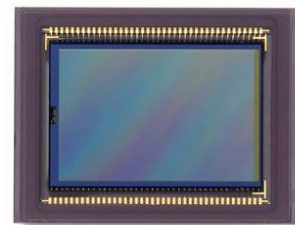

**FireWire/1394** - The 1394 digital link standard was conceived in 1986 by technologists at Apple Computer, who chose the trademark 'FireWire', in reference to its speeds of operation. In 1995, the IEEE

6-pin with power



IEEE 1394 Firewire

4-pin without power



iLink

(Institute of Electrical and Electronic Engineers) defined this standard is IEEE 1394. There are two IEEE 1394 standards in current market; 1394a for data transmission rates up to 400Mbps, and the other is IEEE 1394b; for data transmission rates up to 800Mbps.

**Gain** is the level of amplification of a signal. The Gain affects image sharpness sensed by the naked eye. When gain is increased in an image, one must also take into consideration the addition of significant "noise".

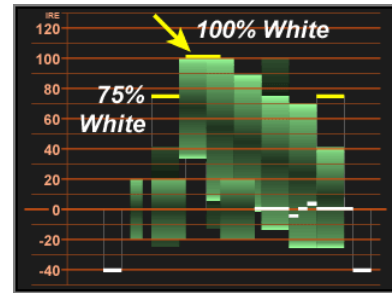

**Pixel Size** - Most CCD and CMOS imagers consist of picture elements dubbed "pixels". Each pixel is one sensor within the array and has a definite size, which should be available by the manufacturer. Sizes typically range from 8-20 microns. The pixel size is a technical parameter that relates to resolution, process feature dimensions and pixel architecture. For a given die size, a high resolution requires a small pixel

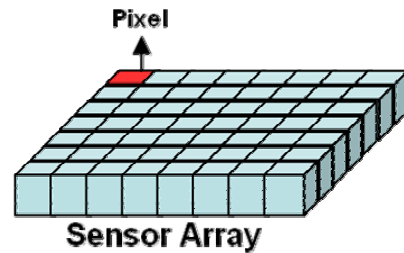

**Progressive-Scan** - A system of video scanning whereby lines of a picture are transmitted consecutively, such as in the computer world. This method is often used in DVD video encoding where the video is produced by scanning the film. It is also used in enhanced and high definition television systems as it is supposed to produce less visual artifacts than the interlaced mode but requires a higher refreshing rate.

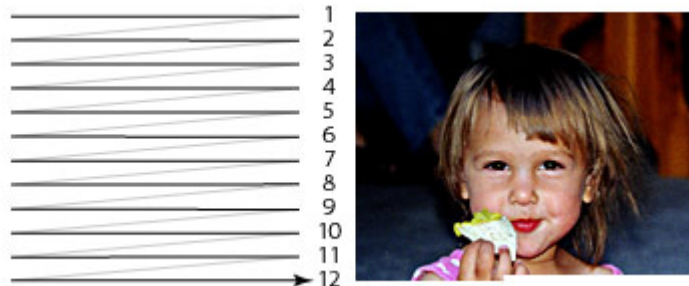

**Sensor Size** - The "Sensor Size" is the dimensions of CCD/CMOS sensor area, which is responsible for transforming light into electrical signals. Typically, the sensor size from 1/4" to 1" and measured by diagonal size.

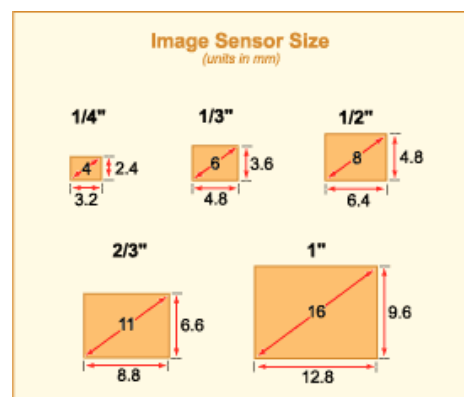

### 8.3 Revision History

Revision Date	Change Description
2006-12-14	Index bookmark build up, add BCB6 and C#.NET Syntax, add CE and FCC Certificated
2007-06-27	1. Add Programming Flowchart. 2. Modify Function Library 3. EZView Utility revision
2008-04-30	1. Add EzVIEW_Fly Utility 2. Modify input circuit sample 3. Modify Shutter value from value (0~4095) to time (20us ~ 81900us) 4. EZView Utility revision

# Warranty Policy

ICP DAS supplies a one year warranty period for the MAVIS IM-30/IM-100 IEEE 1394 camera series, however there certain instances of limited of warranty situations, whereby ICP DAS will not take any responsibility in the following cases:

1. When user open camera housing then warranty will void immediately.
2. In case damages or losses are caused by fire, earthquake, or other acts of the Gods, the act by third party, misuse by the user deliberately or erroneously, use under extreme operating conditions.
3. In case damages or losses are caused by malfunction resulting from bad connection with other equipment.
4. In case damages or losses are caused by incorrect use which is not in line with instruction in user's manual.
5. In case indirect, additional, consequential damages (loss of expected interest, suspension of business activities) are incurred as results of malfunction or non-function of the equipment, we shall be exempted from assuming responsibility for such damages.

# ICP DAS Worldwide

## **Headquarters**

### **ICP DAS CO., LTD.**

No.111, Kuangfu N. Rd., Hukou Shiang,  
Hsinchu Hsien, Taiwan 303, R.O.C

TEL: +886-3-597-3366

FAX: +886-3-597-3733

[service@icpdas.com](mailto:service@icpdas.com)

## **Taiwan Branch Office**

### **Ban-Ciao**

8F-2, No.33, Sec. 1, Minson Road, Banciao  
City, Taipei Hsien, Taiwan 220, R.O.C

TEL: +886-2-2950-0655

FAX:+886-2-2950-0807

[banciao@icpdas.com](mailto:banciao@icpdas.com)

### **Hsin-Tien**

7F-2, No. 137, Lane 235, Bao-Chiao R., Hsin-  
Tien City, Taipei Hsien, Taiwan 231, R.O.C

TEL : (02)8919-2216

FAX : (02)8919-2221

[hsintien@icpdas.com](mailto:hsintien@icpdas.com)

### **Tai-Chung**

9F-6, No.123, Sec. 3, Zhong-Gang Road,  
Tai-Chung City, Taiwan 407, R.O.C

TEL : (04)2358-2815

FAX : (04)2358-9114

[taichung@icpdas.com](mailto:taichung@icpdas.com)

### **Kao-Hsiung**

3F, No. 505, Zhong-Shan second Road,  
Kao-Hsiung City, Taiwan 801, R.O.C

TEL : (07)215-7688

FAX : (07)216-2602

[kaoshiung@icpdas.com](mailto:kaoshiung@icpdas.com)

## **USA Branch Office**

### **ICP DAS USA, Inc.**

2531 West 237th Street, Suite 121  
Torrance, CA 90505, USA

TEL: 1-310-517-9888

FAX: 1-310-517-0998

[Sales@icpdas-usa.com](mailto:Sales@icpdas-usa.com)

## **Europe Branch Office**

### **ICPDAS-EUROPE GmbH**

Humboldtstrasse 36  
70771 Leinfelden-Echterdingen

Germany

TEL: 0049-711-9 97 37 75

FAX: 0049-711-9 97 37 84

[info@icpdas-europe.com](mailto:info@icpdas-europe.com)

## **China Branch Office**

### **Beijing**

TEL : 86-10-6298-0924

FAX : 86-10-6296-2890

[beijing@icpdas.com.cn](mailto:beijing@icpdas.com.cn)

### **Shanghai**

TEL : 86-21-6247-1722

FAX : 86-21-6247-1725

[shanghai@icpdas.com.cn](mailto:shanghai@icpdas.com.cn)

### **Wuhan**

TEL : 86-27-8548-3302

### **Kunming**

TEL : 86-13113689519

86-87-1294-5396

## Free Manuals Download Website

<http://myh66.com>

<http://usermanuals.us>

<http://www.somanuals.com>

<http://www.4manuals.cc>

<http://www.manual-lib.com>

<http://www.404manual.com>

<http://www.luxmanual.com>

<http://aubethermostatmanual.com>

Golf course search by state

<http://golfingnear.com>

Email search by domain

<http://emailbydomain.com>

Auto manuals search

<http://auto.somanuals.com>

TV manuals search

<http://tv.somanuals.com>