

## Limited 90-Day Warranty

iHome Products, a division of SDI Technologies Inc. (hereafter referred to as SDI Technologies), warrants this product to be free from defects in workmanship and materials, under normal use and conditions, for a period of 90 days from the date of original purchase.

Should this product fail to function in a satisfactory manner, it is best to first return it to the store where it was originally purchased. Should this fail to resolve the matter and service still be required by reason of any defect or malfunction during the warranty period, SDI Technologies will repair or, at its discretion, replace this product without charge (except for a \$7.00 charge for handling, packing, return UPS/postage, and insurance). This decision is subject to verification of the defect or malfunction upon delivery of this product to the Factory Service Center listed below. The product must include proof of purchase, including date of purchase. The fee for service without proof of purchase is \$15.00.

Before returning this product for service, please first replace the batteries (if applicable) with fresh ones, as exhausted or defective batteries are the most common cause of problems encountered.

If service is still required:

1. Remove the batteries (if applicable) and pack the unit in a well padded, heavy corrugated box.
2. Enclose a photocopy of your sales receipt, credit card statement, or other proof of the date of purchase, if within the warranty period.
3. Enclose a check or money order payable to the order of SDI Technologies, for the sum of \$7.00 (\$15.00 without proof of purchase).
4. Send the unit prepaid and insured, to the Factory Service Center listed below.

**Consumer Repair Department**  
SDI Technologies Inc.  
1330 Goodyear Drive  
El Paso, TX 79936-6420

### Disclaimer of Warranty

NOTE: This warranty is valid only if the product is used for the purpose for which it was designed. It does not cover (i) products which have been damaged by negligence or willful actions, misuse or accident, or which have been modified or repaired by unauthorized persons; (ii) cracked or broken cabinets, or units damaged by excessive heat; (iii) damage to digital media players, CD's or tape cassettes (if applicable); (iv) the cost of shipping this product to the Factory Service Center and its return to the owner.

This warranty is valid only in the United States of America and does not extend to owners of the product other than to the original purchaser. In no event will SDI Technologies or any of its affiliates, contractors, resellers, their officers, directors, shareholders, members or agents be liable to you or any third party for any consequential or incidental damages, any lost profits, actual, exemplary or punitive damages. (Some states do not allow limitations on implied warranties or exclusion of consequential damages, so these restrictions may not apply to you.) This warranty gives you specific legal rights, and you may also have other rights which vary from state to state.

Your acknowledgement and agreement to fully and completely abide by the above mentioned disclaimer of warranty is contractually binding to you upon your transfer of currency (money order, cashier's check, or credit card) for purchase of your SDI Technologies product.

Questions? Visit [www.ihomeaudio.com](http://www.ihomeaudio.com)  
For any other questions: 1-800-288-2792 Toll Free  
©2006 SDI Technologies, Inc. All Rights Reserved.

SRS® is a registered trademark of SRS Labs, Inc.  
TruBass technology is incorporated under  
license from SRS Labs, Inc.

# iHome2GO™

Model iHM1  
**the speaker system  
for your iPod nano**

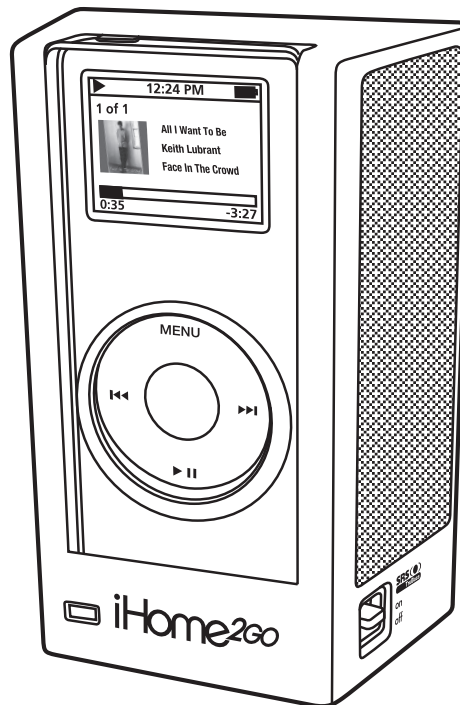

### IMPORTANT Read before proceeding

If you have any questions regarding the operation or use of this product, please visit [www.ihomeaudio.com](http://www.ihomeaudio.com) to view answers to frequently asked questions.

To learn more about this and other iHome products, please visit us online at [www.ihomeaudio.com](http://www.ihomeaudio.com)

## Using the iHM1

Thank you for purchasing the iHM1, the speaker system for your iPod nano. Designed specifically to work with your iPod nano, this system provides high quality audio and that invites your music to come out and play. Please read the instructions carefully before operating the unit and keep for future reference.

### Installing/Replacing Batteries

1. Open the battery compartment cover located on the back of the unit.
2. Insert 3 "AA" (LR6) batteries, checking that the + and - ends of the batteries match the drawing inside the battery compartment. We recommend the use of alkaline batteries for longer life.
3. Close the compartment cover.

### Battery information:

- Do not mix old and new batteries.
- Do not mix alkaline, standard (carbon-zinc) or rechargeable batteries.
- Make sure you dispose of batteries properly (see your local regulations).

### iPod nano switch (located on bottom of unit):

- Default setting is for the new 2g iPod nano.
- If you have an original 1g iPod nano, slide the switch to the left position.

### Inserting/Removing iPod nano from the unit

1. Slide your iPod nano into the unit as shown. Please make sure the iPod nano is fully docked into the unit before turning on power on the unit.
2. To remove your iPod nano, push the "Release" button down. The iPod nano will pop up and you can tilt it into the palm of your hand.

### Listening to your iHM1

1. Turn on your iPod nano and set desired volume.
2. Switch the mode button located on the right side of the unit to On or to SRS TruBass if you want more bass.
3. Because audio tracks are mastered differently, you may notice discrepancies in volume from song to song. For best sound, turn Sound Check ON in your nano's Settings menu.
4. Remember to turn unit OFF when not in use to save batteries. To extend battery life, play unit without SRS TruBass feature.

## Maintenance

- Place the unit away from sources of direct sunlight or excessive heat.
- Protect your furniture when placing your unit on a natural wood and lacquered finish.
- Clean your unit with a soft cloth moistened only with mild soap and water. Stronger cleaning agents, such as thinner or similar materials can mar the surface of the case.

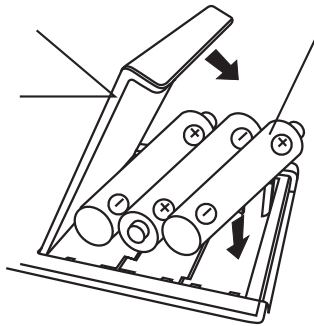

Battery Installation

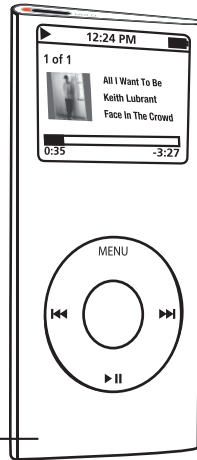

New 2g iPod nano

**NOTE:**  
FOR BEST SOUND,  
turn Sound Check ON  
in your iPod Settings  
menu

**NOTE:** ADJUST iPod  
VOLUME TO AVOID  
DISTORTION

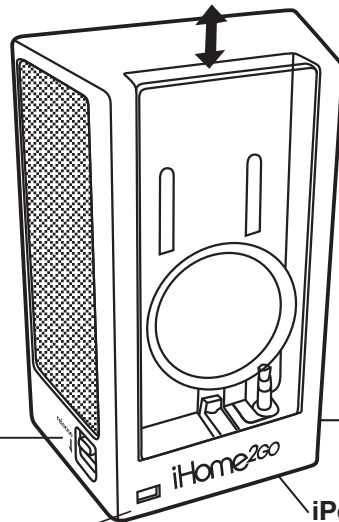

Release Button

Mode Button

iPod nano switch

Power Indicator



1g(original)

2g(new)

**NOTE:** UNIT DOES NOT CHARGE iPod nano

## Free Manuals Download Website

<http://myh66.com>

<http://usermanuals.us>

<http://www.somanuals.com>

<http://www.4manuals.cc>

<http://www.manual-lib.com>

<http://www.404manual.com>

<http://www.luxmanual.com>

<http://aubethermostatmanual.com>

Golf course search by state

<http://golfingnear.com>

Email search by domain

<http://emailbydomain.com>

Auto manuals search

<http://auto.somanuals.com>

TV manuals search

<http://tv.somanuals.com>